

PRODUCT NUMBER

SEE TABLE

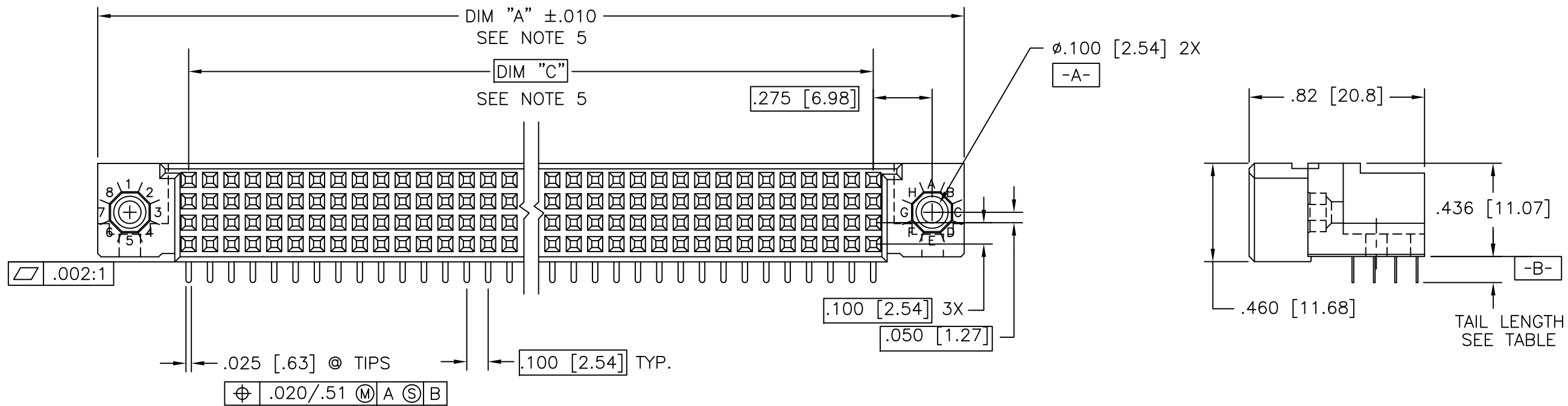
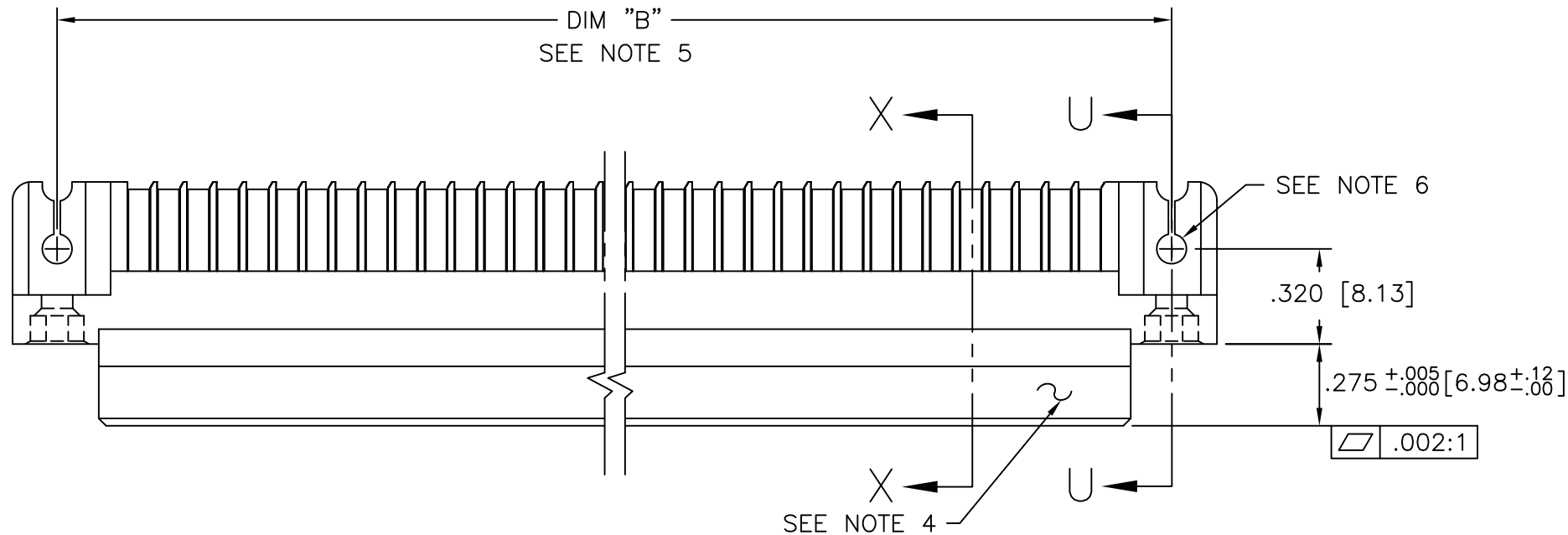

mat'l. code		surface		tolerance		projection		product family	
NOTE 3		ISO 1302 ✓		ISO 406 ISO 1101		INCH/MM		HPC	
ltr	ecn no	dr	date	tolerances unless otherwise specified		scale 1:1		title	
T	ELX-I-26895	MJA	05/03/17	angles	linear			4 ROW R/A RECEPTACLE SOLDER TAIL, 0 GUIDE PIN	
-	-	-	-	0°±2'				dwg no	
M	V05-0207	VS	3/2/05					sheet 1 of 5	
N	V05-1052	HTB	12/7/05	dr	G.PETERS	6/4/96		size	
P	M06-0283	MHT	7/27/06	enr	S.CLARK	6/3/96		A3	
R	M07-0099	AGS	2/09/07	chr	M JACOB	05/03/17		50295	
S	M08-0280	AGS	9/30/08	appd	BIJU K PAUL	05/03/17		type	
sheet		revision		T	T	T	S	Product Customer Drawing	
index		sheet		1	2	3	4	5	

PRODUCT NUMBER  
SEE TABLE

NOTES:

- ① PRODUCT NUMBERING CODE:  
50295 - X YYY Z S LF  
LEAD FREE (OPTIONAL)  
SPECIAL FEATURES (NOTE 6)  
TAIL LENGTH (SEE TABLE)  
NO. OF POSITIONS (NOTE 2)  
PLATING (SEE TABLE)  
BASE NUMBER
- ② THIS PRODUCT IS CONFIGURED IN SIZES OF 6 thru 80 COLUMNS IN INCREMENTS OF ONE.  
i.e.: 6,7,8,9.....79,80.
- ③ HOUSING MATERIAL: GLASS & MINERAL FILLED HIGH-TEMP THERMOPLASTIC, FLAME RETARDANT PER UL94 V-0.  
CONTACT MATERIAL: BeCu
- ④ MANUFACTURE'S NAME, PART NUMBER AND LOT CODE TO APPEAR ON THIS SURFACE PER BUS-12-108.
- ⑤ LENGTH DIMENSION FORMULAS:  
DIM "A" =  $.100/2.54 \times \text{NO. OF COLUMNS} + .75/19.1$   
DIM "B" =  $.100/2.54 \times \text{NO. OF COLUMNS} + .450/11.43$   
DIM "C" =  $.100/2.54 \times \text{NO. OF COLUMNS} - .100/2.54$
- ⑥ SPECIAL FEATURES (SEE SHEET 3) AND TABLE.  
- = IF CODE IS OMITTED FROM PRODUCT NUMBER: CONNECTOR IS PROVIDED AS SHOWN, NO SPECIAL FEATURES ARE SELECTED. FOR P.C.B. ATTACHEMENT IN A  $\phi.120[3.05]$  MOUNTING HOLE.  
"A" = IF SPECIFIED, PRE-INSTALLED CLAW FOR P.C.B. ATTACHEMENT IN A  $\phi.100[2.54]$  MOUNTING HOLE. AVAILABLE IN 'E' TAIL LENGTH ONLY.  
"B" = IF SPECIFIED, PRE-INSTALLED CLAW FOR P.C.B. ATTACHEMENT IN A  $\phi.120[3.05]$  MOUNTING HOLE.  
"C" = IF SPECIFIED, MOLDED GUIDE PINS WITH PRE-INSTALLED CLAW FOR P.C.B. ATTACHEMENT IN A  $\phi.120[3.05]$  MOUNTING HOLE.  
"D" = IF SPECIFIED, MOLDED GUIDE PINS WITH  $\phi.100[2.54]$  MOUNTING HOLE (NO CLAW).
- ⑦ CLAW DIMENSION DETERMINED BY P.C.B. HOLE DIAMETER.
8. THIS PRODUCT (WITH "LF" SUFFIX) MEETS EUROPEAN UNION DIRECTIVES AND OTHER COUNTRY REGULATIONS AS DESCRIBED IN GS-22-008.
9. THIS HOUSING WILL WITHSTAND EXPOSURE TO 260 DEGREES C PEAK TEMPERATURE FOR 10-30 SECONDS IN A CONVECTION, INFRA-RED OR VAPOR PHASE REFLOW OVEN.
- ⑩ PLATING OPTION:  
MAY BE EITHER GOLD OR GXT PLATED AT MANUFACTURER'S OPTION.

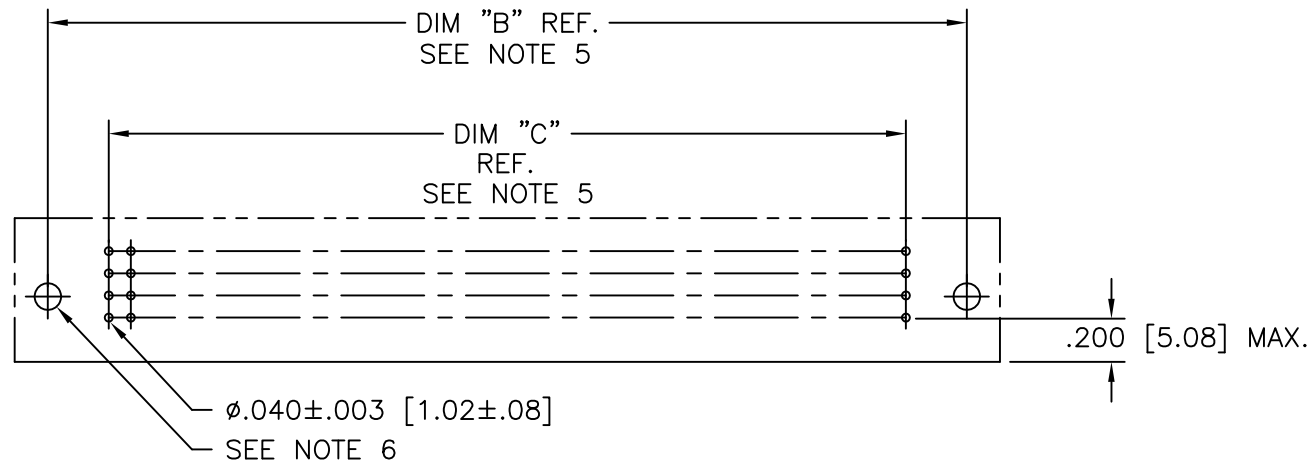
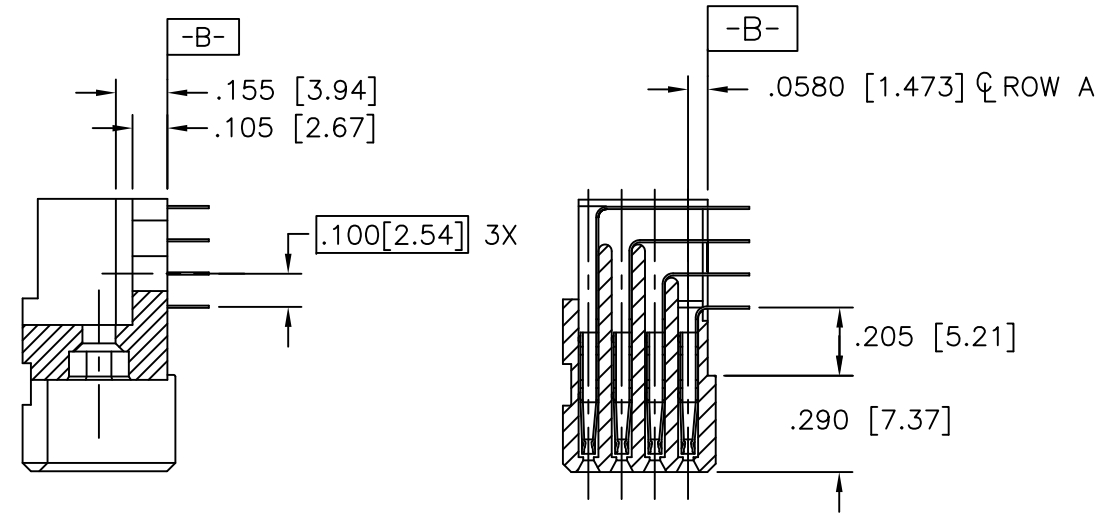

RECOMMENDED PCB LAYOUT  
(ALL HOLES LOCATED ON  $.100 [2.54]$  GRID UNLESS OTHERWISE SPECIFIED)

mat'l. code NOTE 3		surface ISO 1302 <input checked="" type="checkbox"/>	tolerance ISO 406 ISO 1101	projection 	product family HPC
ltr	ecn no	dr	date	tolerances unless otherwise specified	title 4 ROW R/A RECEPTACLE SOLDER TAIL, 0 GUIDE PIN
T				angles linear $.XX \pm .01 / .X \pm 0.3$ $.XXX \pm .005 / .XX \pm 0.13$ $.XXXX \pm .0020 / .XXX \pm 0.051$	
				$0^\circ \pm 2^\circ$	
		dr	G.PETERS	6/4/96	Amphenol FCi dwg no 50295 sheet 2 of 5 size A3 type Product Customer Drawing
		enr	S.CLARK	6/3/96	
		chr	M JACOB	05/03/17	
		appd	BIJU K PAUL	05/03/17	
sheet index	revision sheet				

PRODUCT NUMBER

SEE TABLE

SPECIAL FEATURE OPTION A

SPECIAL FEATURE OPTION B

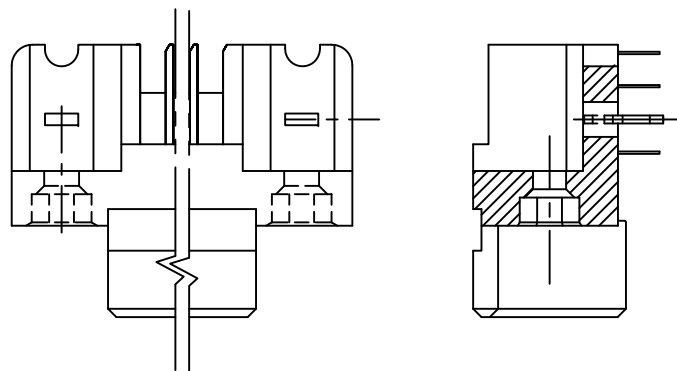

SECTION U-U

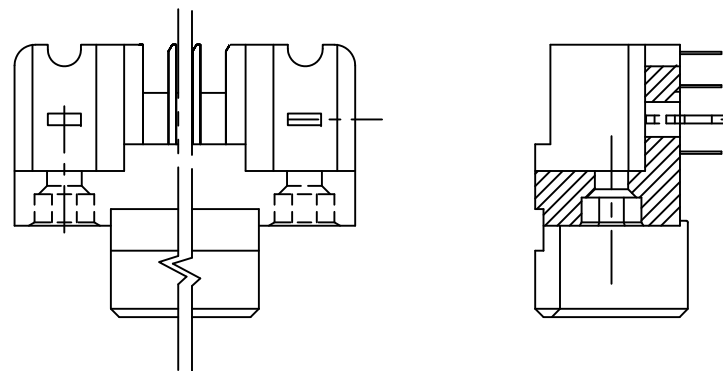

SECTION U-U

SPECIAL FEATURE OPTION C

SPECIAL FEATURE OPTION D

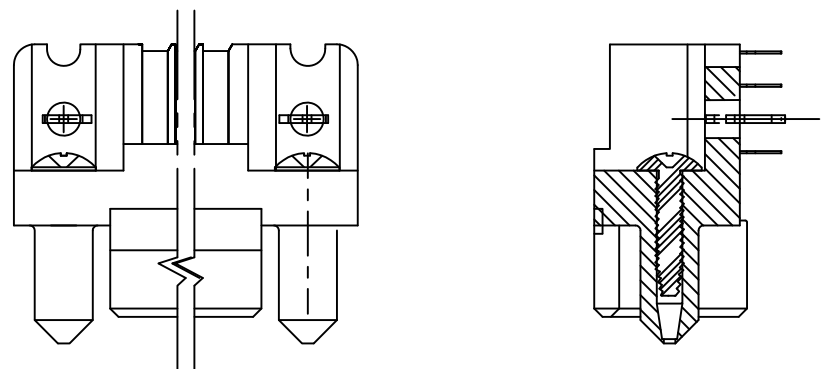

SECTION U-U

SELF TAPPING SCREW (2x)

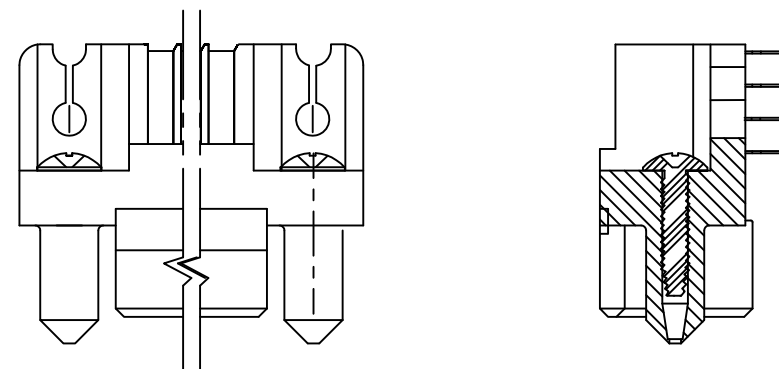

SECTION U-U

SELF TAPPING SCREW (2x)

NOTE 7

Amphenol  
FCi

Copyright AFci

mat'l. code NOTE 3		surface ISO 1302 ✓	tolerance ISO 406 ISO 1101	projection 	product family HPC
ltr	ecn no	dr	date	tolerances unless otherwise specified	title 4 ROW R/A RECEPTACLE SOLDER TAIL, 0 GUIDE PIN
T				angles 0°±2°	
				linear .XX±.01/.X±0.3 .XXX±.005/.XX±0.13 .XXX±.0020/.XXX±0.051	
sheet index		revision sheet		dr G.PETERS 6/4/96	dwg no 50295
				enr S.CLARK 6/3/96	sheet 3 of 5 size A3
				chr M JACOB 05/03/17	type Product Customer Drawing
				appd BIJU K PAUL 05/03/17	

PRODUCT NUMBER NOTE 1 AND 2	NUMBER OF POSITIONS SEE NOTE 2	TAIL LENGTH ±.010/0.25	SPECIAL FEATURES SEE NOTE 6	TAIL PLATING	CONTACT PLATING SEE NOTE 10	PRODUCT NUMBER NOTE 1 AND 2	NUMBER OF POSITIONS SEE NOTE 2	TAIL LENGTH ±.010/0.25	SPECIAL FEATURES SEE NOTE 6	TAIL PLATING	CONTACT PLATING SEE NOTE 10
50295-1YYYE	YYY	.125/3.18	NONE	TIN-LEAD	30μ"/0.76μ Au	50295-1YYYELF	YYY	.125/3.18	NONE	TIN	30μ"/0.76μ Au
50295-1YYYEA	YYY	.125/3.18	"A"		30μ"/0.76μ Au	50295-1YYYEALF	YYY	.125/3.18	"A"		30μ"/0.76μ Au
50295-1YYYEB	YYY	.125/3.18	"B"		30μ"/0.76μ Au	50295-1YYYEBLF	YYY	.125/3.18	"B"		30μ"/0.76μ Au
50295-1YYYEC	YYY	.125/3.18	"C"		30μ"/0.76μ Au	50295-1YYYECLF	YYY	.125/3.18	"C"		30μ"/0.76μ Au
50295-1YYYED	YYY	.125/3.18	"D"		30μ"/0.76μ Au	50295-1YYYEDLF	YYY	.125/3.18	"D"		30μ"/0.76μ Au
50295-1YYYF	YYY	.145/3.68	NONE		30μ"/0.76μ Au	50295-1YYYFLF	YYY	.145/3.68	NONE		30μ"/0.76μ Au
50295-1YYYFB	YYY	.145/3.68	"B"		30μ"/0.76μ Au	50295-1YYYFBLF	YYY	.145/3.68	"B"		30μ"/0.76μ Au
50295-1YYYFC	YYY	.145/3.68	"C"		30μ"/0.76μ Au	50295-1YYYFCLF	YYY	.145/3.68	"C"		30μ"/0.76μ Au
50295-1YYYFD	YYY	.145/3.68	"D"		30μ"/0.76μ Au	50295-1YYYFDLF	YYY	.145/3.68	"D"		30μ"/0.76μ Au
50295-1YYYH	YYY	.180/4.57	NONE		30μ"/0.76μ Au	50295-1YYYHLF	YYY	.180/4.57	NONE		30μ"/0.76μ Au
50295-1YYYHB	YYY	.180/4.57	"B"		30μ"/0.76μ Au	50295-1YYYHBLF	YYY	.180/4.57	"B"		30μ"/0.76μ Au
50295-1YYYHC	YYY	.180/4.57	"C"		30μ"/0.76μ Au	50295-1YYYHCLF	YYY	.180/4.57	"C"		30μ"/0.76μ Au
50295-1YYYHD	YYY	.180/4.57	"D"		30μ"/0.76μ Au	50295-1YYYHDLF	YYY	.180/4.57	"D"		30μ"/0.76μ Au
50295-3YYYE	YYY	.125/3.18	NONE		50μ"/1.27μ Au	50295-3YYYELF	YYY	.125/3.18	NONE		50μ"/1.27μ Au
50295-3YYYEA	YYY	.125/3.18	"A"		50μ"/1.27μ Au	50295-3YYYEALF	YYY	.125/3.18	"A"		50μ"/1.27μ Au
50295-3YYYEB	YYY	.125/3.18	"B"		50μ"/1.27μ Au	50295-3YYYEBLF	YYY	.125/3.18	"B"		50μ"/1.27μ Au
50295-3YYYEC	YYY	.125/3.18	"C"		50μ"/1.27μ Au	50295-3YYYECLF	YYY	.125/3.18	"C"		50μ"/1.27μ Au
50295-3YYYED	YYY	.125/3.18	"D"		50μ"/1.27μ Au	50295-3YYYEDLF	YYY	.125/3.18	"D"		50μ"/1.27μ Au
50295-3YYYF	YYY	.145/3.68	NONE		50μ"/1.27μ Au	50295-3YYYFLF	YYY	.145/3.68	NONE		50μ"/1.27μ Au
50295-3YYYFB	YYY	.145/3.68	"B"		50μ"/1.27μ Au	50295-3YYYFBLF	YYY	.145/3.68	"B"		50μ"/1.27μ Au
50295-3YYYFC	YYY	.145/3.68	"C"		50μ"/1.27μ Au	50295-3YYYFCLF	YYY	.145/3.68	"C"		50μ"/1.27μ Au
50295-3YYYFD	YYY	.145/3.68	"D"		50μ"/1.27μ Au	50295-3YYYFDLF	YYY	.145/3.68	"D"		50μ"/1.27μ Au
50295-3YYYH	YYY	.180/4.57	NONE		50μ"/1.27μ Au	50295-3YYYHLF	YYY	.180/4.57	NONE		50μ"/1.27μ Au
50295-3YYYHB	YYY	.180/4.57	"B"		50μ"/1.27μ Au	50295-3YYYHBLF	YYY	.180/4.57	"B"		50μ"/1.27μ Au
50295-3YYYHC	YYY	.180/4.57	"C"		50μ"/1.27μ Au	50295-3YYYHCLF	YYY	.180/4.57	"C"		50μ"/1.27μ Au
50295-3YYYHD	YYY	.180/4.57	"D"	TIN-LEAD	50μ"/1.27μ Au	50295-3YYYHDLF	YYY	.180/4.57	"D"	TIN	50μ"/1.27μ Au

TABLE CONTINUED ON SHEET 5

Amphenol  
FCi

Copyright AFci

mat'l. code NOTE 3		surface ISO 1302 ✓	tolerance ISO 406 ISO 1101	projection 	product family HPC
ltr	ecn no	dr	date	tolerances unless otherwise specified	title 4 ROW R/A RECEPTACLE SOLDER TAIL, 0 GUIDE PIN
S				linear XX±.01/.X±0.3 XXX±.005/.XX±0.13 XXXX±.0020/.XXX±0.051	
				angles 0°±2°	
				dr G.PETERS 6/4/96	dwg no sheet 4 of 5 size
				enr S.CLARK 6/3/96	50295 A3
				chr S.CLARK 6/4/96	type Product Customer Drawing
				appd S.CLARK 6/4/96	
sheet index	revision sheet				

PRODUCT NUMBER NOTE 1 AND 2	NUMBER OF POSITIONS SEE NOTE 2	TAIL LENGTH ±.010/0.25	SPECIAL FEATURES SEE NOTE 6	TAIL PLATING	CONTACT PLATING SEE NOTE 10
50295-5YYYE	YYY	.125/3.18	NONE	TIN/LEAD	30μ"/0.76μ GXT
50295-5YYYELF	YYY	.125/3.18	NONE	TIN	
50295-5YYYEA	YYY	.125/3.18	"A"	TIN/LEAD	
50295-5YYYEALF	YYY	.125/3.18	"A"	TIN	
50295-5YYYEB	YYY	.125/3.18	"B"	TIN/LEAD	
50295-5YYYEBLF	YYY	.125/3.18	"B"	TIN	
50295-5YYYEC	YYY	.125/3.18	"C"	TIN/LEAD	
50295-5YYYECLF	YYY	.125/3.18	"C"	TIN	
50295-5YYYED	YYY	.125/3.18	"D"	TIN/LEAD	
50295-5YYYEDLF	YYY	.125/3.18	"D"	TIN	
50295-5YYYF	YYY	.145/3.68	NONE	TIN/LEAD	
50295-5YYYFLF	YYY	.145/3.68	NONE	TIN	
50295-5YYYFB	YYY	.145/3.68	"B"	TIN/LEAD	
50295-5YYYFBLF	YYY	.145/3.68	"B"	TIN	
50295-5YYYFC	YYY	.145/3.68	"C"	TIN/LEAD	
50295-5YYYFCLF	YYY	.145/3.68	"C"	TIN	
50295-5YYYFD	YYY	.145/3.68	"D"	TIN/LEAD	
50295-5YYYFDLF	YYY	.145/3.68	"D"	TIN	
50295-5YYYH	YYY	.180/4.57	NONE	TIN/LEAD	
50295-5YYYHLF	YYY	.180/4.57	NONE	TIN	
50295-5YYYHB	YYY	.180/4.57	"B"	TIN/LEAD	
50295-5YYYHBLF	YYY	.180/4.57	"B"	TIN	
50295-5YYYHC	YYY	.180/4.57	"C"	TIN/LEAD	
50295-5YYYHCLF	YYY	.180/4.57	"C"	TIN	
50295-5YYYHD	YYY	.180/4.57	"D"	TIN/LEAD	
50295-5YYYHDLF	YYY	.180/4.57	"D"	TIN	30μ"/0.76μ GXT

Amphenol  
FCI

Copyright AFCl

mat'l. code NOTE 3		surface ISO 1302 ✓	tolerance ISO 406 ISO 1101	projection 	product family HPC
ltr	ecn no	dr	date	tolerances unless otherwise specified	title 4 ROW R/A RECEPTACLE SOLDER TAIL, 0 GUIDE PIN
S				linear .XX±.01/.X±0.3 .XXX±.005/.XX±0.13 .XXX±.0020/.XXX±0.051	
				angles 0°±2°	
		dr	G.PETERS	6/4/96	dwg no
		enr	S.CLARK	6/3/96	sheet 5 of 5
		chr	S.CLARK	6/4/96	size A3
		appd	S.CLARK	6/4/96	type Product Customer Drawing
sheet index	revision sheet				



Компания «ЭлектроПласт» предлагает заключение долгосрочных отношений при поставках импортных электронных компонентов на взаимовыгодных условиях!

Наши преимущества:

- Оперативные поставки широкого спектра электронных компонентов отечественного и импортного производства напрямую от производителей и с крупнейших мировых складов;
- Поставка более 17-ти миллионов наименований электронных компонентов;
- Поставка сложных, дефицитных, либо снятых с производства позиций;
- Оперативные сроки поставки под заказ (от 5 рабочих дней);
- Экспресс доставка в любую точку России;
- Техническая поддержка проекта, помощь в подборе аналогов, поставка прототипов;
- Система менеджмента качества сертифицирована по Международному стандарту ISO 9001;
- Лицензия ФСБ на осуществление работ с использованием сведений, составляющих государственную тайну;
- Поставка специализированных компонентов (Xilinx, Altera, Analog Devices, Intersil, Interpoint, Microsemi, Aeroflex, Peregrine, Syfer, Eurofarad, Texas Instrument, Miteq, Cobham, E2V, MA-COM, Hittite, Mini-Circuits, General Dynamics и др.);

Помимо этого, одним из направлений компании «ЭлектроПласт» является направление «Источники питания». Мы предлагаем Вам помощь Конструкторского отдела:

- Подбор оптимального решения, техническое обоснование при выборе компонента;
- Подбор аналогов;
- Консультации по применению компонента;
- Поставка образцов и прототипов;
- Техническая поддержка проекта;
- Защита от снятия компонента с производства.



#### Как с нами связаться

**Телефон:** 8 (812) 309 58 32 (многоканальный)

**Факс:** 8 (812) 320-02-42

**Электронная почта:** [org@eplast1.ru](mailto:org@eplast1.ru)

**Адрес:** 198099, г. Санкт-Петербург, ул. Калинина, дом 2, корпус 4, литера А.