

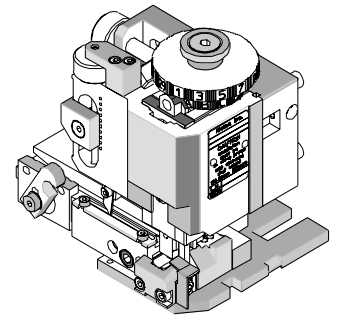

FineAdjust Applicator Specification Sheet Part No. 63900-1800



FEATURES

- Directly adapts to most automatic wire processing machines
- Quick punch removal with the push of a button for fast and easy tooling change
- Applicator designed to industry standard mounting and shut height 135.80mm (5.346")
- Quick set-up time; plus the crimp height, track and feed adjustments can be set without removing the applicator from the press
- Fine adjustment allows users to achieve target with little effort by adjusting in increments of .015mm (.0006") for conductor crimp height and .063mm (.0025") for insulation height
- Independent adjustment rings allow users to quickly adjust the conductor or insulation crimp height without affecting each other

SCOPE

Products: 1.78mm (.070") Tab Female Crimp Terminals, 14-20 AWG.

Terminal Series No.	Terminal Order No.	Wire Size		Insulation Diameter		Strip Length	
		AWG	mm ²	mm	In.	mm	In.
35028	35028-1111	14-20	2.00-0.50	1.60-3.65	.063-.144	4.20-5.00	.165-.197
This Applicator provides optimum A-620 Class 2 crimps with insulation O.D. range of 2.55-3.65 mm.							

DEFINITION OF TERMS

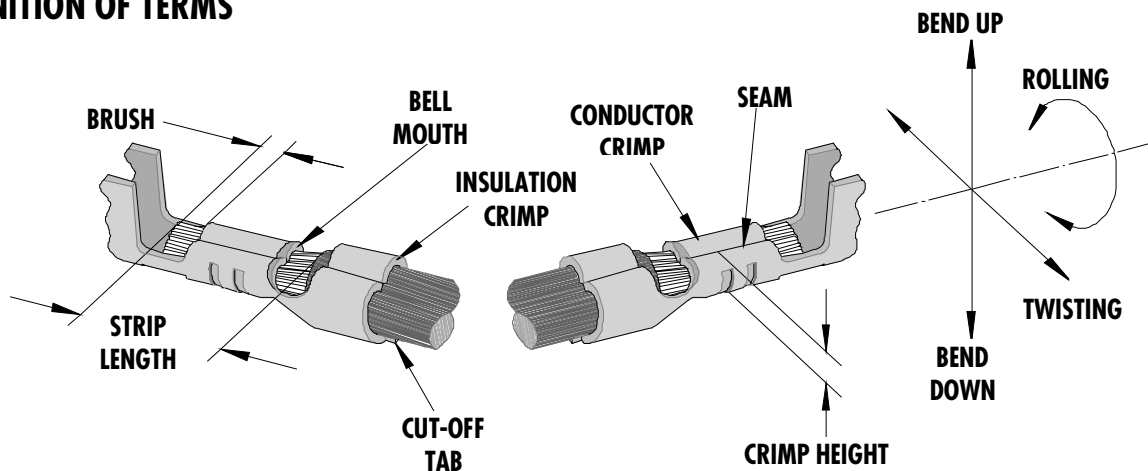

The above terminal drawing is a generic terminal representation. It is not an image of a terminal listed in the scope.

CRIMP SPECIFICATION

Terminal Series No.	Bell mouth		Cut-off Tab Maximum		Conductor Brush	
	Mm	In.	mm	In.	mm	In.
35028	0.20-0.50	.008-.020	0.20	.008	0.00-1.00	0.00-.039

Terminal Series No.	Bend up	Bend down	Twist	Roll	Punch Width mm (Ref)				Seam Seam shall not be open and no wire allowed out of the crimping area
	Degree		Degree		Conductor		Insulation		
	mm	In	mm	In	mm	In	mm	In	
35028	3	3	3	5	2.40	.094	3.40	.134	

After crimping, the conductor profile should measure the following.

Terminal Series No.	Wire Size		Conductor			
			Crimp Height		Crimp Width (Ref)	
	AWG	mm ²	mm	In.	mm	In.
35028	14	2.00	1.47-1.56	.058-.061	2.40-2.55	.094-.100
	16	1.30	1.40-1.48	.055-.058	2.40-2.55	.094-.100
	18	0.80	1.33-1.40	.052-.055	2.40-2.55	.094-.100
	20	0.50	1.25-1.32	.049-.051	2.40-2.55	.094-.100

Terminal Series No.	Wire Size		Insulation (Ref)				Pull Force Minimum	
			Crimp Height Max.		Crimp Width			
	AWG	mm ²	mm	In.	mm	In.	N	Lb.
35028	14	2.00	4.10	.161	3.50-3.70	.138-.146	146.6	33.0
	16	1.30	3.85	.152	3.50-3.70	.138-.146	127.1	28.6
	18	0.80	3.70	.146	3.50-3.70	.138-.146	107.5	24.2
	20	0.50	3.65	.144	3.50-3.70	.138-.146	58.6	13.2

Pull Force should be measured with no influence from the insulation crimp.

The above specifications are guidelines to an optimum crimp.

PARTS LIST

FineAdjust Applicator 63900-1800				
Item	Order No	Engineering No.	Description	Quantity
Perishable Tooling				
	63900-1870	63900-1870	Tool Kit (All "Y" Items)	REF
1	63444-2425	63444-2425	Conductor Punch	1 Y
2	63445-2443	63445-2443	Conductor Anvil	1 Y
3	63446-3410	63446-3410	Insulation Punch	1 Y
4	63445-3423	63445-3423	Insulation Anvil	1 Y
5	63443-0035	63443-0035	Front Cut-Off Plunger	1 Y
6	63443-0036	63443-0036	Front Plunger Retainer	1 Y
Other Components(REF 001850)				
7	11-17-0022	1739-21	Hold Down Spring	1
8	11-18-4083	60707-8	Feed Guide	1
9	11-24-1149	4996-37	Shank	1
10	63443-0009	63443-0009	Front Scrap Chute	1
11	63443-0024	63443-0024	Key	1
12	63443-0090	63443-0090	Wire Stop	1
13	63443-1719	63443-1719	18.9mm Height Spacer	1
14	63443-2214	63443-2214	14.0mm Coarse Spacer	1
15	63443-2317	63443-2317	3.85mm Fine Spacer	1
16	63443-2801	63443-2801	Front Plunger Striker	1
17	63443-2911	63443-2911	Wire Hold Down Plunger	1
18	63443-6122	63443-6122	Rear Cover	1
19	63443-7003	63443-7003	Terminal Hold Down	1
20	63600-0021	63600-0021	Wire Hold Down Spring	1
21	63700-0539	63700-0539	Cut-Off Plunger Spring	1
Frame				
22	63800-4901	63800-4901	Top	1
23	63801-3281	63801-3281	Base	1
24	63801-4650	63801-4650	Track	1
Hardware				
25	N/A	N/A	M3 by 6 Long SHCS	2**
26	N/A	N/A	M3 by 6 Long FHCS	1**
27	N/A	N/A	M4 by 6 Long SHCS	2**
28	N/A	N/A	M4 by 12 Long BHCS	2**
29	N/A	N/A	M4 by 50 Long SHCS	2**
30	N/A	N/A	M5 by 12 Lg SHCS	1**
31	N/A	N/A	#5-40 by 3/8" Long SHCS	1**
32	N/A	N/A	#10-32 by 3/8" Long Flat Point SSS	1**
33	N/A	N/A	#10-32 Hex Jam Nut	1**
** Available from an industrial supply company such as MSC (1-800-645-7270).				

Assembly Drawing

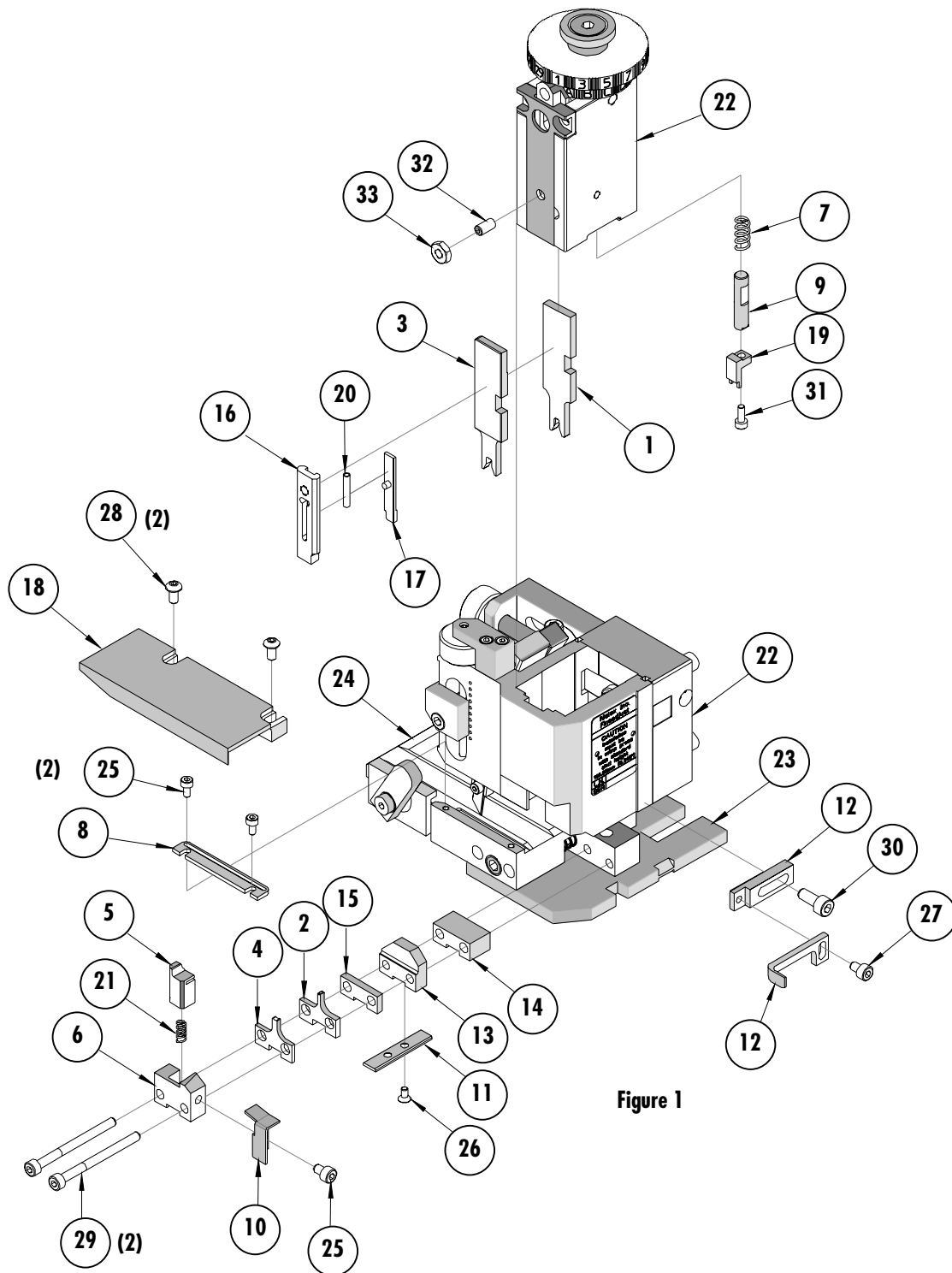

Figure 1

NOTES

1. Molex recommends an extra perishable tooling kit be maintained at your facility.
2. Verify tooling alignment by manually cycling the press and Applicator before crimping under power. Check that all screws are tight.
3. Slugs, Terminals, Dirt and Oil should be kept clear of work area.
4. Wear safety glasses at all times.
5. For recommended maintenance refer to the FineAdjust Manual.

CAUTION: This applicator should only be used in a press with a shut height of 135.8mm (5.346"). Tooling damage could result at a lower setting.

CAUTION: To prevent injury never operate this Applicator without the guards supplied with the press or wire-processing machine in place. Reference the press or wire processing manufacturer's instruction manual.

CAUTION: Molex crimp specifications are valid only when used with Molex terminals, applicators and tooling.

Americas Headquarters

Lisle, Illinois 60532 U.S.A.
1-800-78MOLEX
amerinfo@molex.com

Far East North Headquarters

Yamato, Kanagawa, Japan
81-462-65-2324
feninfo@molex.com

Far East South Headquarters

Jurong, Singapore
65-6-268-6868
fesinfo@molex.com

European Headquarters

Munich, Germany
49-89-413092-0
eurinfo@molex.com

Corporate Headquarters

2222 Wellington Ct.
Lisle, IL 60532 U.S.A.
630-969-4550
Fax: 630-969-1352

Visit our Web site at <http://www.molex.com>



Компания «ЭлектроПласт» предлагает заключение долгосрочных отношений при поставках импортных электронных компонентов на взаимовыгодных условиях!

Наши преимущества:

- Оперативные поставки широкого спектра электронных компонентов отечественного и импортного производства напрямую от производителей и с крупнейших мировых складов;
- Поставка более 17-ти миллионов наименований электронных компонентов;
- Поставка сложных, дефицитных, либо снятых с производства позиций;
- Оперативные сроки поставки под заказ (от 5 рабочих дней);
- Экспресс доставка в любую точку России;
- Техническая поддержка проекта, помощь в подборе аналогов, поставка прототипов;
- Система менеджмента качества сертифицирована по Международному стандарту ISO 9001;
- Лицензия ФСБ на осуществление работ с использованием сведений, составляющих государственную тайну;
- Поставка специализированных компонентов (Xilinx, Altera, Analog Devices, Intersil, Interpoint, Microsemi, Aeroflex, Peregrine, Syfer, Eurofarad, Texas Instrument, Miteq, Cobham, E2V, MA-COM, Hittite, Mini-Circuits, General Dynamics и др.);

Помимо этого, одним из направлений компании «ЭлектроПласт» является направление «Источники питания». Мы предлагаем Вам помощь Конструкторского отдела:

- Подбор оптимального решения, техническое обоснование при выборе компонента;
- Подбор аналогов;
- Консультации по применению компонента;
- Поставка образцов и прототипов;
- Техническая поддержка проекта;
- Защита от снятия компонента с производства.



Как с нами связаться

Телефон: 8 (812) 309 58 32 (многоканальный)

Факс: 8 (812) 320-02-42

Электронная почта: org@eplast1.ru

Адрес: 198099, г. Санкт-Петербург, ул. Калинина, дом 2, корпус 4, литера А.