

AC Line Rated Disc Capacitors Class X1, 760 V_{AC}, Class Y1, 500 V_{AC}

FEATURES

- Complying with IEC 60384-14, 3rd edition
- High reliability
- Vertical (inline) kinked or straight leads
- Material categorization:
For definitions of compliance please see www.vishay.com/doc?99912



RoHS
COMPLIANT
HALOGEN
FREE
Available

APPLICATIONS

- X1, Y1 according to IEC 60384-14.3
- Across-the-line
- Line by-pass
- Antenna coupling

DESIGN

The capacitors consist of a ceramic disc both sides of which are silver-plated. Connection leads are made of tinned copper having a diameter of 0.6 mm.

The capacitors may be supplied with vertical (inline) kinked leads having a lead spacing of 10.0 mm and 12.5 mm. Encapsulation is made of flammable resistant epoxy resin in accordance with “UL 94 V-0”.

QUICK REFERENCE DATA						
DESCRIPTION	CLASS X1 (U2J)	CLASS X1 (Y5S)	CLASS X1 (Y5U)	CLASS Y1 (U2J)	CLASS Y1 (Y5S)	CLASS Y1 (Y5U)
Voltage (V _{AC})	760			500	250	500
Min. Capacitance (pF)	10	33	470	10	33	470
Max. Capacitance (pF)	22	330	4700	22	330	4700
Mounting	Through hole					

OPERATING TEMPERATURE RANGE

- 40 °C to + 125 °C

TEMPERATURE CHARACTERISTICS

See Ordering Information table

CLIMATIC CATEGORY

40/125/21 according to EN 60068-1

COATING

According to UL 94 V-0

Epoxy resin, isolating, flame retardant

APPROVALS

ENEC VDE (DE1-32019)

UL 60384-14 file E183844

CSA 22.2

PACKAGING

Bulk, tape and reel, taped ammpack

CAPACITANCE RANGE

10 pF to 4700 pF

RATED VOLTAGE U_R

IEC 60384-14.3 and UL 60384-14:

(X1): 760 V_{AC}, 50 Hz

(Y1): 500 V_{AC}, 50 Hz

TEST VOLTAGE

Component test (100 %):

4000 V_{AC}, 50 Hz, 2 s

Random sampling test (destructive test):

4000 V_{AC}, 50 Hz, 60 s

Voltage proof of coating (destructive test):

4000 V_{AC}, 50 Hz, 60 s

INSULATION RESISTANCE

10 000 MΩ minimum

TOLERANCE OF CAPACITANCE

± 20 % (code M); ± 10 % (code K)

DISSIPATION FACTOR

2.5 % maximum

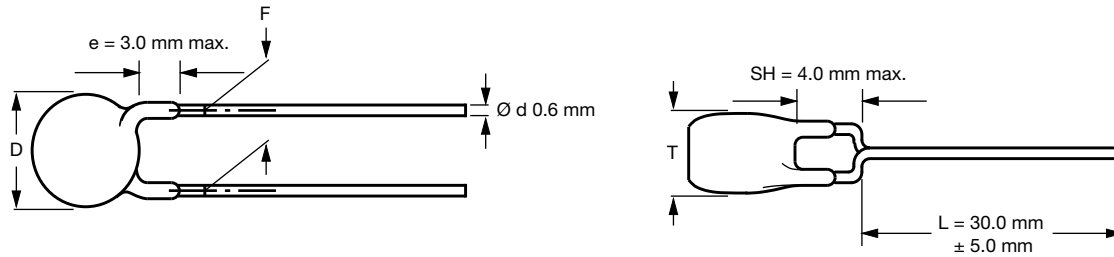
DIMENSIONS

Capacitors with 10.0 mm and 12.5 mm lead spacing

ORDERING INFORMATION

C (pF)	TOL. (%)	TEMP. COEFFICIENT	BODY DIAMETER $D_{MAX.}$ (mm)	BODY THICKNESS $T_{MAX.}$ (mm)	LEAD SPACING F (mm)	CLEAR TEXT CODE						
						15 TH DIGIT: T = REEL; U = AMMO; 3 = BULK ⁽¹⁾						
						RoHS COMPLIANT	RoHS AND HALOGEN-FREE					
10	± 10	U2J (N750)	8.0	5.0	10.0	VY1100K31U2JQ6*V0	VY1100K31U2JG6*V0					
15						VY1150K31U2JQ6*V0	VY1150K31U2JG6*V0					
22						VY1220K31U2JQ6*V0	VY1220K31U2JG6*V0					
33						VY1330K31Y5SQ6*V0	VY1330K31Y5SG6*V0					
47						VY1470K31Y5SQ6*V0	VY1470K31Y5SG6*V0					
68		Y5S (2C3)				VY1680K31Y5SQ6*V0	VY1680K31Y5SG6*V0					
100						VY1101K31Y5SQ6*V0	VY1101K31Y5SG6*V0					
150						VY1151K31Y5SQ6*V0	VY1151K31Y5SG6*V0					
220						VY1221K31Y5SQ6*V0	VY1221K31Y5SG6*V0					
330						VY1331K31Y5SQ6*V0	VY1331K31Y5SG6*V0					
470	± 20	Y5U (2E3)	9.0	5.0	10.0	VY1471M31Y5UQ6*V0	VY1471M31Y5UG6*V0					
680						VY1681M31Y5UQ6*V0	VY1681M31Y5UG6*V0					
1000						VY1102M35Y5UQ6*V0	VY1102M35Y5UG6*V0					
1500						VY1152M41Y5UQ6*V0	VY1152M41Y5UG6*V0					
2200						VY1222M47Y5UQ6*V0	VY1222M47Y5UG6*V0					
3300						VY1332M59Y5UQ6*V0	VY1332M59Y5UG6*V0					
3900						VY1392M61Y5UQ6*V0	VY1392M61Y5UG6*V0					
4700						VY1472M63Y5UQ6*V0	VY1472M63Y5UG6*V0					
10						± 10	U2J (N750)	8.0	5.0	12.5	VY1100K31U2JQ6*VX	VY1100K31U2JG6*VX
15											VY1150K31U2JQ6*VX	VY1150K31U2JG6*VX
22	VY1220K31U2JQ6*VX	VY1220K31U2JG6*VX										
33	VY1330K31Y5SQ6*VX	VY1330K31Y5SG6*VX										
47	VY1470K31Y5SQ6*VX	VY1470K31Y5SG6*VX										
68	Y5S (2C3)	VY1680K31Y5SQ6*VX	VY1680K31Y5SG6*VX									
100		VY1101K31Y5SQ6*VX	VY1101K31Y5SG6*VX									
150		VY1151K31Y5SQ6*VX	VY1151K31Y5SG6*VX									
220		VY1221K31Y5SQ6*VX	VY1221K31Y5SG6*VX									
330		VY1331K31Y5SQ6*VX	VY1331K31Y5SG6*VX									
470	± 20	Y5U (2E3)	9.0	5.0	12.5	VY1471M31Y5UQ6*VX	VY1471M31Y5UG6*VX					
680						VY1681M31Y5UQ6*VX	VY1681M31Y5UG6*VX					
1000						VY1102M35Y5UQ6*VX	VY1102M35Y5UG6*VX					
1500						VY1152M41Y5UQ6*VX	VY1152M41Y5UG6*VX					
2200						VY1222M47Y5UQ6*VX	VY1222M47Y5UG6*VX					
3300						VY1332M59Y5UQ6*VX	VY1332M59Y5UG6*VX					
3900						VY1392M61Y5UQ6*VX	VY1392M61Y5UG6*VX					
4700						VY1472M63Y5UQ6*VX	VY1472M63Y5UG6*VX					

Notes

- Straight leads are available on request
- Coating extension DR valid for straight leads only
- On request available: ± 10 % tolerance
- ⁽¹⁾ 15th digit of the clear text code number to be completed with the packaging code

PACKAGING					
CAPACITANCE VALUE	SIZE CODE	BODY DIAMETER $D_{MAX.}$ (mm)	PACKAGING QUANTITIES		
			BULK	REEL	AMMO
10 pF to 2200 pF	31 to 47	12.0	1000	500	750
3300 pF to 4700 pF	51 to 63	16.0	500	500	750

Note

- The capacitors are supplied in bulk packaging (cardboard boxes), in tape on reel in ammopack

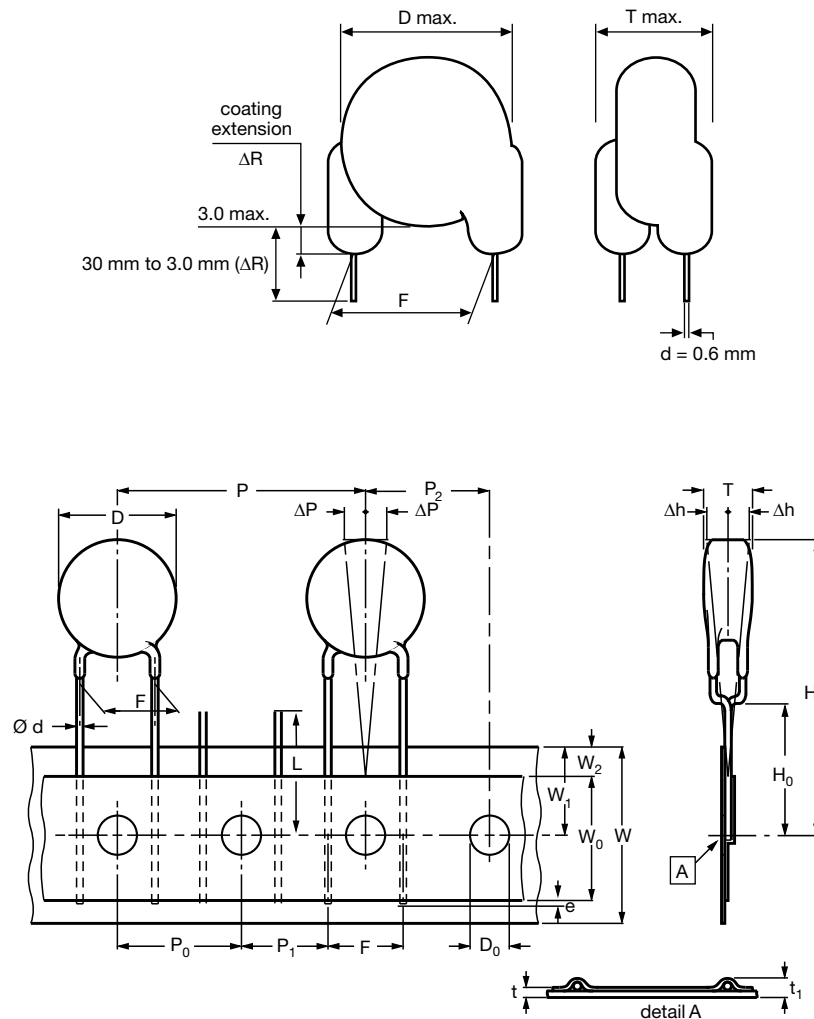
STRAIGHT LEADS

Lead spacing 10.0 mm and 12.5 mm, sprocket hole pitch 25.04 mm for lead spacing

DIMENSIONS OF TAPE		
SYMBOL	PARAMETER	DIMENSIONS (mm)
		FIG. 2
D ⁽¹⁾	Body diameter	16.0 max.
d	Lead diameter	0.6 ± 0.05
P	Pitch of component	25.4 ± 1
P ₀ ⁽²⁾	Pitch of sprocket hole	12.7 ± 0.3
P ₁ ⁽³⁾	Distance, hole center to lead	7.7 or 6.4 ± 1.0
P ₂ ⁽³⁾	Distance, hole to center of component	12.7 ± 1.5
F	Lead spacing	10.0 or 12.5 + 0.6/- 0.4
Δh	Average deviation across tape	± 1.0 max.
ΔP	Average deviation in direction of reeling	± 1.0 max.
W	Carrier tape width	18.0 + 1/- 0.5
W ₀	Hold-down tape width	5.0 min.
W ₁	Position of sprocket hole	9.0 + 0.75/- 0.5
W ₂	Distance of hold-down tape	3.0 max.
H ₁	Maximum component height	40.0
H ₀	Height to seating plane (for kinked leads)	16.0 ± 0.5
H ₀	Height to seating plane (for straight leads)	20.0 ± 0.5
L	Length of cut leads	11.0 max.
l	Length of lead protrusion	1.0 max.
D ₀	Diameter of sprocket hole	4.0 ± 0.2
t	Total tape thickness	0.9 max.

Notes

- (1) See Ordering Information table
- (2) Cumulative pitch error: ± 1 mm/20 pitches
- (3) Obliquity maximum 3°

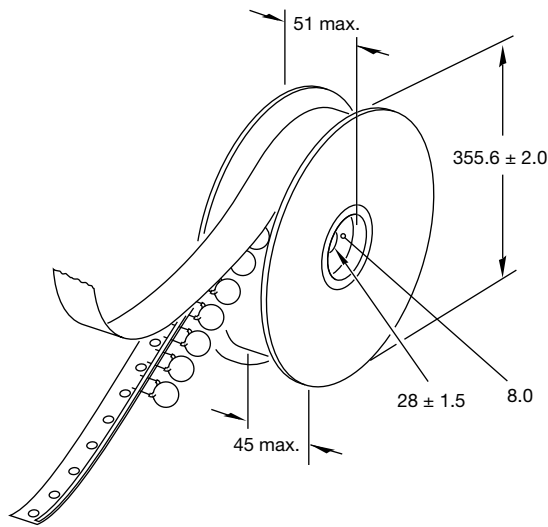
REEL AND TAPE DATA in millimeters

Reel with capacitors on tape

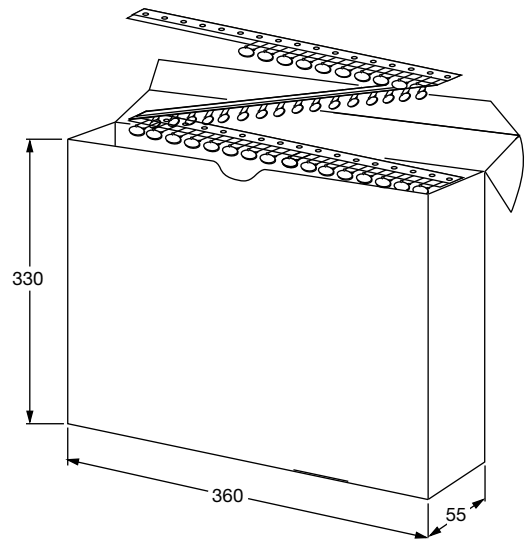

Ammpack with capacitors on tape



STANDARD RECOGNITION

IEC 60384 - 14/3rd issue (2005) - Safety tests
UL 1414 - Across-the-line, antenna-coupling and line-by-pass component
CSA C22.2 - Across-the-line, line to ground and antenna isolation capacitor
CQC - China Quality Certification Center-Safety Tests

MARKING: 2 SIDES (EXAMPLE)

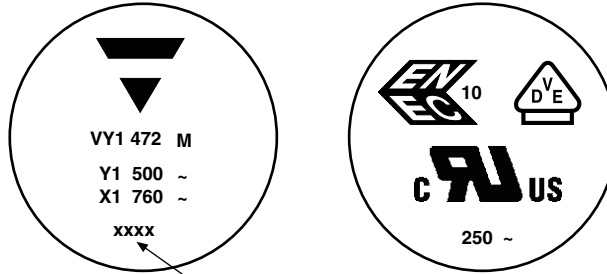

4 digit date code (year/week)

LABEL (EXAMPLE)

Barcode, Vishay logo, and technical data: PN: VY1471M31Y5UQ6XT0, Lot1: 14Z551S12, DC1: 0601, QTY: 225, Lot2:, DC2:, PO:, Batch: 200601CN, SO:, Region: 9520, SL: 0010, Ser.No: 0601H69340. Includes RoHS and 1/1 markings.

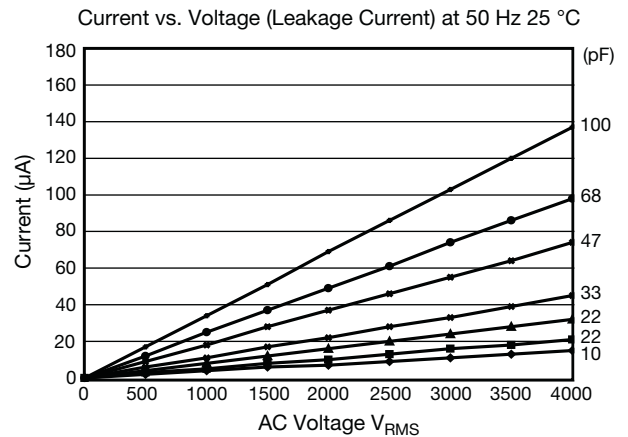
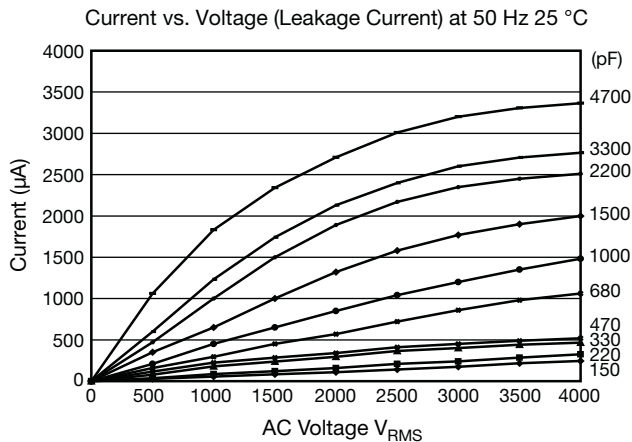

Note

- The capacitors meet the essential requirements of "EIA 198". Unless stated otherwise all electrical values apply at an ambient temperature of 25 °C ± 3 °C, at normal atmospheric conditions.



Disclaimer

ALL PRODUCT, PRODUCT SPECIFICATIONS AND DATA ARE SUBJECT TO CHANGE WITHOUT NOTICE TO IMPROVE RELIABILITY, FUNCTION OR DESIGN OR OTHERWISE.

Vishay Intertechnology, Inc., its affiliates, agents, and employees, and all persons acting on its or their behalf (collectively, "Vishay"), disclaim any and all liability for any errors, inaccuracies or incompleteness contained in any datasheet or in any other disclosure relating to any product.

Vishay makes no warranty, representation or guarantee regarding the suitability of the products for any particular purpose or the continuing production of any product. To the maximum extent permitted by applicable law, Vishay disclaims (i) any and all liability arising out of the application or use of any product, (ii) any and all liability, including without limitation special, consequential or incidental damages, and (iii) any and all implied warranties, including warranties of fitness for particular purpose, non-infringement and merchantability.

Statements regarding the suitability of products for certain types of applications are based on Vishay's knowledge of typical requirements that are often placed on Vishay products in generic applications. Such statements are not binding statements about the suitability of products for a particular application. It is the customer's responsibility to validate that a particular product with the properties described in the product specification is suitable for use in a particular application. Parameters provided in datasheets and/or specifications may vary in different applications and performance may vary over time. All operating parameters, including typical parameters, must be validated for each customer application by the customer's technical experts. Product specifications do not expand or otherwise modify Vishay's terms and conditions of purchase, including but not limited to the warranty expressed therein.

Except as expressly indicated in writing, Vishay products are not designed for use in medical, life-saving, or life-sustaining applications or for any other application in which the failure of the Vishay product could result in personal injury or death. Customers using or selling Vishay products not expressly indicated for use in such applications do so at their own risk. Please contact authorized Vishay personnel to obtain written terms and conditions regarding products designed for such applications.

No license, express or implied, by estoppel or otherwise, to any intellectual property rights is granted by this document or by any conduct of Vishay. Product names and markings noted herein may be trademarks of their respective owners.

Material Category Policy

Vishay Intertechnology, Inc. hereby certifies that all its products that are identified as RoHS-Compliant fulfill the definitions and restrictions defined under Directive 2011/65/EU of The European Parliament and of the Council of June 8, 2011 on the restriction of the use of certain hazardous substances in electrical and electronic equipment (EEE) - recast, unless otherwise specified as non-compliant.

Please note that some Vishay documentation may still make reference to RoHS Directive 2002/95/EC. We confirm that all the products identified as being compliant to Directive 2002/95/EC conform to Directive 2011/65/EU.

Vishay Intertechnology, Inc. hereby certifies that all its products that are identified as Halogen-Free follow Halogen-Free requirements as per JEDEC JS709A standards. Please note that some Vishay documentation may still make reference to the IEC 61249-2-21 definition. We confirm that all the products identified as being compliant to IEC 61249-2-21 conform to JEDEC JS709A standards.



Компания «ЭлектроПласт» предлагает заключение долгосрочных отношений при поставках импортных электронных компонентов на взаимовыгодных условиях!

Наши преимущества:

- Оперативные поставки широкого спектра электронных компонентов отечественного и импортного производства напрямую от производителей и с крупнейших мировых складов;
- Поставка более 17-ти миллионов наименований электронных компонентов;
- Поставка сложных, дефицитных, либо снятых с производства позиций;
- Оперативные сроки поставки под заказ (от 5 рабочих дней);
- Экспресс доставка в любую точку России;
- Техническая поддержка проекта, помощь в подборе аналогов, поставка прототипов;
- Система менеджмента качества сертифицирована по Международному стандарту ISO 9001;
- Лицензия ФСБ на осуществление работ с использованием сведений, составляющих государственную тайну;
- Поставка специализированных компонентов (Xilinx, Altera, Analog Devices, Intersil, Interpoint, Microsemi, Aeroflex, Peregrine, Syfer, Eurofarad, Texas Instrument, Miteq, Cobham, E2V, MA-COM, Hittite, Mini-Circuits, General Dynamics и др.);

Помимо этого, одним из направлений компании «ЭлектроПласт» является направление «Источники питания». Мы предлагаем Вам помощь Конструкторского отдела:

- Подбор оптимального решения, техническое обоснование при выборе компонента;
- Подбор аналогов;
- Консультации по применению компонента;
- Поставка образцов и прототипов;
- Техническая поддержка проекта;
- Защита от снятия компонента с производства.



Как с нами связаться

Телефон: 8 (812) 309 58 32 (многоканальный)

Факс: 8 (812) 320-02-42

Электронная почта: org@eplast1.ru

Адрес: 198099, г. Санкт-Петербург, ул. Калинина, дом 2, корпус 4, литера А.