

Current-compensated Chokes



- Rated currents from 16 to 50 A
- Up to 600 VAC or 1000 VDC
- 2- and 3-wire configurations
- Horizontal and vertical PCB mounting types
- Ruggedized saturation and thermal behavior
- Open construction for forced and convection cooling
- Straightforward pin-out for easy PCB design



Performance indicators

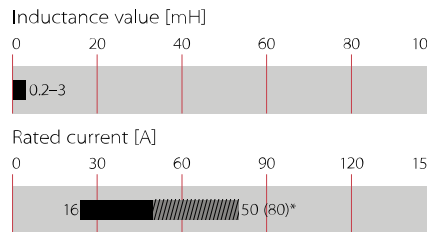

Technical specifications

Maximum continuous operating voltage	600 VAC/1000 VDC
Operating frequency	DC to 400 Hz
Rated currents	16 to 50 A @ 60°C max. convection cooling
High potential test voltage	
winding-to-winding	2500 VAC, 60 sec, guaranteed, 2 sec factory test
Temperature range (operation and storage)	-40°C to +125°C (40/125/21)
Flammability corresponding to	UL 94 V-0
Cooling	convection/forced cooling
MTBF @ 40°C/230 V (Mil-HB-217F)	>5,000,000 hours

Approvals

ROHS

RB common-mode chokes are mainly used to filter EMI noise on AC power lines up to 600 VAC but they are as well applicable in DC power lines of photovoltaic installations or similar applications up to 1000 VDC. EMI noise of electronic equipment can go to the power lines and disturb the proper function of other devices like TV sets or radios. Thus noise generated by the equipment from switched power electronics or by high slew rates of controllers needs to be filtered. RB common-mode chokes are used to suppress EMI noise in PCB integrated filter designs with line bypass capacitors or in combination with single phase filters for extra low leakage filter designs.

Features and benefits

- Cost-effective PCB designs for up to 80 A with forced cooling *
- Compact size and light weight
- Low magnetic leakage flux
- Excellent winding insulation
- Standardized foot print
- Broad range of inductance ratings
- Custom-specific versions on request
- Evaluation Board and PCB footprints available

* See Application Note for forced cooling

Typical applications

- AC and DC filtering for midsize power range drives, photovoltaic inverters, fast chargers, charging stations, UPS and switch mode power supplies
- Filter with low leakage current noise or improved immunity against grid disturbances
- Electronic devices, automation
- Converters

Typical electrical schematic

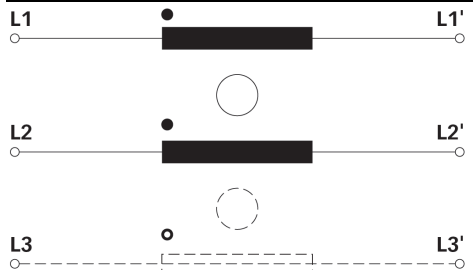

RB Series

Selection table	convection	*forced cooling	Inductance	Inductance	Resistance	**Choke	Ø Pin	Length	Weight	Eval.
	cooling nominal current @ 60°C [A]	3 m/s nominal current @ 60°C [A]	Ln @ 25°C [mH/path]	Ls @ 25°C [µH/path]	R @ 25°C [mΩ/path]	[size]	D [mm]	Pin [mm]	[g]	Board No.
RB 6122-16-1M0	16	25	1.00	6.3	4.8	1	2.0 ±0.1	4.5 ±0.5	130	1
RB 6122-25-0M6	25	39	0.64	4.0	2.7	1	2.4 ±0.1	4.5 ±0.5	135	1
RB 6122-36-0M5	36	53	0.45	3.6	1.5	2	2.2 ±0.1	4.5 ±0.5	180	1
RB 6122-50-0M3	50	80	0.25	1.8	0.9	2	2.5 ±0.1	5.0 ±0.5	172	1
RB 6522-16-1M0	16	25	1.00	6.2	4.6	3	2.0 ±0.1	4.5 ±0.5	132	2
RB 6522-25-0M6	25	39	0.64	3.9	2.6	3	2.4 ±0.1	4.5 ±0.5	126	2
RB 6522-36-0M5	36	53	0.45	3.6	1.5	4	2.2 ±0.1	4.5 ±0.5	180	2
RB 6522-50-0M3	50	80	0.25	2.0	0.9	4	2.5 ±0.1	5.0 ±0.5	175	2
RB 8522-16-3M0	16	25	3.00	22.2	8.4	4	2.0 ±0.1	4.5 ±0.5	172	3
RB 8522-25-2M0	25	39	2.00	13.6	4.2	5	2.65 ±0.1	5.0 ±0.5	268	3
RB 8522-36-1M5	36	53	1.50	12.8	3.0	6	2.2 ±0.1	4.5 ±0.5	440	3
RB 8522-50-0M8	50	83	0.75	6.5	1.7	6	2.5 ±0.1	5.0 ±0.5	430	3
RB 6132-16-0M8	16	26.5	0.80	5.8	4.6	7	2.0 ±0.1	4.5 ±0.5	162	4
RB 6132-25-0M5	25	41	0.47	3.3	2.4	7	2.5 ±0.1	5.0 ±0.5	175	4
RB 6132-36-0M4	36	60	0.42	2.9	1.4	8	2.2 ±0.1	4.5 ±0.5	278	5
RB 6132-50-0M2	50	80	0.18	1.9	0.9	8	2.5 ±0.1	5.0 ±0.5	765	5
RB 6532-16-0M8	16	26.5	0.80	6.9	4.7	9	2.0 ±0.1	4.5 ±0.5	165	6
RB 6532-25-0M5	25	41	0.47	3.6	2.4	9	2.5 ±0.1	5.0 ±0.5	180	6
RB 6532-36-0M4	36	60	0.42	4.2	1.5	10	2.2 ±0.1	4.5 ±0.5	280	6
RB 6532-50-0M2	50	81	0.18	1.5	0.8	10	2.5 ±0.1	5.0 ±0.5	168	6
RB 8532-16-1M3	16	27	1.30	9.1	5.7	9	2.0 ±0.1	4.5 ±0.5	167	7
RB 8532-25-0M9	25	41	0.94	6.7	3.0	11	2.65 ±0.1	5.0 ±0.5	282	7
RB 8532-36-0M8	36	58	0.83	7.3	2.3	12	2.2 ±0.1	4.5 ±0.5	478	7
RB 8532-50-0M3	50	82	0.33	3.1	1.2	12	2.5 ±0.1	5.0 ±0.5	442	7

Test conditions:

Measuring frequency: 1 kHz; 500 µA >0.16 mH <1.6 mH; 50 µA >1.6 mH <160 mH

Inductance tolerance: +50%, -30%

Resistance tolerance: ±15% @ 25°C

Electrical characteristics @ 25°C: ±2°C

* typical current for forced cooling with 3 m/s. Due to the possible turbulences and degradation of the air stream within an equipment please consider thermal validation.

** Due to manufacturing processes and to cover current ampacity of chokes with high current rating, the number of parallel wires does vary between different sizes.

Typical choke attenuation/resonance frequency characteristics

Per CISPR 17; 50 Ω/50 Ω asym

RB 6122, RB 6522

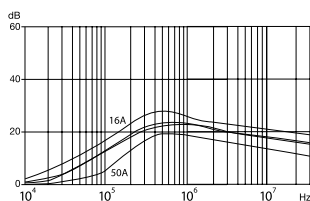

RB 6132, RB 6532

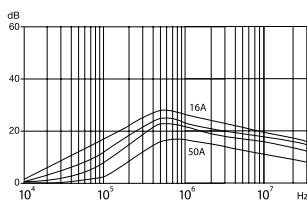

RB 8522

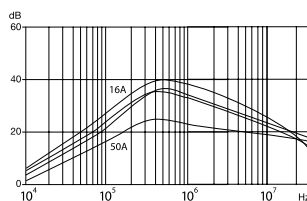

RB 8532

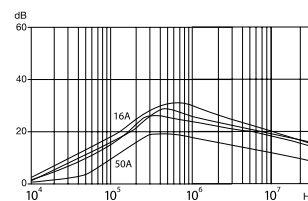

Product selector

RB xxxx-xx-xmx

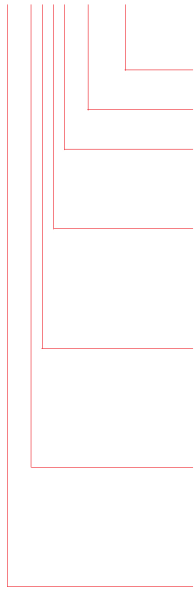

- Inductance value (e.g. 9M6 = 9.6 mH)
- Nominal input current [A] (convection cooling)
- Terminal type (2 for PCB pin)

- 2 = 2-wire choke
- 3 = 3-wire choke

- 1 = Horizontal
- 5 = Vertical

- 8 = high inductance series
- 6 = low inductance series

- Schaffner standard ring-core choke series RB

Examples:

RB 8532-16-1M3: Vertical 3-wire high inductance choke with PCB pins, for 16 A, with 1.3 mH

RB 6122-50-0M3: Horizontal 2-wire low inductance choke with PCB pins, for 50 A, with 0.3 mH

Mechanical data: 1-phase / DC chokes

All dimensions in mm

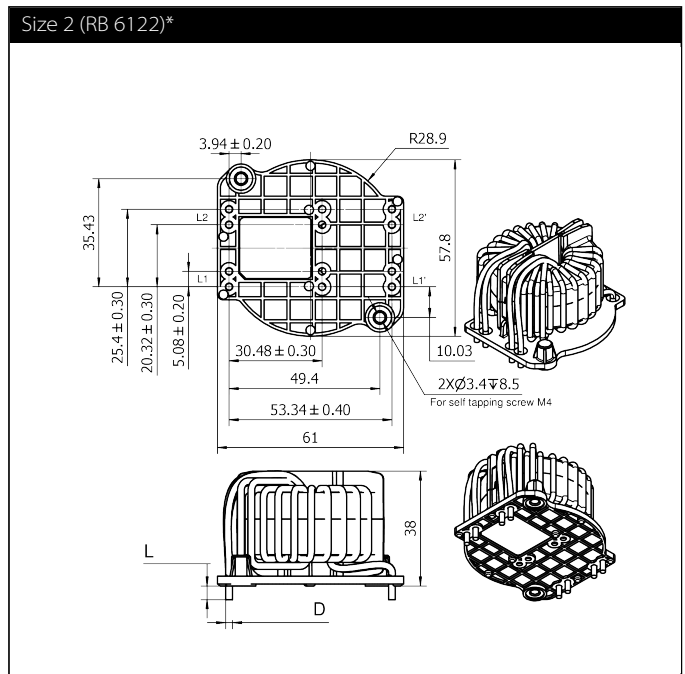
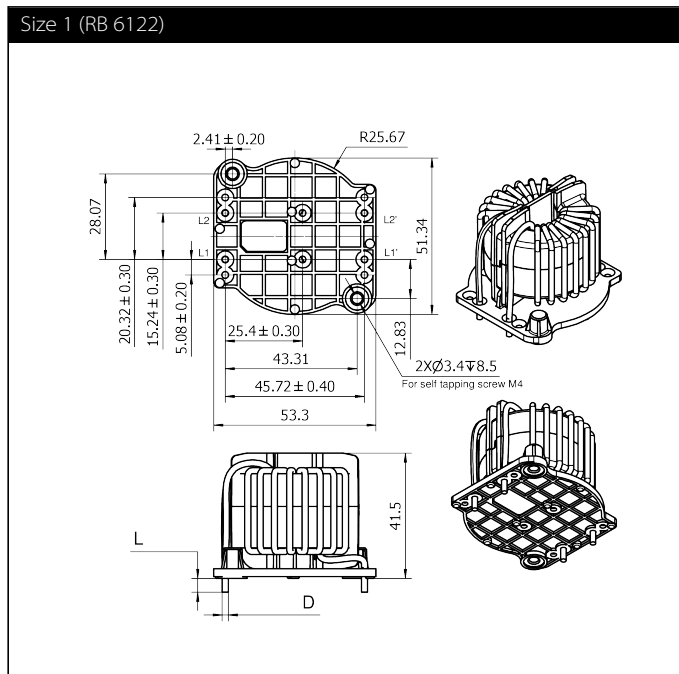

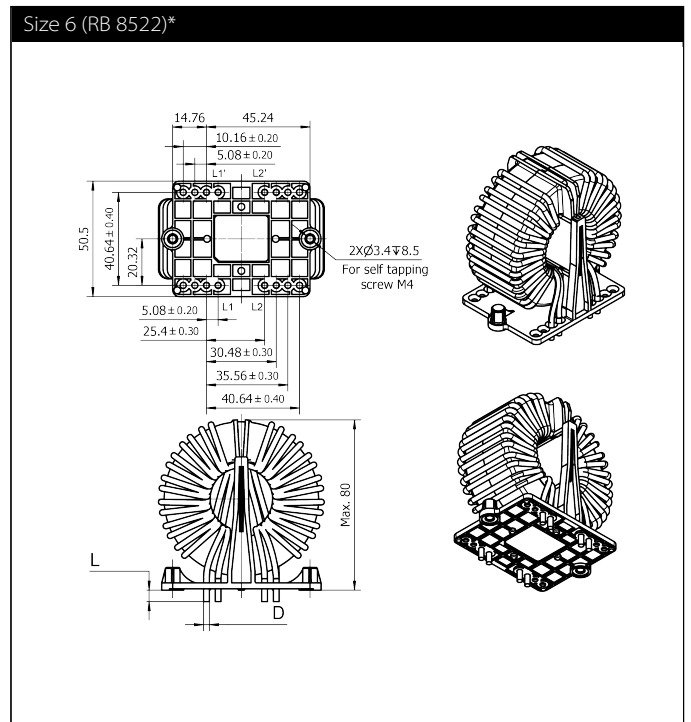
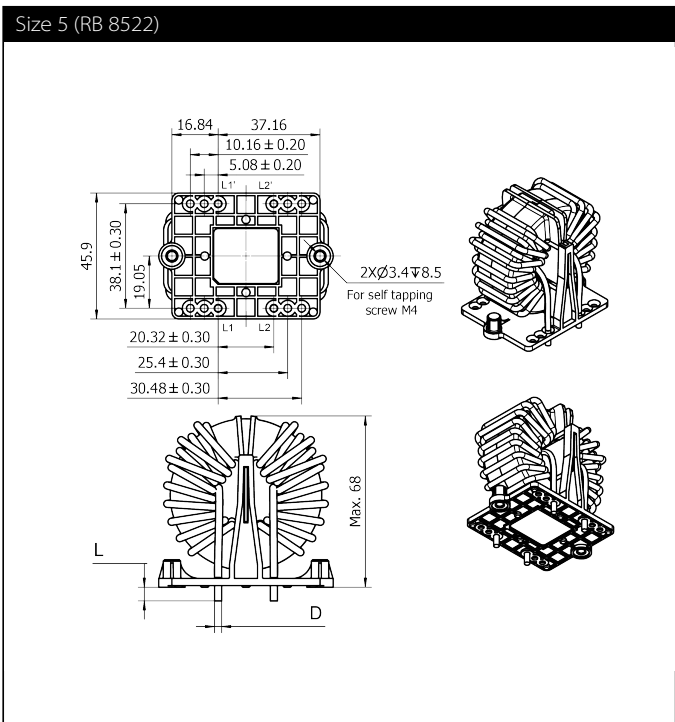
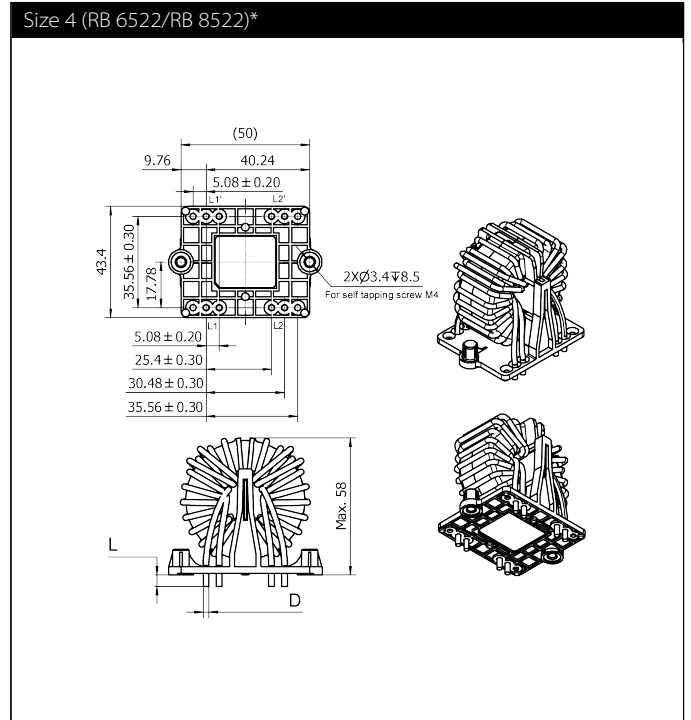
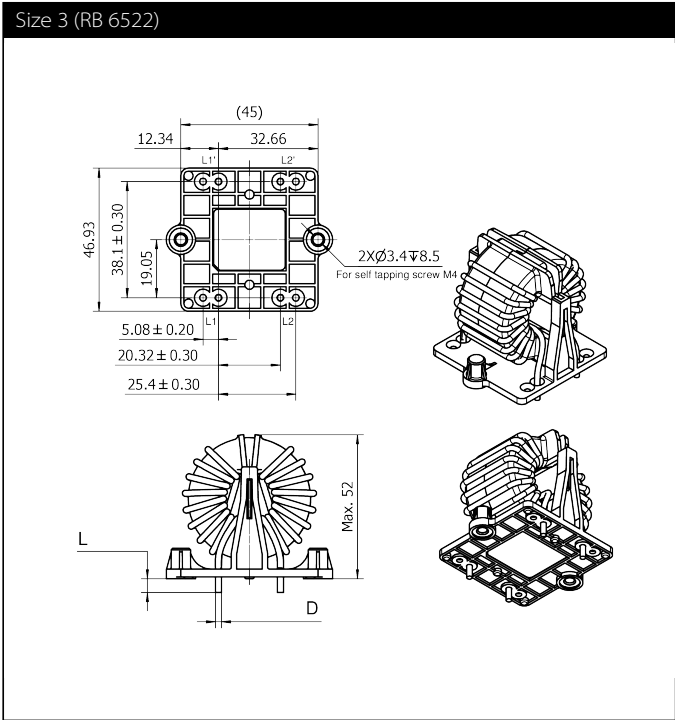

* These choke sizes do have two parallel wires. Due to manufacturing processes and to cover current ampacity of chokes with high current rating, the number of parallel wires does vary between different sizes.

Mechanical data: 3-phase chokes

All dimensions in mm

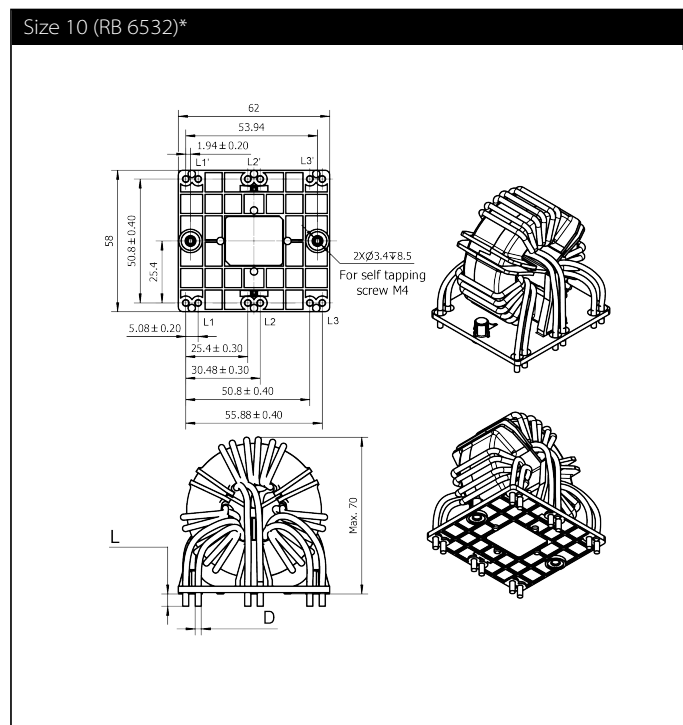
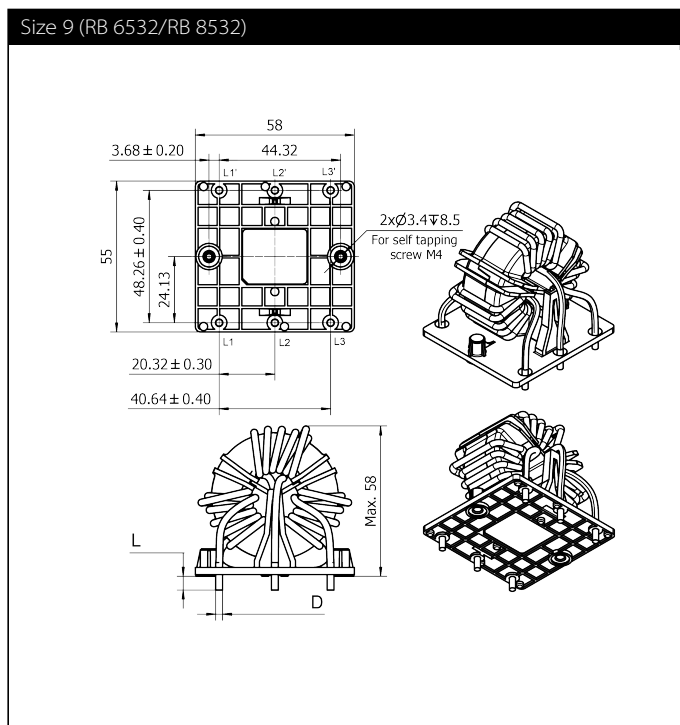
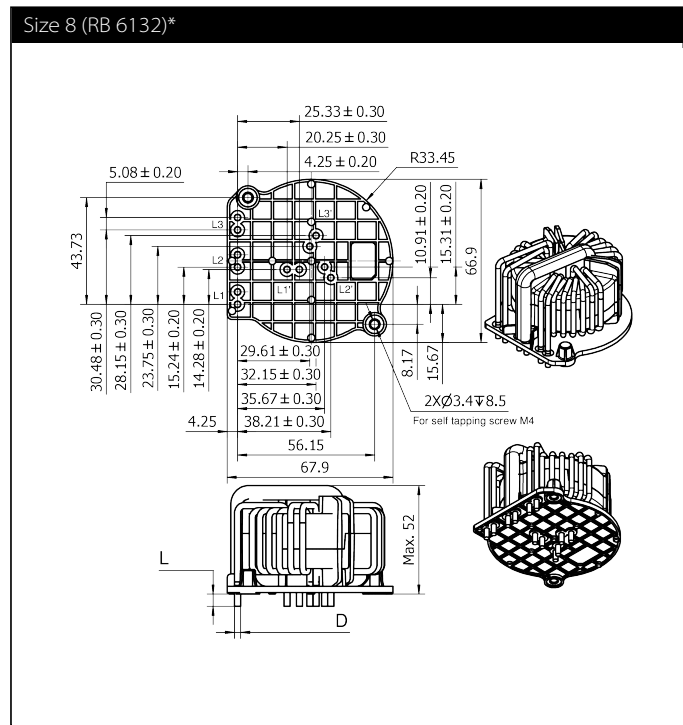
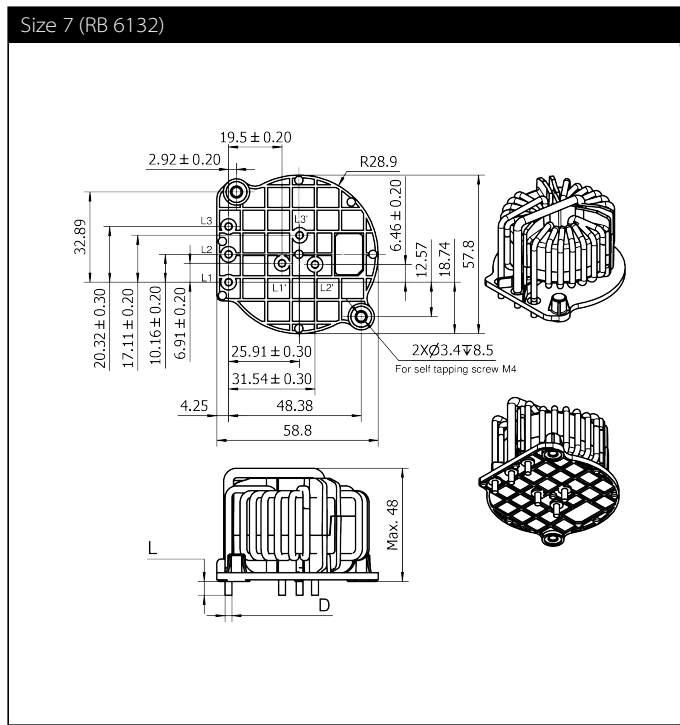

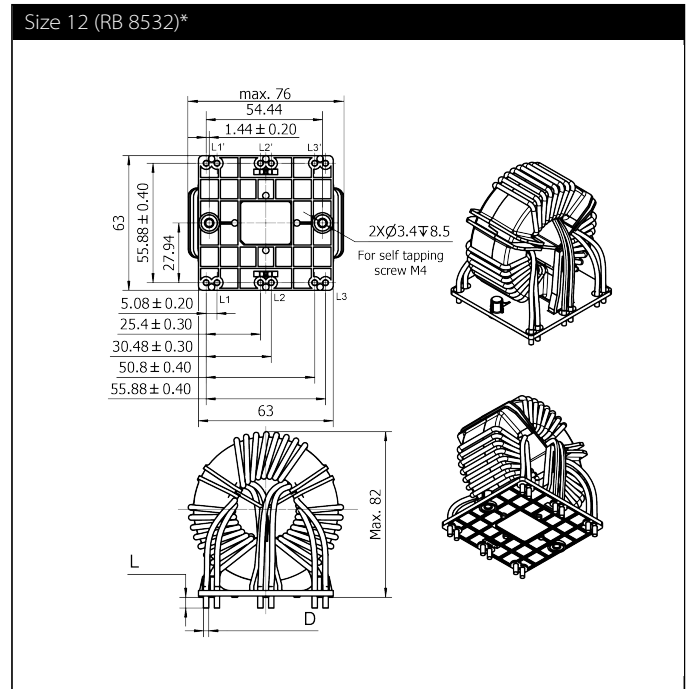
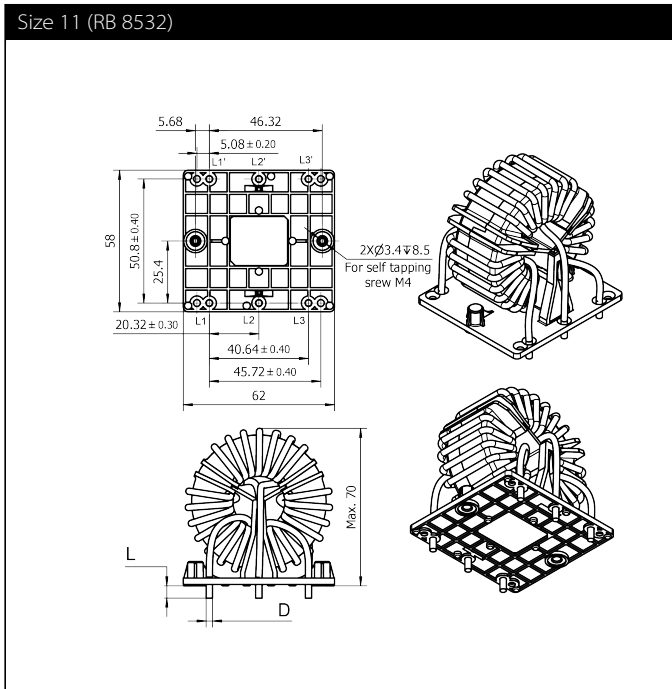

* These choke sizes do not have two parallel wires. Due to manufacturing processes and to cover current ampacity of chokes with high current rating, the number of parallel wires does vary between different sizes.

Available Supporting Material

Accessories

For all RB choke types an evaluation board is available (not including capacitors and RB chokes)

All boards feature voltage ratings according to the chokes usable on the board - up to 600VAC/1000VDC.

The capacitors used need to be selected according to application and safety level. Recommended are Y1 and X1 capacitors with a voltage rating of at least 600VAC and 1000VDC.

The pitch for Y-capacitors (between phase and PE) is 15 or 22.5 mm. With a max outer dimension of 12 x 26 mm (w x l).

The pitch for X-capacitors (between phases) is 22.5, 27.5 or 37.5 mm. With a max outer dimension of 28 x 40 mm (w x l).

For discharge reason a resistor can be fitted in parallel to the X-capacitors.

All connections to the boards are done with M6 screw terminals (recommended torque is 2.5 Nm).

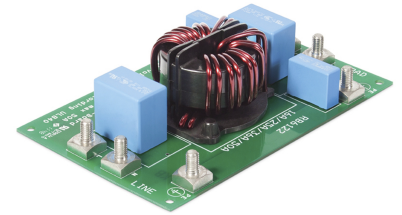

Selection table	Nom. Current of RB Choke	Eval. Board	Order Name	Order Code
RB Choke Type	[Range A]	No		
[RB XXXX]				
RB 6122	16 - 50	1	EVA-BOARD FOR RB6122 SERIES	813249
RB 6522	16 - 50	2	EVA-BOARD FOR RB6522 SERIES	813252
RB 8522	16 - 50	3	EVA-BOARD FOR RB8522 SERIES	813254
RB 6132	16 - 25	4	EVA-BOARD FOR RB6132-16/25	813250
RB 6132	36 - 50	5	EVA-BOARD FOR RB6132-36/50	813251
RB 6532	16 - 50	6	EVA-BOARD FOR RB6532 SERIES	813253
RB 8532	16 - 50	7	EVA-BOARD FOR RB8532 SERIES	813255

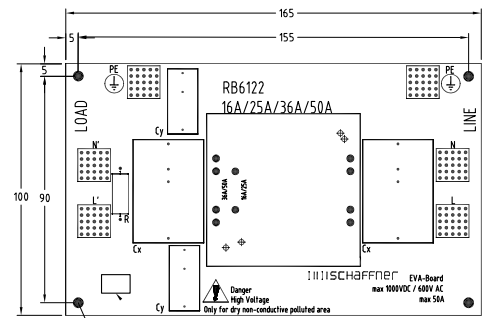

For further drawings and CAD data of the different boards please contact your local Schaffner subsidiary.

Application Note

EMC/EMI Filter Design with RB Common Mode-Chokes

This application note addresses experienced engineers, who are familiar with the basics of EMC, and intends to provide additional information about RB choke series and Design support for PCB integrated EMC/EMI filters.

[Link to PDF](#)



Headquarters, global innovation and development

Switzerland

Schaffner Group

Nordstrasse 11
4542 Luterbach
T +41 32 681 66 26
info@schaffner.com



Sales and application centers

China

Schaffner EMC Ltd. Shanghai

T20-3 C, No 565 Chuangye Road,
Pudong district
201201 Shanghai
T +86 21 3813 9500
cschina@schaffner.com
www.schaffner.com.cn

Finland

Schaffner Oy

Sauvonrinne 19 H
08500 Lohja
T +358 10 567 2855
finlandsales@schaffner.com

France

Schaffner EMC S.A.S.

16-20 Rue Louis Rameau
95875 Bezons
T +33 1 34 34 30 60
F +33 1 39 47 02 28
francesales@schaffner.com

Germany

Schaffner Deutschland GmbH

Schoemperlenstrasse 12B
76185 Karlsruhe
T +49 721 56910
F +49 721 569110
germanysales@schaffner.com

India

Schaffner India Pvt. Ltd

REGUS WORLD TRADE CENTRE
WTC, 22nd Floor Unit No 2238, Brigade
Gateway Campus, 26/1, Dr. Rajkumar Road
Malleshwaram (W)
560055 Bangalore
T +91 80 67935355
indiasales@schaffner.com

Italy

Schaffner EMC S.r.l.

Via Ticino, 30
20900 Monza (MB)
T +39 039 21 41 070
italysales@schaffner.com

Japan

Schaffner EMC K.K.

1-32-12, Kamiyama, Setagaya-ku
7F Mitsui-seimei Sangenjaya Bldg.
154-0011 Tokyo
T +81 3 5712 3650
F +81 3 5712 3651
japansales@schaffner.com
www.schaffner.jp

Singapore

Schaffner EMC Pte Ltd.

#05-09, Kg Ubi Ind. Estate
408705 Singapore
T +65 6377 3283
F +65 6377 3281
singaporesales@schaffner.com

Spain

Schaffner EMC España

Calle Caléndula 93, Miniparc III, Edificio E
El Soto de Moraleja, Alcobendas
28109 Madrid
T +34 917 912 900
F +34 917 912 901
spainsales@schaffner.com

Sweden

Schaffner EMC AB

Tegeluddsvägen 76, 2tr
115 28 Stockholm
T +46 8 5050 2425
swedensales@schaffner.com
www.schaffner.com

Switzerland

Schaffner EMV AG

Nordstrasse 11
4542 Luterbach
T +41 32 681 66 26
switzerlandsales@schaffner.com

Taiwan R.O.C.

Schaffner EMV Ltd.

20 Floor-2, No 97, Section 1, XinTai 5th Road
22175 XiZhi District New Taipei City 22175
T +886 2 2697 5500
F +886 2 2697 5533
taiwansales@schaffner.com
www.schaffner.com.tw

Thailand

Schaffner EMC Co. Ltd.

Northern Region Industrial Estate
67 Moo 4 Tambon Ban Klang
Amphur Muangng P.O. Box 14
51000 Lamphun
T +66 53 58 11 04
F +66 53 58 10 19
thailandsales@schaffner.com

United Kingdom

Schaffner Ltd.

5 Ashville Way, Molly Millars Lane
Wokingham
RG41 2PL Berkshire
T +44 118 9770070
F +44 118 9792969
uksales@schaffner.com

USA

Schaffner EMC Inc.

52 Mayfield Avenue
Edison, New Jersey
T +1 732 225 9533
F +1 732 225 4789
usasales@schaffner.com
www.schaffnerusa.com

Schaffner North America

6722 Thirlane Road
24019 Roanoke, Virginia
T +1 276 228 7943
F +1 276 228 7953

Schaffner North America

823 Fairview Road
24382 Wytheville, Virginia
T +1 276 228 7943
F +1 276 228 7258

To find your local partner within Schaffner's global network: www.schaffner.com

© 2018 Schaffner Group

The content of this document has been carefully checked and understood. However, neither Schaffner nor its subsidiaries assume any liability whatsoever for any errors or inaccuracies of this document and the consequences thereof. Published specifications are subject to change without notice. Product suitability for any area of application must ultimately be determined by the customer. In all cases, products must never be operated outside their published specifications. Schaffner does not guarantee the availability of all published products. This disclaimer shall be governed by substantive Swiss law and resulting disputes shall be settled by the courts at the place of business of Schaffner Holding AG. Latest publications and a complete disclaimer can be downloaded from the Schaffner website. All trademarks recognized.



Компания «ЭлектроПласт» предлагает заключение долгосрочных отношений при поставках импортных электронных компонентов на взаимовыгодных условиях!

Наши преимущества:

- Оперативные поставки широкого спектра электронных компонентов отечественного и импортного производства напрямую от производителей и с крупнейших мировых складов;
- Поставка более 17-ти миллионов наименований электронных компонентов;
- Поставка сложных, дефицитных, либо снятых с производства позиций;
- Оперативные сроки поставки под заказ (от 5 рабочих дней);
- Экспресс доставка в любую точку России;
- Техническая поддержка проекта, помощь в подборе аналогов, поставка прототипов;
- Система менеджмента качества сертифицирована по Международному стандарту ISO 9001;
- Лицензия ФСБ на осуществление работ с использованием сведений, составляющих государственную тайну;
- Поставка специализированных компонентов (Xilinx, Altera, Analog Devices, Intersil, Interpoint, Microsemi, Aeroflex, Peregrine, Syfer, Eurofarad, Texas Instrument, Miteq, Cobham, E2V, MA-COM, Hittite, Mini-Circuits, General Dynamics и др.);

Помимо этого, одним из направлений компании «ЭлектроПласт» является направление «Источники питания». Мы предлагаем Вам помощь Конструкторского отдела:

- Подбор оптимального решения, техническое обоснование при выборе компонента;
- Подбор аналогов;
- Консультации по применению компонента;
- Поставка образцов и прототипов;
- Техническая поддержка проекта;
- Защита от снятия компонента с производства.



Как с нами связаться

Телефон: 8 (812) 309 58 32 (многоканальный)

Факс: 8 (812) 320-02-42

Электронная почта: org@eplast1.ru

Адрес: 198099, г. Санкт-Петербург, ул. Калинина, дом 2, корпус 4, литера А.