

REVISIONS						
P	LTR	DESCRIPTION	DATE	DMN	APVD	
AA2		REVISED PER ECO-11-004587	11MAR11	RK	HMR	
AB		REVISED PER ECO-17-002209	11APR2017	RS	MM	

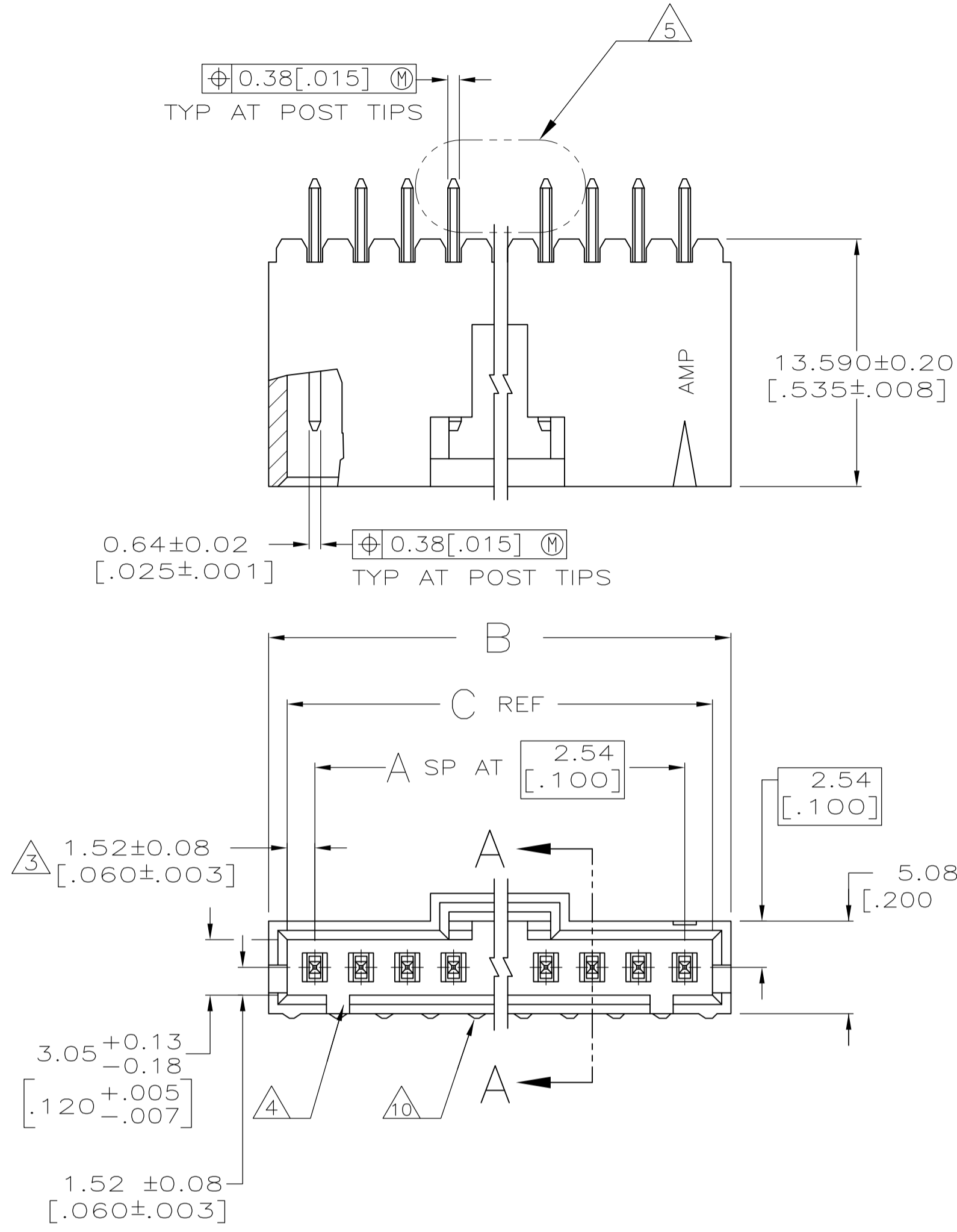

DETAIL Z  
POST DETAIL TYP  
2 POST MINIMUM

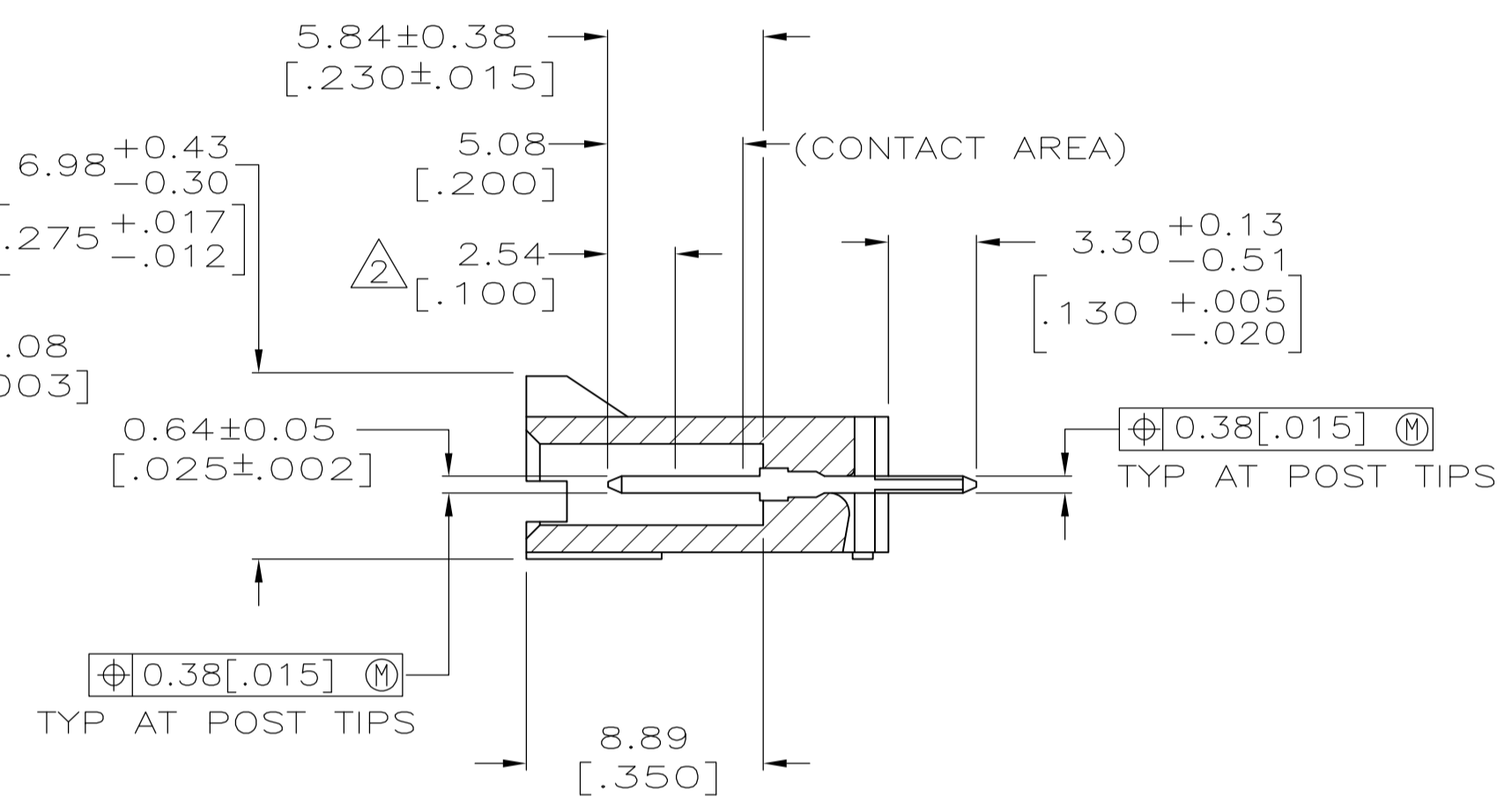

SECTION A-A

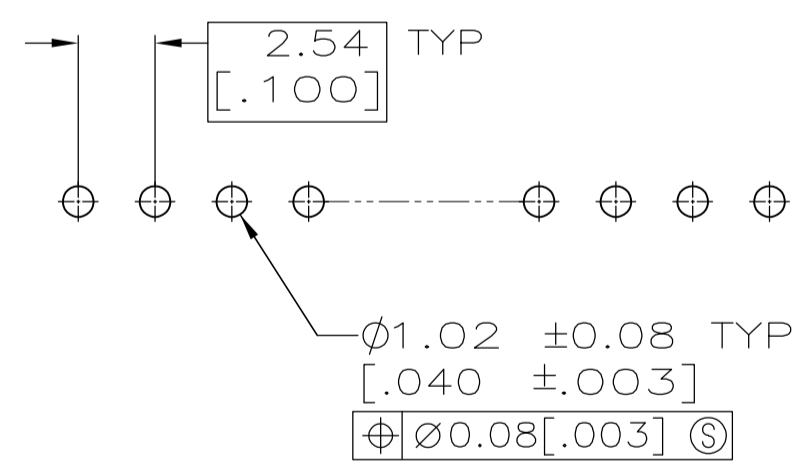

RECOMMENDED HOLE LAYOUT

- 1. .000100 BRIGHT TIN-LEAD OVER .000050 NICKEL.
- 2. POINT OF MEASUREMENT FOR PLATING THICKNESS.
- 3. THE NOTED DIMENSIONS APPLY AT THE INTERSECTION OF THE POST AND THE HOUSING.
- 4. ON ASSEMBLIES WITH FOUR OR MORE POSITIONS, TWO POLARIZATION SLOTS. ON ASSEMBLIES WITH TWO OR THREE POSITIONS, ONE POLARIZATION SLOT.
- 5. SELECT POST TAILS FORMED TO PROVIDE CONNECTOR HOLD DOWN UNTIL SOLDERED. CONFIGURATION ACCEPTS 0.69[.027]-2.03[.080] THICK PRINTED CIRCUIT BOARD. ( SEE DETAIL Z ).
- 6. .000100 BRIGHT TIN OVER .000050 NICKEL.
- 7. PRELIMINARY PART - NOT RELEASED FOR PRODUCTION.
- 8. .000100 MATTE TIN OVER .000050 NICKEL.
- 9. HIGH TEMPERATURE CONFIGURATION.
- 10. STANDOFFS NOT PRESENT ON UNDERSIDE OF ASSEMBLY
- 11. OBSOLETE PARTS: OBSOLETE CIS STREAMLINING PER D.RENAUD/D.SINISI

REMARKS	PLATING	C	B	A	NO. OF POSN	PART NO.
9	6	23.37 [0.920]	25.27 [0.995]	8	9	3-103669-0
9	6	8.13 [0.320]	10.03 [0.395]	2	3	2-103669-9
9	6	15.75 [0.620]	17.65 [0.695]	5	6	2-103669-8
9	6	13.21 [0.520]	15.11 [0.595]	4	5	2-103669-7
9	6	10.67 [0.420]	12.57 [0.495]	3	4	2-103669-6
9	6	5.59 [0.220]	7.49 [0.295]	1	2	2-103669-5
11	9	64.01 [2.520]	65.91 [2.595]	24	25	2-103669-4
11	9	61.47 [2.420]	63.37 [2.495]	23	24	2-103669-3
11	9	58.93 [2.320]	60.83 [2.395]	22	23	2-103669-2
11	9	56.39 [2.220]	58.29 [2.295]	21	22	2-103669-1
11	9	53.85 [2.120]	55.75 [2.195]	20	21	2-103669-0
9	1	51.31 [2.020]	53.21 [2.095]	19	20	1-103669-9
11	9	48.77 [1.920]	50.67 [1.995]	18	19	1-103669-8
11	9	46.23 [1.820]	48.13 [1.895]	17	18	1-103669-7
9	1	43.69 [1.720]	45.59 [1.795]	16	17	1-103669-6
9	1	41.15 [1.620]	43.05 [1.695]	15	16	1-103669-5
11	9	38.61 [1.520]	40.51 [1.595]	14	15	1-103669-4
9	1	36.07 [1.420]	37.97 [1.495]	13	14	1-103669-3
9	1	33.53 [1.320]	35.43 [1.395]	12	13	1-103669-2
9	1	30.99 [1.220]	32.89 [1.295]	11	12	1-103669-1
9	1	28.45 [1.120]	30.35 [1.195]	10	11	1-103669-0
9	1	25.91 [1.020]	27.81 [1.095]	9	10	103669-9
9	1	23.37 [0.920]	25.27 [0.995]	8	9	103669-8
9	1	20.83 [0.820]	22.73 [0.895]	7	8	103669-7
9	1	18.29 [0.720]	20.19 [0.795]	6	7	103669-6
9	1	15.75 [0.620]	17.65 [0.695]	5	6	103669-5
9	1	13.21 [0.520]	15.11 [0.595]	4	5	103669-4
9	1	10.67 [0.420]	12.57 [0.495]	3	4	103669-3
9	1	8.13 [0.320]	10.03 [0.395]	2	3	103669-2
9	1	5.59 [0.220]	7.49 [0.295]	1	2	103669-1

THIS DRAWING IS A CONTROLLED DOCUMENT.

DTN: S. SHUEY 3-5-91  
 CDR: M. RIDER 2-14-92  
 APVD: M. RIDER 2-14-92

TE Connectivity

HDR ASSY, VERT, SINGLE ROW  
 2.54 [100] C/L 0.64 [025] SQ POST  
 WITH PLZN, AMPMODU MTE

108-25034  
 114-25026

SIZE: A1  
 WEIGHT: -  
 CUSTOMER DRAWING

SCALE: 4:1  
 SHEET: 1 OF 2  
 REV: AB

REVISIONS					
P	LYR	DESCRIPTION	DATE	DMN	APVD
-		SEE SHEET 1	-	-	-

OBSOLETE △11	△9/10	△8	64.01 [2.520]	65.91 [2.595]	24	25	7-103669-4
	△9/10	△8	61.47 [2.420]	63.37 [2.495]	23	24	7-103669-3
	△9/10	△8	58.93 [2.320]	60.83 [2.395]	22	23	7-103669-2
	△9/10	△8	56.39 [2.220]	58.29 [2.295]	21	22	7-103669-1
	△9/10	△8	53.85 [2.120]	55.75 [2.195]	20	21	7-103669-0
	△9/10	△8	51.31 [2.020]	53.21 [2.095]	19	20	6-103669-9
	△9/10	△8	48.77 [1.920]	50.67 [1.995]	18	19	6-103669-8
	△9/10	△8	46.23 [1.820]	48.13 [1.895]	17	18	6-103669-7
	△9/10	△8	43.69 [1.720]	45.59 [1.795]	16	17	6-103669-6
	△9/10	△8	41.15 [1.620]	43.05 [1.695]	15	16	6-103669-5
OBSOLETE △11	△9/10	△8	38.61 [1.520]	40.51 [1.595]	14	15	6-103669-4
	△9/10	△8	36.07 [1.420]	37.97 [1.495]	13	14	6-103669-3
	△9/10	△8	33.53 [1.320]	35.43 [1.395]	12	13	6-103669-2
	△9/10	△8	30.99 [1.220]	32.89 [1.295]	11	12	6-103669-1
	△9/10	△8	28.45 [1.120]	30.35 [1.195]	10	11	6-103669-0
	△9/10	△8	25.91 [1.020]	27.81 [1.095]	9	10	5-103669-9
	△9/10	△8	23.37 [.920]	25.27 [.995]	8	9	5-103669-8
	△9/10	△8	20.83 [.820]	22.73 [.895]	7	8	5-103669-7
	△9/10	△8	18.29 [.720]	20.19 [.795]	6	7	5-103669-6
	△9/10	△8	15.75 [.620]	17.65 [.695]	5	6	5-103669-5
	△9/10	△8	13.21 [.520]	15.11 [.595]	4	5	5-103669-4
	△9/10	△8	10.67 [.420]	12.57 [.495]	3	4	5-103669-3
	△9/10	△8	8.13 [.320]	10.03 [.395]	2	3	5-103669-2
	△9/10	△8	5.59 [.220]	7.49 [.295]	1	2	5-103669-1
REMARKS	PLATING	C	B	A	NO. OF POSN	PART NO.	

THIS DRAWING IS A CONTROLLED DOCUMENT.		DMN S. SHUEY 3-5-91	 TE Connectivity	
DIMENSIONS: INCHES		CHK M. RIDER 2-14-92	NAME	
TOLERANCES UNLESS OTHERWISE SPECIFIED:		APVD M. RIDER 2-14-92	HDR ASSY, VERT, SINGLE ROW	
0. PLC ± -	1. PLC ± -	PRODUCT SPEC	2.54 [.100] C/L 0.64 [.025] SQ POST	
2. PLC ± 0.13[.005]	3. PLC ± -	APPLICATION SPEC	WITH PLZN, AMPMODU MTE	
4. PLC ± -	ANGLES ± -	SIZE	CAGE CODE	DRAWING NO
MATERIAL HOUSING: LCP	FINISH SEE TABLE	114-25026	A1	00779
WEIGHT -		RESTRICTED TO	C=103669	
CUSTOMER DRAWING		SCALE 4:1	SHEET 2	OF 2



Компания «ЭлектроПласт» предлагает заключение долгосрочных отношений при поставках импортных электронных компонентов на взаимовыгодных условиях!

Наши преимущества:

- Оперативные поставки широкого спектра электронных компонентов отечественного и импортного производства напрямую от производителей и с крупнейших мировых складов;
- Поставка более 17-ти миллионов наименований электронных компонентов;
- Поставка сложных, дефицитных, либо снятых с производства позиций;
- Оперативные сроки поставки под заказ (от 5 рабочих дней);
- Экспресс доставка в любую точку России;
- Техническая поддержка проекта, помощь в подборе аналогов, поставка прототипов;
- Система менеджмента качества сертифицирована по Международному стандарту ISO 9001;
- Лицензия ФСБ на осуществление работ с использованием сведений, составляющих государственную тайну;
- Поставка специализированных компонентов (Xilinx, Altera, Analog Devices, Intersil, Interpoint, Microsemi, Aeroflex, Peregrine, Syfer, Eurofarad, Texas Instrument, Miteq, Cobham, E2V, MA-COM, Hittite, Mini-Circuits, General Dynamics и др.);

Помимо этого, одним из направлений компании «ЭлектроПласт» является направление «Источники питания». Мы предлагаем Вам помощь Конструкторского отдела:

- Подбор оптимального решения, техническое обоснование при выборе компонента;
- Подбор аналогов;
- Консультации по применению компонента;
- Поставка образцов и прототипов;
- Техническая поддержка проекта;
- Защита от снятия компонента с производства.



#### Как с нами связаться

**Телефон:** 8 (812) 309 58 32 (многоканальный)

**Факс:** 8 (812) 320-02-42

**Электронная почта:** [org@eplast1.ru](mailto:org@eplast1.ru)

**Адрес:** 198099, г. Санкт-Петербург, ул. Калинина, дом 2, корпус 4, литера А.