

Differential CATV Variable Gain Amplifier 50 - 1200 MHz

Rev. V2

Features

- 28 dB Gain
- 25 dB Attenuation Range
- -62 dBc ACPR @ 67 dBmV Output
-1 channel 256 QAM
- -60 dBc ACPR @ 59 dBmV/channel
-4 channel 256 QAM
- 6 V, 900 mA
- Differential Input and Output
- Low Harmonics
- Single Control Voltage
- Lead-Free 5 x 7 mm PQFN-40LD
- Halogen-Free “Green” Mold Compound
- RoHS* Compliant

Description

The MAAM-010399 is an integrated 3 stage differential amplifier with embedded voltage variable attenuator. This part is intended as the output amplifier in a downstream Edge QAM RF modulator. The module provides excellent linearity and ACPR at output levels greater than 7 dB above Cable Labs DRFI requirements. The voltage variable attenuator (VVA) is implemented with PIN diodes to provide continuous power level control with high linearity and is controlled with a single voltage. The part is packaged in a 5 x 7 mm PQFN package.

Ordering Information^{1,2}

Part Number	Package
MAAM-010399-TR1000	1000 piece reel
MAAM-010399-TR3000	3000 piece reel
MAAM-010399-001SMB	Sample Test Board

1. Reference Application Note M513 for reel size information.
2. All sample boards include 5 loose parts.

* Restrictions on Hazardous Substances, European Union Directive 2011/65/EU.

Functional Schematic

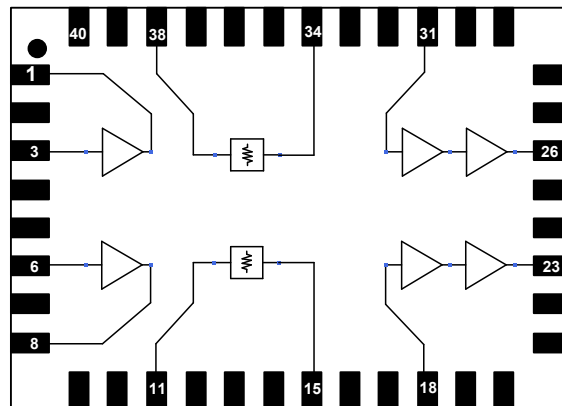

Pin Configuration^{3,4}

Pin No.	Pin Name	Description
1	RF _{OUT} 1+	Stage 1 Output (+)
2	FB1+	Stage 1 Feedback (+)
3	RF _{IN} +	Stage 1 Input (+)
5	IADJ1	Stage 1 Current Adjust
6	RF _{IN} 1-	Stage 1 Input (-)
7	FB1-	Stage 1 Feedback (-)
8	RF _{OUT} 1-	Stage 1 Output (-)
9,17,32,40	VREF	VVA reference voltage
11	VVA _{IN} -	VVA Input (-)
13,36	V _{CONTROL}	VVA Control Voltage
15	VVA _{OUT} -	VVA Output (-)
18	RF _{IN} 2-	Stage 2 Input (-)
19	FB2-	Stage 2 Feedback (-)
20	V _{DD} 2-	Stage 2 Drain Bias (-)
23	RF _{OUT} -	Output of VGA (-)
24	IADJ2	Stage 2 Current Adjust
25	IADJ3	Stage 3 Current Adjust
26	RF _{OUT} +	Output of VGA (+)
29	V _{DD} 2+	Stage 2 Drain Bias (+)
30	FB2+	Stage 2 Feedback (+)
31	RF _{IN} 2+	Stage 2 Input (+)
34	VVA _{OUT} +	VVA Output (+)
38	VVA _{IN} +	VVA Input (+)
41	Paddle	RF & DC Ground

3. Do not ground pins 10,12,14,16,33,35,37 and 39 (all are “No Connection”).
4. Pins 4, 21, 22, 27 and 28 may or may not be grounded (all are “No Connection”).

Differential CATV Variable Gain Amplifier 50 - 1200 MHz

Rev. V2

Electrical Specifications⁵: Freq. = 981 MHz, T_A = 25°C, V_{DD} = +6 Volts, V_{REF} = 1.3 Volts, Z₀ = 75 Ω, (Performance specified with input/output Balun MABA-010321-CT1A42)

Parameter	Test Conditions	Units	Min.	Typ.	Max.
Gain	VVA Control = 5.5 V	dB	26	28	—
Gain Flatness	—	dB	—	0.25	—
Gain Slope	—	dB	—	0.5	—
Noise Figure ⁶	200 - 1000 MHz, VVA Control = 5.5 V 50 - 200 MHz, VVA Control = 5.5 V	dB	—	5.0 6.5	—
Input Return Loss	—	dB	—	20	—
Output Return Loss	—	dB	—	20	—
Reverse Isolation	—	dB	—	60	—
Attenuation Range	—		—	25	—
Maximum Output	Level N = 1 Level N = 2 Level N = 4	dBmV	— — 57	67 63 59	—
ACPR ⁷	@ max output N = 1 @ max output N = 2 @ max output N = 4	dBc	—	—	-62 -60 -60
P1dB	—	dBm	—	28	—
OIP2	2-tone, 5 dBm/tone, 6 MHz spacing, 500 MHz	dBm	—	80	—
OIP3	2-tone, 5 dBm/tone, 6 MHz spacing, 500 MHz	dBm	—	48	—
CTB	77 Channels, 39 dBmV/ch.	dBc	—	-78	—
CSOL	77 Channels, 39 dBmV/ch.	dBc	—	-78	—
CSOH	77 Channels, 39 dBmV/ch.	dBc	—	-81	—
2 nd Harmonic	Single Channel, P _{OUT} = 67 dBmV	dBc	—	-65	—
3 rd Harmonic	Single Channel, P _{OUT} = 67 dBmV	dBc	—	-65	—
I _{DD}	—	mA	—	900	1050
I _{DD3}	—	mA	—	520	600
I _{CONTROL}	VVA Control = 5.5 V	mA	—	35	—

5. N = number of channels

6. Includes Balun Loss.

7. Adjacent Channel (750 kHz from channel block edge to 6 MHz from channel block edge)

Absolute Maximum Ratings ^{8,9,10}

Parameter	Absolute Maximum
RF Input Power	-2 dBm
Voltage	9 volts
Operating Temperature	-40°C to +100°C
Junction Temperature ¹¹	+155°C
Storage Temperature	-65°C to +150°C

8. Exceeding any one or combination of these limits may cause permanent damage to this device.
9. MACOM does not recommend sustained operation near these survivability limits.
10. Operating at nominal conditions with $T_J < 155^\circ\text{C}$ will ensure $\text{MTTF} > 1 \times 10^6$ hours.
11. Junction Temperature (T_J) = $T_C + \Theta_{JC} * (V * I)$
 Typical thermal resistance (Θ_{JC}) = 14.9°C/W .
- a) For $T_C = 25^\circ\text{C}$,
 $T_J = 63^\circ\text{C}$ @ 6 V, 420 mA (output stage)
- b) For $T_C = 100^\circ\text{C}$,
 $T_J = 138^\circ\text{C}$ @ 6 V, 420 mA (output stage)

Handling Procedures

Please observe the following precautions to avoid damage:

Static Sensitivity

Gallium Arsenide Integrated Circuits are sensitive to electrostatic discharge (ESD) and can be damaged by static electricity. Proper ESD control techniques should be used when handling these devices.

Recommended PCB

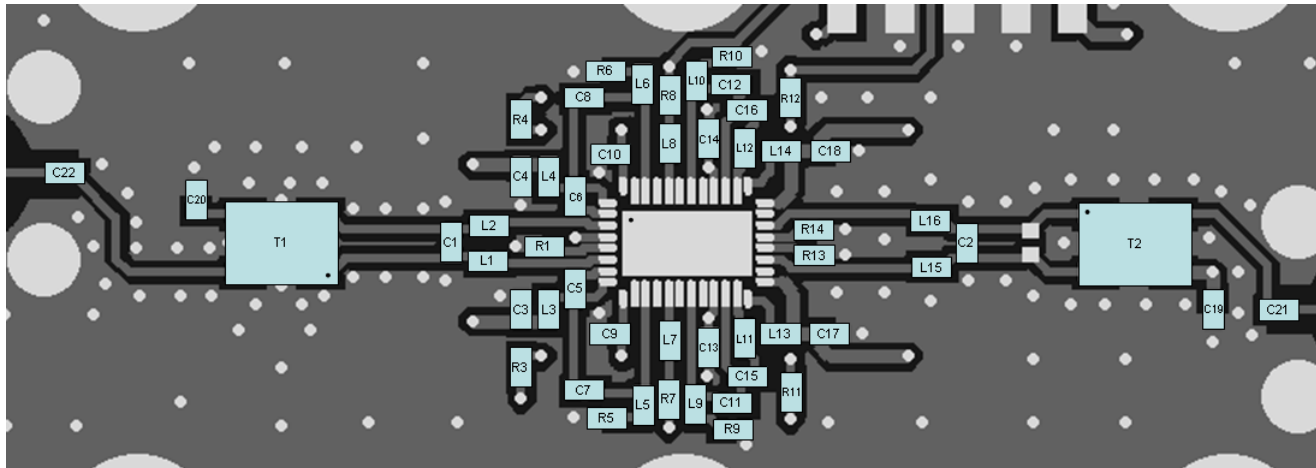

Parts List

Component	Value	Package
C1	0.5 pF	0402
C2	1.8 pF	0402
C3, C4, C9, C10, C13, C14, C17 - C22	0.01 μ F	0402
C5 - C8, C11, C12, C15, C16	1000 pF	0402
L1, L2, L15, L16	0 Ω	0402
L3 - L8, L13 - L14 ¹²	1 k Ω	0402
L9, L10	68 nH	0402
L11, L12	12 nH	0402
R1	50 Ω	0402
R2	330 Ω	0402
R3 - R6, R9 - R12	200 Ω	0402
R7, R8, R13	150 Ω	0402
R14	82 Ω	0402
R15	1 k Ω	0402
T1, T2	1:1 Baluns (MACOM part # MABA-010321-CT1A42)	

12. The 1 k Ω ferrite bead (part number BLM15HD102SN) is from Murata.

Differential CATV Variable Gain Amplifier 50 - 1200 MHz

Rev. V2

Application Schematic

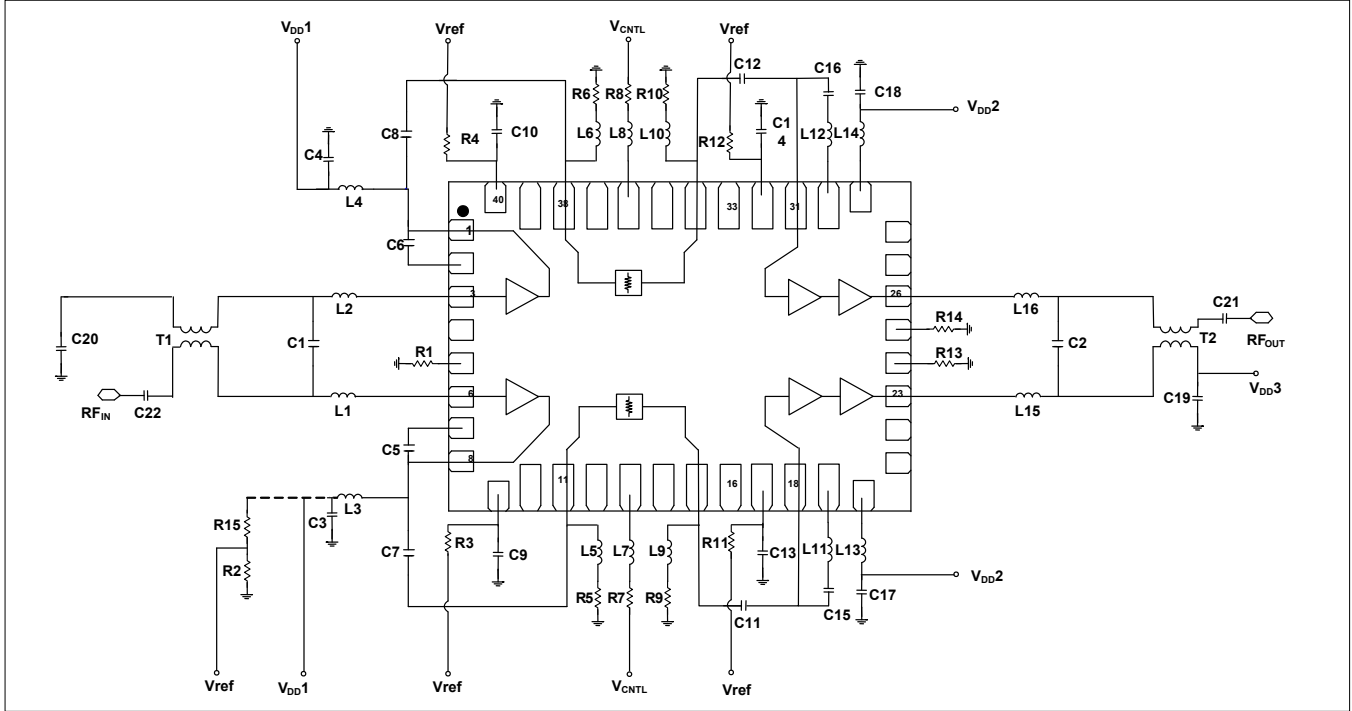

Land Pattern¹³

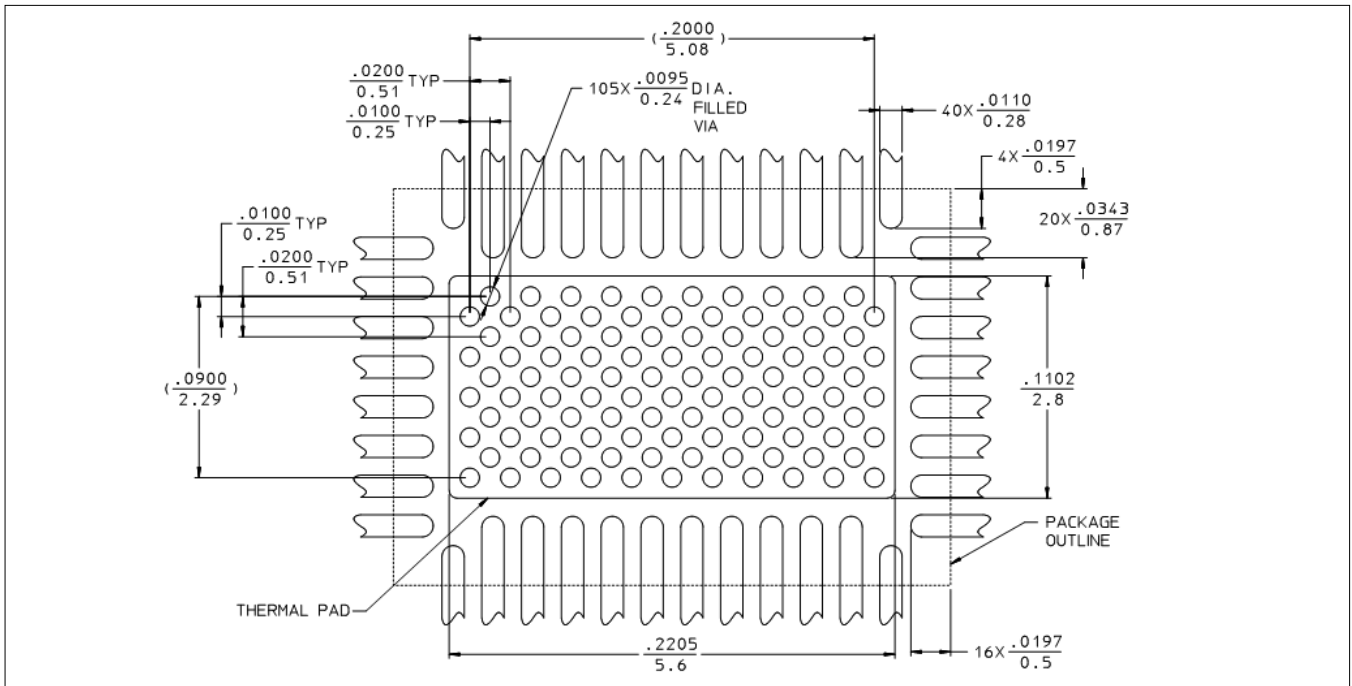

13. Vias to be plated solid copper.

Differential CATV Variable Gain Amplifier 50 - 1200 MHz

Rev. V2

Typical Performance Curves: $V_{DD} = +6$ Volts, $V_{REF} = 1.3$ Volts

Gain vs. Frequency & VGA Control

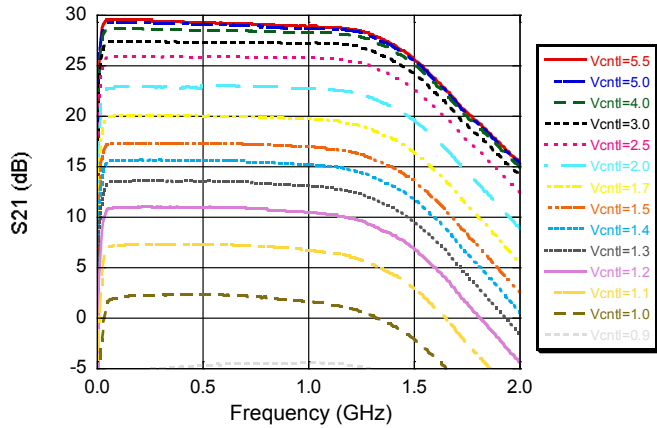

Input Return Loss vs. Frequency & VGA Control

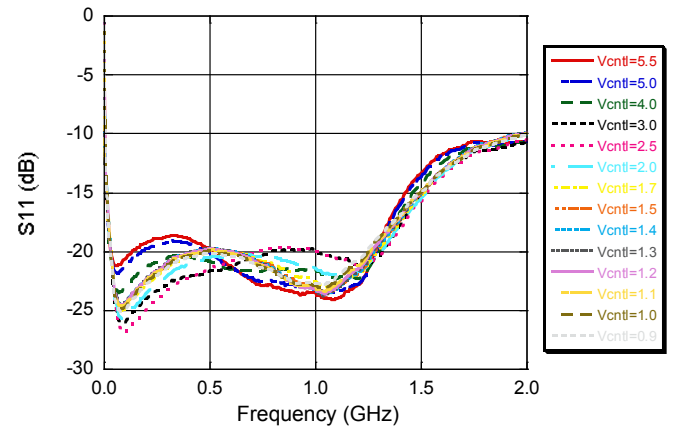

Output Return Loss vs. Frequency & VGA Control

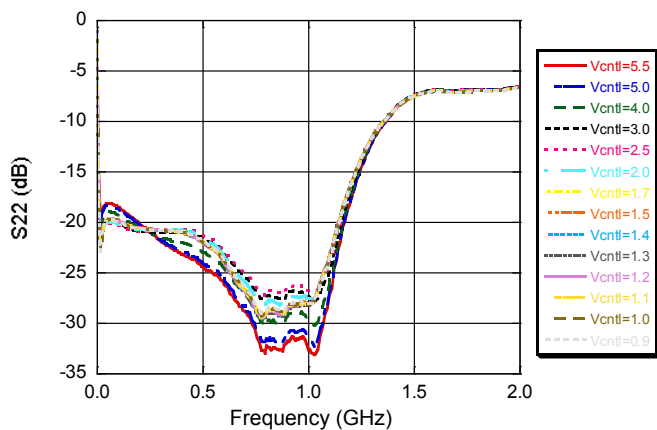

Reverse Isolation

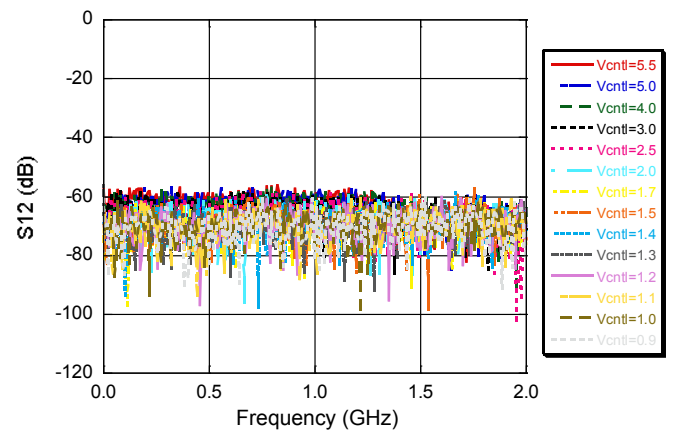

Gain vs. VVA Control @ 500 MHz

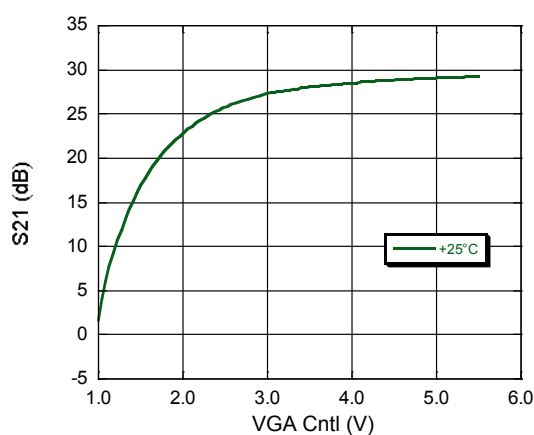

Noise Figure

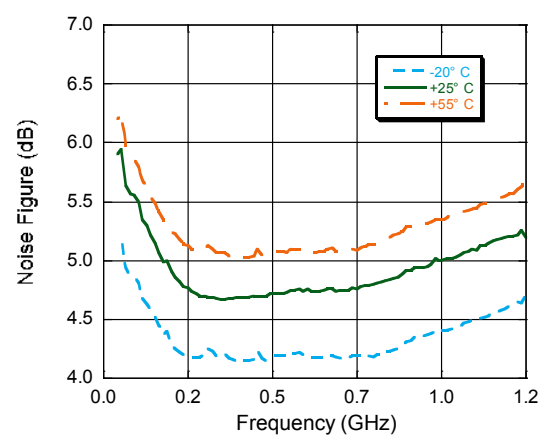

Differential CATV Variable Gain Amplifier 50 - 1200 MHz

Rev. V2

Typical Performance Curves: $V_{DD} = +6$ Volts, $V_{REF} = 1.3$ Volts

ACPR vs. P_{OUT} , 4 Channels

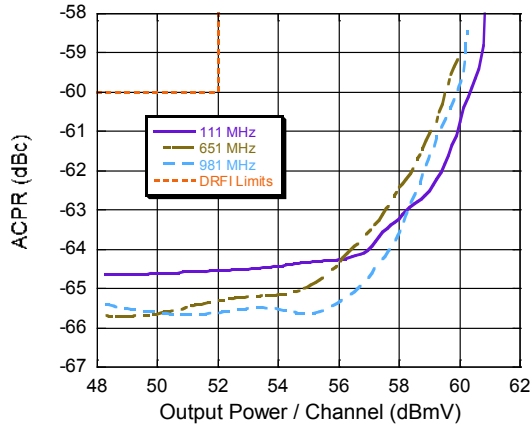

ACPR vs. P_{OUT} , Single Channel

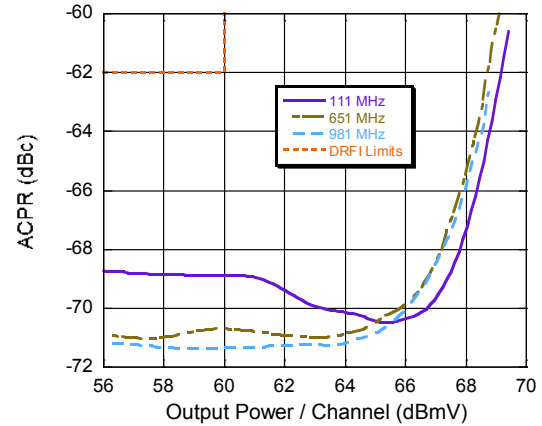

Lead-Free 5 x 7 mm 40-Lead PQFN†

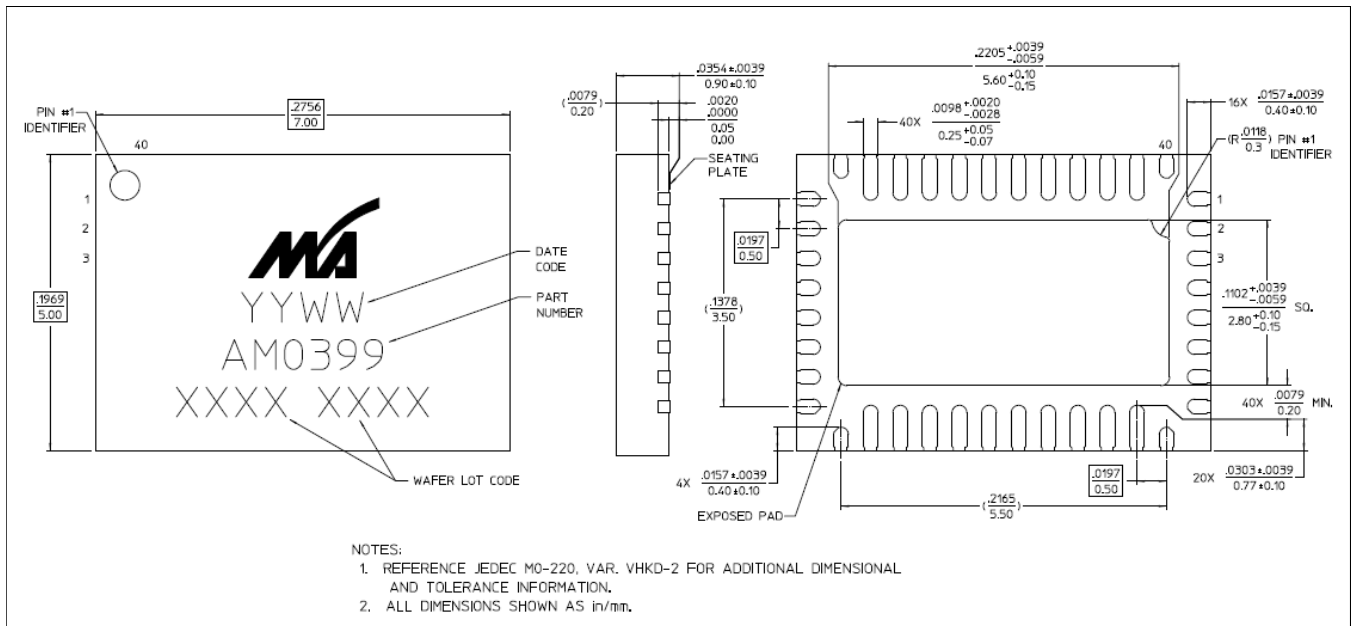

† Reference Application Note S2083 for lead-free solder reflow recommendations.
 Meets JEDEC moisture sensitivity level 1 requirements.
 Plating is NiPdAuAg.

Applications Section - 1200 MHz

By using L1 and L2 = 15 nH, the MAAM-010399 may be operated up to 1200 MHz

Typical Performance Curves: $V_{DD} = 6$ Volts, $V_{REF} = 1.3$ Volts

Gain vs. Frequency & VGA Control

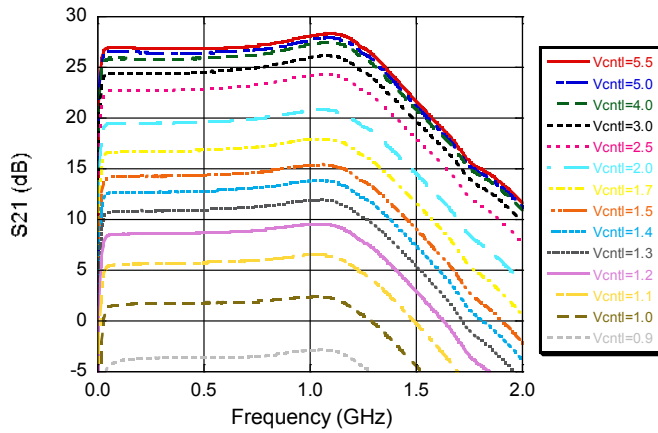

Input Return Loss vs. Frequency & VGA Control

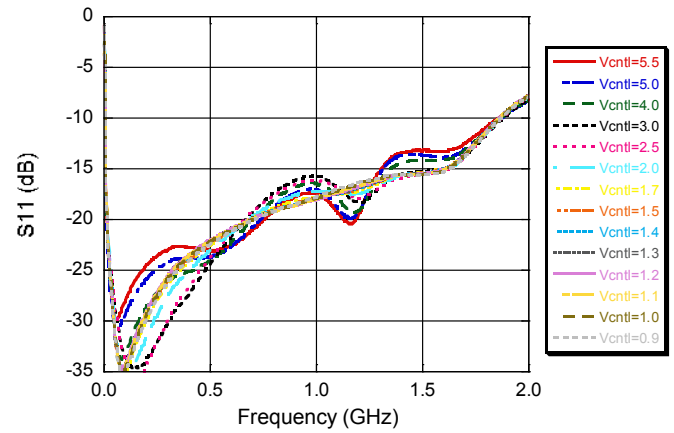

Output Return Loss vs. Frequency & VGA Control

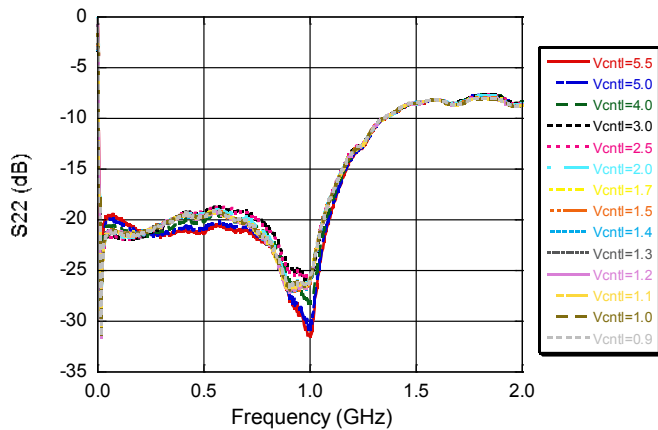

Reverse Isolation

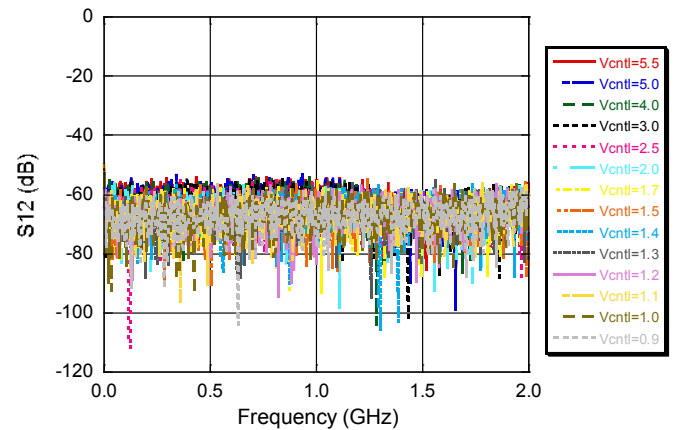

M/A-COM Technology Solutions Inc. All rights reserved.

Information in this document is provided in connection with M/A-COM Technology Solutions Inc ("MACOM") products. These materials are provided by MACOM as a service to its customers and may be used for informational purposes only. Except as provided in MACOM's Terms and Conditions of Sale for such products or in any separate agreement related to this document, MACOM assumes no liability whatsoever. MACOM assumes no responsibility for errors or omissions in these materials. MACOM may make changes to specifications and product descriptions at any time, without notice. MACOM makes no commitment to update the information and shall have no responsibility whatsoever for conflicts or incompatibilities arising from future changes to its specifications and product descriptions. No license, express or implied, by estoppel or otherwise, to any intellectual property rights is granted by this document.

THESE MATERIALS ARE PROVIDED "AS IS" WITHOUT WARRANTY OF ANY KIND, EITHER EXPRESS OR IMPLIED, RELATING TO SALE AND/OR USE OF MACOM PRODUCTS INCLUDING LIABILITY OR WARRANTIES RELATING TO FITNESS FOR A PARTICULAR PURPOSE, CONSEQUENTIAL OR INCIDENTAL DAMAGES, MERCHANTABILITY, OR INFRINGEMENT OF ANY PATENT, COPYRIGHT OR OTHER INTELLECTUAL PROPERTY RIGHT. MACOM FURTHER DOES NOT WARRANT THE ACCURACY OR COMPLETENESS OF THE INFORMATION, TEXT, GRAPHICS OR OTHER ITEMS CONTAINED WITHIN THESE MATERIALS. MACOM SHALL NOT BE LIABLE FOR ANY SPECIAL, INDIRECT, INCIDENTAL, OR CONSEQUENTIAL DAMAGES, INCLUDING WITHOUT LIMITATION, LOST REVENUES OR LOST PROFITS, WHICH MAY RESULT FROM THE USE OF THESE MATERIALS.

MACOM products are not intended for use in medical, lifesaving or life sustaining applications. MACOM customers using or selling MACOM products for use in such applications do so at their own risk and agree to fully indemnify MACOM for any damages resulting from such improper use or sale.



Компания «ЭлектроПласт» предлагает заключение долгосрочных отношений при поставках импортных электронных компонентов на взаимовыгодных условиях!

Наши преимущества:

- Оперативные поставки широкого спектра электронных компонентов отечественного и импортного производства напрямую от производителей и с крупнейших мировых складов;
- Поставка более 17-ти миллионов наименований электронных компонентов;
- Поставка сложных, дефицитных, либо снятых с производства позиций;
- Оперативные сроки поставки под заказ (от 5 рабочих дней);
- Экспресс доставка в любую точку России;
- Техническая поддержка проекта, помощь в подборе аналогов, поставка прототипов;
- Система менеджмента качества сертифицирована по Международному стандарту ISO 9001;
- Лицензия ФСБ на осуществление работ с использованием сведений, составляющих государственную тайну;
- Поставка специализированных компонентов (Xilinx, Altera, Analog Devices, Intersil, Interpoint, Microsemi, Aeroflex, Peregrine, Syfer, Eurofarad, Texas Instrument, Miteq, Cobham, E2V, MA-COM, Hittite, Mini-Circuits, General Dynamics и др.);

Помимо этого, одним из направлений компании «ЭлектроПласт» является направление «Источники питания». Мы предлагаем Вам помощь Конструкторского отдела:

- Подбор оптимального решения, техническое обоснование при выборе компонента;
- Подбор аналогов;
- Консультации по применению компонента;
- Поставка образцов и прототипов;
- Техническая поддержка проекта;
- Защита от снятия компонента с производства.



Как с нами связаться

Телефон: 8 (812) 309 58 32 (многоканальный)

Факс: 8 (812) 320-02-42

Электронная почта: org@eplast1.ru

Адрес: 198099, г. Санкт-Петербург, ул. Калинина, дом 2, корпус 4, литера А.