

Low Noise, High Frequency, 8th Order Linear Phase Lowpass Filter

FEATURES

- 8th Order Filter in a 14-Pin Package
- 95kHz Maximum Corner Frequency
- No External Components
- 75:1, 150:1 and 120:1 Clock to Cutoff Frequency Ratio
- $60\mu\text{V}_{\text{RMS}}$ Total Wideband Noise
- 0.03% THD or Better
- Operates from $\pm 2.37\text{V}$ to $\pm 8\text{V}$ Power Supplies
- Low Total Output DC Offset

APPLICATIONS

- Antialiasing Filters
- Smoothing Filters
- Tracking High Frequency Lowpass Filters

DESCRIPTION

The LTC[®]1064-3 is a monolithic 8th order lowpass Bessel filter, which provides a linear phase response over its entire passband. An external TTL or CMOS clock programs the filter's cutoff frequency. The clock to cutoff frequency ratio is 75:1 (Pin 10 at V⁺) or 150:1 (Pin 10 at V⁻) or 120:1 (Pin 10 at GND). The maximum cutoff frequency is 95kHz. No external components are needed.

The LTC1064-3 features low wideband noise and low harmonic distortion even for input voltages up to 3V_{RMS} . In fact the LTC1064-3 overall performance competes with equivalent multiple op amp RC active realizations. The LTC1064-3 is available in a 14-pin DIP or 16-pin surface mounted SOL package. The LTC1064-3 is fabricated using LTC's enhanced analog CMOS Si-gate process.

The LTC1064-3 is pin compatible with the LTC1064-1, LTC1064-2 and LTC1064-4.

 LTC and LT are registered trademarks of Linear Technology Corporation.

TYPICAL APPLICATION

8th Order Clock Sweepable Lowpass Bessel Filter

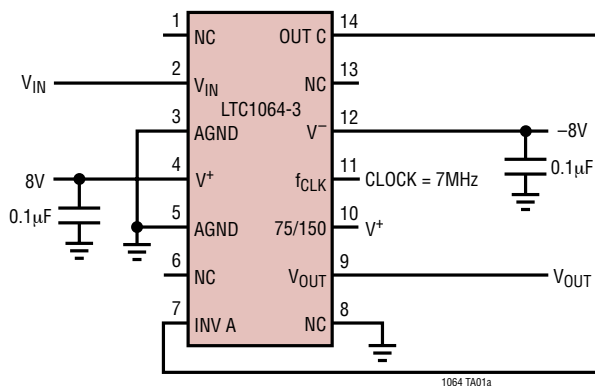

NOTE: THE POWER SUPPLIES SHOULD BE BYPASSED BY A $0.1\mu\text{F}$ OR LARGER CAPACITOR CLOSE TO THE PACKAGE. THE CONNECTION BETWEEN PIN 7 AND PIN 14 SHOULD BE MADE UNDER THE IC PACKAGE.

Measured Frequency Response

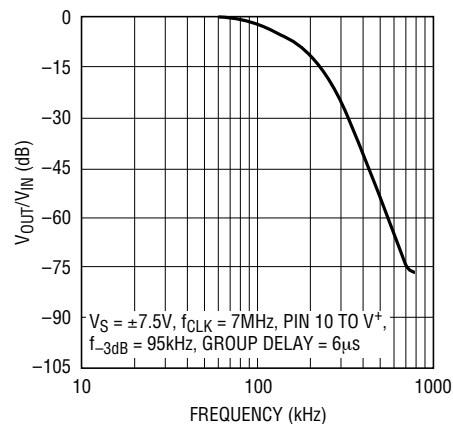

1064-3 TA01b

LTC1064-3

ABSOLUTE MAXIMUM RATINGS (Note 1)

Total Supply Voltage (V^+ to V^-)	16.5V	Operating Temperature Range	
Power Dissipation	400mW	LTC1064-3M (OBSOLETE)	-55°C to 125°C
Storage Temperature Range	-65°C to 150°C	LTC1064-3C	-40°C to 85°C
Lead Temperature (Soldering, 10 sec)	300°C	Input Voltage	(V^+ +0.3V) to V^- -0.3V)
		Burn-In Voltage	15V

PACKAGE/ORDER INFORMATION

<p>N PACKAGE 14-LEAD PDIP $T_{JMAX} = 110^\circ\text{C}$, $\theta_{JA} = 70^\circ\text{C/W}$</p>	<p>ORDER PART NUMBER</p> <p>LTC1064-3CN</p>	<p>SW PACKAGE 16-LEAD PLASTIC (WIDE) SO $T_{JMAX} = 150^\circ\text{C}$, $\theta_{JA} = 90^\circ\text{C/W}$</p>	<p>ORDER PART NUMBER</p> <p>LTC1064-3CSW</p>
<p>J PACKAGE 14-LEAD CERDIP</p> <p>OBSOLETE PACKAGE Consider the N 14 Package for Alternate Source</p>	<p>LTC1064-3MJ LTC1064-3CJ</p>		

Consult LTC Marketing for parts specified with wider operating temperature ranges.

ELECTRICAL CHARACTERISTICS

The ● denotes the specifications which apply over the full operating temperature range, otherwise specifications are at $T_A = 25^\circ\text{C}$. $V_S = \pm 7.5\text{V}$, 75:1, $f_{CLK} = 2\text{MHz}$, $R_1 = 10\text{k}$, TTL or CMOS clock input level unless otherwise specified.

PARAMETER	CONDITIONS	MIN	TYP	MAX	UNITS
Passband Gain	Referenced to 0dB, 1Hz to 1kHz	● -0.5		0.15	dB
Gain TempCo			0.0002		dB/°C
-3dB Frequency	50:1 ($f_{CLK}/f_{-3dB} = 75$)		26.67		kHz
	100:1 ($f_{CLK}/f_{-3dB} = 150$)		13.34		kHz
Gain at -3dB Frequency	Referenced to 0dB, $f_{IN} = 26.67/13.34\text{kHz}$	● -3.8		-2.75	dB
Stopband Attenuation	At $3f_{-3dB}$	● -25	-29		dB
Stopband Attenuation	At $5f_{-3dB}$	● -56	-60		dB
Stopband Attenuation	At $7f_{-3dB}$		-84		dB
Input Frequency Range	100:1	0		$<f_{CLK}/2$	kHz
	50:1	0		$<f_{CLK}$	kHz
Output Voltage Swing and Operating Input Voltage Range	$V_S = \pm 2.37\text{V}$	● ± 1.1			V
	$V_S = \pm 5\text{V}$	● ± 3.1			V
	$V_S = \pm 7.5\text{V}$	● ± 5			V
Total Harmonic Distortion	$V_S = \pm 5\text{V}$, Input = $1V_{RMS}$ at 1kHz		0.015		%
	$V_S = \pm 7.5\text{V}$, Input = $3V_{RMS}$ at 1kHz		0.03		%
Wideband Noise	$V_S = \pm 5\text{V}$, Input = GND 1Hz - 1.99MHz		55		μV_{RMS}
	$V_S = \pm 7.5\text{V}$, Input = GND 1Hz - 1.99MHz		60		μV_{RMS}

10643fa

ELECTRICAL CHARACTERISTICS The ● denotes the specifications which apply over the full operating temperature range, otherwise specifications are at $T_A = 25^\circ\text{C}$. $V_S = \pm 7.5\text{V}$, 75:1, $f_{\text{CLK}} = 2\text{MHz}$, $R_1 = 10\text{k}$, TTL or CMOS clock input level unless otherwise specified.

PARAMETER	CONDITIONS	MIN	TYP	MAX	UNITS
Output DC Offset	$V_S = \pm 7.5\text{V}$		± 30	± 150	mV
Output DC Offset TempCo	$V_S = \pm 5\text{V}$ $V_S = \pm 7.5\text{V}$		± 20 ± 50		$\mu\text{V}/^\circ\text{C}$ $\mu\text{V}/^\circ\text{C}$
Input Impedance		14	22		$\text{k}\Omega$
Output Impedance	$f_{\text{OUT}} = 10\text{kHz}$		2		Ω
Output Short-Circuit Current	Source/Sink		3/1		mA
Clock Feedthrough			200		μV_{RMS}
Maximum Clock Frequency	$V_S \geq \pm 7\text{V}$, 50% Duty Cycle $V_S \geq \pm 7\text{V}$, 50% Duty Cycle, $T_A < 55^\circ\text{C}$			5 7	MHz MHz
Power Supply Current	$V_S = \pm 2.37\text{V}$, $f_{\text{CLK}} = 1\text{MHz}$ $V_S = \pm 5\text{V}$, $f_{\text{CLK}} = 1\text{MHz}$ $V_S = \pm 7.5\text{V}$, $f_{\text{CLK}} = 1\text{MHz}$	● ● ●	10 12 16	22 23 26 28	mA mA mA mA
Power Supply Voltage Range		●	± 2.37	± 8	V

Note 1: Absolute Maximum Ratings are those values beyond which the life of a device may be impaired.

TYPICAL PERFORMANCE CHARACTERISTICS

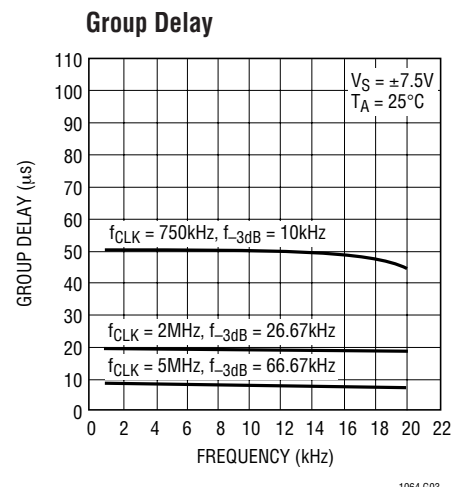
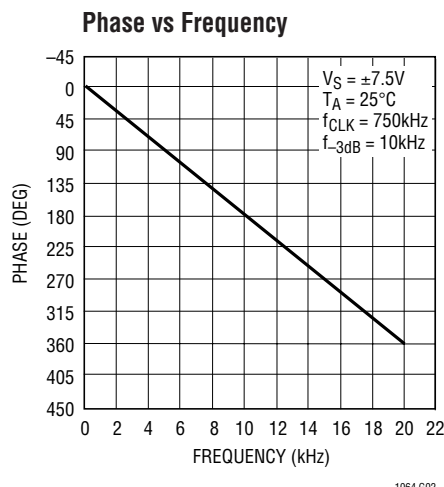
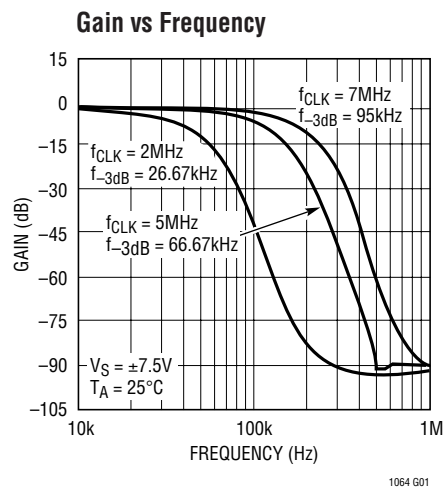

TYPICAL PERFORMANCE CHARACTERISTICS

Phase Matching

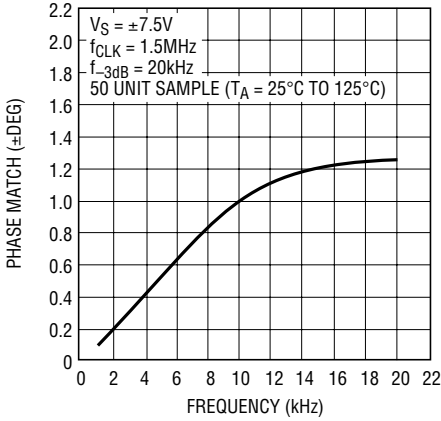

1064 G04

Total Harmonic Distortion

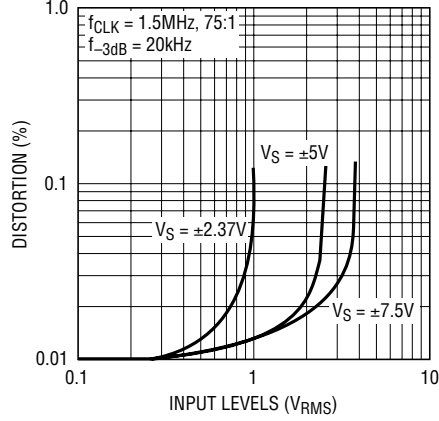

1064 G05

Power Supply Current vs Power Supply Voltage

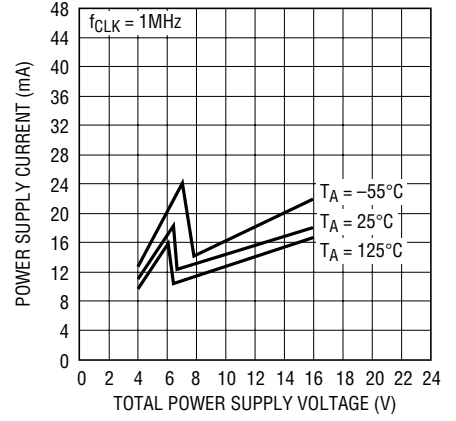

1064 G06

Transient Response
Input 10V_{P-P} Square Wave
 $V_S = \pm 7.5V$, Pin 10 to V^+ ,
 $f_{CLK} = 1.5MHz$

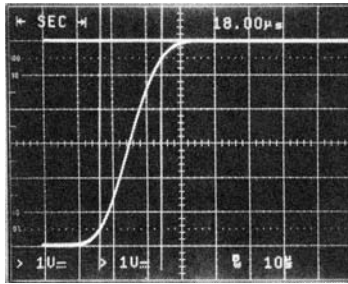

Table 1. Wideband Noise (μV_{RMS})

		$V_S = \pm 2.37V$	$V_S = \pm 5V$	$V_S = \pm 7.5V$
Pin 10 to	f_{CLK}/f_{-3dB}	Noise μV_{RMS}	Noise μV_{RMS}	Noise μV_{RMS}
V^+	75/1	50	55	60
V^-	150/1	52	58	62
GND	120/1	45	50	54

TYPICAL PERFORMANCE CHARACTERISTICS

Table 2. Gain/Phase, $f_{-3dB} = 1\text{kHz}$, LTC1064-3 Typical Response
 $V_S = \pm 5\text{V}$, $T_A = 25^\circ\text{C}$, $f_{CLK} = 75\text{kHz}$, Pin 10 at V^+ (fltr 75:1)

FREQUENCY (kHz)	GAIN (dB)	PHASE (deg)
0.500	-0.858	-90.430
1.000	-2.990	179.200
1.500	-6.840	89.600
2.000	-12.780	3.800
2.500	-20.800	-71.000
3.000	-29.900	-129.600
3.500	-38.800	-173.700
4.000	-47.100	152.600
4.500	-54.700	126.000
5.000	-61.600	103.300
5.500	-68.000	85.190
6.000	-73.840	69.060
6.500	-79.250	54.780
7.000	-84.230	42.440
7.500	-88.940	30.060
8.000	-93.360	21.300
8.500	-97.510	10.000
9.000	-100.880	1.520
9.500	-105.780	-7.820

Table 4. Gain/Phase, $f_{-3dB} = 1\text{kHz}$, LTC1064-3 Typical Response
 $V_S = \pm 5\text{V}$, $T_A = 25^\circ\text{C}$, $f_{CLK} = 150\text{kHz}$, Pin 10 at V^- (fltr 150:1)

FREQUENCY (kHz)	GAIN (dB)	PHASE (deg)
0.500	-0.955	-88.100
1.000	-3.380	-175.300
1.500	-7.570	99.700
2.000	-13.770	20.100
2.500	-21.800	-48.000
3.000	-30.700	-100.700
3.500	-39.400	-139.900
4.000	-47.600	-169.200
4.500	-55.100	168.300
5.000	-61.900	150.300
5.500	-68.260	135.830
6.000	-74.050	123.660
6.500	-79.450	113.440
7.000	-84.330	104.440
7.500	-89.010	97.670
8.000	-93.250	91.580
8.500	-97.340	84.670
9.000	-101.390	74.600
9.500	-104.980	75.990

Table 3. Gain/Delay, $f_{-3dB} = 1\text{kHz}$, LTC1064-3 Typical Response
 $V_S = \pm 5\text{V}$, $T_A = 25^\circ\text{C}$, $f_{CLK} = 75\text{kHz}$, Pin 10 at V^+ (fltr 75:1)

FREQUENCY (kHz)	GAIN (dB)	DELAY (ms)
0.200	-0.281	0.502
0.300	-0.420	0.503
0.400	-0.610	0.503
0.500	-0.860	0.502
0.600	-1.160	0.502
0.700	-1.530	0.502
0.800	-1.950	0.503
0.900	-2.430	0.503
1.000	-2.990	0.500
1.100	-3.610	0.500
1.200	-4.300	0.500
1.300	-5.060	0.498
1.400	-5.920	0.495
1.500	-6.830	0.491
1.600	-7.840	0.489
1.700	-8.930	0.481
1.800	-10.130	0.473
1.900	-11.410	0.465
2.000	-12.780	0.454

Table 5. Gain/Delay, $f_{-3dB} = 1\text{kHz}$, LTC1064-3 Typical Response
 $V_S = \pm 5\text{V}$, $T_A = 25^\circ\text{C}$, $f_{CLK} = 150\text{kHz}$, Pin 10 at V^- (fltr 150:1)

FREQUENCY	GAIN (dB)	DELAY (ms)
0.200	-0.284	0.490
0.300	-0.450	0.489
0.400	-0.670	0.489
0.500	-0.960	0.487
0.600	-1.310	0.487
0.700	-1.730	0.485
0.800	-2.210	0.484
0.900	-2.750	0.482
1.000	-3.380	0.478
1.100	-4.070	0.478
1.200	-4.820	0.475
1.300	-5.660	0.470
1.400	-6.580	0.467
1.500	-7.570	0.463
1.600	-8.640	0.456
1.700	-9.790	0.448
1.800	-11.050	0.438
1.900	-12.360	0.428
2.000	-13.770	0.417

TYPICAL PERFORMANCE CHARACTERISTICS

Table 6. Gain/Phase, $f_{-3dB} = 1\text{kHz}$, LTC1064-3 Typical Response
 $V_S = \pm 5\text{V}$, $T_A = 25^\circ\text{C}$, $f_{CLK} = 120\text{kHz}$, Pin 10 at GND (fltr 120:1)

FREQUENCY (kHz)	GAIN (dB)	PHASE (deg)
0.500	-0.994d	-82.210
1.000	-3.050	-162.800
1.500	-6.520	116.700
2.000	-12.180	40.200
2.500	-19.460	-23.600
3.000	-27.200	-74.000
3.500	-34.700	-114.200
4.000	-41.900	-146.800
4.500	-48.700	-173.300
5.000	-55.100	164.700
5.500	-60.900	145.800
6.000	-66.500	130.610
6.500	-71.660	117.130
7.000	-76.390	105.880
7.500	-80.910	96.140
8.000	-84.900	87.510
8.500	-88.750	81.380
9.000	-92.410	78.190
9.500	-98.290	52.860

Table 7. Gain/Delay, $f_{-3dB} = 1\text{kHz}$, LTC1064-3 Typical Response
 $V_S = \pm 5\text{V}$, $T_A = 25^\circ\text{C}$, $f_{CLK} = 120\text{kHz}$, Pin 10 at GND (fltr 120:1)

FREQUENCY (kHz)	GAIN (dB)	DELAY (ms)
0.200	-0.354	0.458
0.300	-0.520	0.456
0.400	-0.730	0.454
0.500	-1.000	0.452
0.600	-1.320	0.449
0.700	-1.670	0.448
0.800	-2.090	0.446
0.900	-2.540	0.446
1.000	-3.050	0.445
1.100	-3.600	0.446
1.200	-4.220	0.449
1.300	-4.900	0.448
1.400	-5.670	0.447
1.500	-6.520	0.446
1.600	-7.470	0.441
1.700	-8.500	0.432
1.800	-9.650	0.422
1.900	-10.870	0.409
2.000	-12.180	0.395

Table 8. Gain/Phase, $f_{-3dB} = 20\text{kHz}$, LTC1064-3 Typical Response
 $V_S = \pm 7.5\text{V}$, $f_{CLK} = 1.5\text{MHz}$, Pin 10 at V^+ (fltr 75:1)

$T_A = 25^\circ\text{C}$		
FREQUENCY (kHz)	GAIN (dB)	PHASE (deg)
10.000	-0.912	-92.270
20.000	-3.090	176.000
30.000	-6.910	85.500
40.000	-12.710	-1.200
50.000	-20.500	-77.800
60.000	-29.400	-138.700
70.000	-38.300	174.600
80.000	-46.500	138.300
90.000	-54.000	109.100
100.000	-61.000	84.800
110.000	-67.310	64.040
120.000	-73.170	46.260
130.000	-78.600	31.120
140.000	-83.760	18.050
150.000	-88.630	7.770

$T_A = 125^\circ\text{C}$		
FREQUENCY (kHz)	GAIN (dB)	PHASE (deg)
10.000	-0.944	-92.880
20.000	-3.170	175.500
30.000	-6.910	85.700
40.000	-12.450	-0.600
50.000	-19.920	-78.000
60.000	-28.500	-140.700
70.000	-37.200	170.500
80.000	-45.300	132.200
90.000	-52.700	100.900
100.000	-59.600	74.900
110.000	-65.900	52.600
120.000	-71.750	32.850
130.000	-77.170	15.840
140.000	-82.370	1.130
150.000	-87.400	-11.380

PIN FUNCTIONS (Pin Numbers Refer to the 14-Pin Package)

NC (Pins 1, 6, 8 and 13): The “no connection” pins should be preferably grounded. These pins are not internally connected.

V_{IN}, V_{OUT} (Pins 2, 9): The input Pin 2 is connected to an 18k resistor tied to the inverting input of an op amp. Pin 2 is protected against static discharge. The device’s output, Pin 9, is the output of an op amp which can typically source/sink 3mA/1mA. Although the internal op amps are unity gain stable, driving long coax cables is not recommended.

When testing the device for noise and distortion, the output, Pin 9, should be buffered (Figure 1). *The op amp power supply wire (or trace) should be connected directly to the power source. To eliminate switching transients from filter output, buffer filter output with a third order lowpass (see Figure 5).*

AGND (Pins 3, 5): For dual supply operation these pins should be connected to a ground plane. For single supply operation both pins should be tied to one half supply (Figure 3).

V⁺, V⁻ (Pins 4, 12): Should be bypassed with a 0.1μF capacitor to an adequate analog ground. Low noise, nonswitching power supplies are recommended. *To avoid latchup when the power supplies exhibit high turn-on transients, a 1N5817 Schottky diode should be added from the V⁺ and V⁻ pins to ground (Figure 1, 2 and 3).*

R_{IN A}, OUT C (Pins 7, 14): A very short connection between Pin 7 and Pin 14 is recommended. This connection should be preferably done under the IC package. In a breadboard, use a one inch, or less, shielded coaxial cable: the shield should be grounded. In a PC board, use a one inch trace or less; surround the trace by a ground plane.

50/100 (Pin 10): Ratio Pin. The DC level at this pin determines the ratio of clock frequency to the -3dB frequency of the filter. The ratio is 75:1 when Pin 10 is at V⁺, 120:1 when Pin 10 is at GND and 150:1 when Pin 10 is at V⁻. This pin should be bypassed with a 0.1μF capacitor to analog ground when it’s connected to V⁻ or V⁺ (Figure 1). See Tables 2 through 8 for typical gain and delay responses for the three ratios.

f_{CLK} (Pin 11): For ±5V supplies the logic threshold level is 1.4V. For ±8V and 0V to 5V supplies the logic threshold levels are 2.2V and 3V respectively. The logic threshold levels vary ±100mV over the full military temperature range. The recommended duty cycle of the input clock is 50% although for clock frequencies below 500kHz the clock “on” time can be as low as 200ns. The maximum clock frequency for ±5V supplies is 4MHz. For ±7V supplies and above, the maximum clock frequency is 7MHz. Do not allow the clock levels to exceed the power supplies. For single supply operation ≥6V use level shifting at Pin 11 with T²L levels (see Figure 4).

TYPICAL APPLICATIONS



Figure 1. Buffering the Filter Output. The Buffer Op Amp Should Not Share the LTC1064-3 Power Lines

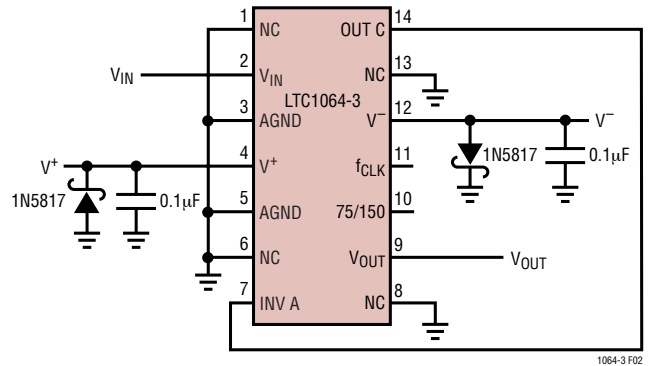

Figure 2. Using Schottky Diodes to Protect the IC from Power Supply Reversal



Figure 3. Single Supply Operation. If Fast Power Up or Down Transients are Expected, Use a 1N5817 Schottky Diode Between Pin 4 and Pin 5

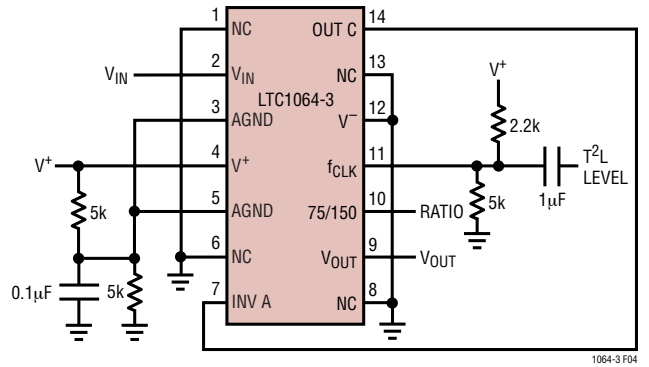

Figure 4. Level Shifting the Input T²L Clock for Single Supply Operation $\geq 6V$

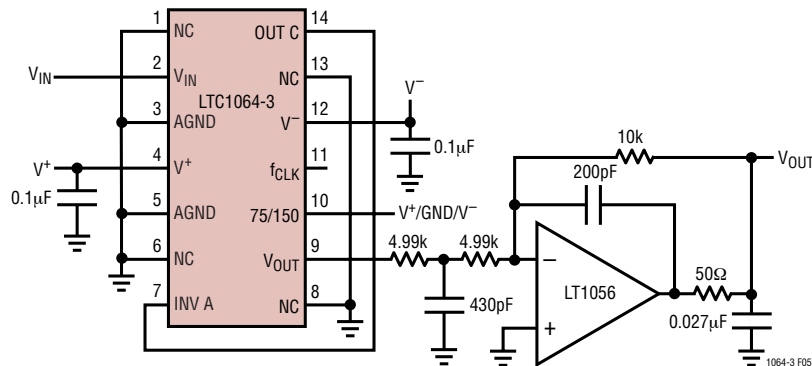
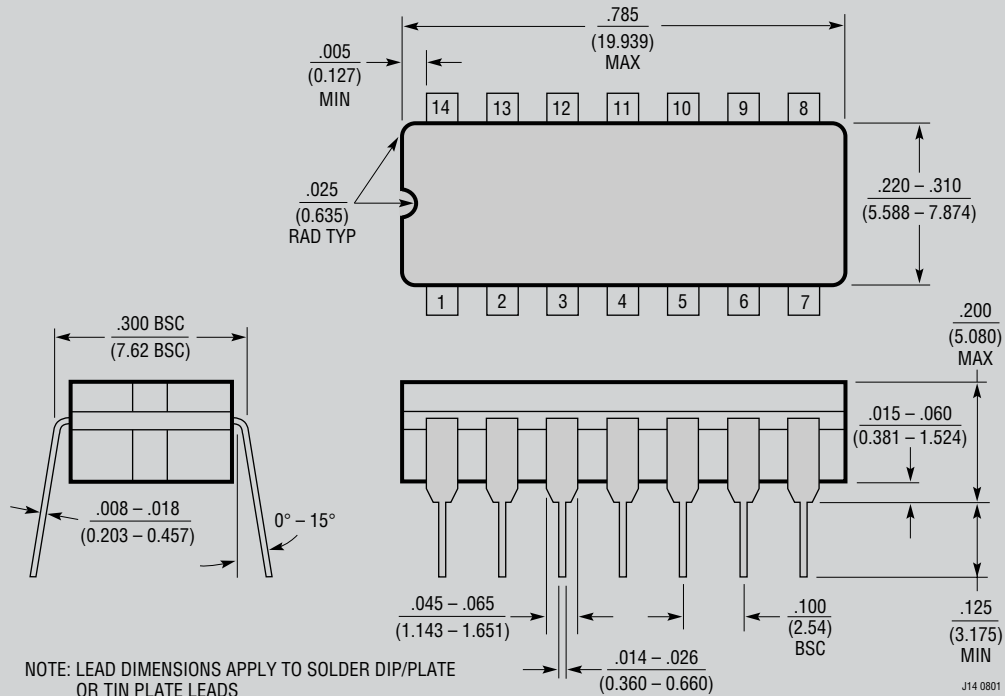

Figure 5. Adding an Output Buffer-Filter to Eliminate Any Clock Feedthrough. Passband $\pm 0.1\text{dB}$ to 50kHz, -3dB at 94kHz

PACKAGE DESCRIPTION

J Package
14-Lead CERDIP (Narrow 0.300, Hermetic)
 (LTC DWG # 05-08-1110)



OBsolete PACKAGE

PACKAGE DESCRIPTION

N Package
14-Lead PDIP (Narrow 0.300)
 (LTC DWG # 05-08-1510)

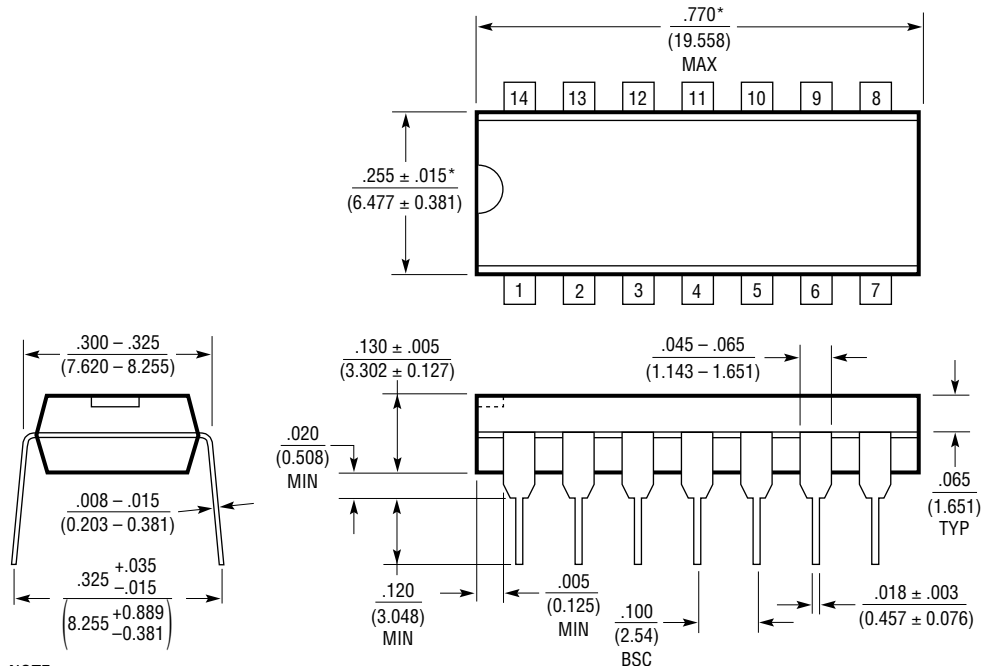

NOTE:
 1. DIMENSIONS ARE $\frac{\text{INCHES}}{\text{MILLIMETERS}}$
 *THESE DIMENSIONS DO NOT INCLUDE MOLD FLASH OR PROTRUSIONS.
 MOLD FLASH OR PROTRUSIONS SHALL NOT EXCEED .010 INCH (0.254mm)

N14 1002

PACKAGE DESCRIPTION

SW Package 16-Lead Plastic Small Outline (Wide .300 Inch) (Reference LTC DWG # 05-08-1620)

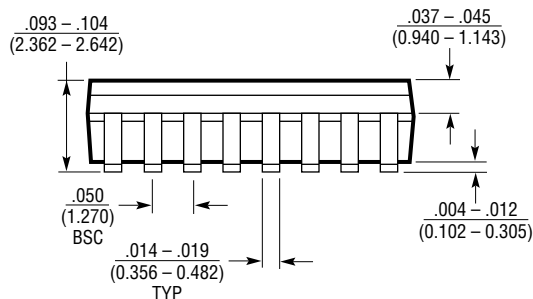
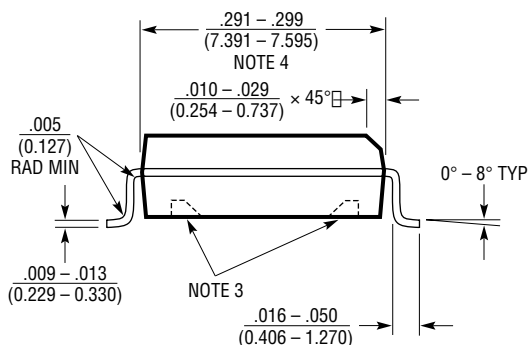
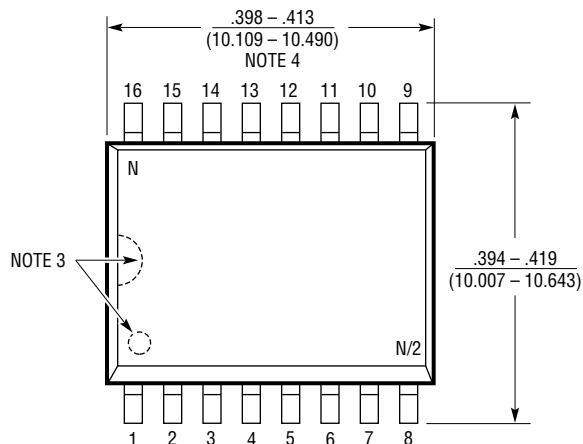
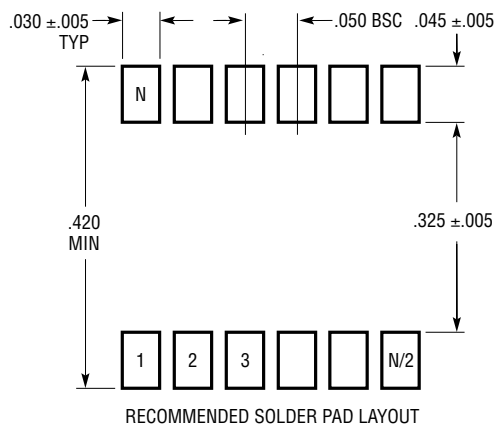

- NOTE:
1. DIMENSIONS IN $\frac{\text{INCHES}}{\text{MILLIMETERS}}$
 2. DRAWING NOT TO SCALE
 3. PIN 1 IDENT, NOTCH ON TOP AND CAVITIES ON THE BOTTOM OF PACKAGES ARE THE MANUFACTURING OPTIONS. THE PART MAY BE SUPPLIED WITH OR WITHOUT ANY OF THE OPTIONS
 4. THESE DIMENSIONS DO NOT INCLUDE MOLD FLASH OR PROTRUSIONS. MOLD FLASH OR PROTRUSIONS SHALL NOT EXCEED .006" (0.15mm)

S16 (WIDE) 0602

TYPICAL APPLICATIONS

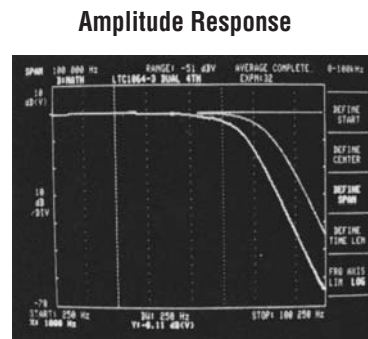
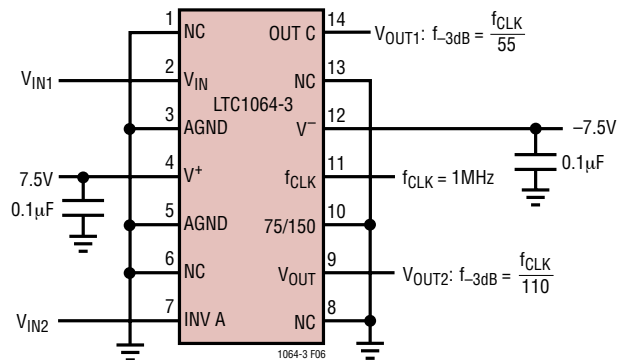

Figure 6. Dual 4th Order Bessel Filters. $V_S = \pm 7.5V$, $f_{CLK} = 1MHz$, Pin 10 to GND. $f_{-3dB} = 9kHz$ and $18kHz$

RELATED PARTS

PART NUMBER	DESCRIPTION	COMMENTS
LTC1069-7	8th Order Linear Phase Lowpass	S0-8 Package
LTC1563	Active RC, 4th Order Bessel Lowpass	Continuous Time, Resistor Programmable Cutoff
LTC1569-6	DC Accurate, 10th Order Lowpass	Linear Phase, Internal Precision Clock, S0-8 Package
LTC1569-7	DC Accurate, 10th Order Lowpass	Linear Phase, Internal Precision Clock, S0-8 Package



Компания «ЭлектроПласт» предлагает заключение долгосрочных отношений при поставках импортных электронных компонентов на взаимовыгодных условиях!

Наши преимущества:

- Оперативные поставки широкого спектра электронных компонентов отечественного и импортного производства напрямую от производителей и с крупнейших мировых складов;
- Поставка более 17-ти миллионов наименований электронных компонентов;
- Поставка сложных, дефицитных, либо снятых с производства позиций;
- Оперативные сроки поставки под заказ (от 5 рабочих дней);
- Экспресс доставка в любую точку России;
- Техническая поддержка проекта, помощь в подборе аналогов, поставка прототипов;
- Система менеджмента качества сертифицирована по Международному стандарту ISO 9001;
- Лицензия ФСБ на осуществление работ с использованием сведений, составляющих государственную тайну;
- Поставка специализированных компонентов (Xilinx, Altera, Analog Devices, Intersil, Interpoint, Microsemi, Aeroflex, Peregrine, Syfer, Eurofarad, Texas Instrument, Miteq, Cobham, E2V, MA-COM, Hittite, Mini-Circuits, General Dynamics и др.);

Помимо этого, одним из направлений компании «ЭлектроПласт» является направление «Источники питания». Мы предлагаем Вам помощь Конструкторского отдела:

- Подбор оптимального решения, техническое обоснование при выборе компонента;
- Подбор аналогов;
- Консультации по применению компонента;
- Поставка образцов и прототипов;
- Техническая поддержка проекта;
- Защита от снятия компонента с производства.



Как с нами связаться

Телефон: 8 (812) 309 58 32 (многоканальный)

Факс: 8 (812) 320-02-42

Электронная почта: org@eplast1.ru

Адрес: 198099, г. Санкт-Петербург, ул. Калинина, дом 2, корпус 4, литера А.