

## DESCRIPTION

Hybrid microwave integrated circuit applications utilizing stripline or microstrip substrates generally require that the active components be of appropriate size and integrity so that the physical constraints imposed by handling and bonding and electrical performance demands can be met. The GC4800 series planar PIN diodes are offered to meet the above MIC demands as well as conform to established industry norms on minimum expected performance and geometric format and convention.

The device structure consists of two plated co-planar leads (commonly referred to as “beams”) extending from the “P” and “N” type contacts selectively located on the semiconductor substrate. Our application notes offer an explanation of the device’s operational characteristics and how they may be useful in specific circuit designs.

Thermal oxide junction passivation is incorporated into the structural design for electrical permanence (low conductive leakage, stable capacitance and reverse breakdown voltage).

This series of devices meets RoHS requirements per EU Directive 2002/95/EC.

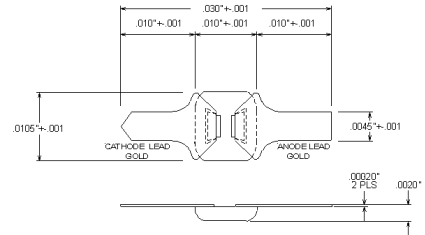

## KEY FEATURES

- Low Series Resistance
- Low Capacitance
- Fast Switching
- Electrically Stable Performance
- Sound Device Construction
- Performance through 18 GHz
- RoHS Compliant

## APPLICATIONS

The GC4800 series beam lead PIN diodes, with their characteristically low series resistance, low junction capacitance and low parasitic reactance, are ideally suited for low power series or shunt switching, limiting, phase shifting, attenuating and demodulating applications in stripline or microstrip format through Ku band. The GC4801, with its low series resistance and junction capacitance, would be a better choice for applications requiring high isolation in a series mode switch. Please refer to *MicroNote 713* for device and circuit design information as well as helpful tips on handling and bonding.

## APPLICATIONS/BENEFITS

- High Speed Switching
- Broadband Performance
- Suitable for Applications through 26 GHz

## ABSOLUTE MAXIMUM RATINGS @ 25° C (Unless Otherwise Specified)

Rating	Symbol	Value	Unit
Maximum Leakage Current @80% of minimum Rated $V_B$	$I_R$	0.5	uA
Operating Temperature	$T_{OP}$	-55 to +150	°C
Storage Temperature	$T_{STG}$	-65 to +150	°C



These devices are ESD sensitive and must be handled using ESD precautions. For the most current data, consult our website: [www.MICROSEMI.com](http://www.MICROSEMI.com). Specifications are subject to change, consult factory for the latest information.

<sup>1</sup> The GC4800 Series of products are supplied with a RoHS compliant Gold finish.

**ELECTRICAL PARAMETERS @ 25°C** (Unless Otherwise Specified)

Model Number	$V_b$ (V) $I_R=10\mu A$ (Min)	$C_T$ (pF) @10V (Typ / Max)	$C_T$ (pF) @50V (Typ / Max)	$R_s$ (Ω) @20mA (Typ / Max)	$R_s$ (Ω) @50mA (Typ / Max)	$T_L$ (nS) (Typ)	$T_s$ (nS) (Typ)	$V_F$ (V) $I_F=50mA$ (Typ)
GC4800A – 14	80	0.016 / 0.020	--	4.5 / 6.5		150	30	1.0
GC4801 – 14	100		0.018 / 0.020		3.5 / 4.0	150	30	1.0
GC4802 – 14	100		0.060 / 0.070		2.2 / 3.0	150	30	1.0
GC4810 - 16	150		0.025 / 0.035		3.0 / 4.0	300	50	1.0

**Notes:**

1 –  $R_s$  and  $C_T$  are determined using Loss and Isolation measurements at  $F = 2.2$  GHz.

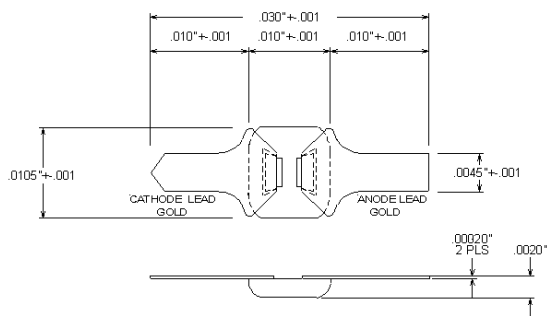
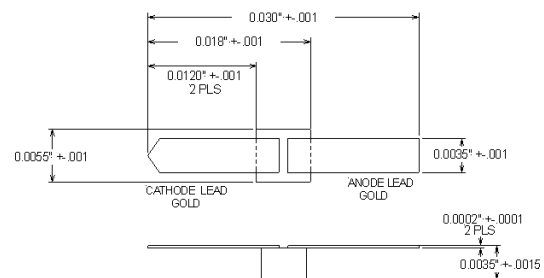
**PACKAGE STYLE 14**

**PACKAGE STYLE 16**

# Mouser Electronics

Authorized Distributor

Click to View Pricing, Inventory, Delivery & Lifecycle Information:

[Microchip:](#)

[GC4802-14](#) [GC4810-16](#)



Компания «ЭлектроПласт» предлагает заключение долгосрочных отношений при поставках импортных электронных компонентов на взаимовыгодных условиях!

Наши преимущества:

- Оперативные поставки широкого спектра электронных компонентов отечественного и импортного производства напрямую от производителей и с крупнейших мировых складов;
- Поставка более 17-ти миллионов наименований электронных компонентов;
- Поставка сложных, дефицитных, либо снятых с производства позиций;
- Оперативные сроки поставки под заказ (от 5 рабочих дней);
- Экспресс доставка в любую точку России;
- Техническая поддержка проекта, помощь в подборе аналогов, поставка прототипов;
- Система менеджмента качества сертифицирована по Международному стандарту ISO 9001;
- Лицензия ФСБ на осуществление работ с использованием сведений, составляющих государственную тайну;
- Поставка специализированных компонентов (Xilinx, Altera, Analog Devices, Intersil, Interpoint, Microsemi, Aeroflex, Peregrine, Syfer, Eurofarad, Texas Instrument, Miteq, Cobham, E2V, MA-COM, Hittite, Mini-Circuits, General Dynamics и др.);

Помимо этого, одним из направлений компании «ЭлектроПласт» является направление «Источники питания». Мы предлагаем Вам помощь Конструкторского отдела:

- Подбор оптимального решения, техническое обоснование при выборе компонента;
- Подбор аналогов;
- Консультации по применению компонента;
- Поставка образцов и прототипов;
- Техническая поддержка проекта;
- Защита от снятия компонента с производства.



#### Как с нами связаться

**Телефон:** 8 (812) 309 58 32 (многоканальный)

**Факс:** 8 (812) 320-02-42

**Электронная почта:** [org@eplast1.ru](mailto:org@eplast1.ru)

**Адрес:** 198099, г. Санкт-Петербург, ул. Калинина, дом 2, корпус 4, литера А.