

BMP388

Digital pressure sensor



BMP388 – Datasheet

Document revision	1.1
Document release date	March 2018
Document number	BST-BMP388-DS001-01
Technical reference code(s)	0 273 300 511

Notes Data and descriptions in this document are subject to change without notice. Product photos and pictures are for illustration purposes only and may differ from the real product appearance.



BMP388

Digital pressure sensor

The BMP388 is a digital sensor with pressure and temperature measurement based on proven sensing principles. The sensor module is housed in an extremely compact 10-pin metal-lid LGA package with a footprint of only $2.0 \times 2.0 \text{ mm}^2$ and max 0.8 mm package height. Its small dimensions and its low power consumption of $3.4 \mu\text{A} @ 1\text{Hz}$ allow the implementation in battery driven devices such as mobile phones, GPS modules or watches.

Typical applications

- Vertical velocity indication (e.g. rise/sink speed)
- Internet of things
- Enhancement of GPS navigation
(e.g. time-to-first-fix improvement, dead-reckoning, slope detection)
- Indoor navigation & localization (floor detection, elevator detection)
- Outdoor navigation, leisure and sports applications
- Weather forecast
- Health care applications (e.g. spirometry)
- Fitness applications like enhancement of calorie detection
- AR & VR applications
- Context awareness

Target Devices

- Flying toys
- Drones
- Handsets such as mobile phones, tablet PCs, GPS devices
- Navigation systems
- Portable health care devices
- Home weather stations
- Watches
- White goods

Key features

Table 1: Key Features of BMP388

Package	2.0 mm x 2.0 mm x 0.75 mm metal lid LGA
Digital interface	I ² C (up to 3.4 MHz) and SPI (3 and 4 wire, up to 10 MHz)
Supply voltage	V _{DD} main supply voltage range: 1.65 V to 3.6 V V _{DDIO} interface voltage range: 1.2 V to 3.6 V
Relative accuracy	typ. ± 8 Pa, equiv. to ± 0.66 m (900 ... 1100 hPa, 25 ... 40 °C)
Absolute accuracy	typ. ± 50 Pa (300 ... 1100 hPa, -20 ... +65 °C)
Temperature coefficient offset	typ. ± 0.75 Pa/K (0 ... 55°C @ 700 -1100 hPa)
Current consumption	3.4 µA at 1 Hz pressure and temperature 2.0 µA in sleep mode
Operating range	-40 – +85 °C, 300–1250 hPa
The product is RoHS compliant, halogen-free, MSL1	

BMP388 enables accurate altitude tracking and is specifically suited for drone applications. The best-in-class TCO between -20-65°C for accurate altitude measurement over a wide temperature range of the BMP388 greatly enhance the drone flying experience by making accurate steering easier. It is compatible for use with other Bosch sensors, including the new BMI088 for better performance, robustness and stability. The new BMP388 sensor offers outstanding design flexibility, providing a single package solution that can also be easily integrated into other existing and upcoming devices such as smart homes, industrial products and wearables.

The sensor is more accurate than its predecessor BMP280, covering a wide measurement range from 300 hPa to 1250 hPa. This new barometric pressure sensor exhibits an attractive price-performance ratio coupled with low power consumption. It is available in a compact 10-in 2.0 x 2.0 x 0.75 mm³ LGA package with metal lid

Due to the built-in hardware synchronization of the pressure sensor data and its ability to synchronize data from external devices such as acceleration sensors, the BMP388 is ideally suited for fitness and navigation applications which require highly accurate, low power and low latency sensor data fusion.

The new interrupt functionality provides simple access to data and storage. Examples of interrupts that can be used in a power efficient manner without using software algorithms include: Data ready interrupt, watermark interrupt (on byte level) or FIFO full interrupt.

BMP388 also includes a new FIFO functionality. This greatly improves ease of use while helping to reduce power consumption of the overall device system during full operation. The integrated 512 byte FIFO buffer supports low power applications and prevents data loss in non-real-time systems.

Table of contents

1. Specification	6
2. Absolute maximum ratings	8
3. Functional description	8
3.1. Block diagram	9
3.2. Power management	10
3.3. Power modes	10
3.4. Measurement flow	12
3.5. Filter selection	16
3.6. FIFO Description	17
3.7. Interrupts	21
3.8. Current consumption	25
3.9. Measurement timings	25
3.10. Data readout from data registers	26
3.11. Output compensation	27
4. Global memory map and register description	28
4.1. General remarks	28
4.2. Datasheet Memory Map	28
4.3. Register description	30
5. Digital interfaces	39
5.1. Interface selection	39
5.2. I ² C Interface	39
5.3. SPI interface	41
5.4. Interface parameter specification	42
6. Pin-out and connection diagram	45
6.1. Pin-out	45
6.2. Connection diagram $\frac{3}{4}$ -wire SPI	46
6.3. Connection diagram I ² C	47
7. Package, reel and environment	48
7.1. Outline dimensions	48
7.2. Landing pattern	48

7.3.	Marking	49
7.4.	Soldering guidelines	50
7.5.	Tape and reel specification	51
7.6.	Mounting and assembly recommendations	51
7.7.	Environmental safety	52
8.	Legal disclaimer	53
8.1.	Engineering samples	53
8.2.	Product use.....	53
8.3.	Application examples and hints	53
9.	Appendix: Computation formulae reference implementation.....	54
9.1.	Calibration coefficient	54
9.2.	Temperature compensation	54
9.3.	Pressure compensation	55
10.	Document history and modification	56

1. Specification

If not stated otherwise,

- All values are valid over the full voltage range
- All minimum/maximum values are given for the full accuracy temperature range
- Minimum/maximum values of drifts, offsets and temperature coefficients are $\pm 3\sigma$ values over lifetime
- Typical values of currents and state machine timings are determined at 25 °C
- Typical values of currents and state machine timings are determined at 25°C. minimum/maximum values of currents are determined at -40°C/85°C.
- Minimum/maximum values of state machine timings are determined using corner lots over 0...+65 °C temperature range.

Table 2: General electrical parameter specifications

OPERATING CONDITIONS BMP388						
Parameter	Symbol	Condition	Min	Typ	Max	Unit
Operating temperature range	T _A	operational	-40	25	+85	°C
		full accuracy	0		+65	
Operating pressure range	P	full accuracy	300		1250	hPa
Sensor supply voltage	V _{DD}	ripple max. 50mVpp	1.65	1.8	3.6	V
Interface supply voltage	V _{DDIO}		1.2	1.8	3.6	V
Sleep current	I _{DD,sleep}	V _{DD} = V _{DDIO} 1.8-3.6 V		2		µA
Peak current	I _{peak}	during pressure measurement		700	800	µA
Current at temperature measurement	I _{DDT}			300	400	µA
Relative accuracy pressure	A _{rel}	900 ... 1100 hPa 25 ... 40 °C		±0.08 ¹		hPa
				±66		cm
Offset temperature coefficient	TCO	700-1100 hPa 0 ... 55 °C		±0.75		Pa/K
		700-1100 hPa -20 ... 0 °C		±1.0		Pa/K
Absolute accuracy pressure	A ^P _{full}	300. . 1100 hPa -20 ... 65 °C		±0.50		hPa
	A ^P _{ext}	900. . 1100 hPa 25 ... 40 °C		±0.40		hPa
	A ^P	1100 . . 1250 hPa 0 . . 65 °C	-1.5	±0.50	1.5	hPa

¹ Mean value

Resolution of output data in highest resolution mode at lowest bandwidth	R^P	Pressure		0.016		Pa
Noise in pressure	$V_{p,full}$	Full bandwidth, highest resolution See chapter 3.4.4		1.2		Pa
	$V_{p,filtered}$	Lowest bandwidth, highest resolution See chapter 3.4.4		0.03		Pa
Absolute accuracy temperature²	A^T	@ 25 °C		±0.3		°C
		0 ... +65 °C		±0.50		°C
Long term stability³	ΔP_{stab}	12 months		±0.33		hPa
Solder drifts		Minimum solder height 50 μ m		< ±1.0		hPa
Start-up time	$t_{startup}$	Time to first communication after both $V_{DD} > 1.58V$ and $V_{DDIO} > 0.65V$			2	ms
Possible sampling rate	f_{sample}	$osrs_t = osrs_p = 1$; See chapter 3.9			200	Hz
ODR accuracy	$\Delta t_{standby}$	25°C		2	+/- 12 ⁴	%

² Temperature measured by the internal temperature sensor. This temperature value depends on the PCB temperature, sensor element self-heating and ambient temperature and is typically above ambient temperature.

³ Long term stability is specified in the full accuracy operating pressure range 0 ... 65°C

⁴ From -40 to 85°C

2. Absolute maximum ratings

The absolute maximum ratings are provided in Table 3 .

Table 3: Absolute maximum ratings

Parameter	Symbol	Condition	Min	Max	Unit
Voltage at any supply pin		V_{DD} and V_{DDIO} Pin	-0.3	3.8	V
Voltage at any interface pin			$V_{SS} - 0.3$	$V_{DDIO} + 0.3$	V
Storage temperature		$\leq 65\%$ rel. H.	-45	+85	$^{\circ}\text{C}$
Overpressure survivability	P_{OVER}			2 000 000	Pa
Mechanical shock	M_S	MIL-STD-883H 2002.5		12000	g
Maximum allowable dust particle inside package	$Dust_{MAX}$	ISO 12103-1 A2		300 ⁵	μm
ESD		Charge device model (CDM)	Class C2a: 500V to <750V		
		Human body model (HBM)	Class 2: 2 kV		

Note: Stresses above these listed maximum ratings may cause permanent damage to the device. Exposure beyond specified electrical characteristics (Table 2) may affect device reliability or cause malfunction.

3. Functional description

The BMP388 consists of a Piezo-resistive pressure sensing element and a mixed-signal ASIC. The ASIC performs A/D conversions and provides the conversion results and sensor specific compensation data through a digital interface.

BMP388 provides highest flexibility to the designer and can be adapted to the requirements regarding accuracy, measurement time and power consumption by selecting from a high number of possible combinations of the sensor settings.

BMP388 can be operated in three power modes (see section 3.3):

sleep mode | normal mode | forced mode

In sleep mode, no measurements are performed. Normal mode comprises an automated perpetual cycling between an active measurement period and an inactive standby period. In forced mode, a single measurement is performed. When the measurement is finished, the sensor returns to sleep mode.

⁵ Defined by hole size

A set of oversampling settings is available ranging from ultra-low power to highest resolution setting in order to adapt the sensor to the target application. The settings are predefined combinations of pressure measurement oversampling and temperature measurement oversampling. Pressure and temperature measurement oversampling can be selected independently from 0 to 32 times oversampling (see sections 3.4.1 and 3.4.2):

- Temperature measurement
- Ultra low power
- Low power
- Standard resolution
- High resolution
- Ultra high resolution
- Highest resolution

BMP388 is equipped with a built-in IIR filter in order to minimize short-term disturbances in the output data caused by the slamming of a door or window. The filter coefficient ranges from 0 (off) to 127.

3.1. Block diagram

Figure 1 shows a simplified block diagram of the BMP388:

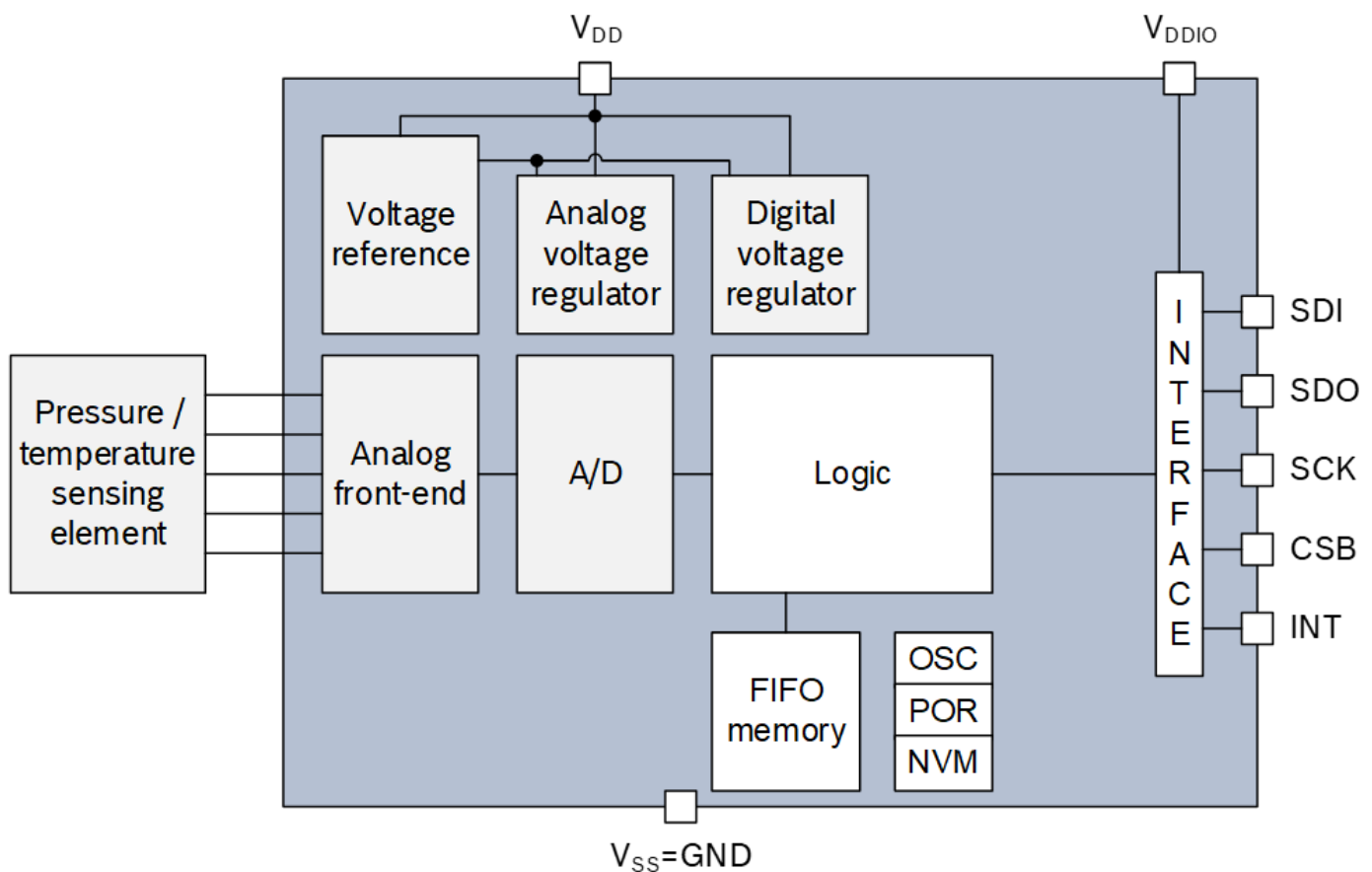

Figure 1: Block Diagram BMP388

3.2. Power management

The BMP388 has two separate power supply pins

- V_{DD} is the main power supply for all internal analog and digital regulator blocks.
- V_{DDIO} is a separate power supply pin, used for the supply of the digital interface.

V_{DD} and V_{DDIO} pins can be energized in any order.

A power-on reset generator is built in which resets the logic circuitry and the register values after the power-on sequence. The slope for ramp up time must not be less than 10 ms. After powering up, the sensor settles in sleep mode (see section 3.3).

Completion of the power-on-reset or soft reset is indicated by the bit *por_detected[0]*. The bit is cleared after reading.

Holding any interface pin (SDI, SDO, SCK or CSB) at a logical high level when V_{DDIO} is switched off can permanently damage the device due caused by excessive current flow through the ESD protection diodes.

3.3. Power modes

The BMP388 offers three power modes: sleep mode, forced mode and normal mode. These can be selected using the *mode[1:0]* bits in control register “*pwr_ctrl*”.

Table 4: mode settings

<i>mode[1:0]</i>	Mode
00	Sleep mode
01 and 10	Forced mode
11	Normal mode

3.3.1. Sleep mode

Sleep mode is set by default after power on reset. In sleep mode, no measurements are performed and power consumption (I_{DDSL}) is at a minimum. All registers are accessible; Chip-ID and compensation coefficients can be read.

3.3.2. Forced mode

In forced mode, a single measurement is performed according to selected measurement and filter options. When the measurement is performed, the sensor returns to sleep mode and the measurement results can be obtained from the data registers. For a next measurement, forced mode needs to be selected again. Forced mode is recommended for applications which require low sampling rate or host-based synchronization.

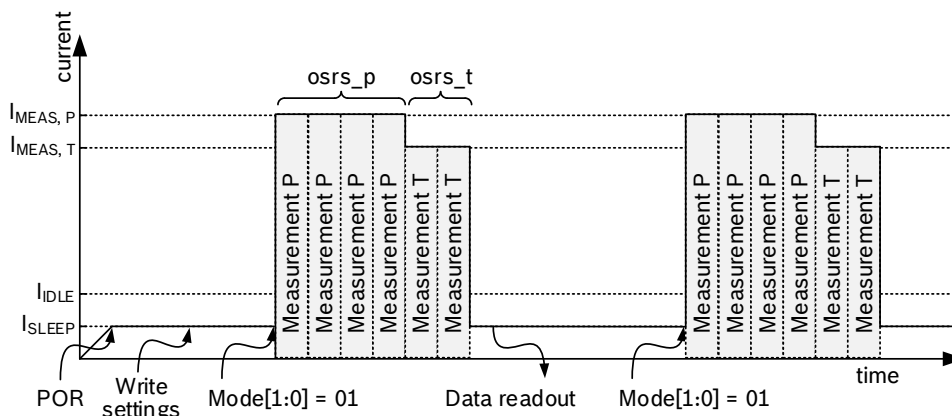

Figure 2: Force mode timing diagram

3.3.3. Normal mode

Normal mode continuously cycles between an (active) measurement period and an (inactive) standby period. The measurement rate is set in the *odr_sel* register (see 4.3.17), where various prescaler for sample frequencies $f_{\text{sampling}}=200\text{Hz}$ can be selected. The sampling period τ calculated by

$$\tau_{\text{sampling}} = \text{prescaler} / f_{\text{sampling}}$$

After setting the mode, measurement and filter options, the last measurement results can be obtained from the data registers without the need of further write accesses. Normal mode is recommended when using the IIR filter, and useful for applications in which short-term disturbances (e.g. blowing into the sensor) should be filtered.

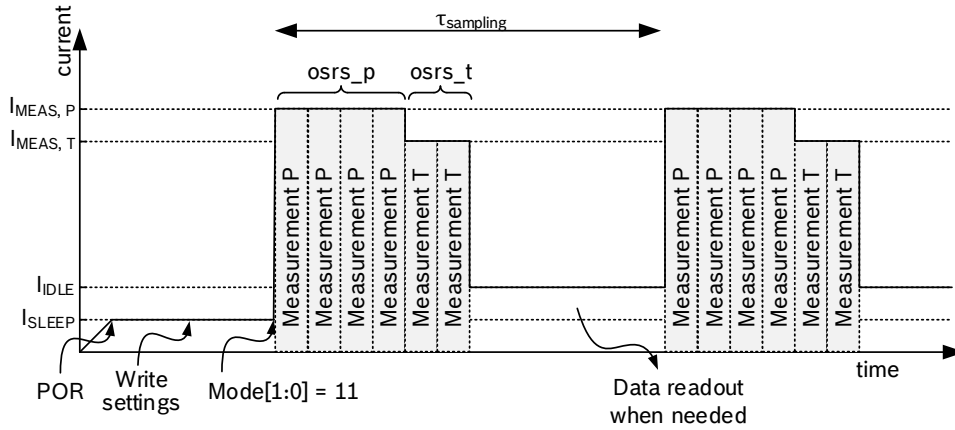

Figure 3: Normal mode timing diagram

3.3.4. Mode transition diagram

The supported mode transitions are displayed below. If the device is currently performing a measurement, execution of mode switching commands is delayed until the end of the currently running measurement period. Further mode change commands are ignored until the last mode change command is executed. Also, mode change commands that are not legal are ignored.

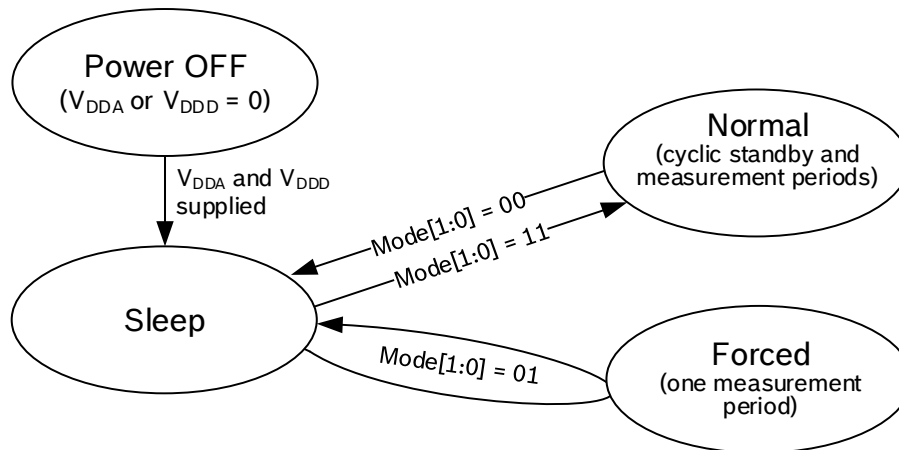

Figure 4: Mode transition diagram

3.4. Measurement flow

The BMP388 measurement period consists of a temperature and pressure measurement with selectable oversampling. After the measurement period, the data are passed through an optional IIR filter, which removes short-term fluctuations in pressure (e.g. caused by slamming a door). The flow is depicted in the diagram below.

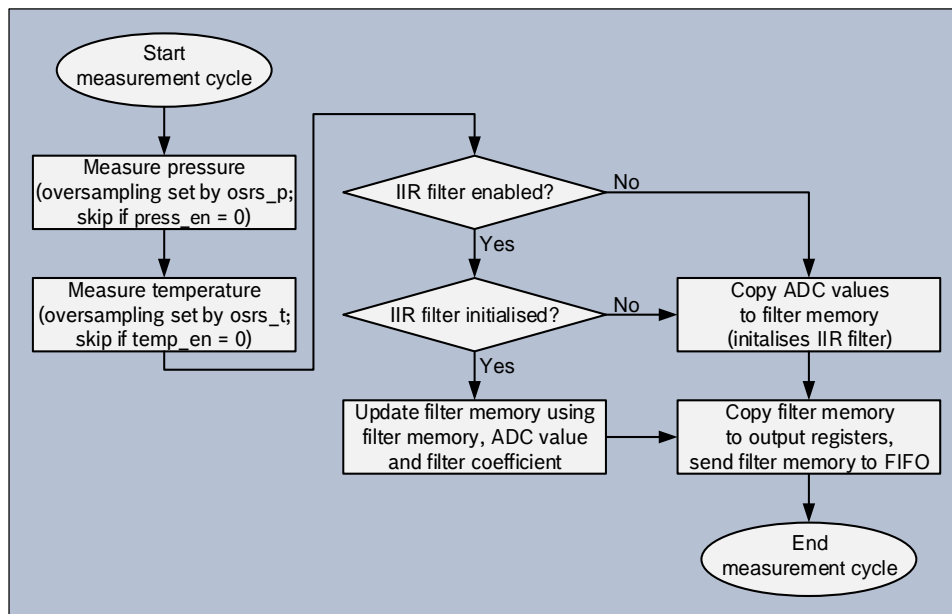

Figure 5: BMP388 measurement cycle

The individual blocks of the diagram above will be detailed in the following subsections.

3.4.1. Pressure measurement

Pressure measurement can be enabled or skipped. Skipping the measurement could be useful if BMP388 is used as temperature sensor. When enabled, several oversampling options exist. Each oversampling step reduces noise and increases the output resolution by one bit, which is stored in the XLSB data register.

Enabling the measurement is selected by `press_en` bit in “`PW_CTRL[0]`” register (see 4.3.15). The oversampling setting `osr_p` can be configured in “`OSR[2:0]`” register (see 4.3.16).

Table 5: `osr_p` settings

Oversampling setting	<code>osr_p</code>	Pressure oversampling	Typical pressure resolution	Recommended temperature oversampling
Ultra low power	000	×1	16 bit / 2.64 Pa	×1
Low power	001	×2	17 bit / 1.32 Pa	×1
Standard resolution	010	×4	18 bit / 0.66 Pa	×1
High resolution	011	×8	19 bit / 0.33 Pa	×1
Ultra high resolution	100	×16	20 bit / 0.17 Pa	×2
Highest resolution	101	×32	21 bit / 0.085 Pa	×2

3.4.2. Temperature measurement

Temperature measurement can be enabled or skipped. Skipping the measurement could be useful to measure pressure extremely rapidly. When enabled, several oversampling options exist. Each oversampling step reduces noise and increases the output resolution by one bit, which is stored in the XLSB data register. Noise and increases the output resolution by one bit, which is stored in the XLSB data register.

Enabling the measurement is selected by `temp_en` bit in “`PW_CTRL[1]`” register (see 4.3.15). The oversampling setting `osr_t` can be configured in “`OSR[5:3]`” register (see 4.3.16).

Table 6: `osrs_t` settings

<code>osr_t</code>	Temperature oversampling	Typical temperature resolution
000	×1	16 bit / 0.0050 °C
001	×2	17 bit / 0.0025 °C
010	×4	18 bit / 0.0012 °C
011	×8	19 bit / 0.0006 °C
100	×16	20 bit / 0.0003 °C
101	×32	21 bit / 0.00015 °C

It is recommended to base the value of `osr_t` on the selected value of `osr_p` as per Table 5. Temperature oversampling above ×2 is possible, but will not significantly improve the accuracy of the pressure output any further. The reason for this is that the noise of the compensated pressure value depends more on the raw pressure than on the raw temperature noise. Following the recommended setting will result in an optimal noise-to-power ratio.

3.4.3. IIR filter

The environmental pressure is subject to many short-term changes, caused e.g. by slamming of a door or window, or wind blowing into the sensor. To suppress these disturbances in the output data without causing additional interface traffic and processor work load, the BMP388 features an internal IIR filter. It effectively reduces the bandwidth of the output signals⁶. The output of a next measurement step is filter using the following formula:

$$data_{filtered} = \frac{data_{filtered_old} * filter_coefficient + data_{ADC}}{filter_coefficient + 1}$$

where $data_filtered_old$ is the data coming from the previous acquisition, and $data_ADC$ is the data coming from the ADC before IIR filtering.

The IIR filter can be configured using setting iir_filter in “CONFIG” register (see 4.3.18).

When writing to the register $filter$, the filter is reset. The next value will pass through the filter and be the initial memory value for the filter. IIR filter is reset if the temperature or pressure measurement is disabled ($temp_en$ or $press_en$ registers changed from ‘1’ to ‘0’) or when a transition from sleep mode to normal mode occurs. After enabling of pressure or temperature measurement, the filtering will start, thus the next incoming value will pass unfiltered and be the initial value of the IIR filter.

The step response (e.g. response to in sudden change in height) of different filter settings is displayed in Figure 6.

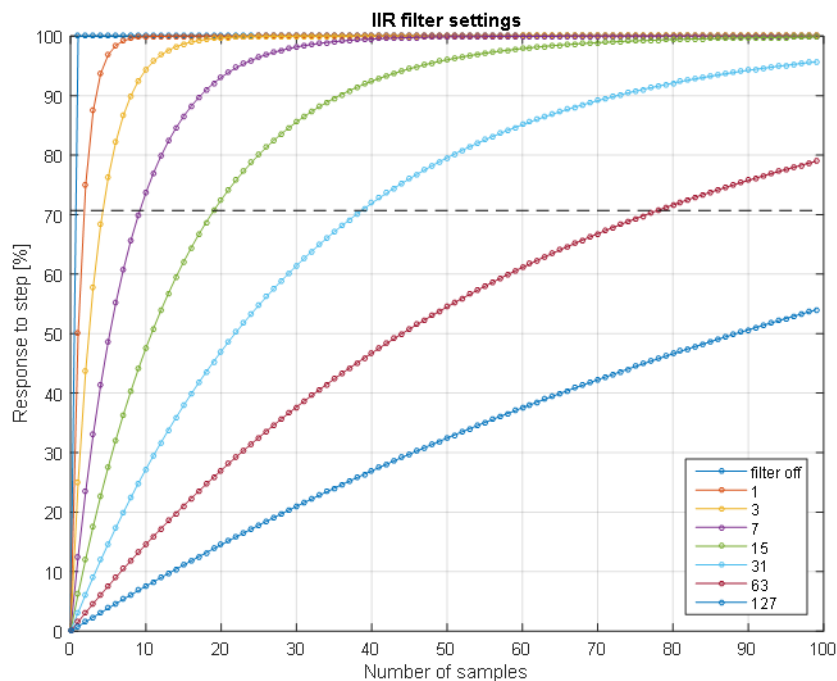

Figure 6: Step response at different IIR filter settings

3.4.4. Oversampling

Noise depends on the oversampling and filter settings selected. The stated values were determined in a controlled pressure environment and are based on the average standard deviation of 32 consecutive measurement points taken at highest sampling rate (for details please refer to Table 21). This is required to exclude long term drifts from the noise measurement.

⁶ Since most pressure sensors do not sample continuously, filtering can suffer from signals with a frequency higher than the sampling rate of the sensor. E.g. environmental fluctuations caused by windows being opened and closed might have a frequency <5 Hz. Consequently, a sampling rate of ODR = 10 Hz is sufficient to obey the Nyquist theorem.

Table 7: Noise in pressure
Typical RMS noise in pressure [Pa]

Oversampling setting	IIR filter coefficient							
	off	2	4	8	16	32	64	128
Ultra low power	6.6	3.8	2.5	1.7	1.2	0.8	0.6	0.4
Low power	4.3	2.5	1.6	1.1	0.8	0.5	0.4	0.3
Standard resolution	3.2	1.8	1.2	0.8	0.6	0.4	0.3	0.2
High resolution	2.3	1.3	0.9	0.6	0.4	0.3	0.2	0.1
Ultra high resolution	1.6	0.9	0.6	0.4	0.2	0.2	0.1	0.1
Highest resolution	1.2	0.7	0.4	0.3	0.3	0.1	0.1	<0.1

Table 8: Noise in temperature
Typical RMS noise in temperature [°C]

Temperature oversampling	IIR filter off
Ultra low power	0.005
Low power	0.005
Standard resolution	0.005
High resolution	0.005
Ultra high resolution	0.004
Highest resolution	0.003

3.5. Filter selection

In order to select optimal settings, the following use cases are suggested:

Table 9: Recommended filter settings based on use cases

Use case	Mode	Over-sampling setting	osrs_p	osrs_t	IIR filter coeff. (see 4.3.18)	I _{DD} [μA] (see 3.8)	ODR [Hz] (see 3.4.1)	RMS Noise [cm] (see 3.4.4)
handheld device low-power (e.g. Android)	Normal	High resolution	x8	x1	2	145	12.5	11
handheld device dynamic (e.g. Android)	Normal	Standard resolution	x4	x1	4	310	50	10
Weather monitoring (lowest power),	Forced	Ultra low power	x1	x1	Off	4	1/60	55
Drop detection	Normal	Low power	x2	x1	Off	358	100	36
Indoor navigation	Normal	Ultra high resolution	x16	x2	4	560	25	5
Drone	Normal	Standard Resolution	x8	x1	2	570	50	11

3.6. FIFO Description

The BMP388 contains a 512 Bytes FIFO (first-in-first-out) data buffer. To enable data collecting in the FIFO, *fifo_mode* is set at '1' and data to be collected are defined through *fifo_press_en* and *fifo_temp_en*. The FIFO mode is disabled, when no writing is defined which according to the following two cases:

- *fifo_mode*='0'
- *fifo_mode*='1' and *fifo_press_en*='0' and *fifo_temp_en*='0'

If the FIFO is disabled when FIFO byte count is greater than 0, no new frame is written to the FIFO, but FIFO is operational:

- Frames already written in the FIFO remain stored and can be read out
- FIFO interrupts and their corresponding statuses are still evaluated
- after all bytes are read out, Sensortime (if enabled) and Empty frames are generated
- FIFO can be flushed

3.6.1. FIFO input data

Storing of pressure and/or temperature measurement results is enabled by setting *fifo_press_en*='1' and *fifo_temp_en*='1' respectively. Storing of data can be enabled or disabled on a per-channel basis in any combination. Filtered or unfiltered data are stored to the FIFO; if *data_select*="01", filtered data are stored, otherwise unfiltered data are stored to the FIFO. The Number of bytes available in FIFO is readable through *fifo_length_1*<0> (MSBs) and *fifo_length_0*<7:0> (LSBs) registers.

The FIFO byte count registers *fifo_length_0* and *fifo_length_1* are updated only when a full frame has been written to FIFO and is available for read-out. FIFO byte count registers are also updated after each full-frame read from the FIFO.

FIFO byte count registers increment or decrement is equal to frame length; intermediate increments (corresponding to a partial frame) are not readable.

3.6.2. FIFO data sampling selection

The FIFO input data rate is reduced by selecting a down-sampling factor in register *fifo_subsampling*. Down-sampling factor ranges from 1 to 128 and is equal to $2^{\text{fifo_subsampling}}$. Down-sampling is applied in the normal mode only and is aligned to the measurement timing grid. Down-sampling counter is reset and data saved to the FIFO at the end of the first measurement when a transition from sleep mode to normal mode occurs.

3.6.3. FIFO read out

FIFO is read out via *fifo_data* register. FIFO reads are never blocked, however an ongoing read from the FIFO does not block writing to the FIFO.

During burst read, the address counter stops incrementing when *fifo_data* address is reached; this allows a complete reading of the FIFO content within one burst read transaction.

3.6.4. FIFO overflow behavior

A FIFO overflow occurs if the FIFO is full and a new data is written to the FIFO. FIFO full means free space is less than maximum frame length (9 bytes). In case of overflow the FIFO can either stop recording data or overwrite the oldest data. The behavior is controlled by register `fifo_stop_on_full`.

- Streaming mode, `fifo_stop_on_full='0'`:
if the new frame does not fit inside the remaining free space in the FIFO RAM, FIFO will repeatedly delete the oldest frame until it creates enough space for the new one.
- FIFO stop-on-full mode, `fifo_stop_on_full='1'`:
The newest frame is discarded. Normal operation resumes if the FIFO full condition no longer persists.

3.6.5. FIFO Frames

One data frame is composed of a header and a set of data organize as described in table below.

Table 10: Data frame composition

Bit	7	6	5	4	3	2	1	0
Header		fh_mode[1:0]		fh_param[3:0]			0	0
Data	Data bytes							

The number of data bytes is defined by the header.

3.6.5.1. Header Format

Table 11: Header format

fh_mode[1:0]	Definition	fh_param[3:0]
10	Sensor frame	Sensor enable bits
01	Control frame: configuration error	0001
01	Control frame: FIFO input configuration change	0010

3.6.5.2. Sensor Frame Format

A sensor frame consists of a header and data bytes

Table 12: Sensor frame format

Bit	7	6	5	4	3	2	1	0
Header	1	0	s	t	0	p	0	0
Data	data bytes							

Sensor data in frame is defined by s (time), t (temperature) and p (pressure) sensor enable bits:

- If `s='1'`, the frame corresponds to the sensor-time frame, in that case, `t=p='0'`
- If `t='1'` or/and `p='1'`, the frame corresponds to a normal pressure or/and a temperature frame
- If `s=t=p='0'`, the frame corresponds to an empty frame

Table 13: Sensor-time frame

Bit	7	6	5	4	3	2	1	0
Header	1	0	1	0	0	0	0	0
Sensor-time	time_xlsb[7:0]							
	time_lsb[7:0]							
	time_msb[7:0]							

The data for the sensor-time frame consists of register sensor_time content at the time the sensortime frame transmission has started. A sensor-time frame is not stored in the FIFO, but append to every FIFO burst read operation after all data has been transmitted if fifo_time_en='1'.

Table 14: Normal pressure and temperature frame

Bit	7	6	5	4	3	2	1	0
Header	1	0	0	1	0	1	0	0
Temp	temp_xlsb[7:0]							
	temp_lsb[7:0]							
	temp_msb[7:0]							
Press	press_xlsb[7:0]							
	press_lsb[7:0]							
	press_msb[7:0]							

If one of t and p is '0', the corresponding data is not part of the frame; the frame is therefore reduced to 4 bytes.

A FIFO empty frame is a sensor frame with no sensor enabled. This frame is returned if the last frames was read-out or if FIFO is empty.

Table 15: FIFO empty frame format

Bit	7	6	5	4	3	2	1	0
Header	1	0	0	0	0	0	0	0
Data	0	0	0	0	0	0	0	0

When a configuration error is detected, a configuration error frame is stored into the FIFO

Table 16: Control frame: configuration error

Bit	7	6	5	4	3	2	1	0
Header	0	1	0	0	0	1	0	0
Opcode	0	0	0	0	0	0	0	1

If FIFO is enabled and a change in registers "FIFO_CONF_2" or "OSR" or "ODR" or "CONFIG" or press_en or temp_en occurs, a control frame is inserted just before the first sensor frame with new configuration is stored to the FIFO. If multiple configuration change becomes active at the same time, only one control frame is inserted. Configuration changes are tracked when the device is in normal mode.

3.6.6. Corner cases

3.6.6.1. Under-read

In case the FIFO is under-read (not all frames were taken from the FIFO, but the last frame read was read entirely), the next readout will continue at the frame that was just about to be sent.

3.6.6.2. Partial frame read

In case the FIFO is under-read and a partial data frame read occurred (not all frames were taken from the FIFO, and the last frame read was not read entirely), the entire last data frame is repeated upon the next read access.

When `fifo_stop_on_full='0'`, the oldest frames are overwritten when new frames are available and the FIFO is full. When this happens, the partially read data frame is not repeated but the oldest frame available in the RAM is sent instead.

Sensortime frame is not repeated when read only partially, its payload always contains current sensortime counter value.

If the read of the frame is interrupted after two or more bits of the frame's last byte were already read, then frame is discarded even though not all bits were read and the frame was read only partially.

3.6.6.3. Over-read

If the burst read continues after all frames have been read out, a sensortime frame is sent after the FIFO becomes empty during a burst read operation if `fifo_time_en='1'`. After that or when FIFO was completely read, the empty frame is returned as long as the burst read is

active.

3.6.7. FIFO flush conditions

The FIFO can be flushed by issuing either *fifo_flush* or a *softreset* in the command register "CMD" (see 4.3.20):

Table 17: `fifo_flush` and `softreset` commands

	Value
<code>fifo_flush</code>	0xB0
<code>softreset</code>	0xB6

3.7. Interrupts

The BMP388 provides an interrupt pin (INT), which allows to signal certain events to the host processor. Different events can be mapped to the interrupt pin, which all are processed with a logical OR.

The available interrupts are listed below and can be read in the “INT_STATUS” register (see 4.3.8):

- FIFO watermark interrupt
- FIFO full interrupt
- Data ready interrupt

3.7.1. Interrupt default mode

After a power-on or soft reset has completed, the interrupt pin is in push-pull and active high mode.

3.7.2. Interrupt pin latching

The chip can be operated in non-latched or latched mode:

- Non-latched mode: Interrupts' conditions are selected as contributors to the INT pad. INT pad is de-asserted as soon as the conditions of all the interrupts propagated to the INT pad are not valid. For data ready, interrupt contribution is de-asserted by reading *int_status* or after 2.5ms after assertion of the interrupt. For FIFO interrupts, INT pad contributions are not affected by *fifo_data* readings, only by the interrupt conditions
- Latched mode: Interrupt statuses are selected as contributors of the INT pad.

The minimum interrupt pulse width is $T_{int} = 1\mu s$

3.7.3. Monitoring

The status of interrupt bits is always visible in the “INT_STATUS” register. (see 4.3.8) for details.

3.7.4. Interrupt Pin Configuration

The interrupt pin / pad is configured by the Bits in the “INT_CTRL” register (see 4.3.14). However, the status bits are not influenced thereby.

The output mode of the INT pad is controlled by *int_od* bit:

Table 18: *int_od*

<i>int_od</i> ='0'	Push-pull
<i>int_od</i> ='1'	Open-drain

The level of the interrupt pad can be configured and switched by *int_level* between active low and active high:

Table 19: *int_level*

<i>int_level</i> ='0'	active_low
<i>int_level</i> ='1'	active_high

The latching of interrupts for INT pad and INT_STATUS register can be enabled by *int_latch*='1' or disabled by *int_latch*='0'.

FIFO interrupts are mapped to the INT pad by enabling the respective functions. For mapping FIFO watermark reached interrupt to the pad, the *fwm_en* bit shall be written to '1' (disabling by '0'). The FIFO full interrupt can be mapped by writing *ffull_en* with '1'.

3.7.5. Interrupt functions

3.7.5.1. FIFO watermark interrupt

The FIFO watermark interrupt is used to signal, that fill level of the FIFO has reached a pre-set limit.

$$Fifo_length_1 \ \& \ fifo_length_0 \ \geq \ fifo_wtm_1 \ \& \ fifo_wtm_0$$

The watermark level can be set and adjusted by the user by writing the registers and 0x15 "FIFO_WTM_0" and 0x16 "FIFO_WTM_1" (see 4.3.11) in a single burst transaction. If the FIFO watermark level is set to zero, the interrupt condition will never be satisfied.

The status of the watermark interrupt can be read back through the *fwm_int* bit. The interrupt condition is also updated after the end of a serial interface transaction which wrote into the registers *fifo_wtm_0* or *fifo_wtm_1*.

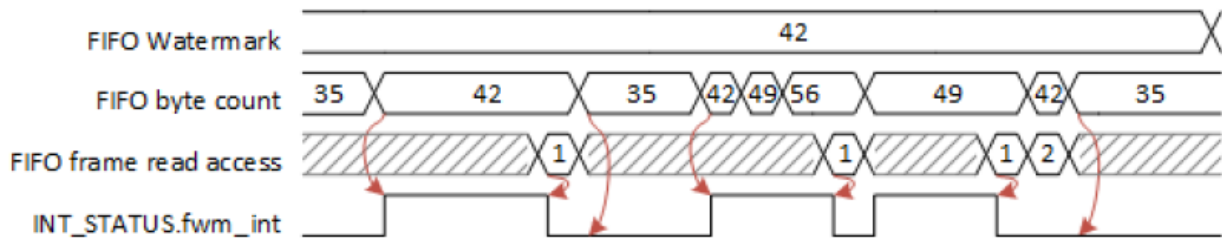

Figure 7: FIFO watermark interrupt, non-latched with reads from FIFO

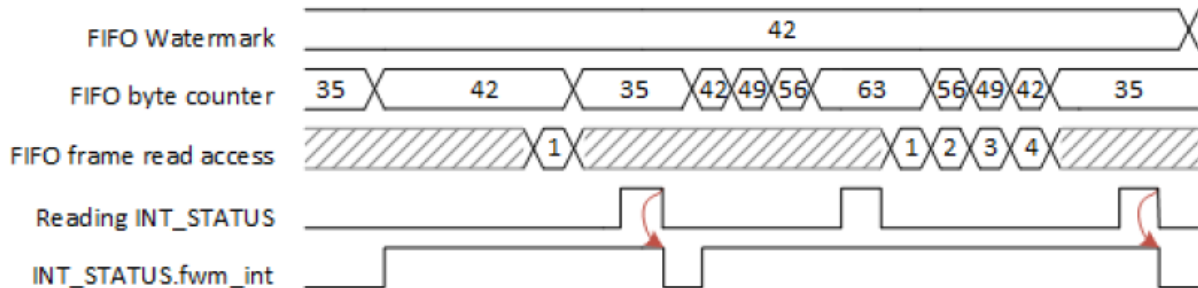

Figure 8: FIFO watermark interrupt, latched, with reads from FIFO

3.7.5.2. FIFO full interrupt

FIFO Full interrupt status is asserted when the full interrupt condition is satisfied, when the filling level of the FIFO number of unread bytes in the FIFO = $fifo_length_1 \& \text{ fifo_length_0}$ is equal or higher than 504.

The status of the FIFO full interrupt can be read back through the `full_int` bit. Interrupt status is cleared by reading the `full_int` bit high '1' when the FIFO filling level is lower than 504.

The FIFO full interrupt is propagated to INT pad only when it is enabled by setting bit `full_en`='1'. Latching mode configuration bit `int_latch` selects whether the interrupt status or condition is propagated to the INT pad.

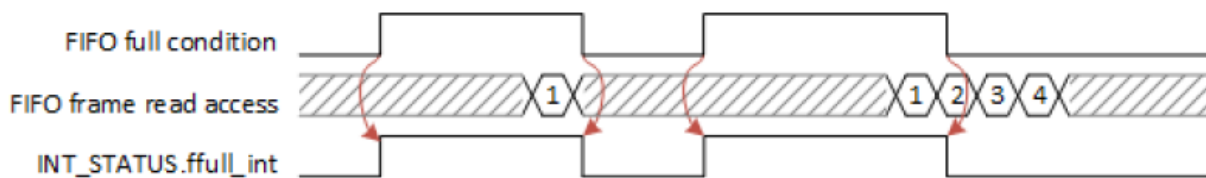

Figure 9: FIFO full interrupt, non-latched, with reads from FIFO

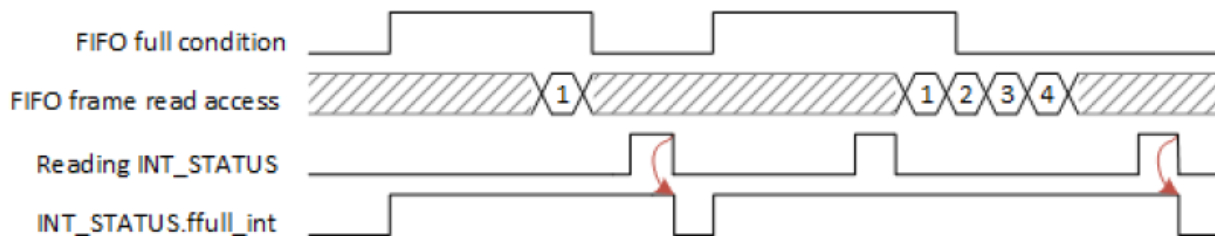

Figure 10: FIFO full interrupt, latched, with reads from FIFO

3.7.5.3. Data ready

Data ready interrupt status `int_status.drdy` is asserted after a pressure and temperature measurement ends and conversion results are stored to the data registers and to the FIFO. The status of the interrupt can be read back through the `drdy` bit. The data ready interrupt is propagated to INT pad when it is enabled by setting `drdy_en`='1'. Interrupt status is cleared by reading `drdy` bit high '1'. Data ready INT pad contribution is cleared automatically 2.5 ms after the interrupt assertion in the non-latched mode (`int_latch`='0').

Corner cases:

- If data ready interrupt is changed from latched to non-latched mode (`int_latched` changed from '1' to '0') after the interrupt was already asserted; timer is not running and it is not starting during the ongoing measurement, self-clearing does not happen. Timer is starting when next data ready comes.
- If data ready is changed to be propagated to INT pad (`drdy_int` changed from '0' to '1') after the interrupt was already asserted; data ready INT pad contribution remains '0' until next data ready interrupt assertion.

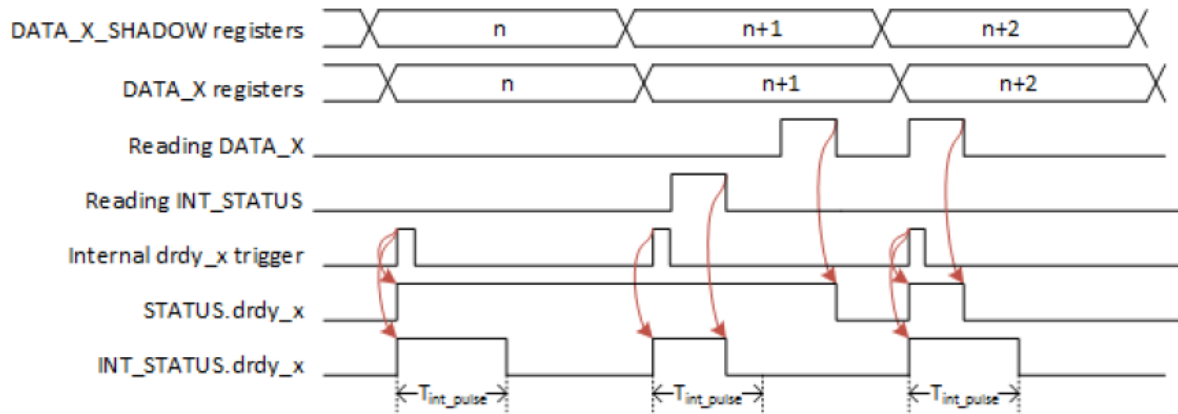

Figure 11: Data ready interrupt, non-latched mode, with read of data registers

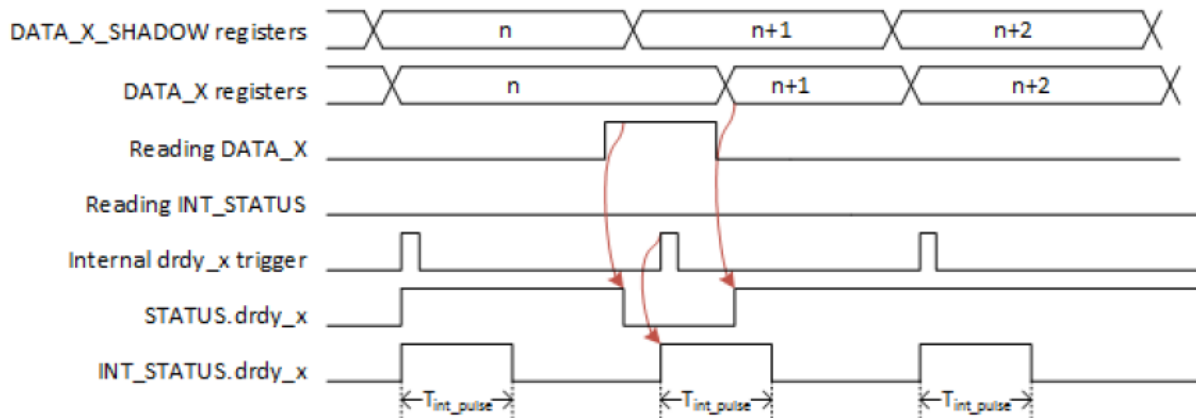

Figure 12: Data ready interrupt, non-latched mode, with read of data registers during register update

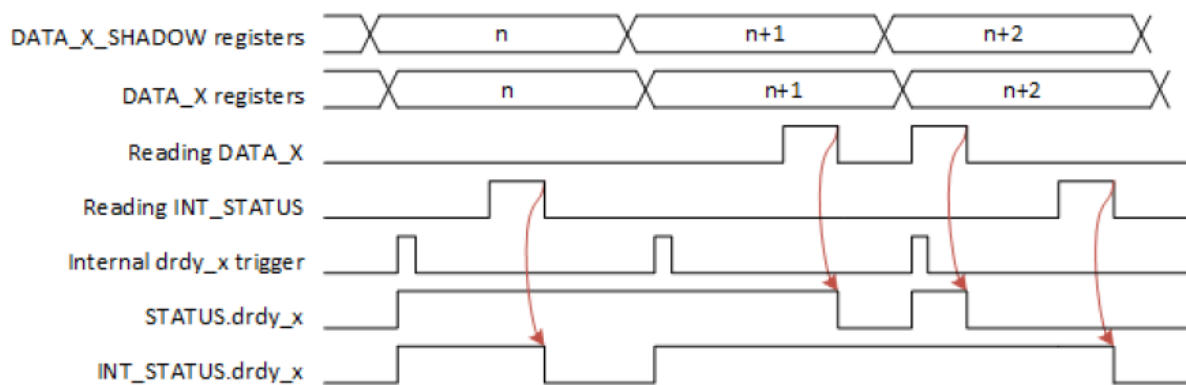

Figure 13: Data ready interrupt, latched mode, with read of data registers

3.8. Current consumption

The current consumption depends on ODR and oversampling setting. The values given below are normalized to an ODR of 1 Hz. The actual consumption at a given ODR can be calculated by multiplying the consumption in Table 20 with the ODR used. The actual ODR is defined either by the frequency at which the user sets forced measurements or by oversampling and sampling period settings in normal mode in Table 23.

Table 20: Current consumption

Oversampling setting	Pressure oversampling	Temperature oversampling	I _{DD} [μA] @ 1 Hz forced mode		
			Typ	Calculated Forced Mode	Max
Ultra low power	×1	×1	3.4	4.3	7.4
Low power	×2	×1	4.8	5.6	9.3
Standard resolution	×4	×1	7.8	8.2	12.8
High resolution	×8	×1	13.8	13.3	19.5
Ultra high resolution	×16	×2	26.2	24.3	33.5
highest resolution	×32	×2	46.4	45.0	59.2

3.9. Measurement timings

The rate at which measurements can be performed in forced mode depends on the oversampling settings *osr_t* and *osr_p*. Thus in normal mode, the measurement rate is determined by the sampling frequency *fsample*.

3.9.1. Measurement time

The following table explains the typical and maximum measurement time based on selected oversampling setting. The minimum achievable frequency is determined by the maximum measurement time.

Table 21: measurement time

Oversampling setting	Pressure oversampling	Temperature oversampling	Measurement time [ms]			Measurement rate [Hz]		
			Typ	Max	calculated min time in forced mode	Typ	Min	calculated max rate in forced mode
Ultra low power	×1	×1	5.5	5.7	4.9	181.8	155.6	202
Low power	×2	×1	7.5	8.7	6.9	133.3	114.6	144.1
Standard resolution	×4	×1	11.5	13.3	10.9	87.0	75.0	91.4
High resolution	×8	×1	19.5	22.5	18.9	51.3	44.4	52.8
Ultra high resolution	×16	×2	37.5	43.2	36.9	26.7	23.1	27.1
highest resolution	×32	×2			68.9			14.5

3.9.2. Measurement rate in forced mode and normal mode

In both forced mode and normal mode the pressure and temperature measurement duration follow the equation:

$$T_{conv} = 234\mu\text{s} + \text{press_en} \cdot (392\mu\text{s} + 2^{osr_p} \cdot 2000\mu\text{s}) + \text{temp_en} \cdot (313\mu\text{s} + 2^{osr_t} \cdot 2000\mu\text{s})$$

With:

T_{conv} = total conversion time in μs

press_en = "0" or "1", depending of the status of the press_en bit

temp_en = "0" or "1", depending of the status of the temp_en bit

2^{osr_p} = amount of pressure oversampling repetitions

2^{osr_t} = amount of temperature oversampling repetitions

Maximum possible readout frequency in forced mode (typical):

$$f_{max} = \frac{1}{T_{conv}[\mu\text{s}] \cdot 10^6}$$

Maximum possible readout frequency in normal mode:

$$\text{odr_sel} = \left\lceil \log_2 \left(\frac{200\text{Hz}}{f_{max}[\text{Hz}]} \right) \right\rceil$$

$$f_{max_normal_mode} = \frac{200\text{Hz}}{2^{\text{odr_sel}}}$$

3.10. Data readout from data registers

To read out data after a conversion, it is strongly recommended to use a burst read and not address every register individually. This will prevent a possible mix-up of bytes belonging to different measurements and reduce interface traffic. Data readout is done by starting a burst read from register press_xlsb to temp_msb . The data are read out in an unsigned 24-bit format both for pressure and for temperature.

The timing for data readout in forced mode should be done so that the maximum measurement times (see Sec. 3.9.1) are respected. In normal mode, readout can be done at a speed similar to the expected data output rate (see Sec. 3.9.2). After the uncompensated values of temperature and pressure have been read, the actual pressure and temperature need to be calculated using the compensation parameters stored in the device. The procedure is elaborated in Sec. 3.11.

3.10.1. Data register shadowing

In normal mode, measurement timing is not necessarily synchronized to readout. This means that new measurement results may become available while the user is reading the results from the previous measurement. In this case, shadowing is performed in order to guarantee data consistency. Shadowing will only work if all data registers are read in a single burst read. Therefore, the user must use burst reads if he does not synchronize data readout with the measurement cycle. Using several independent read commands may result in inconsistent data.

If a new measurement is finished and the data registers are still being read, the new measurement results are transferred into shadow data registers. The content of shadow registers is transferred into data registers as soon as the user ends the burst read, even if not all data registers were read. Reading across several data registers can therefore only be guaranteed to be consistent within one measurement cycle if a single burst read command is used. The end of the burst read is marked by the rising edge of CSB pin. After the end of the burst read, all user data registers are updated at once.

3.11. Output compensation

The BMP388 output consists of the ADC output values (including oversampling). However, each sensing element behaves differently, and thus in order to receive the most accurate physical values for temperature and pressure, compensation formulae have to be applied to the raw output values received from the sensor. The coefficients used for the compensation are stored into the devices' non-volatile memory (NVM) during production (see Table 22). For the compensation formula please see Appendix 9.

3.11.1. Memory Map Trimming Coefficients

Table 22: Trimming Coefficient listing in register map with size and sign attributes

Memory-ADR_Read [dec]	Memory-ADR_Read [hex]	Register content	Trimming Coefficient	Size	Sign
69	0x45	NVM_PAR_P11<7:0>	NVM_PAR_P11	8 Bit	signed
68	0x44	NVM_PAR_P10<7:0>	NVM_PAR_P10	8 Bit	signed
67	0x43	NVM_PAR_P9<15:8>	NVM_PAR_P9	16 Bit	signed
66	0x42	NVM_PAR_P9<7:0>			
65	0x41	NVM_PAR_P8<7:0>	NVM_PAR_P8	8 Bit	signed
64	0x40	NVM_PAR_P7<7:0>	NVM_PAR_P7	8 Bit	signed
63	0x3F	NVM_PAR_P6<15:8>	NVM_PAR_P6	16 Bit	unsigned
62	0x3E	NVM_PAR_P6<7:0>			
61	0x3D	NVM_PAR_P5<15:8>	NVM_PAR_P5	16 Bit	unsigned
60	0x3C	NVM_PAR_P5<7:0>			
59	0x3B	NVM_PAR_P4<7:0>	NVM_PAR_P4	8 Bit	signed
58	0x3A	NVM_PAR_P3<7:0>	NVM_PAR_P3	8 Bit	signed
57	0x39	NVM_PAR_P2<15:8>	NVM_PAR_P2	16 Bit	signed
56	0x38	NVM_PAR_P2<7:0>			
55	0x37	NVM_PAR_P1<15:8>	NVM_PAR_P1	16 Bit	signed
54	0x36	NVM_PAR_P1<7:0>			
53	0x35	NVM_PAR_T3<7:0>	NVM_PAR_T3	8 Bit	signed
52	0x34	NVM_PAR_T2<15:8>	NVM_PAR_T2	16 Bit	unsigned
51	0x33	NVM_PAR_T2<7:0>			
50	0x32	NVM_PAR_T1<15:8>	NVM_PAR_T1	16 Bit	unsigned
49	0x31	NVM_PAR_T1<7:0>			

4. Global memory map and register description

4.1. General remarks

All communication with the device is performed by reading and writing registers. All Registers have a width of 8 bits. There are several registers which are reserved; they should not be written to and no specific value is guaranteed when they are read. For details on the interface, consult chapter 5.

4.2. Datasheet Memory Map

The memory map is given in Table 23.

Table 23: BMP388 memory map

read/write			read only			write only			reserved		
Register Address	Register Name	Default Value	7	6	5	4	3	2	1	0	
0x7E	CMD	0x00	cmd								
0x7D	-	-	reserved								
...	-	-	reserved								
0x20	-	-	reserved								
0x1F	CONFIG	0x00	reserved				iir_filter			reserved	
0x1E	-	-	reserved								
0x1D	ODR	0x00	reserved			odr_sel					
0x1C	OSR	0x02	reserved		osr_t			osr_p			
0x1B	PWR_CTRL	0x00	reserved		mode		reserved		temp_en	press_en	
0x1A	IF_CONFIG	0x00	reserved					i2c_wdt_sel	i2c_wdt_en	spi3	
0x19	INT_CTRL	0x02	reserved	drdy_en	reserved	ffull_en	fwtm_en	int_latch	int_level	int_od	
0x18	FIFO_CONFIG_2	0x02	reserved			data_select		fifo_subsampling			
0x17	FIFO_CONFIG_1	0x02	reserved			fifo_temp_en	fifo_press_en	fifo_time_en	fifo_stop_on_full	fifo_mode	
0x16	FIFO_WATERM_1	0x00	reserved								fifo_water_mark_8
0x15	FIFO_WATERM_0	0x01	fifo_water_mark_7_0								
0x14	FIFO_DATA	0x00	fifo_data								
0x13	FIFO_LENGTH_1	0x00	reserved								fifo_byte_counter_8
0x12	FIFO_LENGTH_0	0x00	fifo_byte_counter_7_0								
0x11	INT_STATUS	0x00	reserved				drdy	reserved	ffull_int	fwm_int	
0x10	EVENT	0x01	reserved								por_detected
0x0F	SENSOR_TIME_3	0x00	sensor_time_31_24								
0x0E	SENSOR_TIME_2	0x00	sensor_time_23_16								

0x0D	SENSE RTIME 1	0x00	sensor_time_15_8					
0x0C	SENSE RTIME 0	0x00	sensor_time_7_0					
0x0B	-	-	reserved					
0x0A	-	-	reserved					
0x09	DATA 5	0x80	temp_23_16					
0x08	DATA 4	0x00	temp_15_8					
0x07	DATA 3	0x00	temp_7_0					
0x06	DATA 2	0x80	press_23_16					
0x05	DATA 1	0x00	press_15_8					
0x04	DATA 0	0x00	press_7_0					
0x03	STATUS	0x00	reserve d	drdy_te mp	drdy_pr ess	cmd_rd y	reserved	
0x02	ERR_R EG	0x00	reserved			conf_err	cmd_err	fatal_err
0x01	-	-	reserved					
0x00	CHIP_I D	0x50	chip_id_fixed			chip_id_nvm		

4.3. Register description

4.3.1. Register 0x00 “CHIP_ID”

The “CHIP_ID” register contains the chip identification code.

Table 24: Register 0x00 “CHIP_ID”

	Name	Description
Bit 7..0		Chip id.

4.3.2. Register 0x02 “ERR_REG”

Sensor Error conditions are reported in the “ERR_REG” register.

Table 25: Register 0x02 “ERR_REG”

	Name	Description
Bit 0	<i>fatal_err</i>	Fatal error
Bit 1	<i>cmd_err</i>	Command execution failed. Cleared on read.
Bit 2	<i>conf_err</i>	sensor configuration error detected. Cleared on read.

4.3.3. Register 0x03 “STATUS”

The Sensor Status Flags are stored in the “STATUS” register.

Table 26: Register 0x03 “STATUS”

	Name	Description
Bit 4	<i>cmd_rdy</i>	CMD decoder status. 0: Command in progress 1: Command decoder is ready to accept a new command
Bit 5	<i>drdy_press</i>	Data ready for pressure. It gets reset, when one pressure DATA register is read out
Bit 6	<i>drdy_temp</i>	Data ready for temperature sensor. It gets reset, when one temperature DATA register is read out

4.3.4. Register 0x04 .. 0x06 Pressure Data

The 24Bit pressure data is split and stored in three consecutive registers

- 0x04 “DATA_0”
- 0x05 “DATA_1”
- 0x06 “DATA_2”

Table 27: Pressure Data Registers

Register	0x06 DATA_2	0x05 DATA_1	0x04 DATA_0
Bit	7..0	7..0	7..0
name	PRESS_MSB_23_16	PRESS_LSB_15_8	PRESS_XLSB_7_0
Data	pressure data		

4.3.5. Register 0x07 .. 0x09 Temperature Data

The 24Bit temperature data is split and stored in three consecutive registers

- 0x07 “DATA_3”
- 0x08 “DATA_4”
- 0x09 “DATA_5”

Table 28: Temperature Data Registers

Register	0x09 DATA_5	0x08 DATA_4	0x07 DATA_3
Bit	7..0	7..0	7..0
name	TEMP_MSB_23_16	TEMP_LSB_15_8	TEMP_XLSB_7_0
Data	temperature data		

4.3.6. Register 0x0C .. 0x0E Sensor Time

The 24Bit sensor time is split and stored in three consecutive registers

- 0x0C “SENSORTIME_0”
- 0x0D “SENSORTIME_1”
- 0x0E “SENSORTIME_2”

Table 29: Sensor Time Registers

Register	0x0E SENSORTIME_2	0x0D SENSORTIME_1	0x0C SENSORTIME_0
Bit	7..0	7..0	7..0
name	sensor_time_23_16	sensor_time_15_8	sensor_time_7_0
Data	Sensor time		

4.3.7. Register 0x10 “EVENT”

The “EVENT” register contains the sensor status flags.

Table 30: Register 0x10 “EVENT”

	Name	Description
Bit 0	<i>por_detected</i>	‘1’ after device power up or softreset. Clear-on-read

4.3.8. Register 0x11 “INT_STATUS”

The “INT_STATUS” register shows interrupt status and is cleared after reading.

Table 31: Register 0x11 “INT_STATUS”

	Name	Description
Bit 0	<i>fwm_int</i>	FIFO Watermark Interrupt
Bit 1	<i>ffull_int</i>	FIFO Full Interrupt
Bit 3	<i>drdy</i>	data ready interrupt

4.3.9. Register 0x12 .. 0x13 “FIFO_LENGTH”

The FIFO byte counter indicates the current fill level of the FIFO buffer. Its size is 9 bit for 512 bytes and therefore split in two registers “FIFO_LENGTH_0” and “FIFO_LENGTH_1”.

Table 32: FIFO Length Split

Register	0x13 FIFO_LENGTH_1								0x12 FIFO_LENGTH_0							
Bit	7	6	5	4	3	2	1	0	7	6	5	4	3	2	1	0
name	fifo_byte_counter_8								fifo_byte_counter_7_0							

4.3.10. Register 0x14 “FIFO_DATA”

The “FIFO_DATA” is the data output register.

Table 33: Register 0x14 “FIFO_DATA”

	Name	Description
Bit 7..0	<i>fifo_data</i>	FIFO read data.

4.3.11. Register 0x15 .. 0x16 FIFO Watermark

The FIFO Watermark size is 9 Bit and therefore written to the FIFO_WTM_0 and FIFO_WTM_1 registers.

Table 34: FIFO Watermark Register Overview

Register	0x16 FIFO_WTM_1								0x15 FIFO_WTM_0							
Bit	7	6	5	4	3	2	1	0	7	6	5	4	3	2	1	0
name	<i>fifo_water_mark_8</i>								<i>fifo_water_mark_7_0</i>							

4.3.12. Register 0x17 “FIFO_CONFIG_1”

The “FIFO_CONFIG_1” register contains the FIFO frame content configuration.

Table 35: Register 0x17 “FIFO_CONFIG_1”

	Name	Description
Bit 0	<i>fifo_mode</i>	Enables or disables the FIFO 0 disable 1 enable FIFO mode
Bit 1	<i>fifo_stop_on_full</i>	Stop writing samples into FIFO when FIFO is full. 0 disable do not stop writing to FIFO when full 1 enable Stop writing into FIFO when full.
Bit 2	<i>fifo_time_en</i>	Return sensortime frame after the last valid data frame. 0 disable do not return sensortime frame 1 enable return sensortime frame
Bit 3	<i>fifo_press_en</i>	Store pressure data in FIFO 0 disable no pressure data is stored 1 enable pressure data is stored
Bit 4	<i>fifo_temp_en</i>	Store temperature data in FIFO 0 disable no temperature data is stored 1 enable temperature data is stored

4.3.13. Register 0x18 “FIFO_CONFIG_2”

The “FIFO_CONFIG_2” register extends the FIFO_CONFIG_1 register.

Table 36: Register 0x18 “FIFO_CONFIG_2”

	Name	Description
Bit 2..0	<i>fifo_subsampling</i>	FIFO downsampling selection for pressure and temperature data, factor is $2^{\text{fifo_subsampling}}$
Bit 4..3	<i>data_select</i>	for pressure and temperature, select data source 0 unfiltered data (compensated or uncompensated) 1 filtered data (compensated or uncompensated) 01 10 reserved, same as for “unfilt”

4.3.14. Register 0x19 “INT_CTRL”

Interrupt configuration can be set in the “INT_CTRL” register. It affects INT_STATUS registers and the INT pin.

Table 37: Register 0x19 “INT_CTRL”

	Name	Description
Bit 0	<i>int_od</i>	Configure output: open-drain or push-pull 0 push-pull 1 open-drain
Bit 1	<i>int_level</i>	level of INT pin 0 active_low 1 active_high
Bit 2	<i>int_latch</i>	Latching of interrupts for INT pin and INT_STATUS register 0 disabled 1 enabled
Bit 3	<i>fwtm_en</i>	enable FIFO watermark reached interrupt for INT pin and INT_STATUS. 0 disabled 1 enabled
Bit 4	<i>ffull_en</i>	enable Fifo full interrupt for INT pin and INT_STATUS 0 disabled 1 enabled
Bit 6	<i>drdy_en</i>	enable temperature / pressure data ready interrupt for INT pin and INT_STATUS 0 disabled 1 enabled

The “IF_CONF” register controls the the serial interface settings.

Table 38: Register 0x1A “IF_CONF”

	Name	Description
Bit 0	<i>spi3</i>	Configure SPI Interface Mode for primary interface 0 spi4 SPI 4-wire mode 1 spi3 SPI 3-wire mode
Bit 1	<i>i2c_wdt_en</i>	Enable for the I2C Watchdog timer, backed by NVM 0 disabled Watchdog disabled 1 enabled Watchdog enabled
Bit 2	<i>i2c_wdt_sel</i>	Select timer period for I2C Watchdog , backed by NVM 0 wdt_short I2C watchdog timeout after 1.25 ms 1 wdt_long I2C watchdog timeout after 40 ms

4.3.15. Register 0x1B “PWR_CTRL”

The “PWR_CTRL” register enables or disables pressure and temperature measurement. Although, the measurement mode can be set here.

Table 39: Register 0x1B “PWR_CTRL”

	Name	Description
Bit 0	<i>press_en</i>	0 press_off Disables the pressure sensor. 1 press_on Enables the pressure sensor.
Bit 1	<i>temp_en</i>	0 temp_off Disables the temperature sensor. 1 temp_on Enables the temperature sensor.
Bit 5..4	<i>mode</i>	0 sleep mode 01/01 forced mode 11 normal mode

4.3.16. Register 0x1C “OSR”

The “OSR” register controls the oversampling settings for pressure and temperature measurements.

Table 40: Register 0x1C “OSR”

	Name	Description
Bit 2..0	<i>osr_p</i>	Oversampling setting pressure measurement 000 x1 no oversampling. 001 x2 x2 oversampling. 010 x4 x4 oversampling. 011 x8 x8 oversampling. 100 x16 x16 oversampling. 101 x32 x32 oversampling.
Bit 5..3	<i>osr4_t</i>	Oversampling setting temperature measurement 000 x1 no oversampling 001 x2 x2 oversampling 010 x4 x4 oversampling 011 x8 x8 oversampling 100 x16 x16 oversampling 101 x32 x32 oversampling

4.3.17. Register 0x1D “ODR”

The “ODR” register set the configuration of the output data rates by means of setting the 36subdivision/subsampling.

Table 41: Register 0x1D “ODR”

	Name	Description
Bit 4..0	<i>odr_sel</i>	subdivision factor for pressure and temperature measurements is 2^{value} . Allowed values are 0..17. Other values are saturated at 17.

Table 42: Control Settings settings for *odr_sel*

<i>odr_sel</i>	prescaler	Name	Description	Sampling Period
0x00	1	ODR_200	ODR 200Hz	5 ms
0x01	2	ODR_100	ODR 100Hz	10 ms
0x02	4	ODR_50	ODR 50Hz	20 ms
0x03	8	ODR_25	ODR 25Hz	40 ms
0x04	16	ODR_12p5	ODR 25/2Hz	80 ms
0x05	32	ODR_6p25	ODR 25/4Hz	160 ms
0x06	64	ODR_3p1	ODR 25/8Hz	320 ms
0x07	127	ODR_1p5	ODR 25/16Hz	640 ms
0x08	256	ODR_0p78	ODR 25/32Hz	1.280 s
0x09	512	ODR_0p39	ODR 25/64Hz	2.560 s
0x0A	1024	ODR_0p2	ODR 25/128Hz	5.120 s
0x0B	2048	ODR_0p1	ODR 25/256Hz	10.24 s
0x0C	4096	ODR_0p05	ODR 25/512Hz	20.48 s
0x0D	8192	ODR_0p02	ODR 25/1024Hz	40.96 s
0x0E	16384	ODR_0p01	ODR 25/2048Hz	81.92 s
0x0F	32768	ODR_0p006	ODR 25/4096Hz	163.84 s
0x10	65536	ODR_0p003	ODR 25/8192Hz	327.68 s
0x11	131072	ODR_0p0015	ODR 25/16384Hz	655.36 s

4.3.18. Register 0x1F “CONFIG”

The “CONFIG” register controls the IIR filter coefficients.

Table 43: Register 0x1F “CONFIG”

	Name	Description
Bit 3..1	<i>iir_filter</i>	filter coefficient for IIR filter
		000 coef_0 filter coefficient is 0 -> bypass-mode
		001 coef_1 filter coefficient is 1
		010 coef_3 filter coefficient is 3
		011 coef_7 filter coefficient is 7
		100 coef_15 filter coefficient is 15
		101 coef_31 filter coefficient is 31
		110 coef_63 filter coefficient is 63
		111 coef_127 filter coefficient is 127

4.3.19. Register 0x30 .. 0x57 “calibration data”

The overview over the calibration data can be found in Chapter 3.11.1.

4.3.20. Register 0x7E “CMD”

The available commands of the “CMD” register are listed below.

Table 44: Register 0x7E “CMD”

	Name	Description
Bit 7..0	<i>cmd</i>	All Available commands (Note: Register will always read as 0x00)

Table 45: available cmd commands listed below

Value	Name	Description
0x00	<i>nop</i>	reserved. No command.
0x34	<i>extmode_en_middle</i>	see <i>extmode_en_last</i>
0xB0	<i>fifo_flush</i>	Clears all data in the FIFO, does not change FIFO_CONFIG registers
0xB6	<i>softreset</i>	Triggers a reset, all user configuration settings are overwritten with their default state

5. Digital interfaces

The BMP388 supports the I²C and SPI digital interfaces; it acts as a slave for both protocols. The I²C interface supports the standard, fast and high speed modes. The SPI interface supports both SPI mode '00' (CPOL = CPHA = '0') and mode '11' (CPOL = CPHA = '1') in 4-wire and 3-wire configuration.

The following transactions are supported:

- Single byte write
- Multiple byte write (using pairs of register addresses and register data)
- Single byte read
- Multiple byte read (using a single register address which is auto-incremented)

5.1. Interface selection

Interface selection is done automatically based on CSB (chip select) status. If CSB is connected to V_{DDIO}, the I²C interface is active. If CSB is pulled down, the SPI interface is activated. After CSB has been pulled down once (regardless of whether any clock cycle occurred), the I²C interface is disabled until the next power-on-reset. This is done in order to avoid inadvertently decoding SPI traffic to another slave as I²C data. Since power-on-reset is only executed when both V_{DD} and V_{DDIO} are established, there is no risk of incorrect protocol detection due to power-up sequence used. However, if I²C is to be used and CSB is not directly connected to V_{DDIO} but rather through a programmable pin, it must be ensured that this pin already outputs the V_{DDIO} level during power-on-reset of the device. If this is not the case, the device will be locked in SPI mode and not respond to I²C commands.

5.2. I²C Interface

The I²C slave interface is compatible with Philips I²C Specification Revision 6 (April 2014). For detailed timings refer to Table 47. All modes (standard, fast, high speed) are supported. SDA and SCL are not pure open-drain. Both pads contain ESD protection diodes to V_{DDIO} and GND.

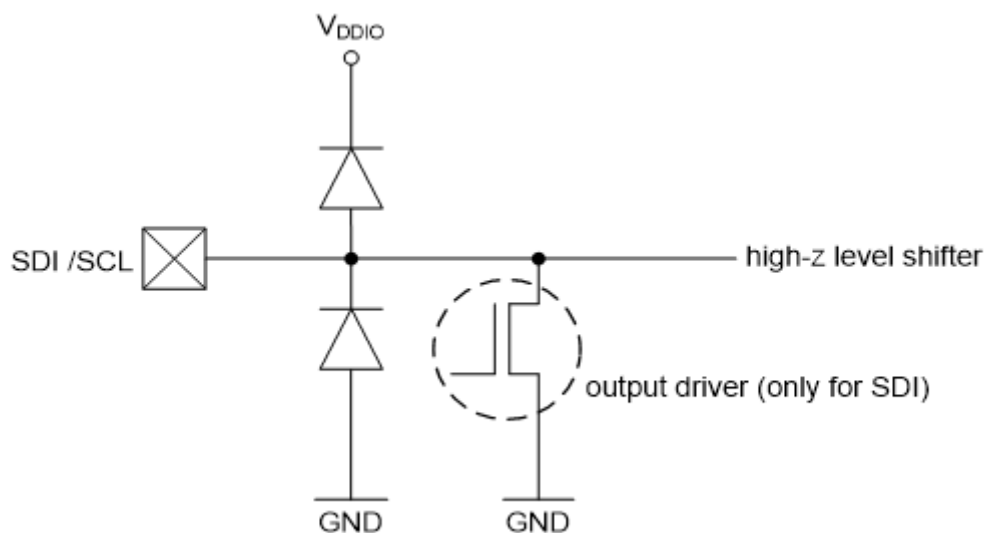

Figure 14: SDI/SCK ESD drawing

The 7-bit device address is 111011x. The 6 MSB bits are fixed. The last bit is changeable by SDO value and can be changed during operation. Connecting SDO to GND results in slave address 1110110 (0x76); connection it to V_{DDIO} results in slave address 1110111 (0x77), which is the same as BMP180's I²C address. The SDO pin cannot be left floating; if left floating, the I²C address will be undefined.

The I²C interface uses the following pins:

- SCK: serial clock (SCL)
- SDI: data (SDA)
- SDO: Slave address LSB (GND = '0', V_{DDIO} = '1')

The CSB is not used and is left open. SDI is bi-directional with open drain to VSS: it must be externally connected to V_{DDIO} via a pull up resistor. Refer to chapter 6 for connection instructions.

The following abbreviations will be used in the I²C protocol figures:

- S Start
- P Stop
- ACKS Acknowledge by slave
- ACKM Acknowledge by master
- NACKM Not acknowledge by master

5.2.1. I²C write

Writing is done by sending the slave address in write mode (RW = '0'), resulting in slave address 111011X0 ('X' is determined by state of SDO pin). Then the master sends pairs of register addresses and register data. The transaction is ended by a stop condition. This is depicted in Figure 15.

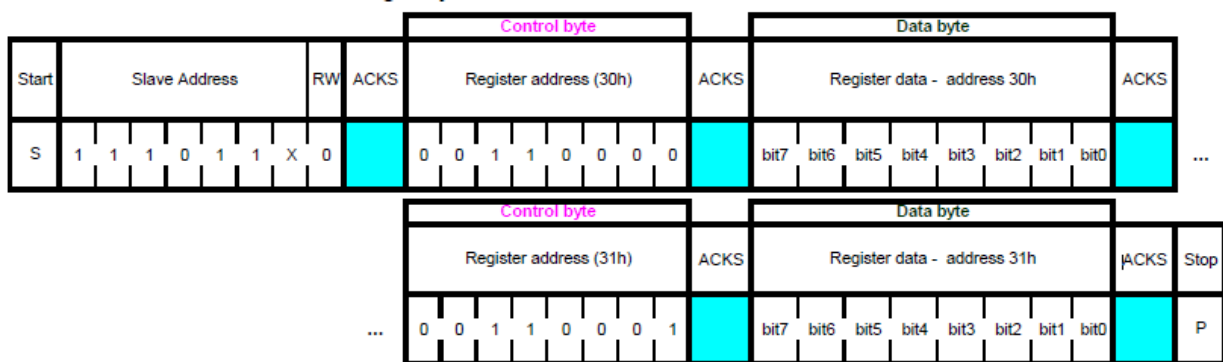

Figure 15: I²C write

5.2.2. I²C read

To be able to read registers, first the register address must be sent in write mode (slave address 111011X0). Then either a stop or a repeated start condition must be generated. After this the slave is addressed in read mode (RW = '1') at address 111011X1, after which the slave sends out data from auto-incremented register addresses until a NOACKM and stop condition occurs. This is depicted in Figure 16, where two bytes are read from register 0x05 and 0x06.

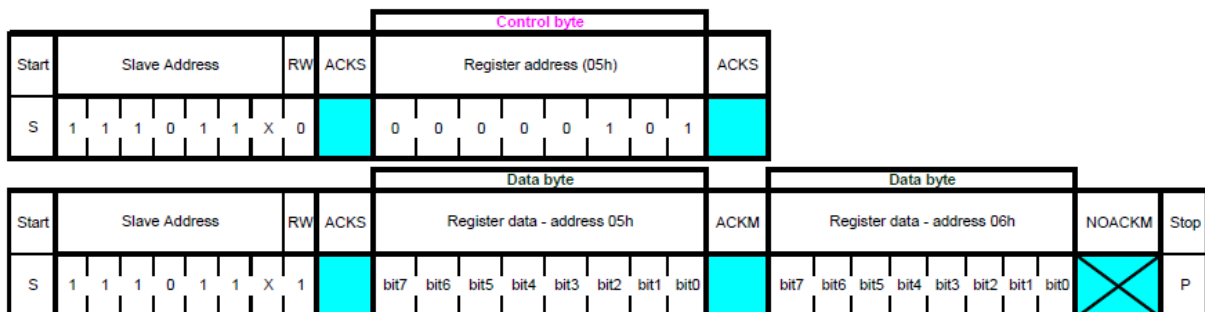

Figure 16: I²C multiple byte read

5.3. SPI interface

The SPI interface is compatible with SPI mode '00' (CPOL = CPHA = '0') and mode '11' (CPOL = CPHA = '1'). The automatic selection between mode '00' and '11' is determined by the value of SCK after the CSB falling edge.

The SPI interface has two modes: 4-wire and 3-wire. The protocol is the same for both. The 3-wire mode is selected by setting *spi3*='1' in register "IF_CONF[0]" (see 4.3.13). The pad SDI is used as a data input/output pad in 3-wire mode.

The SPI interface uses the following pins:

- CSB: chip select, active low
- SCK: serial clock
- SDI: serial data input; data input/output in 3-wire mode
- SDO: serial data output; hi-Z in 3-wire mode

Refer to chapter 6 for connection instructions.

CSB is active low and has an integrated pull-up resistor. Data on SDI is latched by the device at SCK rising edge and SDO is changed at SCK falling edge. Communication starts when CSB goes to low and stops when CSB goes to high; during these transitions on CSB, SCK must be stable. The SPI protocol is shown in Figure 17.

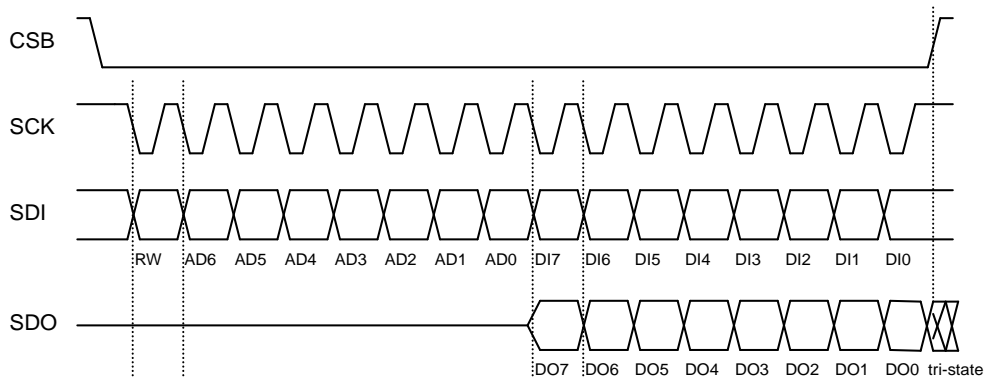

Figure 17: SPI protocol (shown for mode '11' in 4-wire configuration)

In SPI mode, only 7 bits of the register addresses are used; the MSB of register address is not used and replaced by a read/write bit (RW = '0' for write and RW = '1' for read).

Example: address 0xF7 is accessed by using SPI register address 0x77. For write access, the byte 0x77 is transferred, for read access, the byte 0xF7 is transferred.

5.3.1. SPI write

Writing is done by lowering CSB and sending pairs control bytes and register data. The control bytes consist of the SPI register address (= full register address without bit 7) and the write command (bit7 = RW = '0'). Several pairs can be written without raising CSB. The transaction is ended by a raising CSB. The SPI write protocol is depicted in Figure 18.

Figure 18: 4 wire SPI sequence

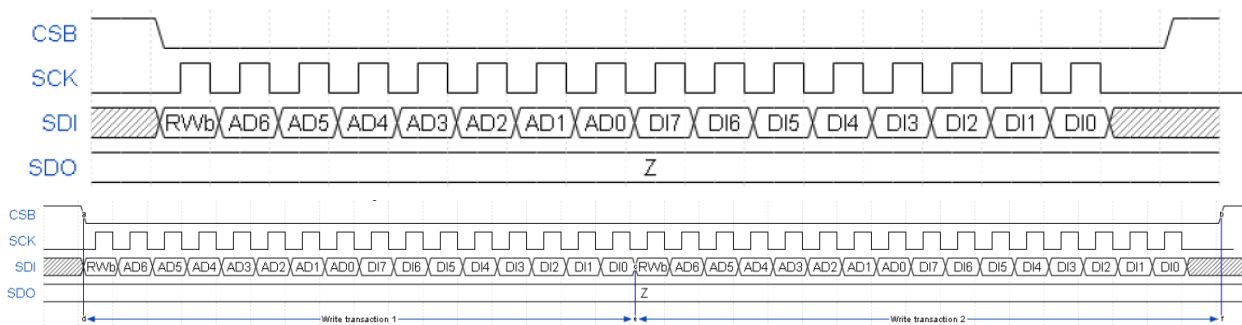

Figure 19: SPI multiple write

5.3.2. SPI read

Reading is done by lowering CSB and first sending one control byte. The control bytes consist of the SPI register address (= full register address without bit 7) and the read command (bit 7 = RW = '1'). After writing the control byte, one dummy byte is sent and there after data bytes. The register address is automatically incremented. The SPI read protocol is shown in Figure 20.

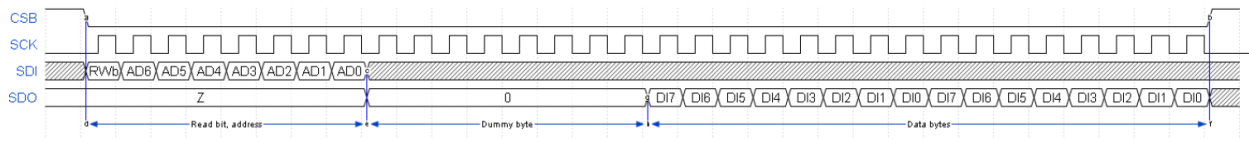

Figure 20: SPI multiple byte read

5.4. Interface parameter specification

5.4.1. General interface parameters

The general interface parameters are given in the table below:

Table 46: interface parameters

Parameter	Symbol	Condition	Min	Typ	Max	Units
Input – low level	Vil	SCK, SDI and CSB			0 V _{DDIO}	V
Input – high level	Vih	SCK, SDI and CSB	1 V _{DDIO}			V
Output – low level	Vol	SDI, SDO and INT, iol=3 mA			2 V _{DDIO}	V
Output – high level	Voh	SDI, SDO and INT ioh=1 mA	3 V _{DDIO}			V
CSB Pull-up resistor	Rcsb	Internal pull-up resistance to V _{DDIO}	75	100	125	kΩ
I ² C bus load capacitor	Cb	On SDI and SCK			400	pF

5.4.2. I²C timings

For I²C timings, the following abbreviations are used:

- “S&F mode” = standard and fast mode
- “HS mode” = high speed mode
- Cb = bus capacitance on SDA line

All other naming refers to I²C specification 2.1 (January 2000).

The I²C timing diagram is shown in

Figure 21. The corresponding values are given in Table 47.

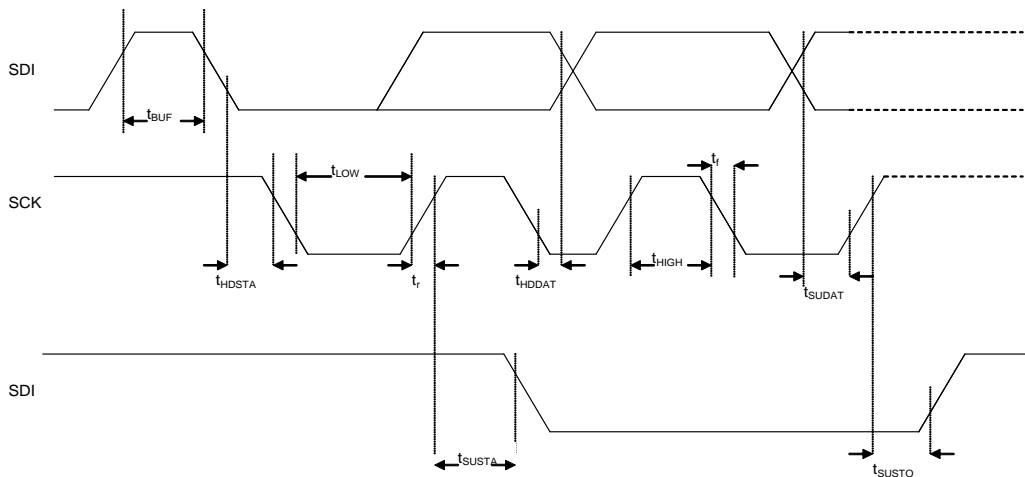

Figure 21: I²C timing diagram

Table 47: I²C timings

Parameter	Symbol	Condition	Min	Typ	Max	Units
SCK frequency	Fi2c			400	3400	kHz
SDI input setup time	$t_{SU,DATA}$	S&F Mode	160			ns
		HS mode	30			ns
SDI output hold time	$t_{HD,DATA}$	S&F Mode, $C_b \leq 100$ pF	80			ns
		S&F Mode, $C_b \leq 400$ pF	90			ns
		HS mode, $C_b \leq 100$ pF	18			ns
		HS mode, $C_b \leq 400$ pF	24			ns
SCK low pulse	t_{LOW}	HS mode, $C_b \leq 100$ pF $V_{DDIO} = 1.62$ V	160			ns
SCK low pulse	t_{LOW}	HS mode, $C_b \leq 100$ pF $V_{DDIO} = 1.2$ V	210			ns

The above-mentioned I²C specific timings correspond to the following internal added delays:

- Input delay between SDI and SCK inputs: SDI is more delayed than SCK by typically 120 ns in Standard and Fast Modes and by typically 20 ns in High Speed Mode.
- Output delay from SCK falling edge to SDI output propagation is typically 140 ns in Standard and Fast Modes and typically 70 ns in High Speed Mode.

5.4.3. SPI timings

The SPI timing diagram is in Figure 22, while the corresponding values are given in Table 48. All timings apply both to 4- and 3-wire SPI.

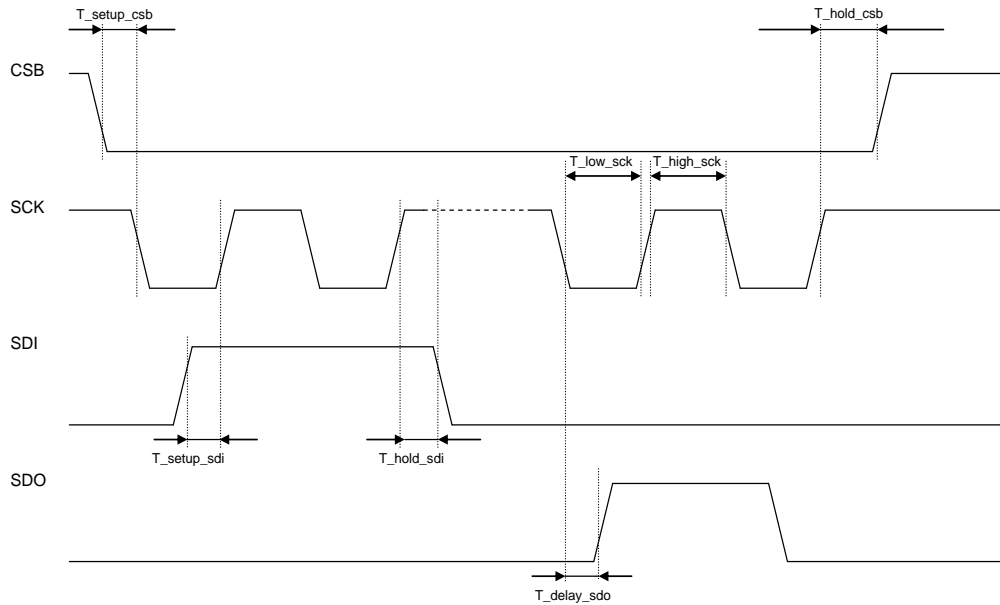

Figure 22: SPI timing diagram

Table 48: SPI timings

Parameter	Symbol	Condition	Min	Typ	Max	Units
SPI clock input frequency	F_spi		0		10	MHz
SCK low pulse	T_low_sck		20			ns
SCK high pulse	T_high_sck		20			ns
SDI setup time	T_setup_sdi		20			ns
SDI hold time	T_hold_sdi		20			ns
SDO output delay	T_delay_sdo	25pF load, V _{DDIO} =1.6V min			30	ns
SDO output delay	T_delay_sdo	25pF load, V _{DDIO} =1.2V min			40	ns
CSB setup time	T_setup_csb		20			ns
CSB hold time	T_hold_csb		20			ns

6. Pin-out and connection diagram

6.1. Pin-out

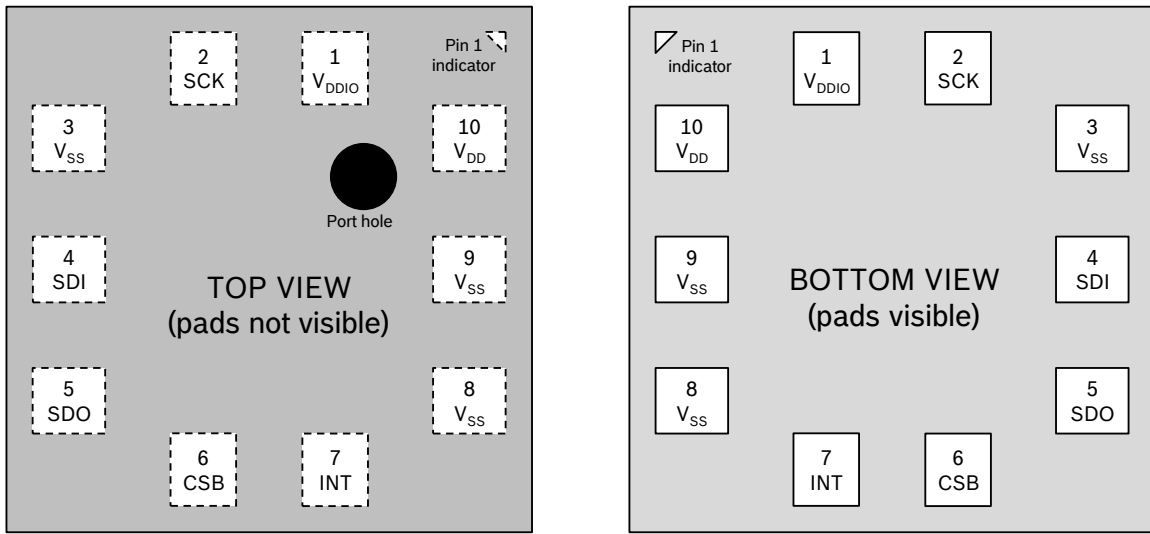

Figure 23: Pin-out top and bottom view

Table 49: Pin description

Pin	Name	I/O Type	Description	Connect to	
				SPI 4W	SPI 3W
1	VDDIO	Supply	Digital interface supply	V _{DDIO}	
2	SCK	In	Serial clock input	SCK	SCK
3	VSS	Supply	Ground	GND	
4	SDI	In/Out	Serial data input	SDI	SDI/SDO
5	SDO	In/Out	Serial data output	SDO	DNC
6	CSB	In	Chip select	CSB	CSB
7	INT	Out	INT output	host INT input or DNC ⁷	
8	VSS	Supply	Ground	GND	
9	VSS	Supply	Ground	GND	
10	VDD	Supply	Analog supply	V _{DD}	

⁷ GND connection in legacy BMP282 systems is allowed, as long as the IRQ pin is not activated

6.2. Connection diagram 3/4-wire SPI

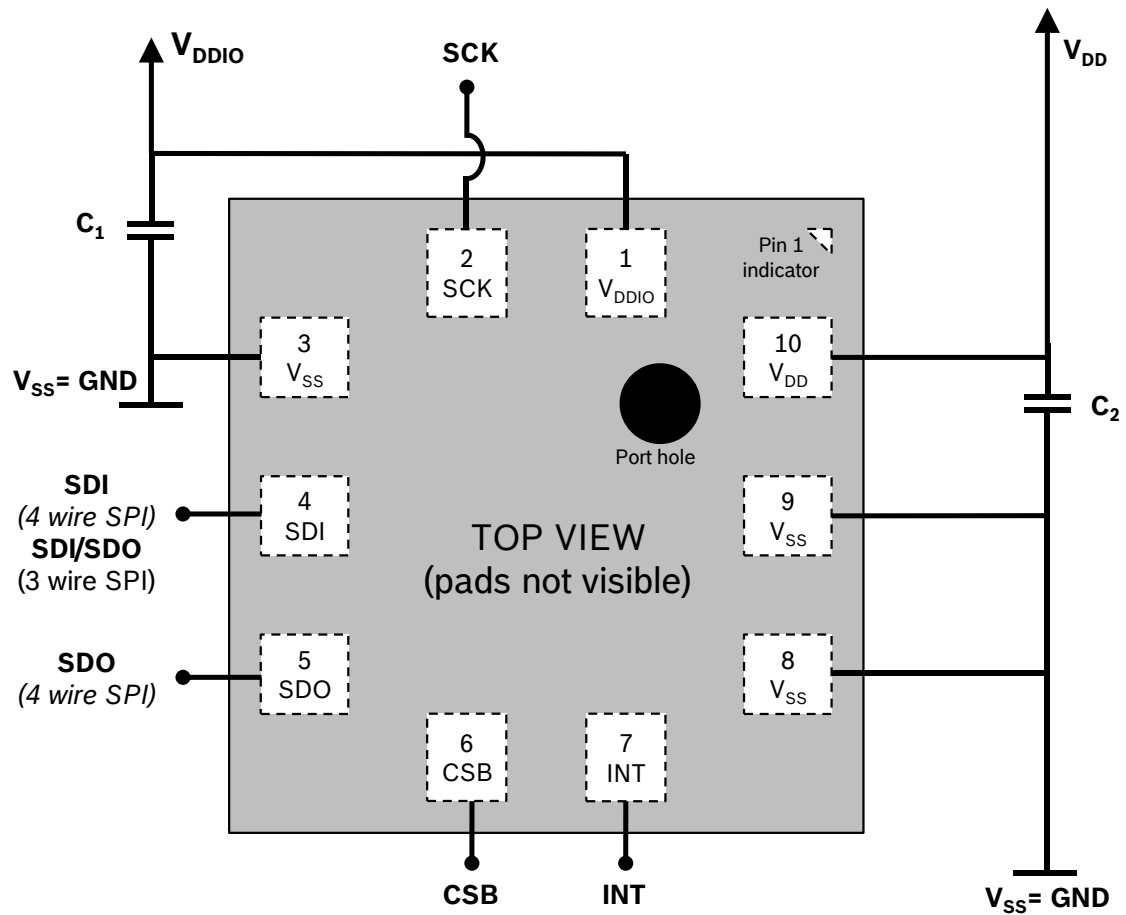

Figure 24: 3 and 4-wire SPI connection diagram (Pin1 marking indicated).

Note: the recommended value for C₁, C₂ is 100 nF.

6.3. Connection diagram I²C

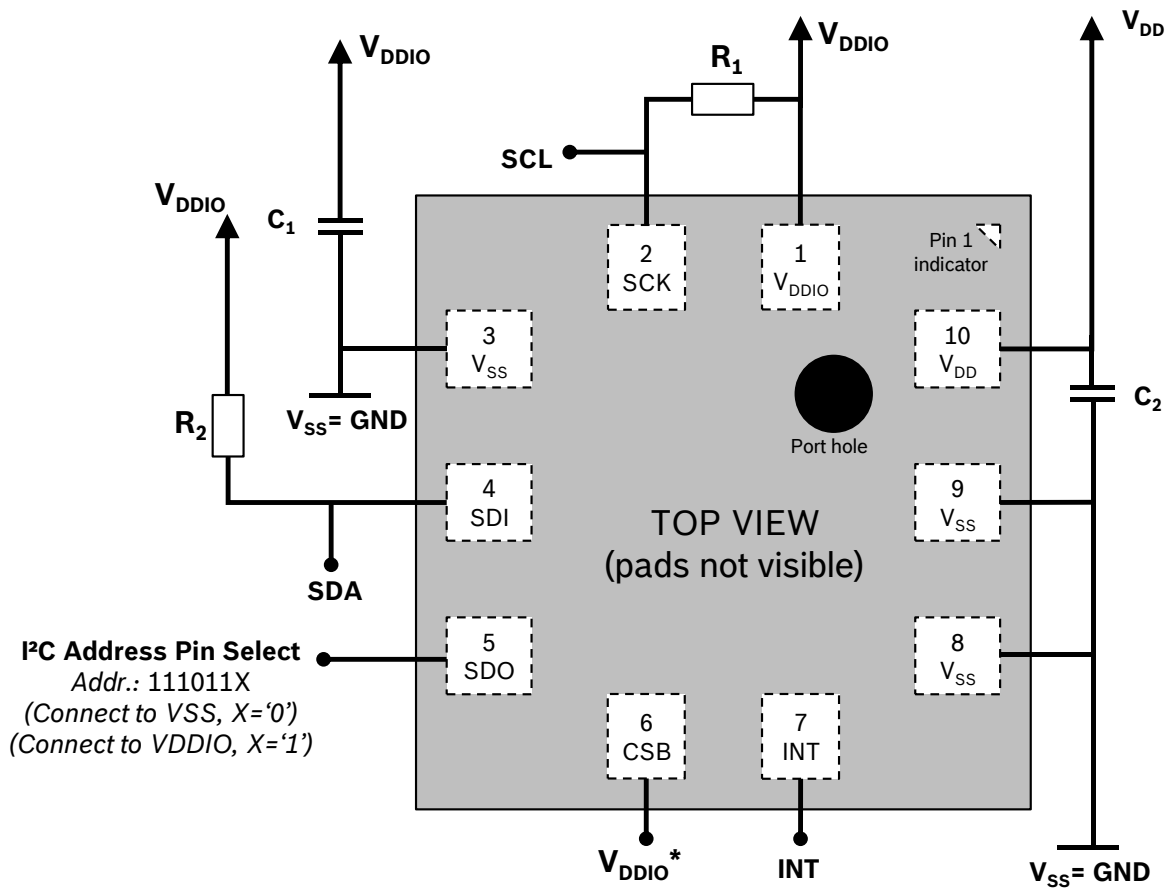

Figure 25: I²C connection diagram (Pin1 marking indicated)

Notes:

- the recommended value for C₁, C₂ is 100 nF and for R₁, R₂ is 4.7 kΩ.
- *: It is recommended to connect the BMP388 CSB pin to programmable pin which drives V_{DDIO} at POR of device (see Chapter 5.1)

7. Package, reel and environment

7.1. Outline dimensions

The sensor housing is an 10-pin metal-lid LGA 2.0×2.0×0.75 mm³ package (typ.). Its dimensions are depicted in Figure 26.

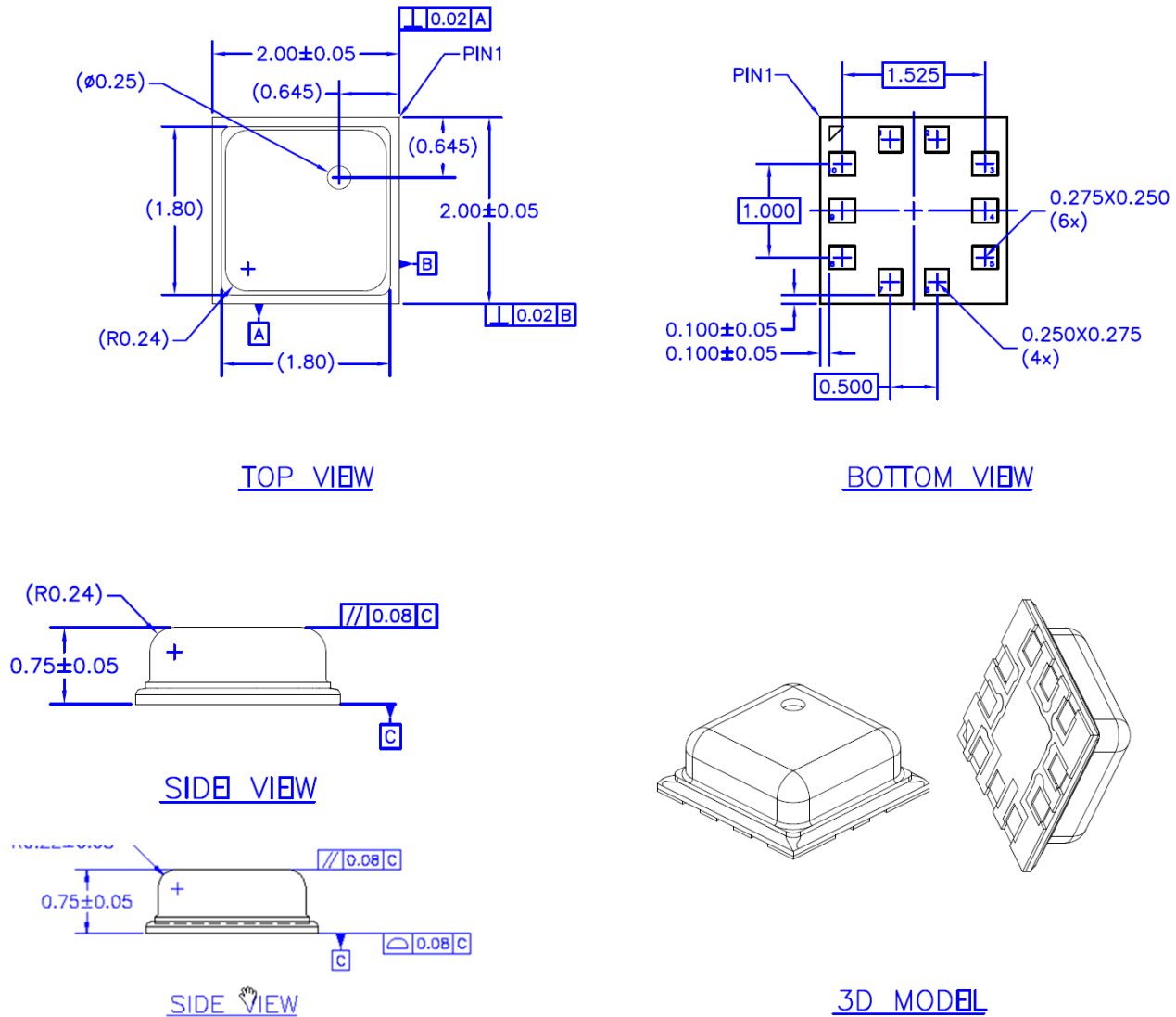

Figure 26: Package outline dimensions BMP388 for top, bottom, side and 3D view

Note: General tolerances are $\pm 50 \mu\text{m}$ (linear) and $\pm 1^\circ$ (angular)

7.2. Landing pattern

Bosch Sensortec suggests the BMP388 outline Dimensions (see 7.1- bottom view) as landing pattern.

7.3. Marking

7.3.1. Mass production samples

Table 50: Marking of mass production samples

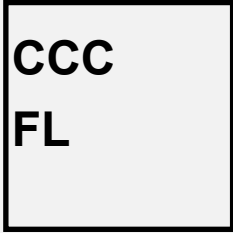
Labeling	Name	Symbol	Remark
	Lot Counter ID	CCC	3 alphanumeric digits, variable to generate mass production trace code
	Product number	F	alphanumeric digit to identify product type, "F" is associated with the product BMP388 (part number 0 273 300 511)
	Sub-con ID	L	1 alphanumeric digit, variable to identify sub-con
	Orientation marker	●	Vent hole

7.3.2. Engineering samples

Table 51: Marking of engineering samples

Labeling	Name	Symbol	Remark
	Eng. Sample ID	R	1 alphanumeric digit, fixed identification of sample status R="A" or "C" or "F"
	Sample ID	XX	2 alphanumeric digit, variable identification of sample lot number
	Counter ID	CCC	2 or 3 alphanumeric digits, variable to generate trace-code
	Orientation marker	●	Vent hole

7.4. Soldering guidelines

The moisture sensitivity level of the BMP388 sensors corresponds to JEDEC Level 1, see also:

- IPC/JEDEC J-STD-020C “Joint Industry Standard: Moisture/Reflow Sensitivity Classification for non-hermetic Solid State Surface Mount Devices”
- IPC/JEDEC J-STD-033A “Joint Industry Standard: Handling, Packing, Shipping and Use of Moisture/Reflow Sensitive Surface Mount Devices”.

The sensor fulfils the lead-free soldering requirements of the above-mentioned IPC/JEDEC standard, i.e. reflow soldering with a peak temperature up to 260°C. The minimum height of the solder after reflow shall be at least 20 µm. This is required for good mechanical decoupling between the sensor device and the printed circuit board (PCB).

Profile Feature	Pb-Free Assembly
Average Ramp-Up Rate (T _{Smax} to T _p)	3° C/second max.
Preheat - Temperature Min (T _{Smin}) - Temperature Max (T _{Smax}) - Time (t _{Smin} to t _{Smax})	150 °C 200 °C 60-180 seconds
Time maintained above: - Temperature (T _L) - Time (t _L)	217 °C 60-150 seconds
Peak/Classification Temperature (T _p)	260 °C
Time within 5 °C of actual Peak Temperature (t _p)	20-40 seconds
Ramp-Down Rate	6 °C/second max.
Time 25 °C to Peak Temperature	8 minutes max.

Note 1: All temperatures refer to topside of the package, measured on the package body surface.

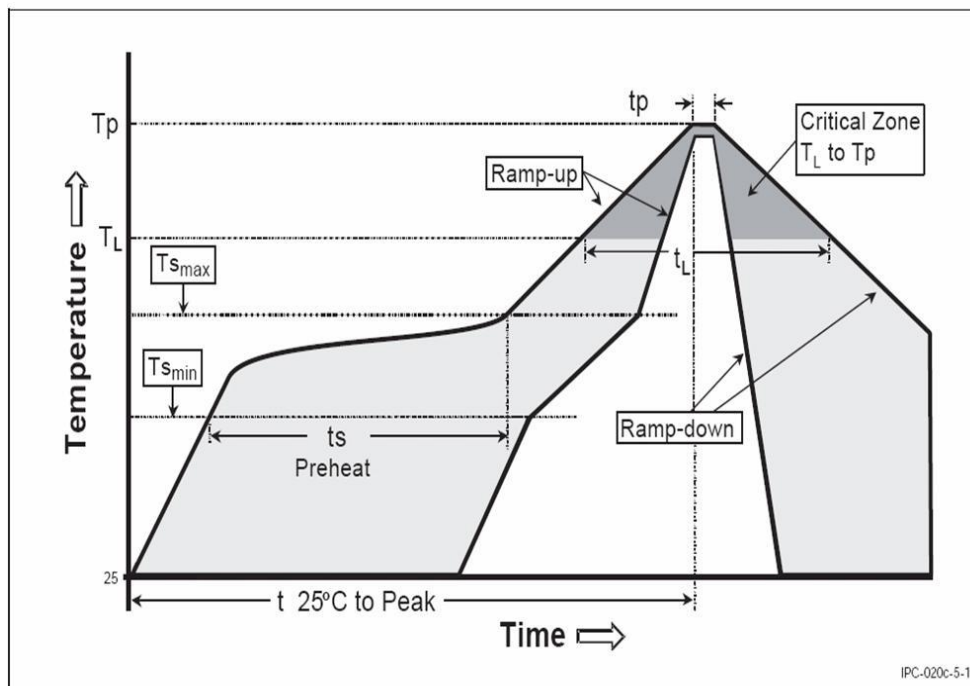

Figure 27: Soldering profile

7.5. Tape and reel specification

7.5.1. Dimensions

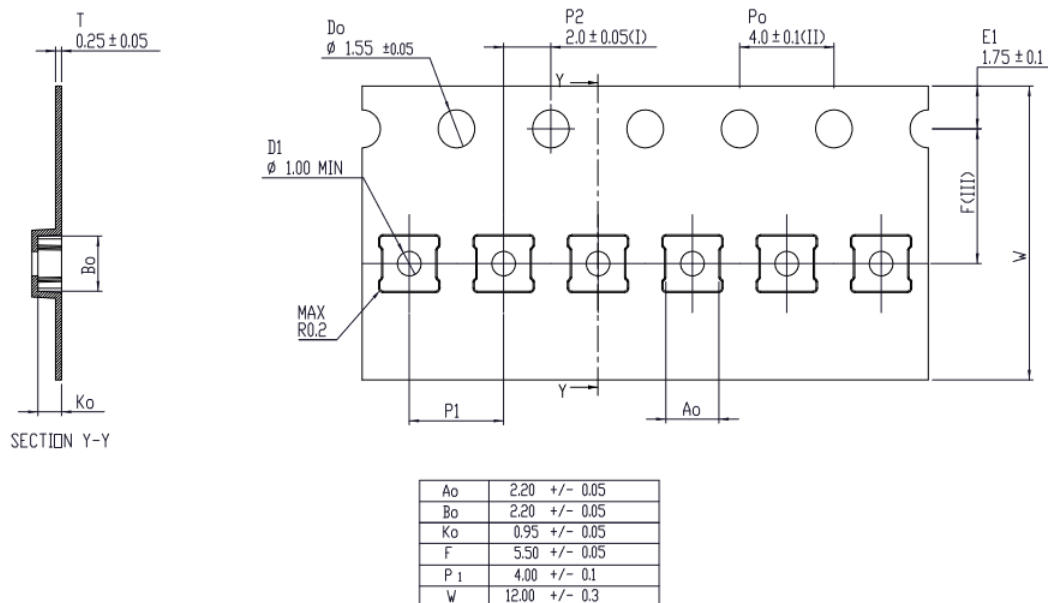

Figure 28: Tape and Reel dimensions

Quantity per reel: 10 kpcs.

7.5.2. Orientation within the reel

The orientation of the sensor placement inside the tape on reel can be found below.

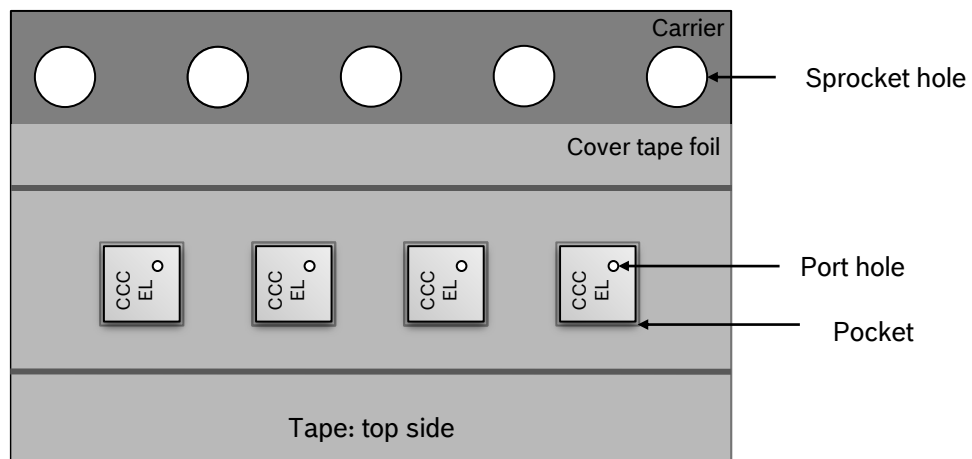

Figure 29: Orientation within tape

7.6. Mounting and assembly recommendations

In addition to “Handling, soldering & mounting instructions BMP38x”, the following recommendations should be taken into consideration when mounting a pressure sensor on a printed-circuit board (PCB):

- The clearance above the metal lid shall be 0.1mm at minimum.
- For the device housing appropriate venting needs to be provided in case the ambient pressure shall be measured.
- Liquids shall not come into direct contact with the device.
- During operation the sensor chip is sensitive to light, which can influence the accuracy of the measurement (photo-current of silicon). The position of the vent hole minimizes the light exposure of the sensor chip. Nevertheless, BST recommends to avoid the exposure of BMP388 to strong light sources.
- Soldering must not be done using vapor phase processes since the sensor might be damaged.

7.7. Environmental safety

7.7.1. RoHS

The BMP388 sensor meets the requirements of the EC restriction of hazardous substances (RoHS) directive, see also: Directive 2002/95/EC of the European Parliament and of the Council of 8 September 2011 on the restriction of the use of certain hazardous substances in electrical and electronic equipment.

7.7.2. Halogen content

The BMP388 is halogen-free. For more details on the analysis results please contact your Bosch Sensortec representative.

7.7.3. Internal package structure

Within the scope of Bosch Sensortec's ambition to improve its products and secure the mass product supply, Bosch Sensortec qualifies additional sources (e.g. 2nd source) for the LGA package of the BMP388.

While Bosch Sensortec took care that all of the technical packages parameters are described above are 100% identical for all sources, there can be differences in the chemical content and the internal structural between the different package sources.

However, as secured by the extensive product qualification process of Bosch Sensortec, this has no impact to the usage or to the quality of the BMP388 product.

8. Legal disclaimer

8.1. Engineering samples

Engineering Samples are marked with an asterisk (*) or € or €. Samples may vary from the valid technical specifications of the product series contained in this data sheet. They are therefore not intended or fit for resale to third parties or for use in end products. Their sole purpose is internal client testing. The testing of an engineering sample may in no way replace the testing of a product series. Bosch Sensortec assumes no liability for the use of engineering samples. The Purchaser shall indemnify Bosch Sensortec from all claims arising from the use of engineering samples.

8.2. Product use

Bosch Sensortec products are developed for the consumer goods industry. They may only be used within the parameters of this product data sheet. They are not fit for use in life-sustaining or safety-critical systems. Safety-critical systems are those for which a malfunction is expected to lead to bodily harm or significant property damage. In addition, they are not fit for use in products which interact with motor vehicle systems.

The resale and/or use of products are at the purchaser's own risk and his own responsibility. The examination of fitness for the intended use is the sole responsibility of the Purchaser.

The purchaser shall indemnify Bosch Sensortec from all third party claims arising from any product use not covered by the parameters of this product data sheet or not approved by Bosch Sensortec and reimburse Bosch Sensortec for all costs in connection with such claims.

The purchaser must monitor the market for the purchased products, particularly with regard to product safety, and inform Bosch Sensortec without delay of all safety relevant incidents.

8.3. Application examples and hints

With respect to any examples or hints given herein, any typical values stated herein and/or any information regarding the application of the device, Bosch Sensortec hereby disclaims any and all warranties and liabilities of any kind, including without limitation warranties of non-infringement of intellectual property rights or copyrights of any third party. The information given in this document shall in no event be regarded as a guarantee of conditions or characteristics. They are provided for illustrative purposes only and no evaluation regarding infringement of intellectual property rights or copyrights or regarding functionality, performance or error has been made.

9. Appendix: Computation formulae reference implementation

The code below gives a provides a C implementation of the compensation algorithms discussed in Sec. 3.10.

The struct BMP388_calib_data is a structure, that contains the calibration coefficients. And the t_lin variable that carries a temperature value over to the pressure compensation.

9.1. Calibration coefficient

The calibration coefficients are stored as described in Table 22. The compensation formula is implemented in floating point. Therefore the coefficient have to be converted into floating point numbers by the following formulas.

$$PAR_T1 = \frac{NVM_PAR_T1}{2^{-8}} \quad PAR_T2 = \frac{NVM_PAR_T2}{2^{30}} \quad PAR_T3 = \frac{NVM_PAR_T3}{2^{48}}$$

$$PAR_P1 = \frac{NVM_PAR_P1 - 2^{14}}{2^{20}} \quad PAR_P2 = \frac{NVM_PAR_P2 - 2^{14}}{2^{29}} \quad PAR_P3 = \frac{NVM_PAR_P3}{2^{32}}$$

$$PAR_P4 = \frac{NVM_PAR_P4}{2^{37}} \quad PAR_P5 = \frac{NVM_PAR_P5}{2^{-3}} \quad PAR_P6 = \frac{NVM_PAR_P6}{2^6}$$

$$PAR_P7 = \frac{NVM_PAR_P7}{2^8} \quad PAR_P8 = \frac{NVM_PAR_P8}{2^{15}} \quad PAR_P9 = \frac{NVM_PAR_P9}{2^{48}}$$

$$PAR_P10 = \frac{NVM_PAR_P10}{2^{48}} \quad PAR_P11 = \frac{NVM_PAR_P11}{2^{65}}$$

9.2. Temperature compensation

```
static float BMP388_compensate_temperature(uint32_t uncomp_temp, struct BMP388_calib_data *calib_data)
{
    float partial_data1;
    float partial_data2;

    partial_data1 = (float)(uncomp_temp - calib_data->par_t1);
    partial_data2 = (float)(partial_data1 * calib_data->par_t2);
    /* Update the compensated temperature in calib structure since this is
    * needed for pressure calculation */
    calib_data->t_lin = partial_data2 + (partial_data1 * partial_data1) * calib_data->par_t3;

    /* Returns compensated temperature */
    return calib_data->t_lin;
}
```

9.3. Pressure compensation

```

static float BMP388_compensate_pressure(uint32_t uncomp_press, struct BMP388_calib_data *calib_data)
{
    /* Variable to store the compensated pressure */
    float comp_press;
    /* Temporary variables used for compensation */
    float partial_data1;
    float partial_data2;
    float partial_data3;
    float partial_data4;
    float partial_out1;
    float partial_out2;
    /* Calibration data */

    partial_data1 = calib_data->par_p6 * calib_data->t_lin;
    partial_data2 = calib_data->par_p7 * (calib_data->t_lin * calib_data->t_lin);
    partial_data3 = calib_data->par_p8 * (calib_data->t_lin * calib_data->t_lin * calib_data->t_lin);
    partial_out1 = calib_data->par_p5 + partial_data1 + partial_data2 + partial_data3;

    partial_data1 = calib_data->par_p2 * calib_data->t_lin;
    partial_data2 = calib_data->par_p3 * (calib_data->t_lin * calib_data->t_lin);
    partial_data3 = calib_data->par_p4 * (calib_data->t_lin * calib_data->t_lin * calib_data->t_lin);
    partial_out2 = (float)uncomp_press *
        (calib_data->par_p1 + partial_data1 + partial_data2 + partial_data3);

    partial_data1 = (float)uncomp_press * (float)uncomp_press;
    partial_data2 = calib_data->par_p9 + calib_data->par_p10 * calib_data->t_lin;
    partial_data3 = partial_data1 * partial_data2;
    partial_data4 = partial_data3 + ((float)uncomp_press * (float)uncomp_press * (float)uncomp_press) * calib_data->par_p11;
    comp_press = partial_out1 + partial_out2 + partial_data4;

    return comp_press;
}

```

10. Document history and modification

Rev. No	Section	Description of modification/changes	Date
0.1		Document Creation	21.11.2016
0.2	7.4.2	Added 7.4.2 Orientation within the reel	13.03.2017
	1	Added min/max data for restricted datasheet	
0.3	7.1	Added warpage information	14.07.2017
0.4	1	Added min/max values and noise figures	18.10.2017
	3.4.4	Updated noise values	
	3.5	Updated filter settings for different use cases	
1.0		Final official version	15.01.2018
1.1	7.3.2	Change of laser marking definition	14.03.2018
1.1	1	Added missing sigma	25.04.2018
	3	Changed coefficient from 128 to 127	
	3.11.1	Change 0x3B register content to NVM_PAR_P4	
	4.3.11	Greyed out unused bits	
	3.4	Updated reference links	
	3.4.2	Updated header number	
	4.3.11	Changed watermark name	
	7.3.2	Updated marking of engineering samples	

Bosch Sensortec GmbH
Gerhard-Kindler-Straße 9
72770 Reutlingen / Germany

www.bosch-sensortec.com

Modifications reserved | Printed in Germany
Preliminary - specifications subject to change without notice
Document number: BST-BMP388-DS001-01
Revision_1.1_032018

Mouser Electronics

Authorized Distributor

Click to View Pricing, Inventory, Delivery & Lifecycle Information:

[Bosch:](#)

[BMP388](#)



Компания «ЭлектроПласт» предлагает заключение долгосрочных отношений при поставках импортных электронных компонентов на взаимовыгодных условиях!

Наши преимущества:

- Оперативные поставки широкого спектра электронных компонентов отечественного и импортного производства напрямую от производителей и с крупнейших мировых складов;
- Поставка более 17-ти миллионов наименований электронных компонентов;
- Поставка сложных, дефицитных, либо снятых с производства позиций;
- Оперативные сроки поставки под заказ (от 5 рабочих дней);
- Экспресс доставка в любую точку России;
- Техническая поддержка проекта, помощь в подборе аналогов, поставка прототипов;
- Система менеджмента качества сертифицирована по Международному стандарту ISO 9001;
- Лицензия ФСБ на осуществление работ с использованием сведений, составляющих государственную тайну;
- Поставка специализированных компонентов (Xilinx, Altera, Analog Devices, Intersil, Interpoint, Microsemi, Aeroflex, Peregrine, Syfer, Eurofarad, Texas Instrument, Miteq, Cobham, E2V, MA-COM, Hittite, Mini-Circuits, General Dynamics и др.);

Помимо этого, одним из направлений компании «ЭлектроПласт» является направление «Источники питания». Мы предлагаем Вам помощь Конструкторского отдела:

- Подбор оптимального решения, техническое обоснование при выборе компонента;
- Подбор аналогов;
- Консультации по применению компонента;
- Поставка образцов и прототипов;
- Техническая поддержка проекта;
- Защита от снятия компонента с производства.



Как с нами связаться

Телефон: 8 (812) 309 58 32 (многоканальный)

Факс: 8 (812) 320-02-42

Электронная почта: org@eplast1.ru

Адрес: 198099, г. Санкт-Петербург, ул. Калинина, дом 2, корпус 4, литера А.