

### Features

- Low Voltage Operation: 2.5 V
- Low Harmonics: < -65 dBc at +34 dBm & 1 GHz
- Low Insertion Loss: 0.65 dB @ 1 GHz
- High Isolation: 23 dB @ 2 GHz
- 0.5 micron GaAs PHEMT Process
- Lead-Free 4mm 16-lead PQFN Package
- 100% Matte Tin Plating over Copper
- Halogen-Free "Green" Mold Compound
- 260°C Reflow Compatible
- RoHS\* Compliant Version of MASWSS0118

### Description

M/A-COM's MASW-008566 is a GaAs PHEMT MMIC single pole four throw (SP4T) high power switch in a low cost 4 mm 16-lead PQFN package. The MASW-008566 is ideally suited for applications where high power, low control voltage, low insertion loss, high isolation, small size, and low cost are required.

Typical applications are for GSM and DCS handset systems that connect separate transmit and receive functions to a common antenna, as well as other handset and related applications. This part can be used in all systems operating up to 3.0 GHz requiring high power at low control voltage.

The MASW-008566 is fabricated using a 0.5 micron gate length GaAs PHEMT process. The process features full passivation for performance and reliability.

### Ordering Information<sup>1,2</sup>

Part Number	Package
MASW-008566-TR3000	3000 piece reel
MASW-008566-001SMB	Sample Board

1. Reference Application Note M513 for reel size information.
2. All sample boards include 5 loose parts.

### Functional Schematic

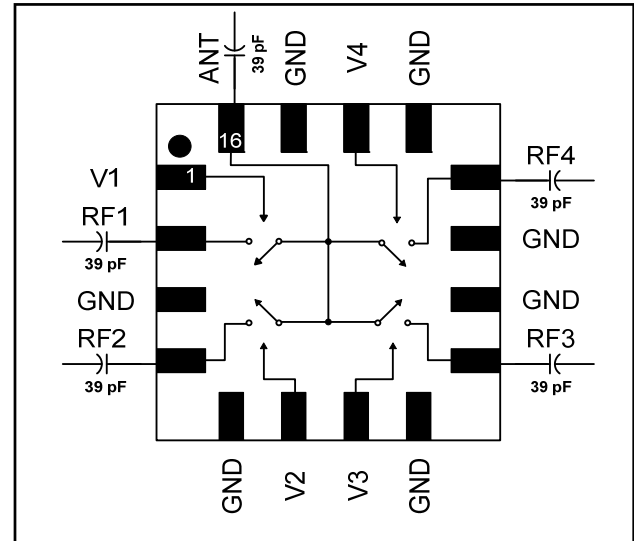

### Pin Configuration

Pin No.	Pin Name	Description
1	V1	Control 1
2	RF1	RF Port 1
3	GND	RF Ground
4	RF2	RF Port 2
5	GND	RF Ground
6	V2	Control 2
7	V3	Control 3
8	GND	RF Ground
9	RF3	RF Port 3
10	GND	RF Ground
11	GND	RF Ground
12	RF4	RF Port 4
13	GND	RF Ground
14	V4	Control 4
15	GND	RF Ground
16	ANT	Antenna Port
17	Paddle <sup>3</sup>	RF Ground

3. The exposed pad centered on the package bottom must be connected to RF and DC ground.

\* Restrictions on Hazardous Substances, European Union Directive 2002/95/EC.

## GaAs SP4T 2.5 V High Power Switch DC - 3.0 GHz

Rev. V1

### Electrical Specifications: $T_A = 25^\circ\text{C}$ , $Z_0 = 50 \Omega$ <sup>4</sup>

Parameter	Test Conditions	Units	Min.	Typ.	Max.
Insertion Loss <sup>5</sup>	DC – 1 GHz	dB	—	0.65	0.85
	1 – 2 GHz	dB	—	0.80	1.00
	2 - 3 GHz	dB	—	1.00	—
Isolation	DC – 1 GHz	dB	27	29.0	—
	1 – 2 GHz	dB	21	23.0	—
	2 - 3 GHz	dB	—	18.5	—
Return Loss	DC – 3 GHz	dB	—	20	—
IP3	Two Tone +26 dBm, 5 MHz Spacing, > 50 MHz $V_C = 0 \text{ V} / 2.5 \text{ V}$	dBm	—	57	—
IP2	Two Tone +26 dBm, 5 MHz Spacing, > 50 MHz $V_C = 0 \text{ V} / 2.5 \text{ V}$	dBm	—	81	—
P.1dB	$V_C = 0 \text{ V} / 2.5 \text{ V}$	dBm	—	38	—
2 <sup>nd</sup> Harmonic	1 GHz, $P_{IN} = +34 \text{ dBm}$ , $V_C = 0 \text{ V} / 2.5 \text{ V}$	dBc	—	-80	-71
3 <sup>rd</sup> Harmonic	1 GHz, $P_{IN} = +34 \text{ dBm}$ , $V_C = 0 \text{ V} / 2.5 \text{ V}$	dBc	—	-68	-65
Trise, Tfall	10% RF to 90% RF, 90% to 10% RF, $V_C = 0 \text{ V} / 2.5 \text{ V}$	$\mu\text{S}$	—	0.2	—
Ton, Toff	50% control to 90% RF, 50% control to 10% RF, $V_C = 0 \text{ V} / 2.5 \text{ V}$	$\mu\text{S}$	—	0.2	—
Transients		mV	—	35	—
Control Current	$V_C = 0 \text{ V} / 2.5 \text{ V}$ , 34 dBm	$\mu\text{A}$	—	10	50

4. External DC blocking capacitors are required on all RF ports.

5. Insertion Loss can be optimized by varying the DC blocking capacitor value, e.g. 1000 pF for 100 - 500 MHz, 39 pF for 0.5 - 3 GHz.

### Absolute Maximum Ratings<sup>6,7</sup>

Parameter	Absolute Maximum
Input Power (0.5 - 3.0 GHz, 2.5 V Control)	+38 dBm
Voltage	$\pm 8.5$ volts
Operating Temperature	$-40^\circ\text{C}$ to $+85^\circ\text{C}$
Storage Temperature	$-65^\circ\text{C}$ to $+150^\circ\text{C}$

6. Exceeding any one or combination of these limits may cause permanent damage to this device.

7. M/A-COM does not recommend sustained operation near these survivability limits.

### Truth Table<sup>8,9</sup>

V1	V2	V3	V4	ANT-RF1	ANT-RF2	ANT-RF3	ANT-RF4
1	0	0	0	On	Off	Off	Off
0	1	0	0	Off	On	Off	Off
0	0	1	0	Off	Off	On	Off
0	0	0	1	Off	Off	Off	On

8. Differential voltage, V (state 1) -V (state 2), must be 2.5 V minimum.

9. 0 = -5 V to +2.5 V, 1 = -2.5 V to +5 V

## Typical Performance Curves

**Insertion Loss vs. Temperature**

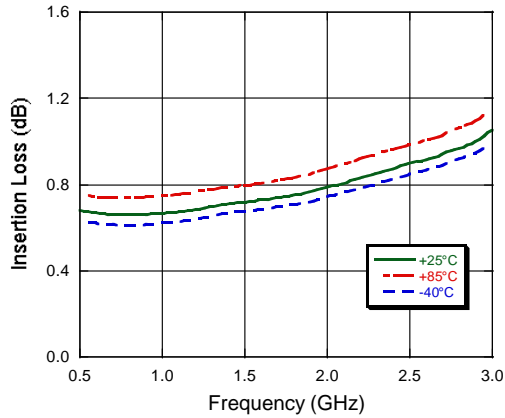

**Isolation vs. Temperature**

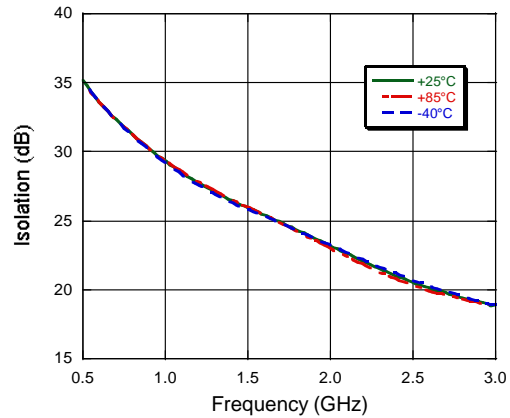

**1 GHz 2nd Harmonic Rejection**

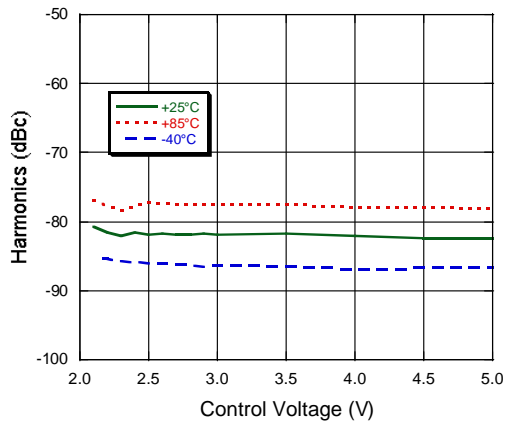

**1 GHz 3rd Harmonic Rejection**

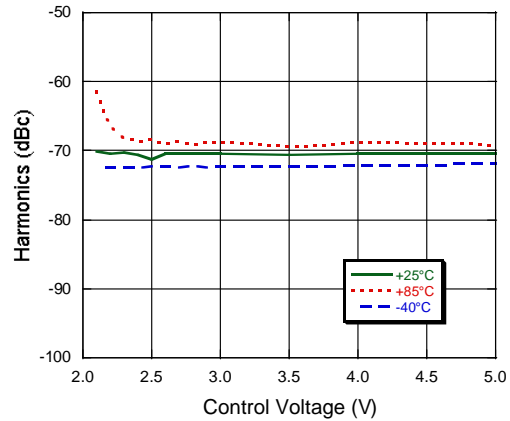

## Lead-Free 4 mm 16-Lead PQFN†

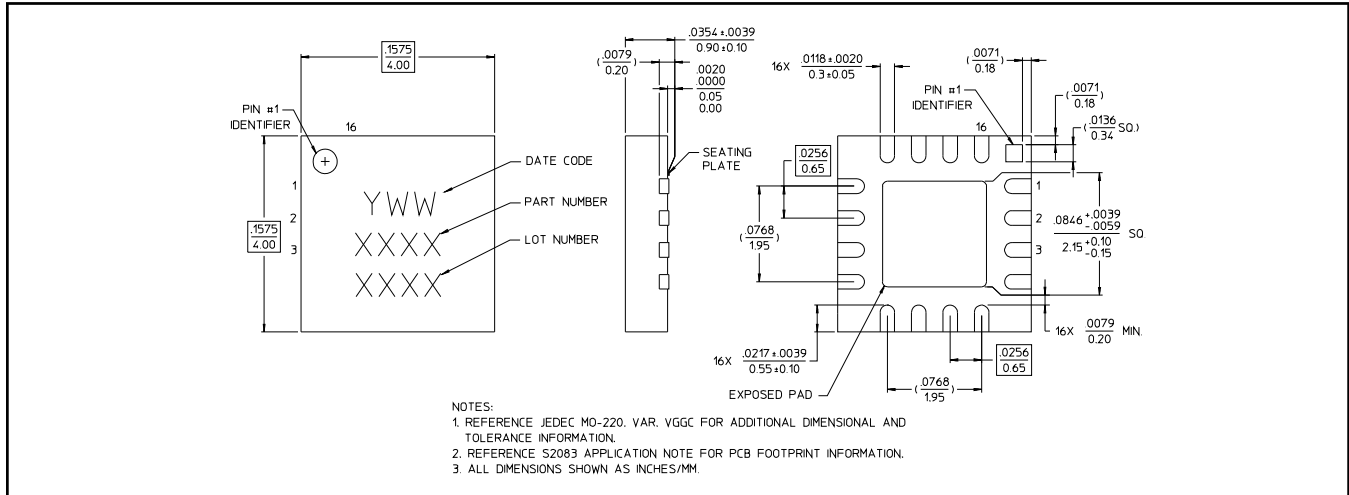

† Reference Application Note M538 for lead-free solder reflow recommendations.  
Meets JEDEC moisture sensitivity level 1 requirements.

## Handling Procedures

Please observe the following precautions to avoid damage:

## Static Sensitivity

Gallium Arsenide Integrated Circuits are sensitive to electrostatic discharge (ESD) and can be damaged by static electricity. Proper ESD control techniques should be used when handling these devices.



Компания «ЭлектроПласт» предлагает заключение долгосрочных отношений при поставках импортных электронных компонентов на взаимовыгодных условиях!

Наши преимущества:

- Оперативные поставки широкого спектра электронных компонентов отечественного и импортного производства напрямую от производителей и с крупнейших мировых складов;
- Поставка более 17-ти миллионов наименований электронных компонентов;
- Поставка сложных, дефицитных, либо снятых с производства позиций;
- Оперативные сроки поставки под заказ (от 5 рабочих дней);
- Экспресс доставка в любую точку России;
- Техническая поддержка проекта, помощь в подборе аналогов, поставка прототипов;
- Система менеджмента качества сертифицирована по Международному стандарту ISO 9001;
- Лицензия ФСБ на осуществление работ с использованием сведений, составляющих государственную тайну;
- Поставка специализированных компонентов (Xilinx, Altera, Analog Devices, Intersil, Interpoint, Microsemi, Aeroflex, Peregrine, Syfer, Eurofarad, Texas Instrument, Miteq, Cobham, E2V, MA-COM, Hittite, Mini-Circuits, General Dynamics и др.);

Помимо этого, одним из направлений компании «ЭлектроПласт» является направление «Источники питания». Мы предлагаем Вам помощь Конструкторского отдела:

- Подбор оптимального решения, техническое обоснование при выборе компонента;
- Подбор аналогов;
- Консультации по применению компонента;
- Поставка образцов и прототипов;
- Техническая поддержка проекта;
- Защита от снятия компонента с производства.



#### Как с нами связаться

**Телефон:** 8 (812) 309 58 32 (многоканальный)

**Факс:** 8 (812) 320-02-42

**Электронная почта:** [org@eplast1.ru](mailto:org@eplast1.ru)

**Адрес:** 198099, г. Санкт-Петербург, ул. Калинина, дом 2, корпус 4, литера А.