

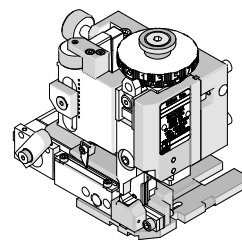

**Mini-Mac  
Applicator**

**Application Tooling  
Specification Sheet**



**Order No. 63893-4300**

**FEATURES**

- Directly adapts to most automatic wire processing machines
- Applicator designed to industry standard mounting and shut height 135.80mm (5.346")
- Quick set-up time; plus the crimp height, track and feed adjustments can be set without removing the applicator from the press
- Fine adjustment allows users to achieve target with little effort by adjusting in increments of .015mm (.0006") for barrel crimp height and .063mm (.0025") for insulation height. See notes on Page 2.
- Independent adjustment rings allow users to quickly adjust the barrel or insulation crimp height without affecting each other.

**SCOPE**

Products: Board-In Crimp Terminal Male, 18-24 AWG.

Terminal Series No.	Terminal Order No.		Wire Size		Insulation Diameter Maximum		Strip Length	
			AWG	mm <sup>2</sup>	mm	In.	mm	In.
4706	02-07-2101	50-29-1688	18-24	0.80-0.20	3.05	.120	5.97-6.35	.235-.250

**DEFINITION OF TERMS**

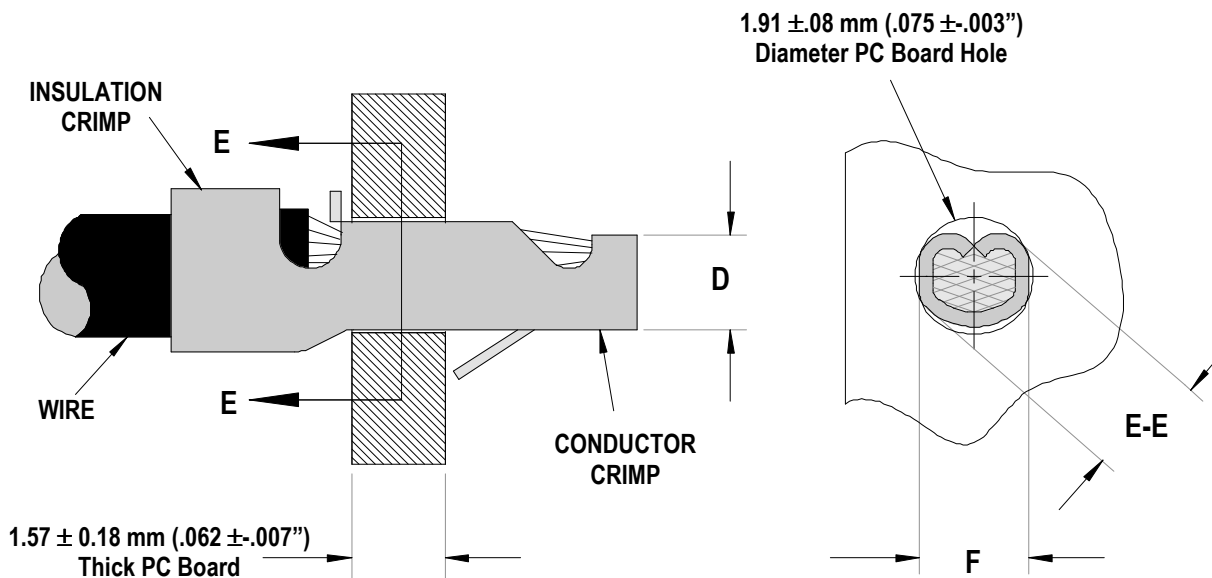

Figure 1

Section E-E

## CRIMP SPECIFICATIONS

After crimping, the conductor profiles should measure the following (See Figure 1).

Terminal Series No.	Wire Size		Dimensions (Figure 1)						Pull Force Minimum (4)	
			D (Ref.)(Conductor)		E-E (Barrel)		F (Ref.)		N	Lb.
	AWG	mm <sup>2</sup>	mm	In.	mm	In.	mm	In.		
4706	18	0.80	1.12	.044	1.72-1.78	.068-.070	.055	1.40	13.34	3.0
	20	0.50	1.12	.044	1.72-1.78	.068-.070	.055	1.40	13.34	3.0
	(5) 22	0.35	0.97	.030	1.72-1.78	.068-.070	.055	1.40	13.34	3.0
	(5) 24	0.20	0.97	.030	1.72-1.78	.068-.070	.055	1.40	13.34	3.0

**For the numbers in parentheses follow the number item below.**

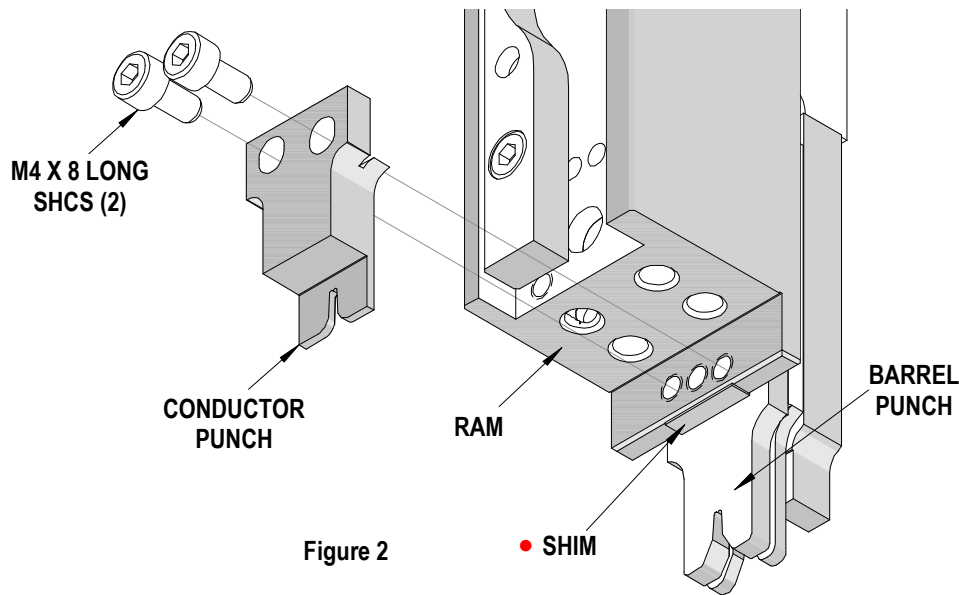

Figure 2

- Shim location for Conductor Punch. Shim size should be .25 by 3.2 by 12.7mm (.010 by 1/8 by 1/2")

### Notes:

1. To prevent conductor tooling damage with this applicator make sure the shut height of your crimp press is set to 135.80mm (5.346") before installing the applicator. Also hand cycle the first crimp to verify tooling alignment.
2. The reference conductor crimp heights listed in the table above are suggested to achieve the minimum pull force.
3. **Because the soldering operation between the wire and terminal is the electrical connection and not the conductor crimp**, the conductor crimp height can deviate from the suggested values listed in the table above due to wire type or other variables.
4. The minimum pull force for this board-in terminal does include both the insulation and conductor crimps.
5. To achieve the conductor crimp height (D dimension in Figure 1) for 22 and 24ga wire, a 0.25mm (.010") thick shim is required if your crimp press is not equipped with adjustable shut height. This shim is not supplied with the applicator. The shim should be located between the Ram and the Conductor Punch. See Figure 2.

**PARTS LIST**

<b>Mini-Mac Applicator 63893-4300</b>				
<b>Item</b>	<b>Order No</b>	<b>Engineering No.</b>	<b>Description</b>	<b>Quantity</b>
<b>Perishable Tooling</b>				
	63893-4370	63893-4370	Tool Kit (All "Y" Items)	REF
1	11-18-4220	60714-16	Conductor Punch	1 Y
2	63801-5977	63801-5977	Insulation Punch	1 Y
3	11-18-4787	60714B104	Conductor Anvil	1 Y
4	11-18-4212	60714-8	Insulation Anvil	1 Y
5	63801-5976	63801-5976	Barrel Form Punch	1 Y
6	11-18-4788	60714B109	Barrel Form Anvil	1 Y
7	63893-4105	63893-4105	Front Cut-off Plunger	1 Y
8	11-18-4176	60718-15	Front Plunger Guide Block	1 Y
<b>Other Components</b>				
9	11-18-4083	60707-8	Feed Guide	1
10	11-18-4167	60718-6	Plunger Striker	1
11	11-18-4206	60714-2	Cover Plate	1
12	11-18-4207	60714-3	Wire Stop	1
13	11-18-4208	60714-4	Rear Plunger Retainer	1
14	11-18-4789	60714B113	Terminal Guide	1
15	11-18-4849	60800A124	Wire Hold Down Spring	1
16	11-18-4944	60710-21	Cut-off Plunger Spring	2
17	63803-5135	63803-5135	Conductor Bushing	1
18	63803-5202	63803-5202	Insulation Bushing	1
<b>Frame</b>				
19	63801-3201	63801-3201	Top	1
20	63801-3282	63801-3282	Base	1
21	63801-6550	63801-6550	Track	1
<b>Hardware</b>				
22	N/A	N/A	M3 by 5 Long SHCS	2**
23	N/A	N/A	M3 by 8 Long SHCS	2**
24	N/A	N/A	M4 by 8 Long SHCS	2**
25	N/A	N/A	M4 by 10 Long SHCS	2**
26	N/A	N/A	M8 by 20 Long BHCS	1**
27	N/A	N/A	#8-32 by 3/8" Long BHCS	4**
28	N/A	N/A	#10-32 by 3/4" Long SHCS	1**
** Available from an industrial supply company such as MSC (1-800-645-7270).				

### Assembly Drawing

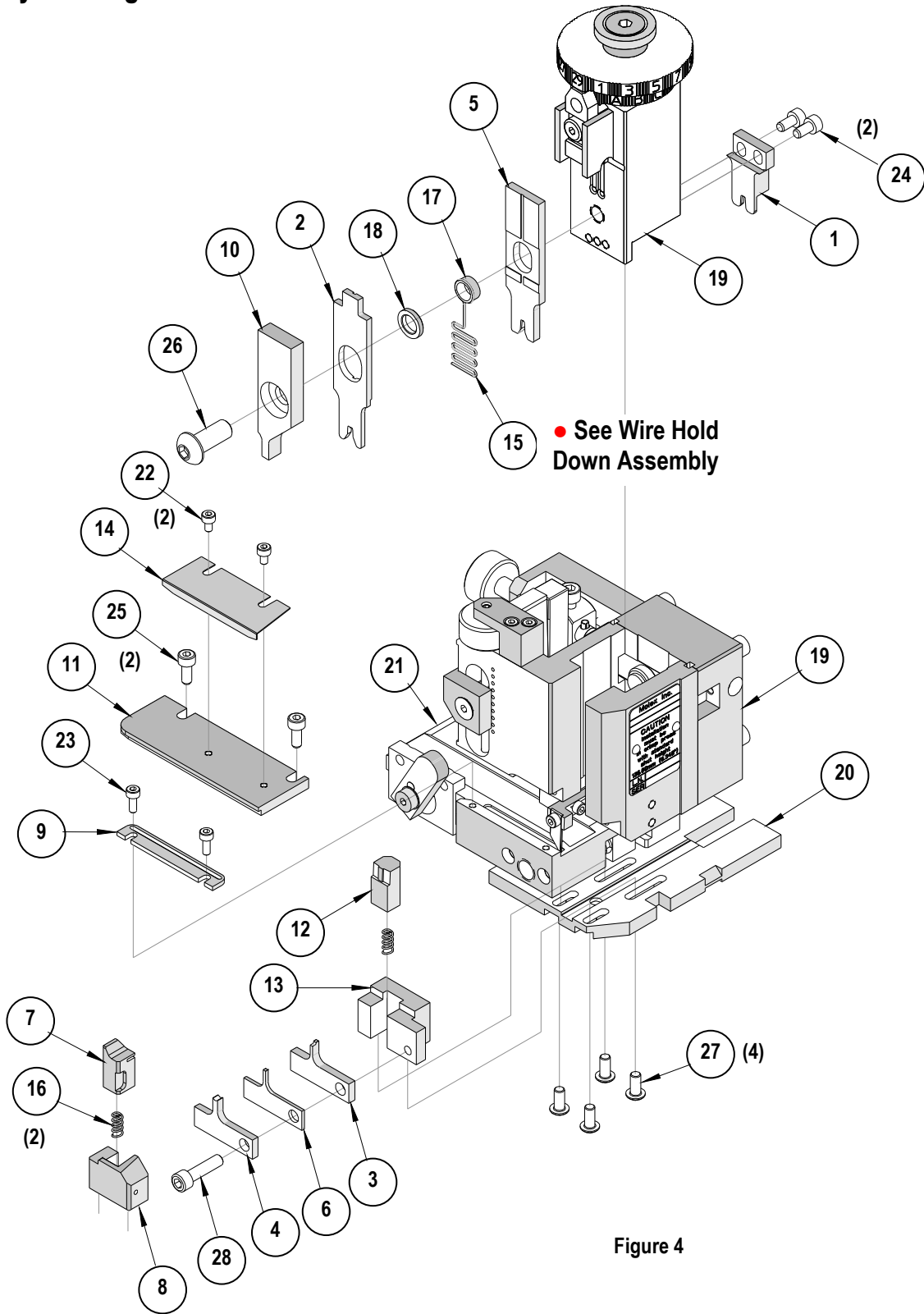

Figure 4

● **Wire Hold Down Assembly**

The wire hold down spring is assembled onto the outside diameter of the conductor bushing.

The location of the spring on the outside diameter of the bushing should be flush with the bushings surface edge as shown. There is a clearance groove provided on the punches for the spring to fit between. See Figure 3.

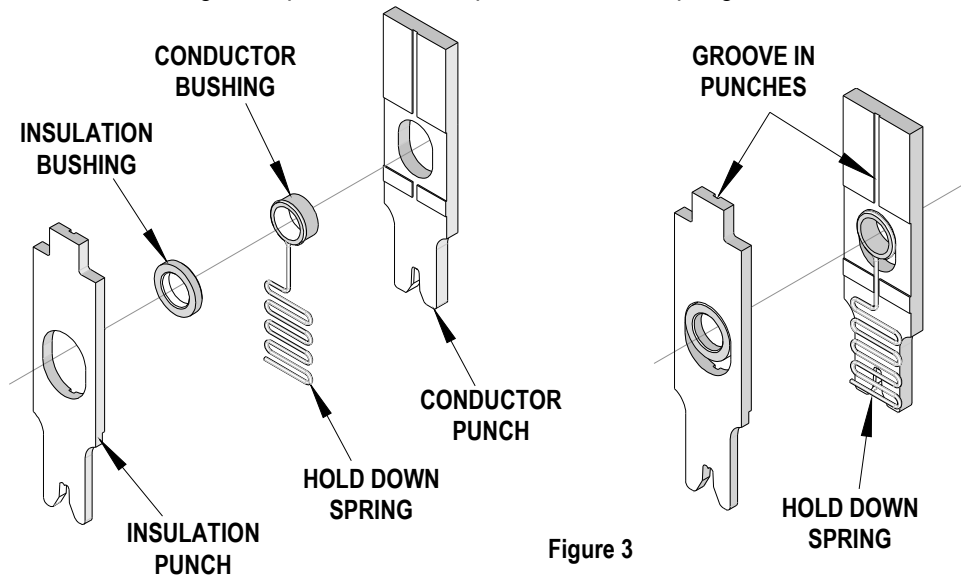

Figure 3

**NOTES**

1. Molex recommends an extra perishable tooling kit be maintained at your facility.
2. Verify tooling alignment by manually cycling the press and applicator before crimping under power. Check that all screws are tight.
3. Slugs, terminals, dirt, and oil should be kept clear of work area.
4. Wear safety glasses at all times.
5. For recommended maintenance refer to the Mini-Mac Manual.

**CAUTION:** This applicator should only be used in a press with a shut height of 135.80 mm (5.346"). Tooling damage could result at a lower setting

**CAUTION:** To prevent injury, never operate this applicator without the guards supplied with the press or wire-processing machine in place. Reference the press or wire processing manufacturer's instruction manual.

**CAUTION:** Molex crimp specifications are valid only when used with Molex terminals, applicators and tooling.

**Contact Information**

For more information on Molex application tooling please contact Molex at 1-800-786-6539.

Visit our Web site at <http://www.molex.com>



Компания «ЭлектроПласт» предлагает заключение долгосрочных отношений при поставках импортных электронных компонентов на взаимовыгодных условиях!

Наши преимущества:

- Оперативные поставки широкого спектра электронных компонентов отечественного и импортного производства напрямую от производителей и с крупнейших мировых складов;
- Поставка более 17-ти миллионов наименований электронных компонентов;
- Поставка сложных, дефицитных, либо снятых с производства позиций;
- Оперативные сроки поставки под заказ (от 5 рабочих дней);
- Экспресс доставка в любую точку России;
- Техническая поддержка проекта, помощь в подборе аналогов, поставка прототипов;
- Система менеджмента качества сертифицирована по Международному стандарту ISO 9001;
- Лицензия ФСБ на осуществление работ с использованием сведений, составляющих государственную тайну;
- Поставка специализированных компонентов (Xilinx, Altera, Analog Devices, Intersil, Interpoint, Microsemi, Aeroflex, Peregrine, Syfer, Eurofarad, Texas Instrument, Miteq, Cobham, E2V, MA-COM, Hittite, Mini-Circuits, General Dynamics и др.);

Помимо этого, одним из направлений компании «ЭлектроПласт» является направление «Источники питания». Мы предлагаем Вам помощь Конструкторского отдела:

- Подбор оптимального решения, техническое обоснование при выборе компонента;
- Подбор аналогов;
- Консультации по применению компонента;
- Поставка образцов и прототипов;
- Техническая поддержка проекта;
- Защита от снятия компонента с производства.



#### Как с нами связаться

**Телефон:** 8 (812) 309 58 32 (многоканальный)

**Факс:** 8 (812) 320-02-42

**Электронная почта:** [org@eplast1.ru](mailto:org@eplast1.ru)

**Адрес:** 198099, г. Санкт-Петербург, ул. Калинина, дом 2, корпус 4, литера А.