

FEATURES

- 3.3V and 5V power supply options
- 265ps propagation delay
- 5ps skew between outputs
- High bandwidth output transitions
- Internal 75K Ω input pull-down resistors
- Replaces SY10/100EL11
- Improved output waveform characteristics
- Available in 8-pin SOIC package



Precision Edge®

DESCRIPTION

The SY10/100EL11V are 1:2 differential fanout gates. These devices are functionally similar to the E111A/L devices, with higher performance capabilities. Having within-device skews and output transition times significantly improved over the E111A/L, the EL11V is ideally suited for those applications which require the ultimate in AC performance.

The differential inputs of the EL11V employ clamping circuitry to maintain stability under open input conditions. If the inputs are left open (pulled to VEE), the Q outputs will go LOW.

PIN NAMES

Pin	Function
D	Data Inputs
Q0, Q1	Data Outputs

PACKAGE/ORDERING INFORMATION

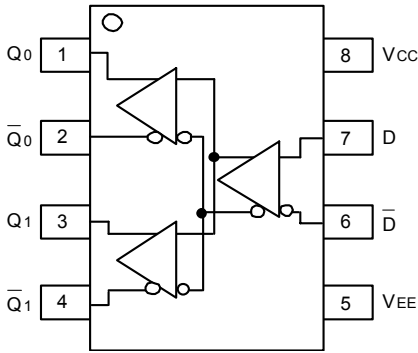

8-Pin SOIC (Z8-1)

Ordering Information⁽¹⁾

Part Number	Package Type	Operating Range	Package Marking	Lead Finish
SY10EL11VZC	Z8-1	Commercial	HEL11V	Sn-Pb
SY10EL11VZCTR ⁽²⁾	Z8-1	Commercial	HEL11V	Sn-Pb
SY100EL11VZC	Z8-1	Commercial	XEL11V	Sn-Pb
SY100EL11VZCTR ⁽²⁾	Z8-1	Commercial	XEL11V	Sn-Pb
SY10EL11VZI	Z8-1	Industrial	HEL11V	Sn-Pb
SY10EL11VZITR ⁽²⁾	Z8-1	Industrial	HEL11V	Sn-Pb
SY100EL11VZI	Z8-1	Industrial	XEL11V	Sn-Pb
SY100EL11VZITR ⁽²⁾	Z8-1	Industrial	XEL11V	Sn-Pb
SY10EL11VZG ⁽³⁾	Z8-1	Industrial	HEL11V with Pb-Free bar-line indicator	Pb-Free NiPdAu
SY10EL11VZGTR ^(2, 3)	Z8-1	Industrial	HEL11V with Pb-Free bar-line indicator	Pb-Free NiPdAu
SY100EL11VZG ⁽³⁾	Z8-1	Industrial	XEL11V with Pb-Free bar-line indicator	Pb-Free NiPdAu
SY100EL11VZGTR ^(2, 3)	Z8-1	Industrial	XEL11V with Pb-Free bar-line indicator	Pb-Free NiPdAu

Notes:

1. Contact factory for die availability. Dice are guaranteed at T_A = 25°C, DC Electricals only.
2. Tape and Reel.
3. Pb-Free package is recommended for new designs.

ABSOLUTE MAXIMUM RATINGS⁽¹⁾

Symbol	Rating	Value	Unit
V _{CC}	Power Supply Voltage (V _{EE} = 0)	+6.0 to 0	V
V _{EE}	Power Supply Voltage (V _{CC} = 0)	-6.0 to 0	V
V _{IN}	Input Voltage (V _{CC} = 0V, V _{IN} not more negative than V _{EE}) Input Voltage (V _{EE} = 0V, V _{IN} not more positive than V _{CC})	-6.0 to 0	V
		+6.0 to 0	V
I _{OUT}	Output Current	-Continuous	50
		-Surge	100
T _{LEAD}	Lead Temperature Range (soldering, 20sec.)	+260	°C
T _A	Operating Temperature Range	-40 to +85	°C
T _{store}	Storage Temperature Range	-65 to +150	°C
θ _{JA}	Thermal Resistance (Junction-to-Ambient)	-Still Air	160
		-500lfpm	109
θ _{JC}	Thermal Resistance (Junction-to-Case)	39	°C/W
ESD	Mil Std. 883 Human Body Model, All Pins	>1.5k	V

Note 1. Permanent device damage may occur if absolute maximum ratings are exceeded. This is a stress rating only and functional operation is not implied at conditions other than those detailed in the operational sections of this data sheet. Exposure to absolute maximum rating conditions for extended periods may affect device reliability.

10K SERIES DC ELECTRICAL CHARACTERISTICS⁽¹⁾

V_{CC} = 3.3V ±10%; V_{EE} = 0V

Symbol	Parameter	T _A = -40°C		T _A = 0°C		T _A = +25°C		T _A = +85°C		Unit
		Min.	Max.	Min.	Max.	Min.	Max.	Min.	Max.	
V _{OH}	Output HIGH Voltage	-1080	-890	-1020	-840	-980	-810	-910	-720	mV
V _{OL}	Output LOW Voltage	-1950	-1650	-1950	-1630	-1950	-1630	-1950	-1595	mV
V _{IH}	Input HIGH Voltage	-1230	-890	-1170	-840	-1130	-810	-1060	-720	mV
V _{IL}	Input LOW Voltage	-1950	-1500	-1950	-1480	-1950	-1480	-1950	-1445	mV
I _{IH}	Input HIGH Current	—	150	—	150	—	150	—	150	µA
I _{IL}	Input LOW Current	0.5	—	0.5	—	0.5	—	0.3	—	µA

100K SERIES DC ELECTRICAL CHARACTERISTICS⁽²⁾

V_{CC} = 3.3V ±10%; V_{EE} = 0V

Symbol	Parameter	T _A = -40°C			T _A = 0°C to +85°C			Unit	Conditions
		Min.	Typ.	Max.	Min.	Typ.	Max.		
V _{OH}	Output HIGH Voltage	-1085	-1005	-880	-1025	-955	-880	mV	V _{IN} = V _{IH} (Max) or V _{IL} (Min)
V _{OL}	Output LOW Voltage	-1830	-1695	-1555	-1810	-1705	-1620	mV	
V _{IH}	Input HIGH Voltage ⁽³⁾	-1165	—	-880	-1165	—	-880	mV	
V _{IL}	Input LOW Voltage ⁽⁴⁾	-1810	—	-1475	-1810	—	-1475	mV	
I _{IH}	Input HIGH Current	—	—	150	—	—	150	µA	
I _{IL}	Input LOW Current	0.5	—	—	0.5	—	—	µA	V _{IN} = V _{IL} (Min)

10K SERIES DC ELECTRICAL CHARACTERISTICS⁽¹⁾VCC = 5.0V \pm 10%; VEE = 0V

Symbol	Parameter	TA = -40°C		TA = 0°C		TA = +25°C		TA = +85°C		Unit
		Min.	Max.	Min.	Max.	Min.	Max.	Min.	Max.	
VOH	Output HIGH Voltage	-1080	-890	-1020	-840	-980	-810	-910	-720	mV
VOL	Output LOW Voltage	-1950	-1650	-1950	-1630	-1950	-1630	-1950	-1595	mV
VIH	Input HIGH Voltage	-1230	-890	-1170	-840	-1130	-810	-1060	-720	mV
VIL	Input LOW Voltage	-1950	-1500	-1950	-1480	-1950	-1480	-1950	-1445	mV
I _{IH}	Input HIGH Current	—	150	—	150	—	150	—	150	μA
I _{IL}	Input LOW Current	0.5	—	0.5	—	0.5	—	0.3	—	μA

100K SERIES DC ELECTRICAL CHARACTERISTICS⁽²⁾VCC = 5.0V \pm 10%; VEE = 0V

Symbol	Parameter	TA = -40°C			TA = 0°C to +85°C			Unit	Conditions
		Min.	Typ.	Max.	Min.	Typ.	Max.		
VOH	Output HIGH Voltage	-1085	-1005	-880	-1025	-955	-880	mV	VIN = VIH(Max) or VIL(Min)
VOL	Output LOW Voltage	-1830	-1695	-1555	-1810	-1705	-1620		
VIH	Input HIGH Voltage ⁽³⁾	-1165	—	-880	-1165	—	-880	mV	
VIL	Input LOW Voltage ⁽⁴⁾	-1810	—	-1475	-1810	—	-1475	mV	
I _{IH}	Input HIGH Current	—	—	150	—	—	150	μA	
I _{IL}	Input LOW Current	0.5	—	—	0.5	—	—	μA	VIN = VIL(Min)

10K SERIES DC ELECTRICAL CHARACTERISTICS⁽¹⁾

VCC = 0V; VEE = -3.3V ±10%

Symbol	Parameter	TA = -40°C		TA = 0°C		TA = +25°C		TA = +85°C		Unit
		Min.	Max.	Min.	Max.	Min.	Max.	Min.	Max.	
VOH	Output HIGH Voltage	-1080	-890	-1020	-840	-980	-810	-910	-720	mV
VOL	Output LOW Voltage	-1950	-1650	-1950	-1630	-1950	-1630	-1950	-1595	mV
VIH	Input HIGH Voltage	-1230	-890	-1170	-840	-1130	-810	-1060	-720	mV
VIL	Input LOW Voltage	-1950	-1500	-1950	-1480	-1950	-1480	-1950	-1445	mV
IiH	Input HIGH Current	—	150	—	150	—	150	—	150	µA
IiL	Input LOW Current	0.5	—	0.5	—	0.5	—	0.3	—	µA

100K SERIES DC ELECTRICAL CHARACTERISTICS⁽²⁾

VCC = 0V; VEE = -3.3V ±10%

Symbol	Parameter	TA = -40°C			TA = 0°C to +85°C			Unit	Conditions
		Min.	Typ.	Max.	Min.	Typ.	Max.		
VOH	Output HIGH Voltage	-1085	-1005	-880	-1025	-955	-880	mV	VIN = VIH(Max) or VIL(Min)
VOL	Output LOW Voltage	-1830	-1695	-1555	-1810	-1705	-1620	mV	
VIH	Input HIGH Voltage ⁽³⁾	-1165	—	-880	-1165	—	-880	mV	
VIL	Input LOW Voltage ⁽⁴⁾	-1810	—	-1475	-1810	—	-1475	mV	
IiH	Input HIGH Current	—	—	150	—	—	150	µA	
IiL	Input LOW Current	0.5	—	—	0.5	—	—	µA	VIN = VIL(Min)

10K SERIES DC ELECTRICAL CHARACTERISTICS⁽¹⁾

VCC = 0V; VEE = -5.0V ±10%

Symbol	Parameter	TA = -40°C		TA = 0°C		TA = +25°C		TA = +85°C		Unit
		Min.	Max.	Min.	Max.	Min.	Max.	Min.	Max.	
VOH	Output HIGH Voltage	-1080	-890	-1020	-840	-980	-810	-910	-720	mV
VOL	Output LOW Voltage	-1950	-1650	-1950	-1630	-1950	-1630	-1950	-1595	mV
VIH	Input HIGH Voltage	-1230	-890	-1170	-840	-1130	-810	-1060	-720	mV
VIL	Input LOW Voltage	-1950	-1500	-1950	-1480	-1950	-1480	-1950	-1445	mV
IiH	Input HIGH Current	—	150	—	150	—	150	—	150	µA
IiL	Input LOW Current	0.5	—	0.5	—	0.5	—	0.3	—	µA

100K SERIES DC ELECTRICAL CHARACTERISTICS⁽²⁾

VCC = 0V; VEE = -5.0V ±10%

Symbol	Parameter	TA = -40°C			TA = 0°C to +85°C			Unit	Conditions
		Min.	Typ.	Max.	Min.	Typ.	Max.		
VOH	Output HIGH Voltage	-1085	-1005	-880	-1025	-955	-880	mV	VIN = VIH(Max) or VIL(Min)
VOL	Output LOW Voltage	-1830	-1695	-1555	-1810	-1705	-1620	mV	
VIH	Input HIGH Voltage ⁽³⁾	-1165	—	-880	-1165	—	-880	mV	
VIL	Input LOW Voltage ⁽⁴⁾	-1810	—	-1475	-1810	—	-1475	mV	
IiH	Input HIGH Current	—	—	150	—	—	150	µA	
IiL	Input LOW Current	0.5	—	—	0.5	—	—	µA	VIN = VIL(Min)

Notes:

- 10EL circuits are designed to meet the DC specifications shown in the table after thermal equilibrium has been established. The circuit is in a test socket or mounted on a printed circuit board and transverse airflow greater than 500lfpm is maintained. Outputs are terminated through a 50Ω resistor to -2.0V except where otherwise specified on the individual data sheets.
- This table replaces the three tables traditionally seen in ECL 100K data books. The same DC parameter values at VEE = -4.5V now apply across the full VEE range of -4.2V to -5.5V. Outputs are terminated through a 50Ω resistor to -2.0V except where otherwise specified on the individual data sheets. 100K circuits are designed to meet the DC specifications shown in the table where transverse airflow greater than 500lfpm is maintained.
- Guaranteed HIGH Signal for all Inputs.
- Guaranteed LOW Signal for all Inputs.

AC ELECTRICAL CHARACTERISTICS⁽¹⁾

VEE = VEE (Min.) to VEE (Max.); VCC = GND

Symbol	Parameter	TA = -40°C			TA = 0°C			TA = +25°C			TA = +85°C			Unit
		Min.	Typ.	Max.	Min.	Typ.	Max.	Min.	Typ.	Max.	Min.	Typ.	Max.	
t _{PLH} t _{PHL}	Propagation Delay to Output D	135	260	385	185	260	335	190	265	340	215	290	365	ps
t _{skew}	Within-Device Skew ⁽²⁾ Duty Cycle Skew ⁽³⁾	—	5	—	—	5	20	—	5	20	—	5	20	ps
t _{JITTER}	Random Clock Jitter (RMS)	—	—	—	—	—	—	—	0.6	—	—	—	—	ps
V _{PP}	Minimum Input Swing ⁽⁴⁾	150	—	—	150	—	—	150	—	—	150	—	—	mV
V _{CMR}	Common Mode Range ⁽⁵⁾	-1.3	—	-0.4	-1.4	—	-0.4	-1.4	—	-0.4	-1.4	—	-0.4	V
t _r t _f	Output Rise/Fall Times Q (20% to 80%)	100	225	350	100	225	350	100	225	350	100	225	350	ps

Notes:

1. Parametric values specified at: 10/100EL11V Series: -3.0V to -5.5V.
2. Within-device skew defined as identical transitions on similar paths through a device.
3. Duty cycle skew is the difference between a t_{PLH} and t_{PHL} propagation delay through a device.
4. Minimum input swing for which AC parameters are guaranteed. The device has a DC gain of 40.
5. The CMR range is referenced to the most positive side of the differential input signal. Normal operation is obtained if the HIGH level falls within the specified range and the peak-to-peak voltage lies between V_{PP} min. and 1V. The lower end of the CMR range varies 1:1 with VEE. The numbers in the spec table assume a nominal VEE = -3.3V. Note for PECL operation, the V_{CMR} (min) will be fixed at 3.3V - |V_{CMR} (min)|.

8-PIN SOIC .150" WIDE (Z8-1)

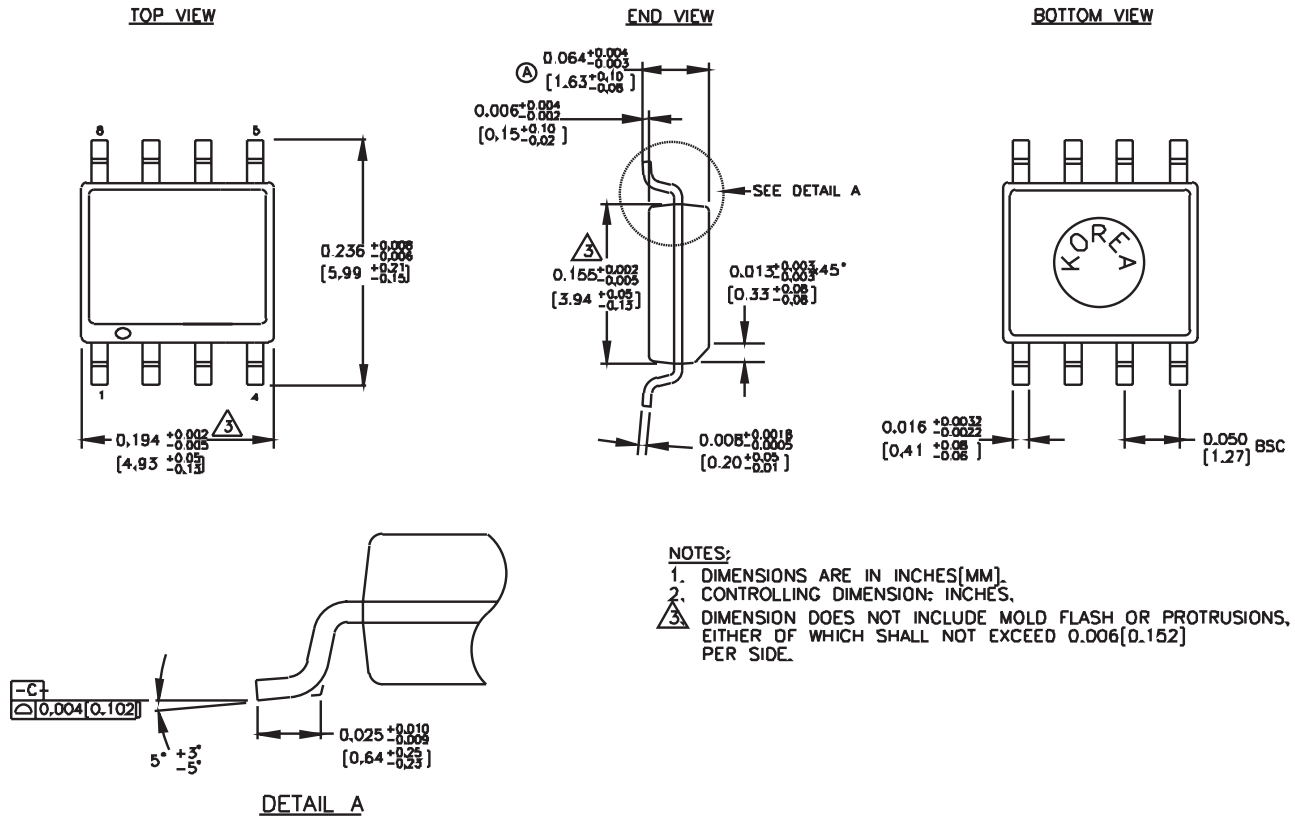

Package Notes:

Note 1. Package meets Level 1 moisture sensitivity.

MICREL, INC. 2180 FORTUNE DRIVE SAN JOSE, CA 95131 USA

TEL + 1 (408) 944-0800 FAX + 1 (408) 474-1000 WEB <http://www.micrel.com>

The information furnished by Micrel in this datasheet is believed to be accurate and reliable. However, no responsibility is assumed by Micrel for its use. Micrel reserves the right to change circuitry and specifications at any time without notification to the customer.

Micrel Products are not designed or authorized for use as components in life support appliances, devices or systems where malfunction of a product can reasonably be expected to result in personal injury. Life support devices or systems are devices or systems that (a) are intended for surgical implant into the body or (b) support or sustain life, and whose failure to perform can be reasonably expected to result in a significant injury to the user. A Purchaser's use or sale of Micrel Products for use in life support appliances, devices or systems is at Purchaser's own risk and Purchaser agrees to fully indemnify Micrel for any damages resulting from such use or sale.

© 2003 Micrel, Incorporated.



Компания «ЭлектроПласт» предлагает заключение долгосрочных отношений при поставках импортных электронных компонентов на взаимовыгодных условиях!

Наши преимущества:

- Оперативные поставки широкого спектра электронных компонентов отечественного и импортного производства напрямую от производителей и с крупнейших мировых складов;
- Поставка более 17-ти миллионов наименований электронных компонентов;
- Поставка сложных, дефицитных, либо снятых с производства позиций;
- Оперативные сроки поставки под заказ (от 5 рабочих дней);
- Экспресс доставка в любую точку России;
- Техническая поддержка проекта, помощь в подборе аналогов, поставка прототипов;
- Система менеджмента качества сертифицирована по Международному стандарту ISO 9001;
- Лицензия ФСБ на осуществление работ с использованием сведений, составляющих государственную тайну;
- Поставка специализированных компонентов (Xilinx, Altera, Analog Devices, Intersil, Interpoint, Microsemi, Aeroflex, Peregrine, Syfer, Eurofarad, Texas Instrument, Miteq, Cobham, E2V, MA-COM, Hittite, Mini-Circuits, General Dynamics и др.);

Помимо этого, одним из направлений компании «ЭлектроПласт» является направление «Источники питания». Мы предлагаем Вам помощь Конструкторского отдела:

- Подбор оптимального решения, техническое обоснование при выборе компонента;
- Подбор аналогов;
- Консультации по применению компонента;
- Поставка образцов и прототипов;
- Техническая поддержка проекта;
- Защита от снятия компонента с производства.



Как с нами связаться

Телефон: 8 (812) 309 58 32 (многоканальный)

Факс: 8 (812) 320-02-42

Электронная почта: org@eplast1.ru

Адрес: 198099, г. Санкт-Петербург, ул. Калинина, дом 2, корпус 4, литера А.