

Evaluating the **ADM3063E** 3.0 V to 5.5 V, ± 12 kV IEC ESD Protected, 500 kbps, RS-485 Transceiver

FEATURES

- Easy evaluation of **ADM3063E** 500 kbps, RS-485 transceiver
- Board layout for standard, full-duplex, RS-485 footprint
- 14-lead SOIC, **ADM3063EBRZ**
- Power/ground connections through screw terminal block
- 3.0 V to 5.5 V operating voltage range on V_{CC}
- IEC61000-4-2 ESD protection on the RS-485 A, B, Y and Z bus pins
- ± 12 kV contact discharge and ± 12 kV air discharge
- Screw terminal blocks for logic input/output and RS-485 signals
- Jumper-selectable enable/disable for RE and DE
- Test points for measuring all signals
- Resistors and footprints for termination and biasing networks

EVALUATION KIT CONTENTS

EVAL-ADM3063EEBZ evaluation board

ADDITIONAL EQUIPMENT NEEDED

- Oscilloscope
- Signal generator
- 3 V to 5 V supply

GENERAL DESCRIPTION

The EVAL-ADM3063EEBZ allows quick and easy evaluation of the **ADM3063E** 500 kbps, RS-485 transceiver with standard, 14-lead NSOIC footprint. The evaluation board allows the input and output functions to be exercised without external components. Screw terminal blocks provide convenient connections for power and ground, digital input and output, and RS-485 signals. The evaluation board can be powered by a standard configurable bench power supply within the 3.0 V to 5.5 V range.

The EVAL-ADM3063EEBZ evaluation board has a footprint for the **ADM3063EBRZ** full duplex, RS-485 transceiver in a 14-lead SOIC package.

For full details, see the **ADM3063E** data sheet, which must be used in conjunction with this user guide when using the EVAL-ADM3063EEBZ evaluation board.

EVALUATION BOARD PHOTOGRAPH

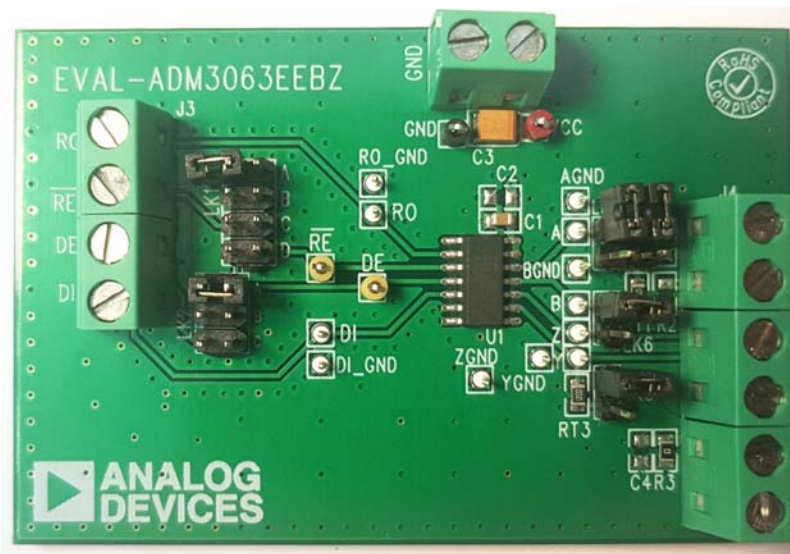

Figure 1.

TABLE OF CONTENTS

Features	1	Input and Output Connections	3
Evaluation Kit Contents.....	1	Other Board Components.....	3
Additional Equipment Needed	1	Full-Duplex RS-485 Transceivers Loopback Test	4
General Description	1	IEC 61000-4-2 Electrostatic Discharge (ESD) Protection to ±12 kV (Contact) and ±12 kV (Air)	4
Evaluation Board Photograph.....	1	Evaluation Board Schematics and Artwork	5
Revision History	2	Ordering Information.....	8
Evaluation Board Hardware.....	3	Bill of Materials.....	8
Setting Up the Evaluation Board.....	3		

REVISION HISTORY

4/2019—Revision 0: Initial Version

EVALUATION BOARD HARDWARE

SETTING UP THE EVALUATION BOARD

The EVAL-ADM3063EEBZ evaluation board is powered by connecting a 3.0 V or 5.5 V power supply to the J1 screw terminals for V_{CC} and GND at the top of the evaluation board. A 10 μF decoupling capacitor, C3, is fitted at the connector between V_{CC} and GND. The V_{CC} pin of the RS-485 transceiver is fitted with a 100 nF decoupling capacitor, C1, with a second footprint for an optional additional capacitor, C2.

Corresponding labeled test points allow monitoring of the power supply to the evaluation board and the probe reference to ground.

INPUT AND OUTPUT CONNECTIONS

Digital input and output signals are connected via the J3 screw terminal block, allowing wire connections from the evaluation board to a signal generator. The EVAL-ADM3063EEBZ includes connections for data input (DI), receiver output (RO), receiver enable (\overline{RE}), and driver enable (DE). Jumper connections on LK1 and LK2 can connect the DE and \overline{RE} digital inputs to the J3 terminal block, to V_{CC} or to GND (see Table 1).

Connections to an RS-485 bus are made via a screw terminal block, J4. For the EVAL-ADM3063EEBZ board, there are four bus input/output signals: A and B, for noninverting and inverting input signals, respectively, and Y and Z for noninverting and inverting output signals, respectively. The bus cable can also include a common ground connection or shield, and can be connected to the J4 screw terminal block of the evaluation boards. Test points are available on the evaluation board and are appropriately labeled for all digital and bus input/output signals.

OTHER BOARD COMPONENTS

The EVAL-ADM3063EEBZ evaluation board includes footprints for termination resistors, RT1 and RT3, as well as pull-up and pull-down resistors, R1 and R2, for the receiver inputs. Termination resistors of 120 Ω are fitted to the evaluation board; these resistors can be removed or replaced with a different value resistor as needed. Inserting jumper LK3 adds 120 Ω termination to the receiver inputs. Inserting jumper LK5 adds 120 Ω termination to the transmitter output.

Biasing Resistors for Bus Idle Fail-Safe

Although the ADM3063E has a built-in receiver fail-safe for the bus idle condition, there are footprints on the evaluation boards for fitting the R2 pull-up resistor to V_{CC} on Pin A, as well as the R1 pull-down resistor to GND on Pin B. These resistors can be fitted if the user is connecting to other devices that require external biasing resistors on the bus. The exact value required for a 200 mV minimum differential voltage in bus idle condition depends on the supply voltage (for example, 960 Ω for 3.3 V and 1440 Ω for 5 V).

For more information about the bus idle fail-safe, see the [AN-960 Application Note, RS-485/RS-422 Circuit Implementation Guide](#).

Table 1. Jumper Configurations

Link	Jumper Connection	Description
LK1	A	Connects the receiver enable (\overline{RE}) input of the ADM3063E to V _{CC} . This setting disables the receiver.
	B	Connects the \overline{RE} input of the ADM3063E to GND. This setting enables the receiver.
	C	Connects the \overline{RE} input of the ADM3063E to the J3-2 terminal block connector.
	D	Connects the \overline{RE} input of the ADM3063E to the J3-3 terminal block connector; that is, the input for both \overline{RE} and DE is set by LK1. This setting ensures that when the driver is enabled, the receiver is disabled, or when the driver is disabled, the receiver is enabled.
LK2	A	Connects the DE input of the ADM3063E to V _{CC} . This setting enables the driver.
	B	Connects the DE input of the ADM3063E to GND. This setting disables the driver.
	C	Connects the DE input of the ADM3063E to the J3-2 terminal block connector.
LK3	Inserted	Connects the 120 Ω RT1 termination resistor across the A and B pins of the RS-485.
	Not inserted	Disconnects the 120 Ω RT1 termination resistor across the A and B pins of the RS-485.
LK5	Inserted	Connects the 120 Ω RT3 termination resistor across the Y and Z pins of the RS-485.
	Not inserted	Disconnects the 120 Ω RT3 termination resistor across the Y and Z pins of the RS-485.
LK6	Inserted	Connects Pin B to Pin Z.
	Not inserted	Disconnects Pin B from Pin Z.
LK4	Inserted	Connects Pin A to Pin Y.
	Not inserted	Disconnects Pin A from Pin Y.

FULL-DUPLEX RS-485 TRANSCEIVERS LOOPBACK TEST

For the EVAL-ADM3063EEBZ, a loopback test can be set up by closing the LK4 and LK6 jumpers. This test is shown in Figure 3. A signal generator is connected to the DI pin and this allows verification of the bus signals and the receiver output. Note the jumper positions of LK1 (B) and LK2 (A) for the EVAL-ADM3063EEBZ evaluation board. Ensure that LK3 and LK5 are also closed to loop back the transmitter outputs to the receiver inputs. In this configuration, the default termination resistors can be used, because both 120 Ω resistors on the board are connected in parallel by the loopback, ensuring that the test is conducted with a standard RS-485 load of 60 Ω (bus terminated at both ends by 120 Ω).

IEC 61000-4-2 ELECTROSTATIC DISCHARGE (ESD) PROTECTION TO ±12 kV (CONTACT) AND ±12 kV (AIR)

The EVAL-ADM3063EEBZ evaluation board is tested to achieve protection against IEC 61000-4-2 ESD to ±12 kV (contact), and ±12 kV (air) on the RS-485 A and B bus pins.

The IEC 61000-4-2 ESD standard describes testing using two coupling methods known as contact discharge and air discharge. Contact discharge implies a direct contact between the discharge gun and the equipment under test (EUT).

During air discharge testing, the charged electrode of the discharge gun is moved toward the EUT until a discharge occurs as an arc across the air gap. The discharge gun does not make direct contact with the EUT.

During testing, the A, B, Y, and Z pins of the EVAL-ADM3063EEBZ are subjected to at least 10 positive and 10 negative single discharges with a 1 sec interval between each pulse. The highest specified IEC 61000-4-2 ESD test is Level 4, which defines a contact discharge voltage of ±8 kV and an air discharge voltage of ±15 kV. Transceivers quoting IEC 61000-4-2 levels of protection, such as the ADM3063E, far exceed the robustness offered by transceivers with varying levels of Human Body Model (HBM) protection.

Figure 2 shows the 8 kV contact discharge current waveform as described in the ADM3063E data sheet. Some key IEC 61000-4-2 waveform parameters are rise times of <1 ns and pulse widths of ~60 ns.

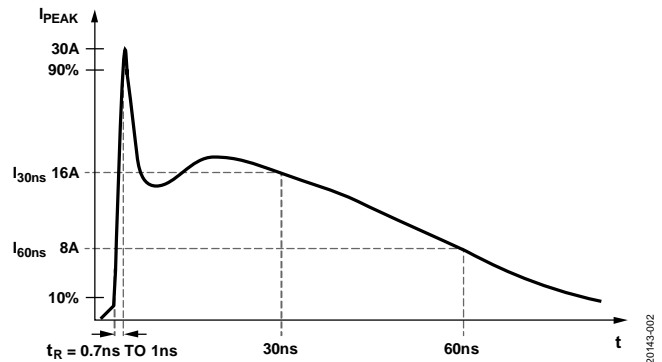

Figure 2. IEC 61000-4-2 ESD Waveform (8 kV)

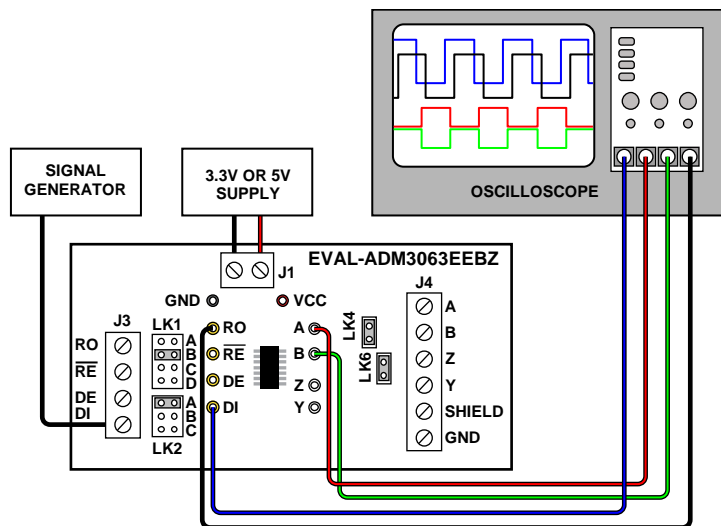

Figure 3. Full-Duplex RS-485 Loopback Test

EVALUATION BOARD SCHEMATICS AND ARTWORK

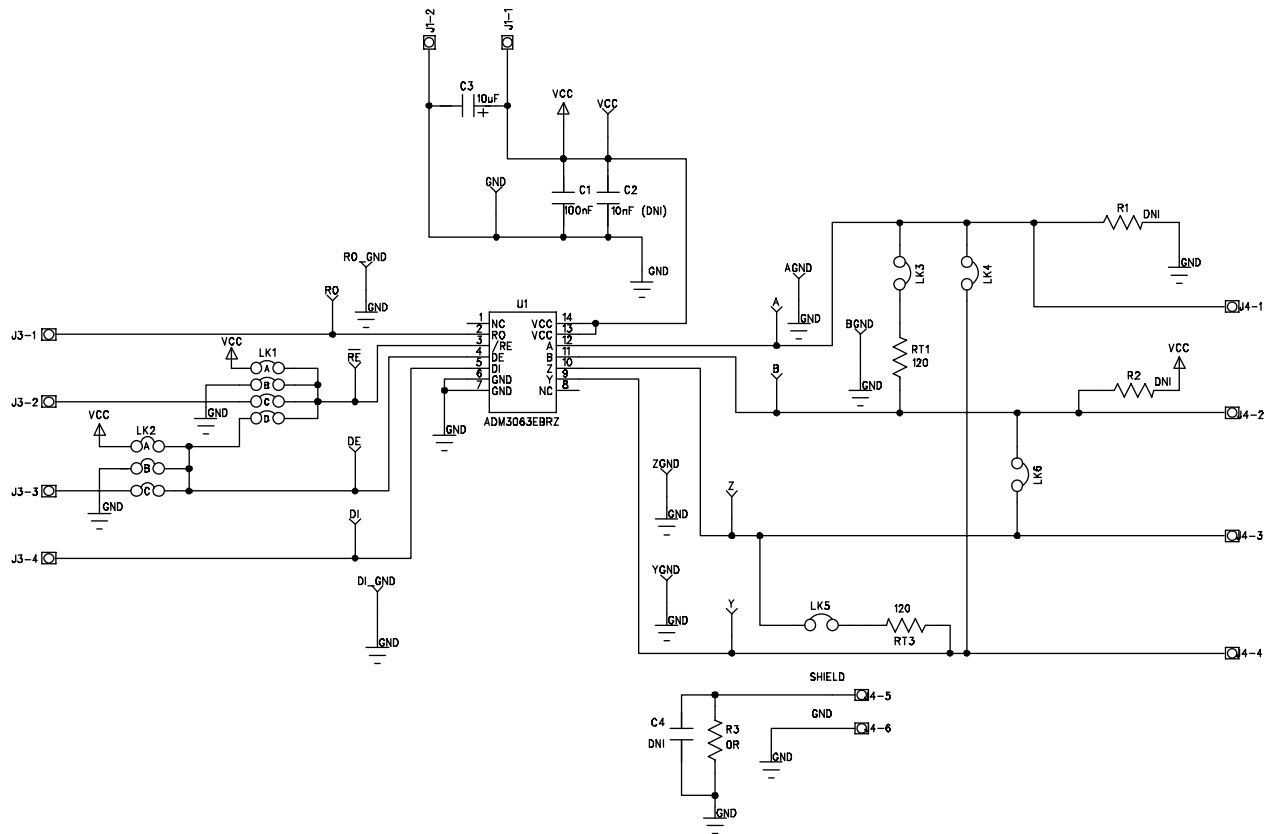

Figure 4. EVAL-ADM3063EEBZ Schematic

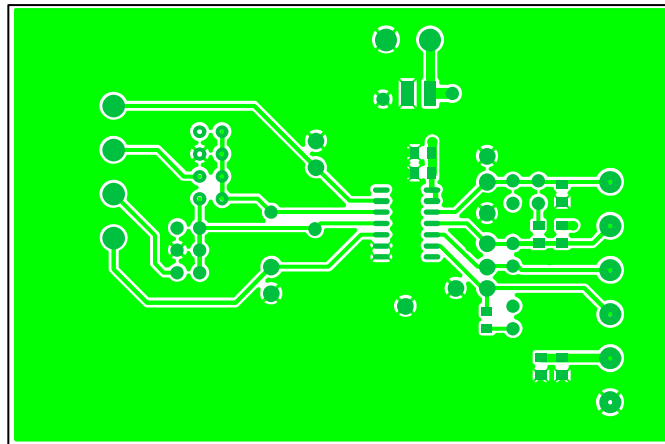
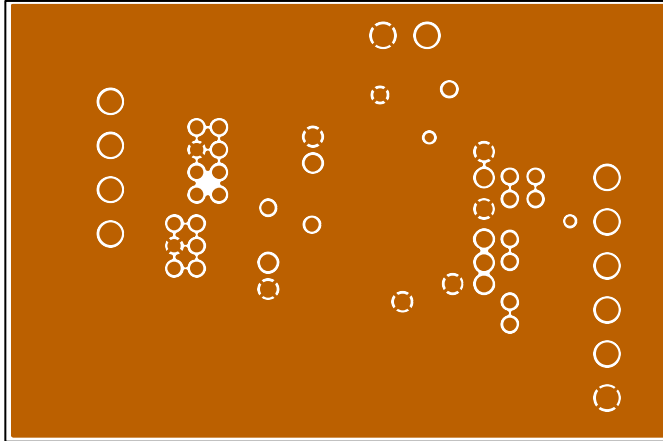
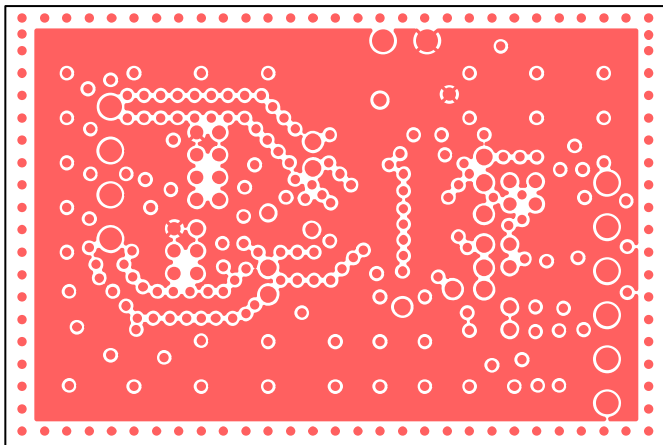

Figure 5. EVAL-ADM3063EEBZ Component Side, Layer 1



20143-006

Figure 6. EVAL-ADM3063EEBZ, Layer 2



20143-007

Figure 7. EVAL-ADM3063EEBZ, Layer 3

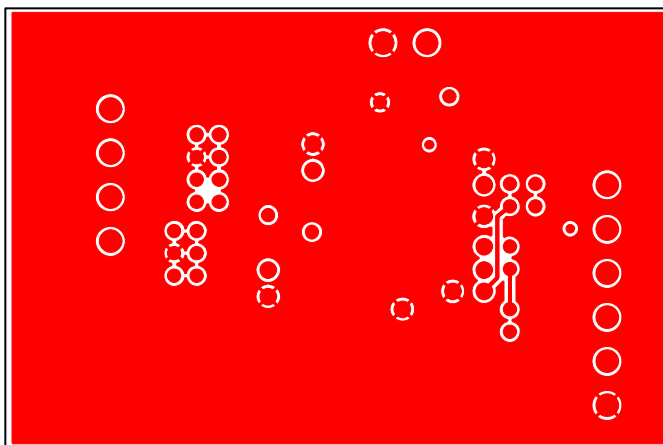

20143-008

Figure 8. EVAL-ADM3063EEBZ, Layer 4

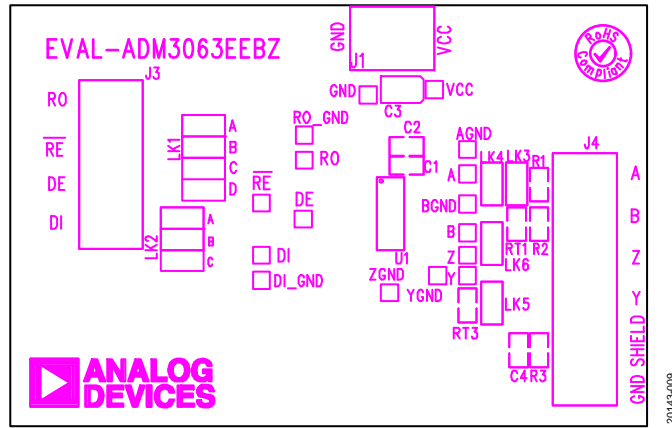

Figure 9. EVAL-ADM3063EEBZ, Silkscreen

ORDERING INFORMATION

BILL OF MATERIALS

Table 2.

Qty	Reference Designator	Description	Manufacturer	Part Number
1	C1	Capacitor, 100 nF, 0805	Multicomp	MCCA000274
2	C2, C4	Capacitor, not placed/optional	Not applicable	Not applicable
1	C3	Capacitor, 10 μ F, Case B	Kemet	B45196H3106K209
12	A, B, Y, Z, AGND, BGND, YGND, ZGND, DI, RO, DI_GND, RO_GND	High speed test point, silver pin	Oxley	040/30P/LA/KP2 SILVER
2	DE, RE	Test point, yellow	Vero Technologies	20-313140
1	GND	Test point, black	Vero Technologies	20-2137
1	J1	Two-way terminal block	Lumberg	KRM 02
1	J3	Four-way terminal block	Lumberg	KRM 04
1	J4	Six-way terminal block	Camden	CTB5000/6
1	LK1	8-pin (4 \times 2), 0.1 inch header and shorting block	Harwin	M20-9953646 and M7566-05
1	LK2	6-pin (3 \times 2), 0.1 inch header and shorting block	Harwin	M20-9953646 and M7566-05
4	LK3, LK4, LK5, LK6	Jumper block, 2-pin, 0.1 inch spacing	Harwin	M20-9990246 and M7566-05
2	R1, R2	Resistor, not placed/optional		Not applicable
1	R3	Resistor, 0 Ω , 0805	Vishay	CRCW08050000Z0EA
2	RT1, RT3	Resistor, 120 Ω , 0805	Multicomp	MC01W08051120R
1	U1	14-lead NSOIC	Analog Devices, Inc.	ADM3063EBRZ
2	VCC	Test point, red	Vero Technologies	20-313137

**ESD Caution**

ESD (electrostatic discharge) sensitive device. Charged devices and circuit boards can discharge without detection. Although this product features patented or proprietary protection circuitry, damage may occur on devices subjected to high energy ESD. Therefore, proper ESD precautions should be taken to avoid performance degradation or loss of functionality.

Legal Terms and Conditions

By using the evaluation board discussed herein (together with any tools, components documentation or support materials, the "Evaluation Board"), you are agreeing to be bound by the terms and conditions set forth below ("Agreement") unless you have purchased the Evaluation Board, in which case the Analog Devices Standard Terms and Conditions of Sale shall govern. Do not use the Evaluation Board until you have read and agreed to the Agreement. Your use of the Evaluation Board shall signify your acceptance of the Agreement. This Agreement is made by and between you ("Customer") and Analog Devices, Inc. ("ADI"), with its principal place of business at One Technology Way, Norwood, MA 02062, USA. Subject to the terms and conditions of the Agreement, ADI hereby grants to Customer a free, limited, personal, temporary, non-exclusive, non-sublicensable, non-transferable license to use the Evaluation Board FOR EVALUATION PURPOSES ONLY. Customer understands and agrees that the Evaluation Board is provided for the sole and exclusive purpose referenced above, and agrees not to use the Evaluation Board for any other purpose. Furthermore, the license granted is expressly made subject to the following additional limitations: Customer shall not (i) rent, lease, display, sell, transfer, assign, sublicense, or distribute the Evaluation Board; and (ii) permit any Third Party to access the Evaluation Board. As used herein, the term "Third Party" includes any entity other than ADI, Customer, their employees, affiliates and in-house consultants. The Evaluation Board is NOT sold to Customer; all rights not expressly granted herein, including ownership of the Evaluation Board, are reserved by ADI. CONFIDENTIALITY. This Agreement and the Evaluation Board shall all be considered the confidential and proprietary information of ADI. Customer may not disclose or transfer any portion of the Evaluation Board to any other party for any reason. Upon discontinuation of use of the Evaluation Board or termination of this Agreement, Customer agrees to promptly return the Evaluation Board to ADI. ADDITIONAL RESTRICTIONS. Customer may not disassemble, decompile or reverse engineer chips on the Evaluation Board. Customer shall inform ADI of any occurred damages or any modifications or alterations it makes to the Evaluation Board, including but not limited to soldering or any other activity that affects the material content of the Evaluation Board. Modifications to the Evaluation Board must comply with applicable law, including but not limited to the RoHS Directive. TERMINATION. ADI may terminate this Agreement at any time upon giving written notice to Customer. Customer agrees to return to ADI the Evaluation Board at that time. LIMITATION OF LIABILITY. THE EVALUATION BOARD PROVIDED HEREUNDER IS PROVIDED "AS IS" AND ADI MAKES NO WARRANTIES OR REPRESENTATIONS OF ANY KIND WITH RESPECT TO IT. ADI SPECIFICALLY DISCLAIMS ANY REPRESENTATIONS, ENDORSEMENTS, GUARANTEES, OR WARRANTIES, EXPRESS OR IMPLIED, RELATED TO THE EVALUATION BOARD INCLUDING, BUT NOT LIMITED TO, THE IMPLIED WARRANTY OF MERCHANTABILITY, TITLE, FITNESS FOR A PARTICULAR PURPOSE OR NON-INFRINGEMENT OF INTELLECTUAL PROPERTY RIGHTS. IN NO EVENT WILL ADI AND ITS LICENSORS BE LIABLE FOR ANY INCIDENTAL, SPECIAL, INDIRECT, OR CONSEQUENTIAL DAMAGES RESULTING FROM CUSTOMER'S POSSESSION OR USE OF THE EVALUATION BOARD, INCLUDING BUT NOT LIMITED TO LOST PROFITS, DELAY COSTS, LABOR COSTS OR LOSS OF GOODWILL. ADI'S TOTAL LIABILITY FROM ANY AND ALL CAUSES SHALL BE LIMITED TO THE AMOUNT OF ONE HUNDRED US DOLLARS (\$100.00). EXPORT. Customer agrees that it will not directly or indirectly export the Evaluation Board to another country, and that it will comply with all applicable United States federal laws and regulations relating to exports. GOVERNING LAW. This Agreement shall be governed by and construed in accordance with the substantive laws of the Commonwealth of Massachusetts (excluding conflict of law rules). Any legal action regarding this Agreement will be heard in the state or federal courts having jurisdiction in Suffolk County, Massachusetts, and Customer hereby submits to the personal jurisdiction and venue of such courts. The United Nations Convention on Contracts for the International Sale of Goods shall not apply to this Agreement and is expressly disclaimed.



Компания «ЭлектроПласт» предлагает заключение долгосрочных отношений при поставках импортных электронных компонентов на взаимовыгодных условиях!

Наши преимущества:

- Оперативные поставки широкого спектра электронных компонентов отечественного и импортного производства напрямую от производителей и с крупнейших мировых складов;
- Поставка более 17-ти миллионов наименований электронных компонентов;
- Поставка сложных, дефицитных, либо снятых с производства позиций;
- Оперативные сроки поставки под заказ (от 5 рабочих дней);
- Экспресс доставка в любую точку России;
- Техническая поддержка проекта, помощь в подборе аналогов, поставка прототипов;
- Система менеджмента качества сертифицирована по Международному стандарту ISO 9001;
- Лицензия ФСБ на осуществление работ с использованием сведений, составляющих государственную тайну;
- Поставка специализированных компонентов (Xilinx, Altera, Analog Devices, Intersil, Interpoint, Microsemi, Aeroflex, Peregrine, Syfer, Eurofarad, Texas Instrument, Miteq, Cobham, E2V, MA-COM, Hittite, Mini-Circuits, General Dynamics и др.);

Помимо этого, одним из направлений компании «ЭлектроПласт» является направление «Источники питания». Мы предлагаем Вам помощь Конструкторского отдела:

- Подбор оптимального решения, техническое обоснование при выборе компонента;
- Подбор аналогов;
- Консультации по применению компонента;
- Поставка образцов и прототипов;
- Техническая поддержка проекта;
- Защита от снятия компонента с производства.



Как с нами связаться

Телефон: 8 (812) 309 58 32 (многоканальный)

Факс: 8 (812) 320-02-42

Электронная почта: org@eplast1.ru

Адрес: 198099, г. Санкт-Петербург, ул. Калинина, дом 2, корпус 4, литера А.