

Product Specification

100m Multirate Parallel MMF 100/128G QSFP28 Optical Transceiver

FTLC9551SEPM

PRODUCT FEATURES

- Hot-pluggable QSFP28 form factor
- Supports 103.1Gb/s to 112.2Gb/s aggregate bit rates
- Power dissipation < 3.5W
- RoHS-6 compliant
- Commercial case temperature range of 0°C to 70°C
- Single 3.3V power supply
- Maximum link length of 100m on OM4 Multimode Fiber (MMF)
- 4x25Gb/s 850nm VCSEL-based transmitter
- 4x25G electrical interface
- Single MPO12 receptacle
- I2C management interface

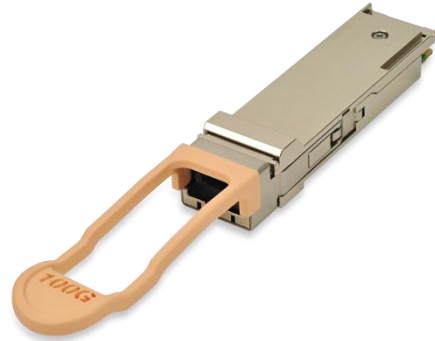

APPLICATIONS

- 100GBASE-SR4 100G Ethernet
- 128G Fibre Channel
- 4x28Gb/s Multimode OTN

Finisar's FTLC9551SEPM 100G QSFP28 transceiver modules are designed for use in 100 Gigabit Ethernet, 128GFC and 4x28G OTN client links over multimode fiber. They are compliant with the QSFP28 MSA¹, 128GFC² and IEEE 802.3bm 100GBASE-SR4³ and CAUI-4³. Digital diagnostics functions are available via the I2C interface, as specified by the QSFP28 MSA¹ and Finisar Application Note AN-2142⁴. The transceiver is RoHS-6 compliant per Directive 2011/65/EU⁵ and Finisar Application Note AN-2038⁶.

PRODUCT SELECTION

FTLC9551SEPM

- S: 128GFC maximum bit rate (112.2 Gb/s)
- E: 4x25G parallel optics
- P: Pull tab release
- M: MPO receptacle

I. Pin Descriptions

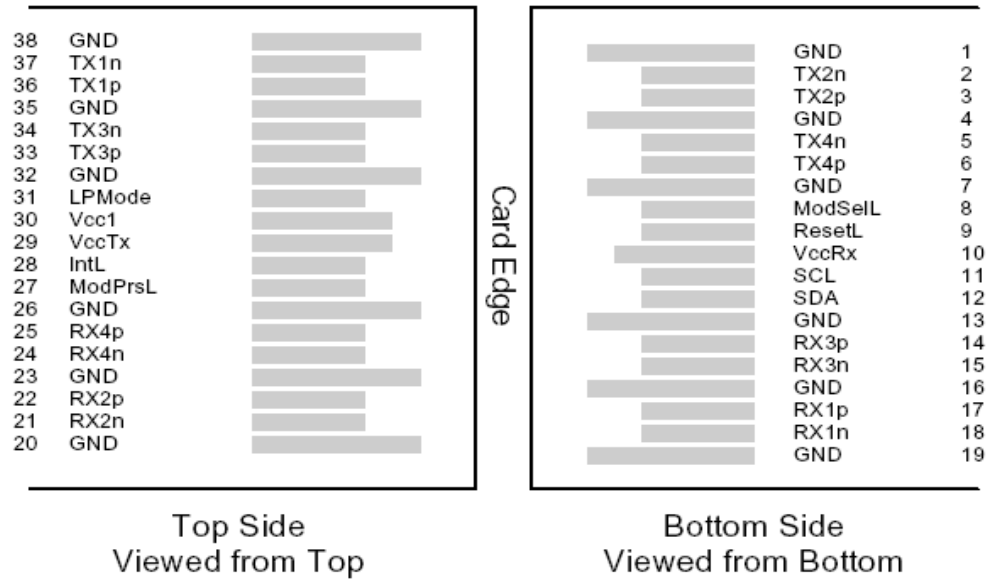

Figure 1 – QSFP28-compliant 38-pin connector (per SFF-8679)

Pin	Symbol	Name/Description	Notes
1	GND	Ground	1
2	Tx2n	Transmitter Inverted Data Input	
3	Tx2p	Transmitter Non-Inverted Data Input	
4	GND	Ground	1
5	Tx4n	Transmitter Inverted Data Input	
6	Tx4p	Transmitter Non-Inverted Data Input	
7	GND	Ground	1
8	ModSelL	Module Select	
9	ResetL	Module Reset	
10	Vcc Rx	+3.3 V Power supply receiver	
11	SCL	2-wire serial interface clock	
12	SDA	2-wire serial interface data	
13	GND	Ground	1
14	Rx3p	Receiver Non-Inverted Data Output	
15	Rx3n	Receiver Inverted Data Output	
16	GND	Ground	1
17	Rx1p	Receiver Non-Inverted Data Output	
18	Rx1n	Receiver Inverted Data Output	
19	GND	Ground	1
20	GND	Ground	1
21	Rx2n	Receiver Inverted Data Output	
22	Rx2p	Receiver Non-Inverted Data Output	
23	GND	Ground	1
24	Rx4n	Receiver Inverted Data Output	
25	Rx4p	Receiver Non-Inverted Data Output	
26	GND	Ground	1
27	ModPrsL	Module Present	
28	IntL	Interrupt	
29	Vcc Tx	+3.3 V Power supply transmitter	

30	Vcc1	+3.3 V Power Supply	
31	LPMODE	Low Power Mode	
32	GND	Ground	1
33	Tx3p	Transmitter Non-Inverted Data Input	
34	Tx3n	Transmitter Inverted Data Input	
35	GND	Ground	1
36	Tx1p	Transmitter Non-Inverted Data Input	
37	Tx1n	Transmitter Inverted Data Input	
38	GND	Ground	1

Notes

1. Circuit ground is internally isolated from chassis ground.

II. Absolute Maximum Ratings

Module performance is not guaranteed beyond the operating range (see Section VI). Exceeding the limits below may damage the transceiver module permanently.

Parameter	Symbol	Min	Typ	Max	Unit	Ref.
Maximum Supply Voltage	V _{CC}	-0.5		4.0	V	
Storage Temperature	T _S	-40		85	°C	
Case Operating Temperature	T _{OP}	-5		75	°C	
Relative Humidity	RH	15		85	%	1
Receiver Damage Threshold, per Lane	P _{Rdmg}	5.5			dBm	

Notes:

1. Non-condensing.

III. Electrical Characteristics (EOL, T_{OP} = 0 to 70 °C, V_{CC} = 3.135 to 3.465 Volts)

Parameter	Symbol	Min	Typ	Max	Unit	Ref.
Supply Voltage	V _{CC}	3.135		3.465	V	
Supply Current	I _{CC}			1.5	A	
Module total power	P			3.5	W	1
Transmitter						
Signaling rate per lane		25.78		28.05	Gb/s	2
Differential data input voltage per lane	V _{in,pp,diff}			900	mV	
Single-ended voltage tolerance	V _{in,pp}	-0.35		+3.3	V	
Module stress input test		Per Section 13.3.11.2.1, OIF CEI-28G-VSR				
Receiver						
Signaling rate per lane		25.78		28.05	Gb/s	2
Differential data output swing	V _{out,pp}	100		400	mVpp	3
		300		600		
		400	600	800		
		600		1200		
Eye width		0.57			UI	
Eye height, differential		228			mV	
Vertical eye closure	VEC	5.5			dB	
Transition time (20% to 80%)	t _r , t _f	12			ps	

Notes:

1. Maximum total power value is specified across the full operational temperature and voltage range when CDRs are locked or a lack of input signal results in squelch being activated. If incorrect frequencies cause the CDRs to continuously attempt to lock, maximum power dissipation may reach 4.5 W.
2. ± 100 ppm
3. Output voltage is settable in 4 discrete ranges via I2C. Default range is 400 – 800 mV.

IV. Optical Characteristics (EOL, T_{OP} = 0 to 70°C, V_{CC} = 3.135 to 3.465 Volts)

Optical characteristics are dependent on data rate and protocol. Ethernet 100GBASE-SR4, OTU4, and 128G Fibre Channel optical characteristics are as follows:

100GBASE-SR4 Ethernet Operation

Parameter	Symbol	Min	Typ	Max	Unit	Ref.
Transmitter						
Signaling Speed per Lane		25.78125 \pm 100ppm			Gb/s	1
Center wavelength		840		860	nm	
RMS Spectral Width	SW			0.6	nm	
Average Launch Power per Lane	TXP _x	-8.4		2.4	dBm	
Transmit OMA per Lane	TxOMA	-6.4		3	dBm	
Launch Power [OMA] minus TDEC per Lane	P-TDEC	-7.3			dBm	
TDEC per Lane	TDEC			4.3	dBm	
Optical Extinction Ratio	ER	2			dB	
Optical Return Loss Tolerance	ORL			12	dB	
Encircled Flux	FLX	>86% at 19 μ m <30% at 4.5 μ m				
Average Launch Power of OFF Transmitter, per Lane				-30	dBm	
Relative Intensity Noise	RIN				dB/Hz	
Transmitter Eye mask definition {X1, X2, X3, Y1, Y2, Y3}		{0.3,0.38,0.45,0.35,0.41,0.5}				2
Receiver						
Signaling Speed per Lane		25.78125 \pm 100ppm			GBd	3
Center wavelength		840		860	nm	
Damage Threshold	DT	3.4			dBm	
Average Receive Power per Lane	RXP _x	-10.3		2.4	dBm	4
Receive Power (OMA) per Lane	RxOMA			3	dBm	
Receiver Reflectance	Rfl			-12	dB	
Stressed Receiver Sensitivity (OMA) per Lane	SRS			-5.2	dBm	
Stressed Conditions:						
Stressed Eye Closure	SEC		4.3		dB	
Stressed Eye J2 Jitter	J2		0.39		UI	
Stressed Eye J4 Jitter	J4		0.53		UI	
OMA of each aggressor lane			3		dBm	
Stressed Receiver Eye Mask Definition {X1, X2, X3, Y1, Y2, Y3}		{0.28,0.5,0.5,0.33,0.33,0.4}				5
LOS De-Assert	LOS _D			-12	dBm	
LOS Assert	LOS _A	-30			dBm	
LOS Hysteresis		0.5	2		dB	

Notes:

1. Transmitter consists of 4 lasers operating at a maximum speed of 25.78125Gb/s \pm 100ppm each.
2. Hit Ratio 1.5×10^{-3} hits/sample.
3. Receiver consists of 4 photodetectors operating at a maximum speed of 25.78125Gb/s \pm 100ppm each.
4. Minimum value is informative only and not the principal indicator of signal strength.
5. Hit Ratio 5×10^{-5} hits/sample.

OTU4 and 128 G Fibre Channel Operation

Parameter	Symbol	Min	Typ	Max	Unit	Ref.
Transmitter						
Signaling Speed per Lane		27.95		28.05	Gb/s	4
Center wavelength		840		860	nm	
RMS Spectral Width	SW			0.6	nm	
Average Launch Power per Lane	TXP _x	-9		2.4	dBm	
Transmit OMA per Lane	TxOMA	-7.1		3.0	dBm	
Launch Power [OMA] minus TDEC per Lane	P-TDEC	-8.0			dBm	
TDEC per Lane	TDEC			5.0	dB	
Optical Extinction Ratio	ER	3			dB	
Encircled Flux	FLX	>86% at 19um, <30% at 4.5um			dBm	
Average launch power of OFF transmitter, per lane				-30	dBm	
Transmitter eye mask definition {X1, X2, X3, Y1, Y2, Y3}		{0.31,0.41,0.46, 0.35,0.38,0.50}				5
Optical Return Loss Tolerance	ORL			12	dB	
Receiver						
Signaling Speed per Lane		27.95		28.05	Gb/s	6
Center wavelength		840		860	nm	
Damage Threshold	DT	3.4			dBm	
Average Receive Power per Lane	RXP _x	-10.9		2.4	dBm	7
Receive Power (OMA) per Lane	RxOMA			3.0	dBm	
Receiver Reflectance	Rfl			-12	dB	
Stressed Receiver Sensitivity (OMA) per Lane	SRS			-4.7	dBm	8
Stressed receiver eye mask definition {X1, X2, X3, Y1, Y2, Y3}		{0.29,0.50,0.50, 0.35,0.35,0.40}				9
LOS De-Assert	LOS _D			-13	dBm	
LOS Assert	LOS _A	-30			dBm	
LOS Hysteresis		0.5	2		dB	

Notes:

6. Transmitter consists of 4 lasers operating at a maximum speed of 27.95 Gb/s each for OTU4 and 28.05 Gb/s each for Fibre Channel.
7. Hit ratio = 1.5×10^{-3} hits/sample.
8. Receiver consists of 4 photodetectors operating at a maximum speed of 27.95 Gb/s each for OTU4 and 28.05 Gb/s each for Fibre Channel.
9. Minimum value is informative only and not the principal indicator of signal strength.
10. Test conditions for measuring SRS are defined as follows:

Stressed eye closure, lane under test	SEC		5.0		dB	
Stressed eye J2 jitter, lane under test	J2		0.38		UI	
Stressed eye J4 jitter, lane under test	J4		0.51		UI	
OMA of each aggressor lane			3		dBm	

Stressed Eye Closure (SEC) is measured per IEEE 802.3 95.8.8 (reference [22]), but adjusted to 1×10^{-6} instead of 1×10^{-5} bit error ratio. Thus SEC is given by $SEC = 10 \log_{10} [OMA / (2 * 4.2649 * R)]$ with R as defined by equation (95-3) in 95.8.5, The values of M1 and M2 in equation (95-3) are set to zero. The combination of the O/E and the oscilloscope used to measure the waveform has a fourth-order Bessel-Thomson filter response with a bandwidth of 19.34 GHz.

11. Hit ratio = 1×10^{-5} hits/sample.

V. General Specifications

Parameter	Symbol	Min	Typ	Max	Units	Ref.
Bit Rate (all wavelengths combined)	BR			112.2	Gb/s	1
Bit Error Ratio @25.78Gb/s	BER1			5×10^{-5}		2
Bit Error Ratio @27.95Gb/s	BER2			10^{-6}		3
Bit Error Ratio @28.05Gb/s	BER3			5×10^{-5}		2
Maximum Supported Distances						
Fiber Type						
OM3 MMF	Lmax1			70	m	4
OM4 MMF	Lmax2			100	m	4

Notes:

- Supports 128GFC per T11, 4x28G multimode OTN and 100GBASE-SR4 per IEEE 802.3bm.
- Tested with a $2^{31} - 1$ PRBS.
- Tested with a $2^{31} - 1$ PRBS. The BER of 10^{-12} for the OTU4 (112 Gb/s) application code is required to be met only after forward error correction has been applied. ITU-T G.sup39 defines the pre-FEC BER to be met as 10^{-6} . The values for receiver sensitivity and optical path penalty measured at the receiver output at a BER of 10^{-6} will normally be conservative estimates of the values for receiver sensitivity and path penalty at the BER of 10^{-12} after the FEC decoder.
- Requires FEC on the host to support maximum distance.

VI. Environmental Specifications

Finisar FTLC9551 QSFP28 transceivers have a commercial operating case temperature range of 0°C to $+70^{\circ}\text{C}$. They can support temporary excursions to case temperatures of -5°C and $+75^{\circ}\text{C}$ without permanent damage (see Section II).

Parameter	Symbol	Min	Typ	Max	Units	Ref.
Case Operating Temperature	T_{op}	0		70	$^{\circ}\text{C}$	
Storage Temperature	T_{sto}	-40		85	$^{\circ}\text{C}$	

VII. Regulatory Compliance

Finisar FTLC9551 QSFP28 transceivers are Class 1 Laser Products. They are certified per the following standards:

Feature	Agency	Standard
Laser Eye Safety	FDA/CDRH	CDRH 21 CFR 1040 and Laser Notice 50
Laser Eye Safety	TÜV	EN 60825-1:2007 EN 60825-2:2004+A1+A2
Electrical Safety	TÜV	EN 60950
Electrical Safety	UL/CSA	CLASS 3862.07 CLASS 3862.87

Copies of the referenced certificates will be available at Finisar upon request.

Complies with FDA performance standards for laser products except for deviations pursuant to Laser Notice No. 50, dated June 24, 2007.

VIII. Digital Diagnostics Functions

FTLC9551 QSFP28 transceivers support the I2C-based diagnostics interface specified by the QSFP28 MSA¹. See Finisar Application Note AN-2142 (Title TBD)⁴.

IX. Memory Contents

Per the QSFP28 MSA¹. See Finisar Application Note AN-2142 (Title TBD)⁴.

XI. Mechanical Specifications

Finisar FTLC9551 QSFP28 transceivers are compatible with the QSFP28 MSA specification¹.

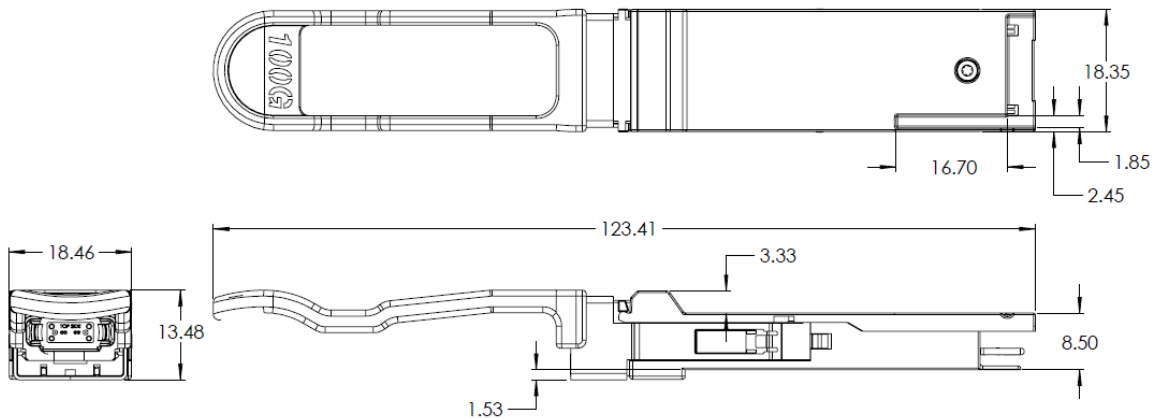

Figure 2. FTLC9551SEPM Mechanical Dimensions.

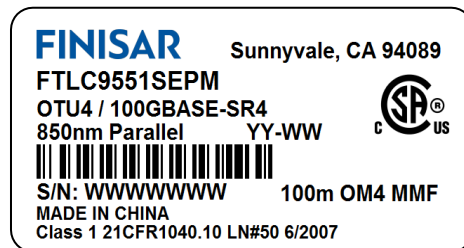

Figure 3. Product Label

XII. References

1. SFF-8665: “QSFP+ 28Gb/s 4X Pluggable Transceiver Solution (QSFP28)”, Rev 1.9, June 29, 2015 (and associated SFF documents referenced therein)
 - i. SFF-8661
 - ii. SFF-8679
 - iii. SFF-8636
 - iv. SFF-8662
 - v. SFF-8663
 - vi. SFF-8672
 - vii. SFF-8683
2. 128GFC Specification, per ANSI T.11 FC-PI-6P.
3. IEEE 802.3bm, PMD Type 100GBASE-SR4 and CAUI-4.
4. Application Note AN-2042 (TBD), Finisar Corporation.
5. Directive 2011/65/EU of the European Parliament and of the Council, “on the restriction of the use of certain hazardous substances in electrical and electronic equipment,” July 1, 2011.
6. “Application Note AN-2038: Finisar Implementation Of RoHS Compliant Transceivers”, Finisar Corporation, January 21, 2005.

For More Information:

Finisar Corporation
1389 Moffett Park Drive
Sunnyvale, CA 94089-1133
Tel. 1-408-548-1000
Fax 1-408-541-6138
sales@finisar.com
www.finisar.com



Компания «ЭлектроПласт» предлагает заключение долгосрочных отношений при поставках импортных электронных компонентов на взаимовыгодных условиях!

Наши преимущества:

- Оперативные поставки широкого спектра электронных компонентов отечественного и импортного производства напрямую от производителей и с крупнейших мировых складов;
- Поставка более 17-ти миллионов наименований электронных компонентов;
- Поставка сложных, дефицитных, либо снятых с производства позиций;
- Оперативные сроки поставки под заказ (от 5 рабочих дней);
- Экспресс доставка в любую точку России;
- Техническая поддержка проекта, помощь в подборе аналогов, поставка прототипов;
- Система менеджмента качества сертифицирована по Международному стандарту ISO 9001;
- Лицензия ФСБ на осуществление работ с использованием сведений, составляющих государственную тайну;
- Поставка специализированных компонентов (Xilinx, Altera, Analog Devices, Intersil, Interpoint, Microsemi, Aeroflex, Peregrine, Syfer, Eurofarad, Texas Instrument, Miteq, Cobham, E2V, MA-COM, Hittite, Mini-Circuits, General Dynamics и др.);

Помимо этого, одним из направлений компании «ЭлектроПласт» является направление «Источники питания». Мы предлагаем Вам помощь Конструкторского отдела:

- Подбор оптимального решения, техническое обоснование при выборе компонента;
- Подбор аналогов;
- Консультации по применению компонента;
- Поставка образцов и прототипов;
- Техническая поддержка проекта;
- Защита от снятия компонента с производства.



Как с нами связаться

Телефон: 8 (812) 309 58 32 (многоканальный)

Факс: 8 (812) 320-02-42

Электронная почта: org@eplast1.ru

Адрес: 198099, г. Санкт-Петербург, ул. Калинина, дом 2, корпус 4, литера А.