

TJA1048

Dual high-speed CAN transceiver with Standby mode

Rev. 6 — 19 March 2018

Product data sheet

1. General description

The TJA1048 is a dual high-speed CAN transceiver that provides an interface between a Controller Area Network (CAN) protocol controller and the physical two-wire CAN bus. The transceiver is designed for high-speed CAN applications in the automotive industry, providing the differential transmit and receive capability to (a microcontroller with) a CAN protocol controller.

The TJA1048 belongs to the third generation of high-speed CAN transceivers from NXP Semiconductors, offering significant improvements over first- and second-generation devices such as the TJA1040. It offers improved Electro Magnetic Compatibility (EMC) and ElectroStatic Discharge (ESD) performance, and also features:

- Ideal passive behavior to the CAN bus when the supply voltage is off
- A very low-current Standby mode with bus wake-up capability on both channels
- Can be interfaced directly to microcontrollers with supply voltages from 3 V to 5 V

The TJA1048 implements the CAN physical layer as defined in ISO 11898-2:2016 and SAE J2284-1 to SAE J2284-5. This implementation enables reliable communication in the CAN FD fast phase at data rates up to 5 Mbit/s.

These features make the TJA1048 an excellent choice for all types of HS-CAN networks containing more than one HS-CAN interface that require a low-power mode with wake-up capability via the CAN bus, especially for Body Control and Gateway units.

2. Features and benefits

2.1 General

- Two TJA1042/3 HS-CAN transceivers combined monolithically in a single package
- ISO 11898-2:2016 and SAE J2284-1 to SAE J2284-5 compliant
- Timing guaranteed for data rates up to 5 Mbit/s in the CAN FD fast phase
- Suitable for 12 V and 24 V systems
- Low ElectroMagnetic Emission (EME) and high ElectroMagnetic Immunity (EMI)
- V_{IO} input allows for direct interfacing with 3 V to 5 V microcontrollers
- Available in SO14 and HVSON14 packages
- Leadless HVSON14 package (3.0 mm × 4.5 mm) with improved Automated Optical Inspection (AOI) capability
- Dark green product (halogen free and Restriction of Hazardous Substances (RoHS) compliant)
- AEC-Q100 qualified



2.2 Low-power management

- Very low-current Standby mode with host and bus wake-up capability
- Functional behavior predictable under all supply conditions
- Transceiver disengages from the bus when not powered up (zero load)
- Wake-up receiver powered by V_{IO} ; allows shut down of V_{CC}

2.3 Protection

- High ESD handling capability on the bus pins
- Bus pins protected against transients in automotive environments
- Transmit Data (TXD) dominant time-out function
- Undervoltage detection on pins V_{CC} and V_{IO}
- Thermally protected

3. Quick reference data

Table 1. Quick reference data

| Symbol | Parameter | Conditions | Min | Typ | Max | Unit |
|----------------|--|---------------------------------------|-----|------|------|--------------|
| V_{CC} | supply voltage | | 4.5 | - | 5.5 | V |
| V_{IO} | supply voltage on pin V_{IO} | | 2.8 | - | 5.5 | V |
| $V_{uvd(VCC)}$ | undervoltage detection voltage on pin V_{CC} | | 3.5 | - | 4.5 | V |
| $V_{uvd(VIO)}$ | undervoltage detection voltage on pin V_{IO} | | 1.3 | 2.0 | 2.7 | V |
| I_{CC} | supply current | Standby mode | - | 0.5 | 2 | μ A |
| | | Normal mode | | | | |
| | | both channels recessive | - | - | 20 | mA |
| | | one channel dominant | - | - | 80 | mA |
| I_{IO} | supply current on pin V_{IO} | Standby mode; $V_{TXD} = V_{IO}$ | - | 16.5 | 26 | μ A |
| | | Normal mode | | | | |
| | | both channels recessive | - | - | 35 | μ A |
| | | one channel dominant | - | - | 300 | μ A |
| V_{ESD} | electrostatic discharge voltage | IEC 61000-4-2 at pins CANHx and CANLx | -6 | - | +6 | kV |
| | | | | | | |
| V_{CANH} | voltage on pin CANH | pins CANH1 and CANH2 | -58 | - | +58 | V |
| V_{CANL} | voltage on pin CANL | pins CANL1 and CANL2 | -58 | - | +58 | V |
| T_{vj} | virtual junction temperature | | -40 | - | +150 | $^{\circ}$ C |

4. Ordering information

Table 2. Ordering information

| Type number | Package | | |
|-------------|---------|---|-----------|
| | Name | Description | Version |
| TJA1048T | SO14 | plastic small outline package; 14 leads; body width 3.9 mm | SOT108-1 |
| TJA1048TK | HVSON14 | plastic, thermal enhanced very thin small outline package; no leads; 14 terminals; body 3 × 4.5 × 0.85 mm | SOT1086-2 |

5. Block diagram

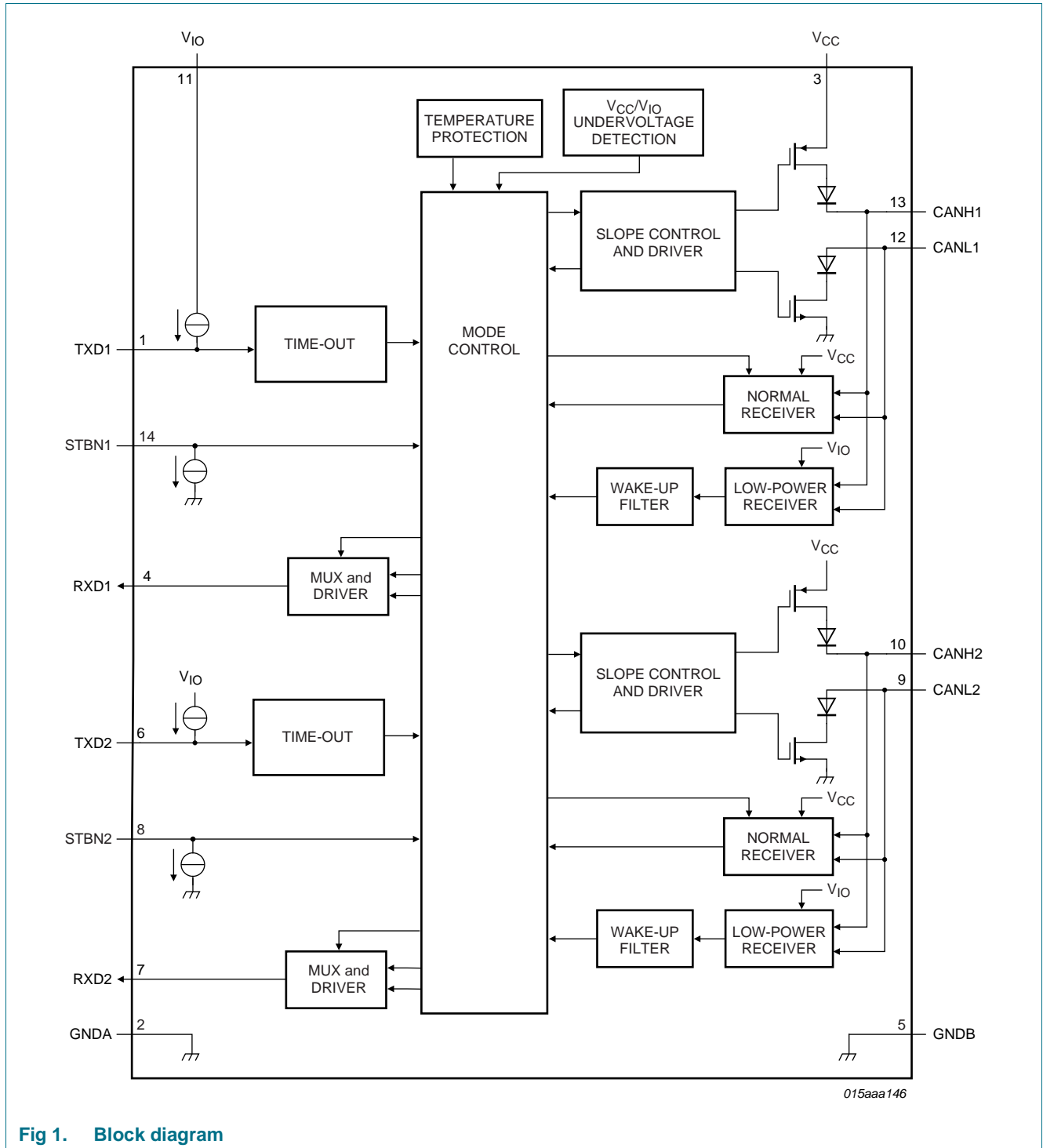

Fig 1. Block diagram

6. Pinning information

6.1 Pinning

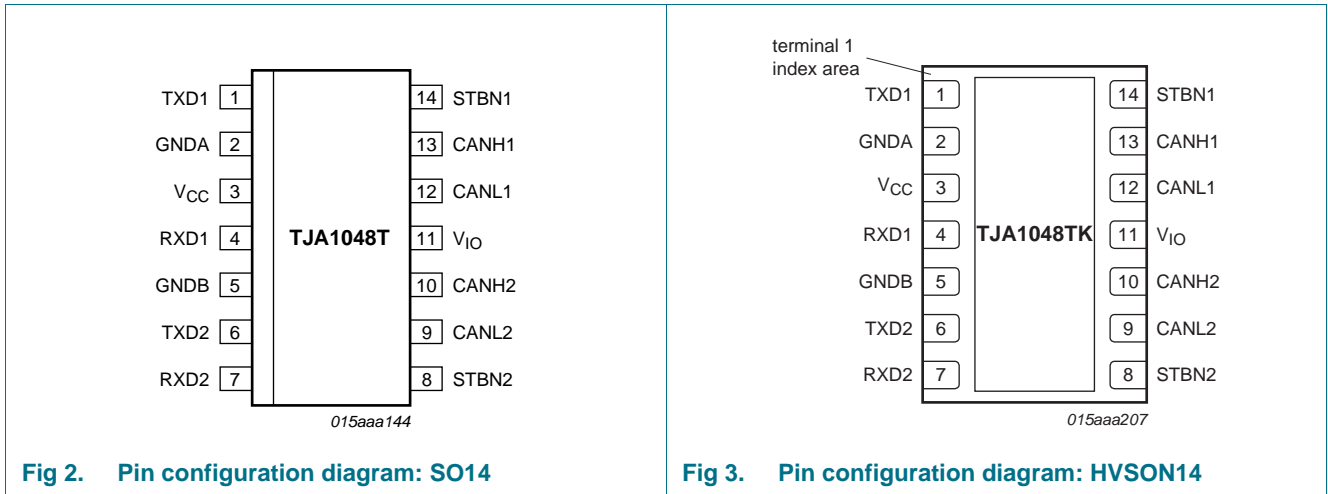

Fig 2. Pin configuration diagram: SO14

Fig 3. Pin configuration diagram: HVSON14

6.2 Pin description

Table 3. Pin description

| Symbol | Pin | Description |
|-----------------|------------------|--|
| TXD1 | 1 | transmit data input 1 |
| GNDA | 2 ^[1] | transceiver ground |
| V _{CC} | 3 | transceiver supply voltage |
| RXD1 | 4 | receive data output 1; reads out data from bus line1 |
| GNDB | 5 ^[1] | transceiver ground |
| TXD2 | 6 | transmit data input 2 |
| RXD2 | 7 | receive data output 2; reads out data from bus line 2 |
| STBN2 | 8 | standby control input 2 (HIGH = Normal mode, LOW = Standby mode) |
| CANL2 | 9 | LOW-level CAN bus line 2 |
| CANH2 | 10 | HIGH-level CAN bus line 2 |
| V _{IO} | 11 | supply voltage for I/O level adapter |
| CANL1 | 12 | LOW-level CAN bus line 1 |
| CANH1 | 13 | HIGH-level CAN bus line 1 |
| STBN1 | 14 | standby control input 1 (HIGH = Normal mode, LOW = Standby mode) |

[1] Pins 2 and 5 must be connected together externally in the application. HVSON14 package die supply ground is connected to both the GND pin and the exposed center pad. The GND pin must be soldered to board ground. For enhanced thermal and electrical performance, it is recommended that the exposed center pad also be soldered to board ground.

7. Functional description

The TJA1048 is a dual HS-CAN stand-alone transceiver with Standby mode and robust ESD handling capability. It combines the functionality of two TJA1042/3 transceivers with improved EMC and quiescent current performance. Improved slope control and high DC handling capability on the bus pins provide additional application flexibility.

7.1 Operating modes

The TJA1048 supports two operating modes per transceiver, Normal and Standby. The operating mode can be selected independently for each transceiver via pins STBN1 and STBN2 (see [Table 4](#)).

Table 4. Operating modes

| Mode | Pin STBN1/STBN2 | Pin RXD1/RXD2 | |
|---------|-----------------|--------------------------|-----------------------------|
| | | LOW | HIGH |
| Normal | HIGH | bus dominant | bus recessive |
| Standby | LOW | wake-up request detected | no wake-up request detected |

7.1.1 Normal mode

A HIGH level on pin STBN1/STBN2 selects Normal mode. In this mode, the transceiver can transmit and receive data via the bus lines CANH1/CANL1 and CANH2/CANL2 (see [Figure 1](#) for the block diagram). The differential receiver converts the analog data on the bus lines into digital data which is output on pin RXD1/RXD2. The slopes of the output signals on the bus lines are controlled internally and are optimized in a way that guarantees the lowest possible EME.

7.1.2 Standby mode

A LOW level on pin STBN1/STBN2 selects Standby mode. In Standby mode, the transceiver is not able to transmit or correctly receive data via the bus lines. The transmitter and Normal-mode receiver blocks are switched off to reduce supply current, and only a low-power differential receiver monitors the bus lines for activity.

In Standby mode, the bus lines are biased to ground to minimize the system supply current. The low-power receiver is supplied by V_{IO} , and is capable of detecting CAN bus activity even if V_{IO} is the only supply voltage available. When pin RXD1/RXD2 goes LOW to signal a wake-up request, a transition to Normal mode will not be triggered until STBN1/STBN2 is forced HIGH.

7.1.3 Remote wake-up (via the CAN bus)

A dedicated wake-up sequence (specified in ISO 11898-2:2016) must be received to wake-up the TJA1048 from a low-power mode. This filtering is necessary to avoid spurious wake-up events due to a dominant clamped CAN bus or dominant phases caused by noise or spikes on the bus.

A valid wake-up pattern consists of:

- A dominant phase of at least $t_{wake(busdom)}$ followed by
- A recessive phase of at least $t_{wake(busrec)}$ followed by
- A dominant phase of at least $t_{wake(busdom)}$

The complete dominant-recessive-dominant pattern must be received within $t_{to(wake)bus}$ to be recognized as a valid wake-up pattern (see Figure 4). Pin RXD1/RXD2 will remain recessive until the wake-up event has been triggered.

After a wake-up sequence has been detected, the TJA1048 will remain in Standby mode with the bus signals reflected on RXD1/RXD2. Note that dominant or recessive phases lasting less than $t_{ftr(wake)bus}$ will not be detected by the low-power differential receiver and will not be reflected on RXD1/RXD2 in Standby mode.

A wake-up event will not be registered if any of the following events occurs while a wake-up sequence is being transmitted:

- The TJA1048 switches to Normal mode
- The complete wake-up pattern was not received within $t_{to(wake)bus}$
- A V_{IO} undervoltage is detected ($V_{IO} < V_{uvd(VIO)}$; see Section 7.2.3)

If any of these events occurs while a wake-up sequence is being received, the internal wake-up logic will be reset and the complete wake-up sequence will have to be re-transmitted to trigger a wake-up event.

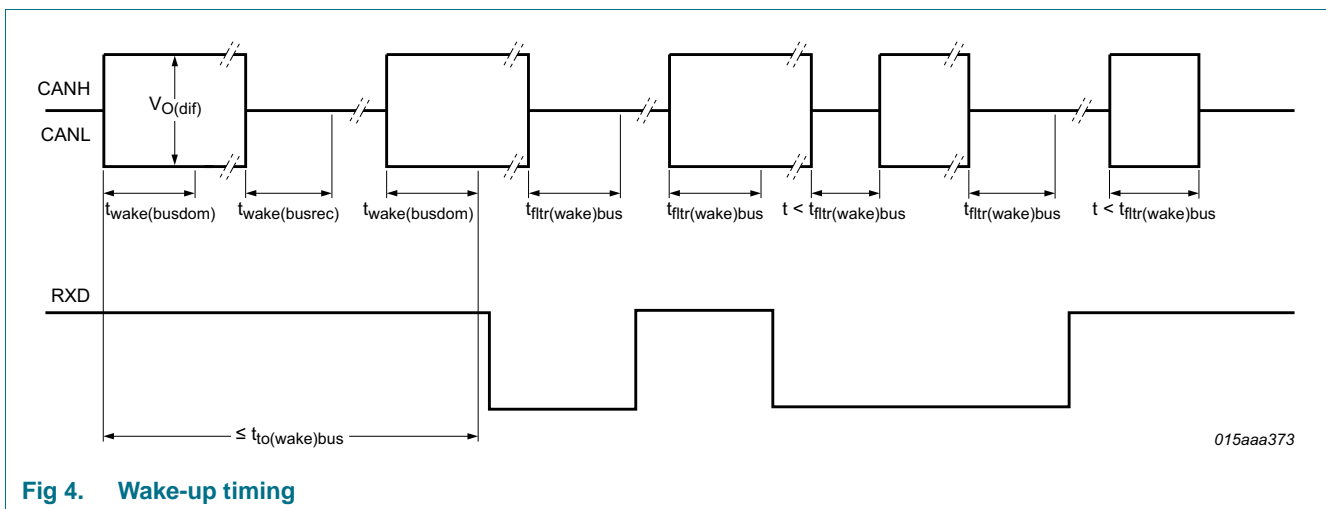

Fig 4. Wake-up timing

7.2 Fail-safe features

7.2.1 TXD dominant time-out function

A 'TXD dominant time-out' timer is started when pin TXD1/TXD2 is set LOW. If the LOW state on this pin persists for longer than $t_{to(dom)TXD}$, the transmitter is disabled, releasing the bus lines to recessive state. This function prevents a hardware and/or software application failure from driving the bus lines to a permanent dominant state (blocking all network communications). The TXD dominant time-out timer is reset when pin TXD1/TXD2 is set HIGH. The TXD dominant time-out time also defines the minimum possible bit rate of 40 kbit/s. The TJA1048 has two TXD dominant time-out timers that operate independently of each other.

7.2.2 Internal biasing of TXD1, TXD2, STBN1 and STBN2 input pins

Pins TXD1 and TXD2 have internal pull-ups to V_{IO} and pins STBN1 and STBN2 have internal pull-downs to GNDA and GNDB. This ensures a safe, defined state if any of these pins is left floating. Pins GNDA and GNDB must be connected together in the application.

Pull-up/pull-down currents flow in these pins in all states. Pins TXD1 and TXD2 should be held HIGH in Standby mode to minimize the supply current; pins STBN1 and STBN2 should be held LOW.

7.2.3 Undervoltage detection on pins V_{CC} and V_{IO}

Should V_{CC} drop below the V_{CC} undervoltage detection level, $V_{uvd(VCC)}$, both transceivers will switch to Standby mode. The logic state of pins STBN1 and STBN2 will be ignored until V_{CC} has recovered.

Should V_{IO} drop below the V_{IO} undervoltage detection level, $V_{uvd(VIO)}$, the transceivers will switch off and disengage from the bus (zero load) until V_{IO} has recovered.

7.2.4 Overtemperature protection

The output drivers are protected against overtemperature conditions. If the virtual junction temperature exceeds the shutdown junction temperature, $T_{j(sd)}$, both output drivers will be disabled. When the virtual junction temperature drops below $T_{j(sd)}$ again, the output drivers will recover independently once TXD1/TXD2 has been reset to HIGH. Including the TXD1/TXD2 condition prevents output driver oscillation due to small variations in temperature.

7.3 V_{IO} supply pin

Pin V_{IO} should be connected to the microcontroller supply voltage (see [Figure 7](#)). This will adjust the signal levels of pins TXD1, TXD2, RXD1, RXD2, STBN1 and STBN2 to the I/O levels of the microcontroller. Pin V_{IO} also provides the internal supply voltage for the transceiver's low-power differential receiver. For applications running in low-power mode, this allows the bus lines to be monitored for activity even if there is no supply voltage on pin V_{CC} .

8. Limiting values

Table 5. Limiting values

In accordance with the Absolute Maximum Rating System (IEC 60134). All voltages are referenced to GND.

| Symbol | Parameter | Conditions | Min | Max | Unit |
|--------------------------|---------------------------------------|---|------|------|------|
| V _x | voltage on pin x ^[1] | on pins CANH1, CANL1, CANH2 and CANL2 | -58 | +58 | V |
| | | on any other pin | -0.3 | +7 | V |
| V _(CANH-CANL) | voltage between pin CANH and pin CANL | | -27 | +27 | V |
| V _{trt} | transient voltage | on pins CANH1, CANL1, CANH2 and CANL2 ^[2] | | | |
| | | pulse 1 | -100 | - | V |
| | | pulse 2a | - | 75 | V |
| | | pulse 3a | -150 | - | V |
| | | pulse 3b | - | 100 | V |
| V _{ESD} | electrostatic discharge voltage | IEC 61000-4-2 (150 pF, 330 Ω) ^[3] | | | |
| | | on pins CANH1, CANL1, CANH2 and CANL2 | -6 | +6 | kV |
| | | Human Body Model (HBM); 100 pF, 1.5 kΩ ^[4] | | | |
| | | on pins CANH1, CANL1, CANH2 and CANL2 | -6 | +6 | kV |
| | | at any other pin | -4 | +4 | kV |
| | | Machine Model (MM); 200 pF, 0.75 μH, 10 Ω ^[5] | | | |
| | | at any pin | -300 | +300 | V |
| | | Charged Device Model (CDM); field Induced charge; 4 pF ^[6] | | | |
| at corner pins | -750 | +750 | V | | |
| at any pin | -500 | +500 | V | | |
| T _{vj} | virtual junction temperature | ^[7] | -40 | +150 | °C |
| T _{stg} | storage temperature | | -55 | +150 | °C |

- [1] The device can sustain voltages up to the specified values over the product lifetime, provided applied voltages (including transients) never exceed these values.
- [2] According to IEC TS 62228 (2007), Section 4.2.4; parameters for standard pulses defined in ISO7637 part 2: 2004-06.
- [3] According to IEC TS 62228 (2007), Section 4.3; DIN EN 61000-4-2.
- [4] According to AEC-Q100-002.
- [5] According to AEC-Q100-003.
- [6] According to AEC-Q100-011 Rev-C1. The classification level is C4B.
- [7] In accordance with IEC 60747-1. An alternative definition of virtual junction temperature is: $T_{vj} = T_{amb} + P \times R_{th(vj-a)}$, where $R_{th(vj-a)}$ is a fixed value to be used for the calculation of T_{vj} . The rating for T_{vj} limits the allowable combinations of power dissipation (P) and ambient temperature (T_{amb}).

9. Thermal characteristics

Table 6. Thermal characteristics

Values determined for free convection conditions on a JESD51-7 board.

| Symbol | Parameter | Conditions | Value | Unit |
|-----------------------|---|------------|-------|------|
| R _{th(vj-a)} | thermal resistance from virtual junction to ambient | SO14 | 65 | K/W |
| | | HVSON14 | 42 | K/W |

10. Static characteristics

Table 7. Static characteristics

$T_{vj} = -40\text{ }^{\circ}\text{C}$ to $+150\text{ }^{\circ}\text{C}$; $V_{CC} = 4.5\text{ V}$ to 5.5 V ; $V_{IO} = 2.8\text{ V}$ to 5.5 V ; $R_L = 60\text{ }\Omega$ unless specified otherwise; all voltages are defined with respect to ground; positive currents flow into the device^[1].

| Symbol | Parameter | Conditions | Min | Typ | Max | Unit | | |
|---|---|---|--------------------|------|-----------------------|---------------|---------------|--|
| Supply; pin V_{CC} | | | | | | | | |
| V _{CC} | supply voltage | | 4.5 | - | 5.5 | V | | |
| I _{CC} | supply current | Standby mode; V _{TxD} ^[2] = V _{IO} | ^[3] | - | 0.5 | 5 | μA | |
| | | Normal mode | | | | | | |
| | | both channels recessive | | - | - | 20 | mA | |
| | | one channel dominant | | - | - | 80 | mA | |
| | | both channels dominant | | - | 90 | 140 | mA | |
| | | Normal mode; V _{TxD} = 0 V; -3 V < (V _{CANH} = V _{CANL}) < +18 V | | | | | | |
| | | one channel recessive; short-circuit on other channel | | - | 90 | 120 | mA | |
| one channel dominant; short-circuit on other channel | | - | 150 | 180 | mA | | | |
| short-circuit on both channels | | - | 160 | 220 | mA | | | |
| V _{uvd(VCC)} | undervoltage detection voltage on pin V _{CC} | | 3.5 | - | 4.5 | V | | |
| I/O level adapter supply; pin V_{IO} | | | | | | | | |
| V _{IO} | supply voltage on pin V _{IO} | | 2.8 | - | 5.5 | V | | |
| I _{IO} | supply current on pin V _{IO} | Standby mode; V _{TxD} = V _{IO} | ^[3] | - | 16.5 | 26 | μA | |
| | | Normal mode | | | | | | |
| | | both channels recessive | | - | - | 35 | μA | |
| | | one channel dominant | | - | - | 300 | μA | |
| both channels dominant | | - | - | 550 | μA | | | |
| V _{uvd(VIO)} | undervoltage detection voltage on pin V _{IO} | | 1.3 | 2.0 | 2.7 | V | | |
| Standby mode control input; pins STBN1 and STBN2 | | | | | | | | |
| V _{IH} | HIGH-level input voltage | | 0.7V _{IO} | - | V _{IO} + 0.3 | V | | |
| V _{IL} | LOW-level input voltage | | -0.3 | - | 0.3V _{IO} | V | | |
| I _{IH} | HIGH-level input current | V _{STBN} ^[4] = V _{IO} | 1 | - | 10 | μA | | |
| I _{IL} | LOW-level input current | V _{STBN} = 0 V | -1 | - | +1 | μA | | |
| CAN transmit data input; pins TXD1 and TXD2 | | | | | | | | |
| V _{IH} | HIGH-level input voltage | | 0.7V _{IO} | - | V _{IO} + 0.3 | V | | |
| V _{IL} | LOW-level input voltage | | -0.3 | - | 0.3V _{IO} | V | | |
| I _{IH} | HIGH-level input current | V _{TxD} ^[2] = V _{IO} | -5 | - | +5 | μA | | |
| I _{IL} | LOW-level input current | V _{TxD} = 0 V | -260 | -150 | -30 | μA | | |
| C _i | input capacitance | ^[5] | - | 5 | 10 | pF | | |
| CAN receive data output; pins RXD1 and RXD2 | | | | | | | | |
| I _{OH} | HIGH-level output current | V _{RxD} ^[6] = V _{IO} - 0.4 V; V _{IO} = V _{CC} | -9 | -3 | -1 | mA | | |
| I _{OL} | LOW-level output current | V _{RxD} = 0.4 V; bus dominant | 2 | 5 | 12 | mA | | |

Table 7. Static characteristics ...continued

$T_{vj} = -40\text{ }^{\circ}\text{C}$ to $+150\text{ }^{\circ}\text{C}$; $V_{CC} = 4.5\text{ V}$ to 5.5 V ; $V_{IO} = 2.8\text{ V}$ to 5.5 V ; $R_L = 60\text{ }\Omega$ unless specified otherwise; all voltages are defined with respect to ground; positive currents flow into the device^[1].

| Symbol | Parameter | Conditions | Min | Typ | Max | Unit |
|--|---|--|--------------|--------------|--------------|------|
| Bus lines; pins CANH1, CANL1, CANH2 and CANL2 | | | | | | |
| $V_{O(dom)}$ | dominant output voltage | $V_{TXD} = 0\text{ V}$; $t < t_{to(dom)TXD}$ | | | | |
| | | pin CANH1/CANH2; $R_L = 50\text{ }\Omega$ to $65\text{ }\Omega$ | 2.75 | 3.5 | 4.5 | V |
| | | pin CANL1/CANL2; $R_L = 50\text{ }\Omega$ to $65\text{ }\Omega$ | 0.5 | 1.5 | 2.25 | V |
| $V_{dom(TX)sym}$ | transmitter dominant voltage symmetry | $V_{dom(TX)sym} = V_{CC} - V_{CANH}^{[7]} - V_{CANL}^{[8]}$ | -300 | - | +300 | mV |
| V_{TXsym} | transmitter voltage symmetry | $V_{TXsym} = V_{CANH}^{[7]} + V_{CANL}^{[8]}$; $C_{SPLIT} = 4.7\text{ nF}$; $f_{TXD} = 250\text{ kHz}$, 1 MHz and 2.5 MHz ; $V_{CC} = 4.75\text{ V}$ to 5.25 V | 0.9 V_{CC} | - | 1.1 V_{CC} | V |
| $V_{O(dif)}$ | differential output voltage | dominant: Normal mode | | | | |
| | | $V_{TXD} = 0\text{ V}$; $t < t_{to(dom)TXD}$; $V_{CC} = 4.75\text{ V}$ to 5.25 V ; $R_L = 45\text{ }\Omega$ to $65\text{ }\Omega$ | 1.5 | - | 3 | V |
| | | $V_{TXD} = 0\text{ V}$; $t < t_{to(dom)TXD}$; $V_{CC} = 4.75\text{ V}$ to 5.25 V ; $R_L = 45\text{ }\Omega$ to $70\text{ }\Omega$ | 1.5 | - | 3.3 | V |
| | | $V_{TXD} = 0\text{ V}$; $t < t_{to(dom)TXD}$; $V_{CC} = 4.75\text{ V}$ to 5.25 V ; $R_L = 2240\text{ }\Omega$ | 1.5 | - | 5 | V |
| | | recessive | | | | |
| | | Normal mode: $V_{TXD} = V_{IO}$; no load | -50 | - | +50 | mV |
| | | Standby mode | -0.2 | - | +0.2 | V |
| $V_{O(rec)}$ | recessive output voltage | recessive; no load | | | | |
| | | Normal mode; $V_{TXD} = V_{IO}$ | 2 | 0.5 V_{CC} | 3 | V |
| | | Standby mode | -0.1 | - | +0.1 | V |
| $V_{th(RX)dif}$ | differential receiver threshold voltage | Normal mode; $-30\text{ V} \leq V_{CANL} \leq +30\text{ V}$; $-30\text{ V} \leq V_{CANH} \leq +30\text{ V}$ | 0.5 | 0.7 | 0.9 | V |
| | | Standby mode; $-12\text{ V} \leq V_{CANL} \leq +12\text{ V}$; $-12\text{ V} \leq V_{CANH} \leq +12\text{ V}$ | 0.4 | 0.7 | 1.15 | V |
| $V_{rec(RX)}$ | receiver recessive voltage | Normal mode; $-30\text{ V} \leq V_{CANL} \leq +30\text{ V}$; $-30\text{ V} \leq V_{CANH} \leq +30\text{ V}$ | -4 | - | 0.5 | V |
| | | Standby mode; $-12\text{ V} \leq V_{CANL} \leq +12\text{ V}$; $-12\text{ V} \leq V_{CANH} \leq +12\text{ V}$ | -4 | - | 0.4 | V |
| $V_{dom(RX)}$ | receiver dominant voltage | Normal mode; $-30\text{ V} \leq V_{CANL} \leq +30\text{ V}$; $-30\text{ V} \leq V_{CANH} \leq +30\text{ V}$ | 0.9 | - | 9.0 | V |
| | | Standby mode; $-12\text{ V} \leq V_{CANL} \leq +12\text{ V}$; $-12\text{ V} \leq V_{CANH} \leq +12\text{ V}$ | 1.15 | - | 9.0 | V |

Table 7. Static characteristics ...continued

$T_{vj} = -40\text{ }^{\circ}\text{C}$ to $+150\text{ }^{\circ}\text{C}$; $V_{CC} = 4.5\text{ V}$ to 5.5 V ; $V_{IO} = 2.8\text{ V}$ to 5.5 V ; $R_L = 60\text{ }\Omega$ unless specified otherwise; all voltages are defined with respect to ground; positive currents flow into the device^[1].

| Symbol | Parameter | Conditions | Min | Typ | Max | Unit |
|------------------------------|--|---|------|-----|-----|--------------------|
| $V_{hys(RX)dif}$ | differential receiver hysteresis voltage | Normal mode: $-30\text{ V} \leq V_{CANL} \leq +30\text{ V}$; $-30\text{ V} \leq V_{CANH} \leq +30\text{ V}$ | 50 | 120 | 200 | mV |
| $I_{O(sc)dom}$ | dominant short-circuit output current | $V_{TXD} = 0\text{ V}$; $t < t_{to(dom)TXD}$; $V_{CC} = 5\text{ V}$ pin CANH1/CANH2; $V_{CANH} = -15\text{ V}$ to $+40\text{ V}$ | -100 | -70 | -40 | mA |
| | | pin CANL1/CANL2; $V_{CANL} = -15\text{ V}$ to $+40\text{ V}$ | 40 | 70 | 100 | mA |
| $I_{O(sc)rec}$ | recessive short-circuit output current | Normal mode; $V_{TXD} = V_{IO}$; $V_{CANH} = V_{CANL} = -40\text{ V}$ to $+40\text{ V}$ | -5 | - | +5 | mA |
| I_L | leakage current | $V_{CC} = V_{IO} = 0\text{ V}$ or $V_{CC} = V_{IO} =$ shorted to ground via $47\text{ k}\Omega$; $V_{CANH} = V_{CANL} = 5\text{ V}$ | -5 | - | +5 | μA |
| R_i | input resistance | $-2\text{ V} \leq V_{CANL} \leq +7\text{ V}$; $-2\text{ V} \leq V_{CANH} \leq +7\text{ V}$ | 9 | 15 | 28 | $\text{k}\Omega$ |
| ΔR_i | input resistance deviation | $0\text{ V} \leq V_{CANL} \leq +5\text{ V}$; $0\text{ V} \leq V_{CANH} \leq +5\text{ V}$ | -1 | - | +1 | % |
| $R_{i(dif)}$ | differential input resistance | $-2\text{ V} \leq V_{CANL} \leq +7\text{ V}$; $-2\text{ V} \leq V_{CANH} \leq +7\text{ V}$ | 19 | 30 | 52 | $\text{k}\Omega$ |
| $C_{i(cm)}$ | common-mode input capacitance | [5] | - | - | 20 | pF |
| $C_{i(dif)}$ | differential input capacitance | [5] | - | - | 10 | pF |
| Temperature detection | | | | | | |
| $T_{j(sd)}$ | shutdown junction temperature | [5] | - | 190 | - | $^{\circ}\text{C}$ |

- [1] All parameters are guaranteed over the virtual junction temperature range by design. Factory testing uses correlated test conditions to cover the specified temperature and power supply voltage range.
- [2] TXD refers to the input signal on pin TXD1 or pin TXD2.
- [3] Total supply current ($I_{CC} + I_{IO}$) in Standby mode is typically $17\text{ }\mu\text{A}$, with a maximum value of $26\text{ }\mu\text{A}$.
- [4] STBN refers to the input signal on pin STBN1 or pin STBN2.
- [5] Not tested in production; guaranteed by design.
- [6] RXD refers to the output signal on pin RXD1 or pin RXD2.
- [7] CANH refers to the input/output signal on pin CANH1 or pin CANH2.
- [8] CANL refers to the input/output signal on pin CANL1 or pin CANL2.
- [9] The test circuit used to measure the bus output voltage symmetry (which includes CSPLIT) is shown in [Figure 9](#).

11. Dynamic characteristics

Table 8. Dynamic characteristics

$T_{vj} = -40\text{ }^{\circ}\text{C}$ to $+150\text{ }^{\circ}\text{C}$; $V_{CC} = 4.5\text{ V}$ to 5.5 V ; $V_{IO} = 2.8\text{ V}$ to 5.5 V ; $R_L = 60\text{ }\Omega$ unless specified otherwise; all voltages are defined with respect to ground; positive currents flow into the device^[1].

| Symbol | Parameter | Conditions | Min | Typ | Max | Unit | |
|--|--------------------------------------|--|-----|-----|-----|---------------|----|
| Transceiver timing; pins CANH1, CANH2, CANL1, CANL2, TXD1, TXD2, RXD1 and RXD2; see Figure 8 and Figure 5 | | | | | | | |
| $t_{d(\text{TXD-busdom})}$ | delay time from TXD to bus dominant | Normal mode | - | 65 | - | ns | |
| $t_{d(\text{TXD-busrec})}$ | delay time from TXD to bus recessive | Normal mode | - | 90 | - | ns | |
| $t_{d(\text{busdom-RXD})}$ | delay time from bus dominant to RXD | Normal mode | - | 60 | - | ns | |
| $t_{d(\text{busrec-RXD})}$ | delay time from bus recessive to RXD | Normal mode | - | 65 | - | ns | |
| $t_{d(\text{TXDL-RXDL})}$ | delay time from TXD LOW to RXD LOW | Normal mode | 60 | - | 250 | ns | |
| $t_{d(\text{TXDH-RXDH})}$ | delay time from TXD HIGH to RXD HIGH | Normal mode | 60 | - | 250 | ns | |
| $t_{\text{bit}(\text{bus})}$ | transmitted recessive bit width | $t_{\text{bit}(\text{TXD})} = 500\text{ ns}$ | [2] | 435 | - | 530 | ns |
| | | $t_{\text{bit}(\text{TXD})} = 200\text{ ns}$ | [2] | 155 | - | 210 | ns |
| $t_{\text{bit}(\text{RXD})}$ | bit time on pin RXD | $t_{\text{bit}(\text{TXD})} = 500\text{ ns}$ | [2] | 400 | - | 550 | ns |
| | | $t_{\text{bit}(\text{TXD})} = 200\text{ ns}$ | [2] | 120 | - | 220 | ns |
| Δt_{rec} | receiver timing symmetry | $t_{\text{bit}(\text{TXD})} = 500\text{ ns}$ | | -65 | - | +40 | ns |
| | | $t_{\text{bit}(\text{TXD})} = 200\text{ ns}$ | | -45 | - | +15 | ns |
| $t_{\text{to}(\text{dom})\text{TXD}}$ | TXD dominant time-out time | $V_{\text{TXD}} = 0\text{ V}$; Normal mode | [3] | 0.5 | 2 | 5 | ms |
| $t_{d(\text{stb-norm})}$ | standby to normal mode delay time | | 7 | 25 | 47 | μs | |
| $t_{\text{wake}(\text{busdom})}$ | bus dominant wake-up time | Standby mode | 0.5 | - | 5 | μs | |
| $t_{\text{wake}(\text{busrec})}$ | bus recessive wake-up time | Standby mode | 0.5 | - | 5 | μs | |
| $t_{\text{to}(\text{wake})\text{bus}}$ | bus wake-up time-out time | | 0.5 | 2 | 5 | ms | |
| $t_{\text{ftr}(\text{wake})\text{bus}}$ | bus wake-up filter time | Standby mode | 0.5 | 1.5 | 5 | μs | |

[1] All parameters are guaranteed over the virtual junction temperature range by design. Factory testing uses correlated test conditions to cover the specified temperature and power supply voltage range.

[2] See Figure 6.

[3] Minimum value of 0.8 ms required according to SAE J2284; 0.3 ms is allowed according to ISO11898-2:2016 for legacy devices.

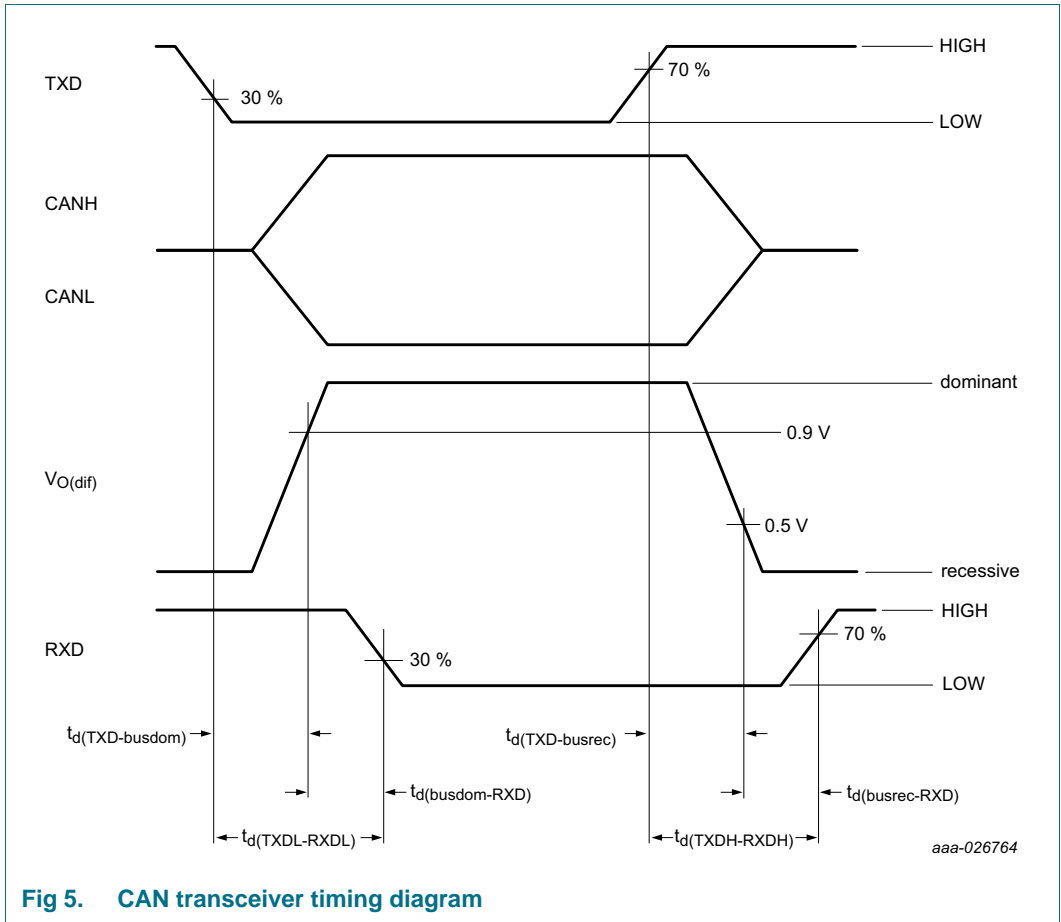

Fig 5. CAN transceiver timing diagram

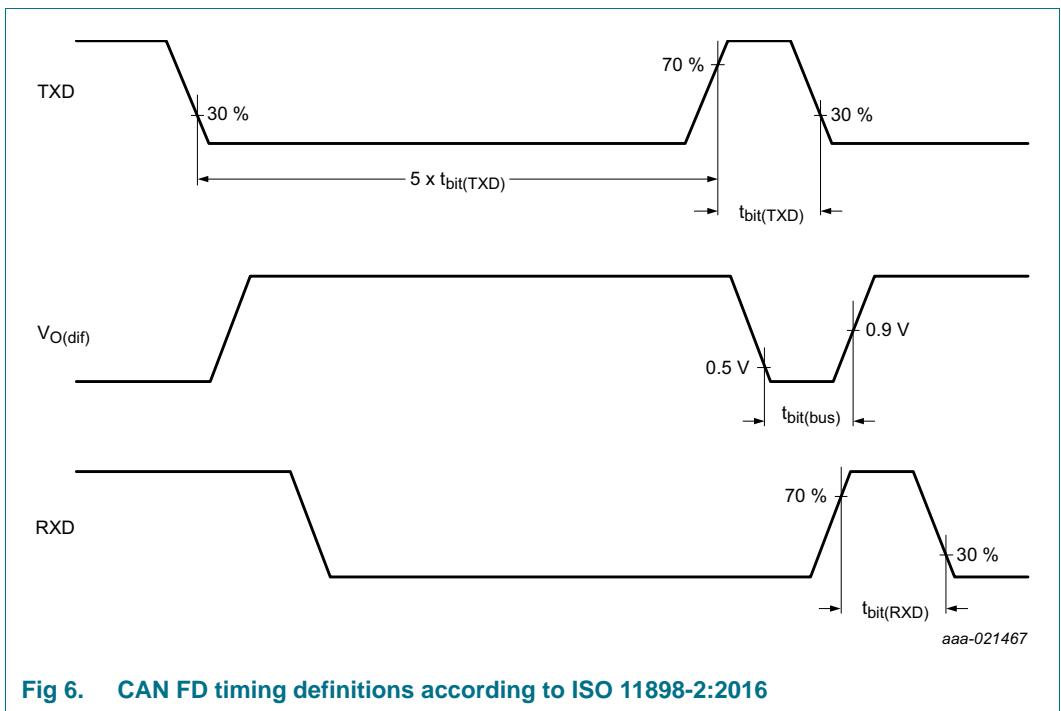

Fig 6. CAN FD timing definitions according to ISO 11898-2:2016

13. Test information

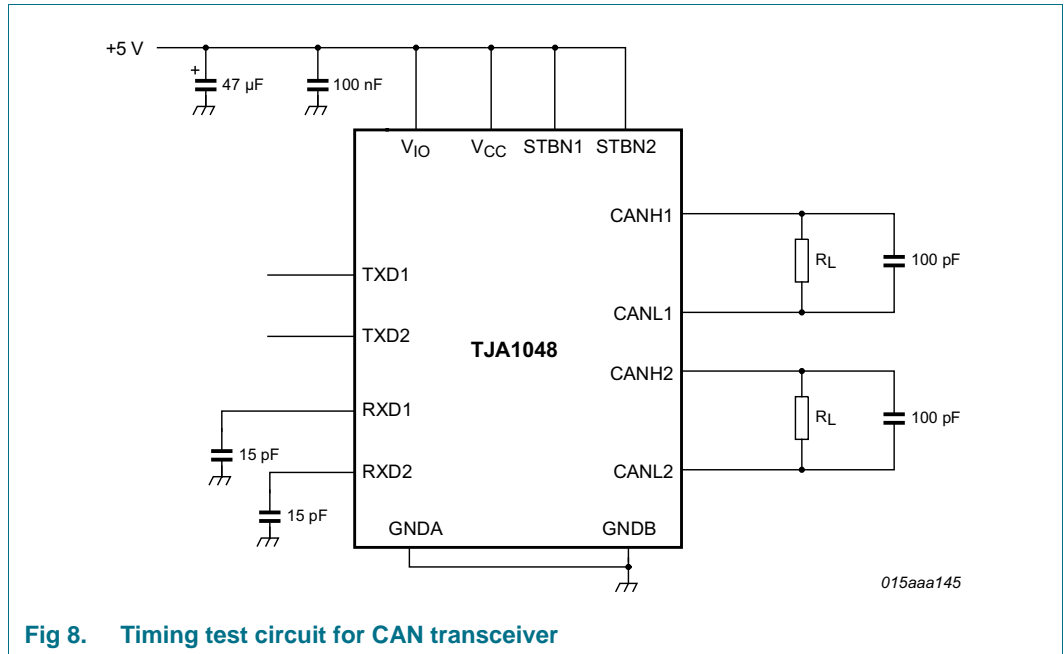

Fig 8. Timing test circuit for CAN transceiver

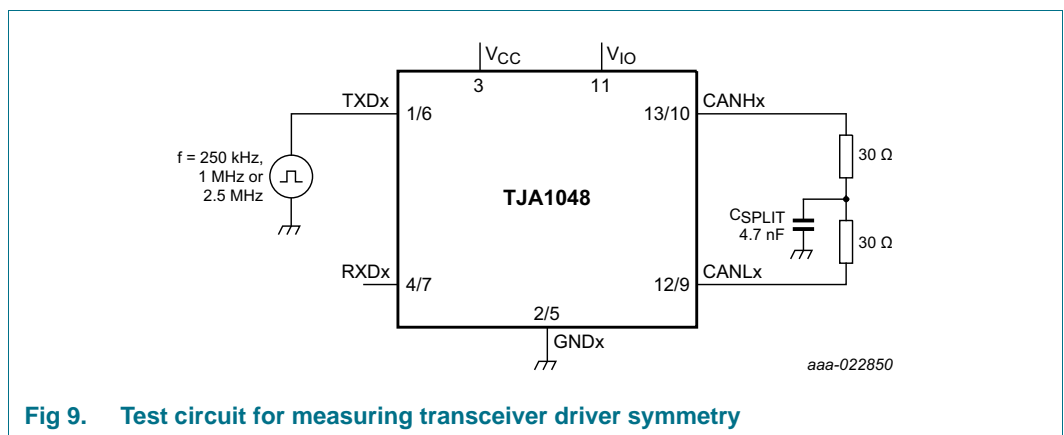

Fig 9. Test circuit for measuring transceiver driver symmetry

13.1 Quality information

This product has been qualified in accordance with the Automotive Electronics Council (AEC) standard Q100 Rev-G - *Failure mechanism based stress test qualification for integrated circuits*, and is suitable for use in automotive applications.

14. Package outline

SO14: plastic small outline package; 14 leads; body width 3.9 mm

SOT108-1



Fig 10. Package outline SOT108 (SO14)

HVSON14: plastic, thermal enhanced very thin small outline package; no leads; 14 terminals; body 3 x 4.5 x 0.85 mm

SOT1086-2

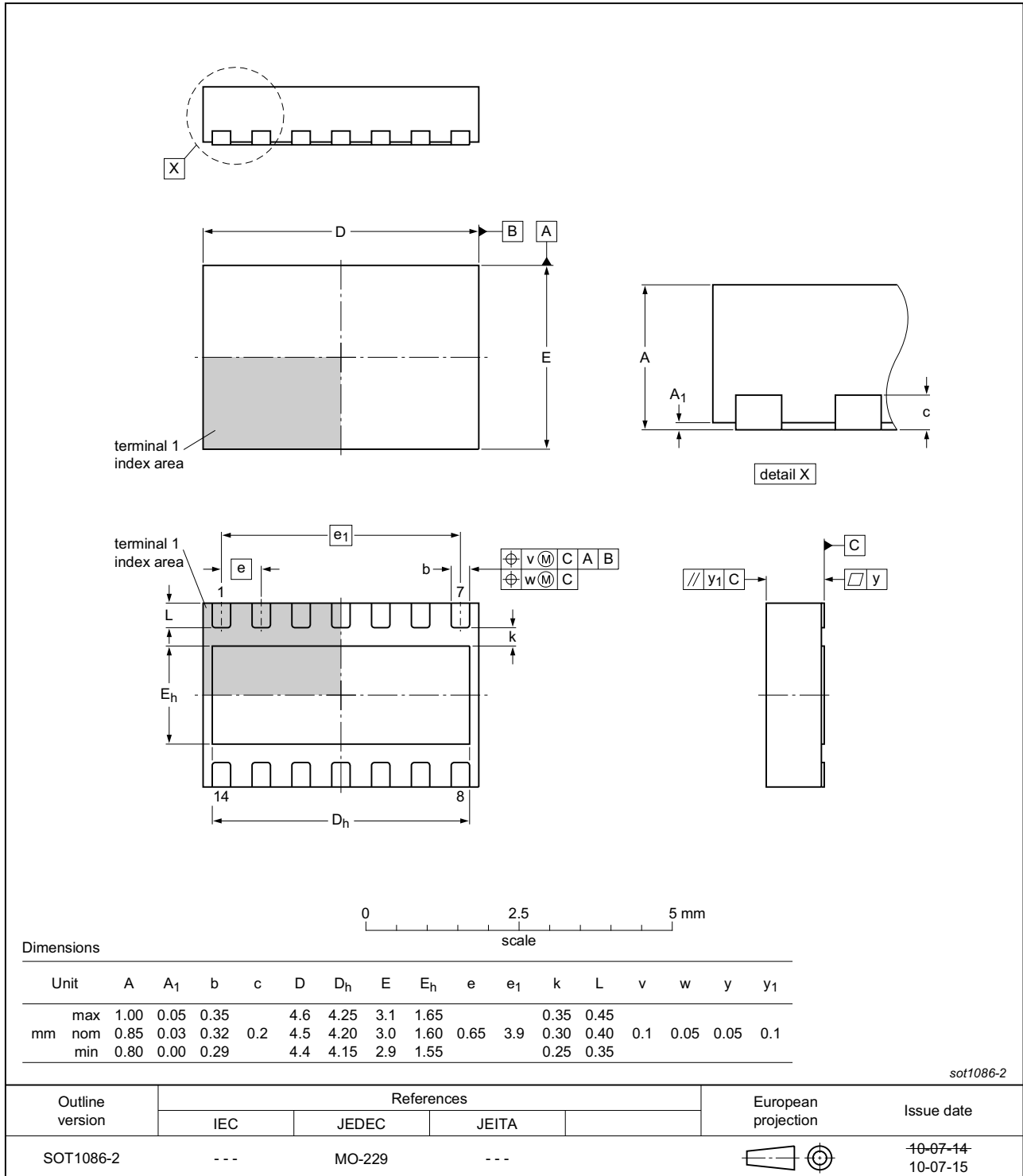

Fig 11. Package outline SOT1086 (HVSON14)

15. Handling information

All input and output pins are protected against ElectroStatic Discharge (ESD) under normal handling. When handling ensure that the appropriate precautions are taken as described in *JESD625-A* or equivalent standards.

16. Soldering of SMD packages

This text provides a very brief insight into a complex technology. A more in-depth account of soldering ICs can be found in Application Note *AN10365 "Surface mount reflow soldering description"*.

16.1 Introduction to soldering

Soldering is one of the most common methods through which packages are attached to Printed Circuit Boards (PCBs), to form electrical circuits. The soldered joint provides both the mechanical and the electrical connection. There is no single soldering method that is ideal for all IC packages. Wave soldering is often preferred when through-hole and Surface Mount Devices (SMDs) are mixed on one printed wiring board; however, it is not suitable for fine pitch SMDs. Reflow soldering is ideal for the small pitches and high densities that come with increased miniaturization.

16.2 Wave and reflow soldering

Wave soldering is a joining technology in which the joints are made by solder coming from a standing wave of liquid solder. The wave soldering process is suitable for the following:

- Through-hole components
- Leaded or leadless SMDs, which are glued to the surface of the printed circuit board

Not all SMDs can be wave soldered. Packages with solder balls, and some leadless packages which have solder lands underneath the body, cannot be wave soldered. Also, leaded SMDs with leads having a pitch smaller than ~0.6 mm cannot be wave soldered, due to an increased probability of bridging.

The reflow soldering process involves applying solder paste to a board, followed by component placement and exposure to a temperature profile. Leaded packages, packages with solder balls, and leadless packages are all reflow solderable.

Key characteristics in both wave and reflow soldering are:

- Board specifications, including the board finish, solder masks and vias
- Package footprints, including solder thieves and orientation
- The moisture sensitivity level of the packages
- Package placement
- Inspection and repair
- Lead-free soldering versus SnPb soldering

16.3 Wave soldering

Key characteristics in wave soldering are:

- Process issues, such as application of adhesive and flux, clinching of leads, board transport, the solder wave parameters, and the time during which components are exposed to the wave
- Solder bath specifications, including temperature and impurities

16.4 Reflow soldering

Key characteristics in reflow soldering are:

- Lead-free versus SnPb soldering; note that a lead-free reflow process usually leads to higher minimum peak temperatures (see [Figure 12](#)) than a SnPb process, thus reducing the process window
- Solder paste printing issues including smearing, release, and adjusting the process window for a mix of large and small components on one board
- Reflow temperature profile; this profile includes preheat, reflow (in which the board is heated to the peak temperature) and cooling down. It is imperative that the peak temperature is high enough for the solder to make reliable solder joints (a solder paste characteristic). In addition, the peak temperature must be low enough that the packages and/or boards are not damaged. The peak temperature of the package depends on package thickness and volume and is classified in accordance with [Table 9](#) and [10](#)

Table 9. SnPb eutectic process (from J-STD-020D)

| Package thickness (mm) | Package reflow temperature (°C) | |
|------------------------|---------------------------------|-------|
| | Volume (mm ³) | |
| | < 350 | ≥ 350 |
| < 2.5 | 235 | 220 |
| ≥ 2.5 | 220 | 220 |

Table 10. Lead-free process (from J-STD-020D)

| Package thickness (mm) | Package reflow temperature (°C) | | |
|------------------------|---------------------------------|-------------|--------|
| | Volume (mm ³) | | |
| | < 350 | 350 to 2000 | > 2000 |
| < 1.6 | 260 | 260 | 260 |
| 1.6 to 2.5 | 260 | 250 | 245 |
| > 2.5 | 250 | 245 | 245 |

Moisture sensitivity precautions, as indicated on the packing, must be respected at all times.

Studies have shown that small packages reach higher temperatures during reflow soldering, see [Figure 12](#).

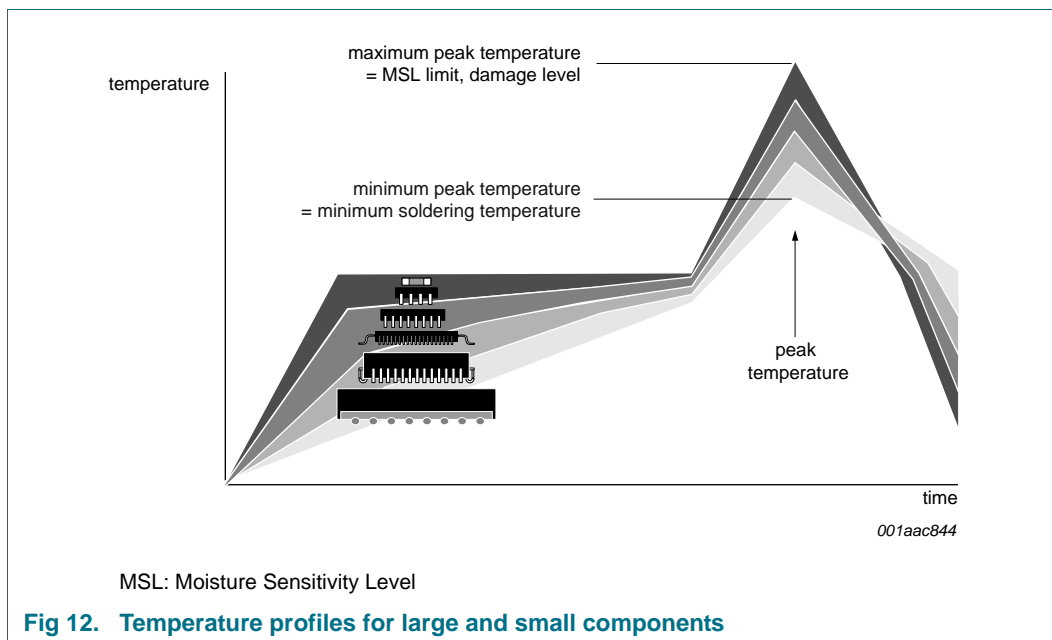

For further information on temperature profiles, refer to Application Note *AN10365* “*Surface mount reflow soldering description*”.

17. Soldering of HVSON packages

[Section 17](#) contains a brief introduction to the techniques most commonly used to solder Surface Mounted Devices (SMD). A more detailed discussion on soldering HVSON leadless package ICs can be found in the following application notes:

- *AN10365* “*Surface mount reflow soldering description*”
- *AN10366* “*HVQFN application information*” [Section 16](#)

18. Appendix: ISO 11898-2:2016 parameter cross-reference list

Table 11. ISO 11898-2:2016 to NXP data sheet parameter conversion

| ISO 11898-2:2016 | | NXP data sheet | |
|--|------------------------------|--------------------|---|
| Parameter | Notation | Symbol | Parameter |
| HS-PMA dominant output characteristics | | | |
| Single ended voltage on CAN_H | V_{CAN_H} | $V_{O(dom)}$ | dominant output voltage |
| Single ended voltage on CAN_L | V_{CAN_L} | | |
| Differential voltage on normal bus load | V_{Diff} | $V_{O(dif)}$ | differential output voltage |
| Differential voltage on effective resistance during arbitration | | | |
| Optional: Differential voltage on extended bus load range | | | |
| HS-PMA driver symmetry | | | |
| Driver symmetry | V_{SYM} | V_{TXsym} | transmitter voltage symmetry |
| Maximum HS-PMA driver output current | | | |
| Absolute current on CAN_H | I_{CAN_H} | $I_{O(sc)dom}$ | dominant short-circuit output current |
| Absolute current on CAN_L | I_{CAN_L} | | |
| HS-PMA recessive output characteristics, bus biasing active/inactive | | | |
| Single ended output voltage on CAN_H | V_{CAN_H} | $V_{O(rec)}$ | recessive output voltage |
| Single ended output voltage on CAN_L | V_{CAN_L} | | |
| Differential output voltage | V_{Diff} | $V_{O(dif)}$ | differential output voltage |
| Optional HS-PMA transmit dominant timeout | | | |
| Transmit dominant timeout, long | t_{dom} | $t_{to(dom)TXD}$ | TXD dominant time-out time |
| Transmit dominant timeout, short | | | |
| HS-PMA static receiver input characteristics, bus biasing active/inactive | | | |
| Recessive state differential input voltage range | V_{Diff} | $V_{th(RX)dif}$ | differential receiver threshold voltage |
| Dominant state differential input voltage range | | $V_{rec(RX)}$ | receiver recessive voltage |
| | | $V_{dom(RX)}$ | receiver dominant voltage |
| HS-PMA receiver input resistance (matching) | | | |
| Differential internal resistance | R_{Diff} | $R_{i(dif)}$ | differential input resistance |
| Single ended internal resistance | R_{CAN_H} R_{CAN_L} | R_i | input resistance |
| Matching of internal resistance | MR | ΔR_i | input resistance deviation |
| HS-PMA implementation loop delay requirement | | | |
| Loop delay | t_{Loop} | $t_{d(TXDH-RXDH)}$ | delay time from TXD HIGH to RXD HIGH |
| | | $t_{d(TXDL-RXDL)}$ | delay time from TXD LOW to RXD LOW |
| Optional HS-PMA implementation data signal timing requirements for use with bit rates above 1 Mbit/s up to 2 Mbit/s and above 2 Mbit/s up to 5 Mbit/s | | | |
| Transmitted recessive bit width @ 2 Mbit/s / @ 5 Mbit/s, intended | $t_{Bit(Bus)}$ | $t_{bit(bus)}$ | transmitted recessive bit width |
| Received recessive bit width @ 2 Mbit/s / @ 5 Mbit/s | $t_{Bit(RXD)}$ | $t_{bit(RXD)}$ | bit time on pin RXD |
| Receiver timing symmetry @ 2 Mbit/s / @ 5 Mbit/s | Δt_{Rec} | Δt_{rec} | receiver timing symmetry |

Table 11. ISO 11898-2:2016 to NXP data sheet parameter conversion

| ISO 11898-2:2016 | | NXP data sheet | |
|--|--|--|---------------------------------------|
| Parameter | Notation | Symbol | Parameter |
| HS-PMA maximum ratings of V_{CAN_H}, V_{CAN_L} and V_{Diff} | | | |
| Maximum rating V _{Diff} | V _{Diff} | V _(CANH-CANL) | voltage between pin CANH and pin CANL |
| General maximum rating V _{CAN_H} and V _{CAN_L} | V _{CAN_H} | V _x | voltage on pin x |
| Optional: Extended maximum rating V _{CAN_H} and V _{CAN_L} | V _{CAN_L} | | |
| HS-PMA maximum leakage currents on CAN_H and CAN_L, unpowered | | | |
| Leakage current on CAN_H, CAN_L | I _{CAN_H} I _{CAN_L} | I _L | leakage current |
| HS-PMA bus biasing control timings | | | |
| CAN activity filter time, long | t _{Filter} | t _{wake(busdom)} ^[1] | bus dominant wake-up time |
| CAN activity filter time, short | | t _{wake(busrec)} ^[1] | bus recessive wake-up time |
| Wake-up timeout, short | t _{Wake} | t _{to(wake)bus} | bus wake-up time-out time |
| Wake-up timeout, long | | | |
| Timeout for bus inactivity | t _{Silence} | t _{to(silence)} | bus silence time-out time |
| Bus Bias reaction time | t _{Bias} | t _{d(busact-bias)} | delay time from bus active to bias |

[1] t_{filtr(wake)bus} - bus wake-up filter time, in devices with basic wake-up functionality

19. Revision history

Table 12. Revision history

| Document ID | Release date | Data sheet status | Change notice | Supersedes |
|----------------|---|--------------------|---------------|-------------|
| TJA1048 v.6 | 20180319 | Product data sheet | - | TJA1048 v.5 |
| Modifications: | <ul style="list-style-type: none"> • Updated to comply with ISO 11898-2:2016 and SAE J22884-1 through SAE J2284-5 specifications: <ul style="list-style-type: none"> – Section 1: text amended (2nd last paragraph) – Section 2.1: text amended (2nd entry) – Table 7: values/conditions changed for parameters I_{CC}, V_{TXsym}, $V_{O(dif)}$, $V_{O(dom)}$, $V_{O(rec)}$, $V_{rec(RX)}$, $V_{dom(RX)}$, $I_{O(sc)dom}$, I_{OH} for pins RXDx; measurement conditions added to parameters R_i, ΔR_i and $R_{i(dif)}$ – Table 7: additional measurements taken at $f_{TXD} = 1$ MHz and 2.5 MHz for parameter V_{TXsym}; see Figure 9 – Table 8: Table note 3 added – Figure 6: title changed • Amended Figure 5, Figure 7 and Figure 9 | | | |
| TJA1048 v.5 | 20160523 | Product data sheet | - | TJA1048 v.4 |
| TJA1048 v.4 | 20150115 | Product data sheet | - | TJA1048 v.3 |
| TJA1048 v.3 | 20130424 | Product data sheet | - | TJA1048 v.2 |
| TJA1048 v.2 | 20110325 | Product data sheet | - | TJA1048 v.1 |
| TJA1048 v.1 | 20101103 | Product data sheet | - | - |

20. Legal information

20.1 Data sheet status

| Document status ^{[1][2]} | Product status ^[3] | Definition |
|-----------------------------------|-------------------------------|---|
| Objective [short] data sheet | Development | This document contains data from the objective specification for product development. |
| Preliminary [short] data sheet | Qualification | This document contains data from the preliminary specification. |
| Product [short] data sheet | Production | This document contains the product specification. |

[1] Please consult the most recently issued document before initiating or completing a design.

[2] The term 'short data sheet' is explained in section "Definitions".

[3] The product status of device(s) described in this document may have changed since this document was published and may differ in case of multiple devices. The latest product status information is available on the Internet at URL <http://www.nxp.com>.

20.2 Definitions

Draft — The document is a draft version only. The content is still under internal review and subject to formal approval, which may result in modifications or additions. NXP Semiconductors does not give any representations or warranties as to the accuracy or completeness of information included herein and shall have no liability for the consequences of use of such information.

Short data sheet — A short data sheet is an extract from a full data sheet with the same product type number(s) and title. A short data sheet is intended for quick reference only and should not be relied upon to contain detailed and full information. For detailed and full information see the relevant full data sheet, which is available on request via the local NXP Semiconductors sales office. In case of any inconsistency or conflict with the short data sheet, the full data sheet shall prevail.

Product specification — The information and data provided in a Product data sheet shall define the specification of the product as agreed between NXP Semiconductors and its customer, unless NXP Semiconductors and customer have explicitly agreed otherwise in writing. In no event however, shall an agreement be valid in which the NXP Semiconductors product is deemed to offer functions and qualities beyond those described in the Product data sheet.

20.3 Disclaimers

Limited warranty and liability — Information in this document is believed to be accurate and reliable. However, NXP Semiconductors does not give any representations or warranties, expressed or implied, as to the accuracy or completeness of such information and shall have no liability for the consequences of use of such information. NXP Semiconductors takes no responsibility for the content in this document if provided by an information source outside of NXP Semiconductors.

In no event shall NXP Semiconductors be liable for any indirect, incidental, punitive, special or consequential damages (including - without limitation - lost profits, lost savings, business interruption, costs related to the removal or replacement of any products or rework charges) whether or not such damages are based on tort (including negligence), warranty, breach of contract or any other legal theory.

Notwithstanding any damages that customer might incur for any reason whatsoever, NXP Semiconductors' aggregate and cumulative liability towards customer for the products described herein shall be limited in accordance with the *Terms and conditions of commercial sale* of NXP Semiconductors.

Right to make changes — NXP Semiconductors reserves the right to make changes to information published in this document, including without limitation specifications and product descriptions, at any time and without notice. This document supersedes and replaces all information supplied prior to the publication hereof.

Suitability for use in automotive applications — This NXP Semiconductors product has been qualified for use in automotive applications. Unless otherwise agreed in writing, the product is not designed, authorized or warranted to be suitable for use in life support, life-critical or safety-critical systems or equipment, nor in applications where failure or malfunction of an NXP Semiconductors product can reasonably be expected to result in personal injury, death or severe property or environmental damage. NXP Semiconductors and its suppliers accept no liability for inclusion and/or use of NXP Semiconductors products in such equipment or applications and therefore such inclusion and/or use is at the customer's own risk.

Applications — Applications that are described herein for any of these products are for illustrative purposes only. NXP Semiconductors makes no representation or warranty that such applications will be suitable for the specified use without further testing or modification.

Customers are responsible for the design and operation of their applications and products using NXP Semiconductors products, and NXP Semiconductors accepts no liability for any assistance with applications or customer product design. It is customer's sole responsibility to determine whether the NXP Semiconductors product is suitable and fit for the customer's applications and products planned, as well as for the planned application and use of customer's third party customer(s). Customers should provide appropriate design and operating safeguards to minimize the risks associated with their applications and products.

NXP Semiconductors does not accept any liability related to any default, damage, costs or problem which is based on any weakness or default in the customer's applications or products, or the application or use by customer's third party customer(s). Customer is responsible for doing all necessary testing for the customer's applications and products using NXP Semiconductors products in order to avoid a default of the applications and the products or of the application or use by customer's third party customer(s). NXP does not accept any liability in this respect.

Limiting values — Stress above one or more limiting values (as defined in the Absolute Maximum Ratings System of IEC 60134) will cause permanent damage to the device. Limiting values are stress ratings only and (proper) operation of the device at these or any other conditions above those given in the Recommended operating conditions section (if present) or the Characteristics sections of this document is not warranted. Constant or repeated exposure to limiting values will permanently and irreversibly affect the quality and reliability of the device.

Terms and conditions of commercial sale — NXP Semiconductors products are sold subject to the general terms and conditions of commercial sale, as published at <http://www.nxp.com/profile/terms>, unless otherwise agreed in a valid written individual agreement. In case an individual agreement is concluded only the terms and conditions of the respective agreement shall apply. NXP Semiconductors hereby expressly objects to applying the customer's general terms and conditions with regard to the purchase of NXP Semiconductors products by customer.

No offer to sell or license — Nothing in this document may be interpreted or construed as an offer to sell products that is open for acceptance or the grant, conveyance or implication of any license under any copyrights, patents or other industrial or intellectual property rights.

Export control — This document as well as the item(s) described herein may be subject to export control regulations. Export might require a prior authorization from competent authorities.

Quick reference data — The Quick reference data is an extract of the product data given in the Limiting values and Characteristics sections of this document, and as such is not complete, exhaustive or legally binding.

Translations — A non-English (translated) version of a document is for reference only. The English version shall prevail in case of any discrepancy between the translated and English versions.

20.4 Trademarks

Notice: All referenced brands, product names, service names and trademarks are the property of their respective owners.

21. Contact information

For more information, please visit: <http://www.nxp.com>

For sales office addresses, please send an email to: salesaddresses@nxp.com

22. Contents

| | | | | | |
|-----------|--|-----------|-----------|--------------------------------------|-----------|
| 1 | General description | 1 | 20.1 | Data sheet status | 25 |
| 2 | Features and benefits | 1 | 20.2 | Definitions | 25 |
| 2.1 | General | 1 | 20.3 | Disclaimers | 25 |
| 2.2 | Low-power management | 2 | 20.4 | Trademarks | 26 |
| 2.3 | Protection | 2 | 21 | Contact information | 26 |
| 3 | Quick reference data | 2 | 22 | Contents | 27 |
| 4 | Ordering information | 3 | | | |
| 5 | Block diagram | 4 | | | |
| 6 | Pinning information | 5 | | | |
| 6.1 | Pinning | 5 | | | |
| 6.2 | Pin description | 5 | | | |
| 7 | Functional description | 6 | | | |
| 7.1 | Operating modes | 6 | | | |
| 7.1.1 | Normal mode | 6 | | | |
| 7.1.2 | Standby mode | 6 | | | |
| 7.1.3 | Remote wake-up (via the CAN bus) | 6 | | | |
| 7.2 | Fail-safe features | 7 | | | |
| 7.2.1 | TXD dominant time-out function | 7 | | | |
| 7.2.2 | Internal biasing of TXD1, TXD2, STBN1 and STBN2 input pins | 8 | | | |
| 7.2.3 | Undervoltage detection on pins V_{CC} and V_{IO} | 8 | | | |
| 7.2.4 | Overtemperature protection | 8 | | | |
| 7.3 | V_{IO} supply pin | 8 | | | |
| 8 | Limiting values | 9 | | | |
| 9 | Thermal characteristics | 9 | | | |
| 10 | Static characteristics | 10 | | | |
| 11 | Dynamic characteristics | 13 | | | |
| 12 | Application information | 15 | | | |
| 12.1 | Application diagram | 15 | | | |
| 12.2 | Application hints | 15 | | | |
| 13 | Test information | 16 | | | |
| 13.1 | Quality information | 16 | | | |
| 14 | Package outline | 17 | | | |
| 15 | Handling information | 19 | | | |
| 16 | Soldering of SMD packages | 19 | | | |
| 16.1 | Introduction to soldering | 19 | | | |
| 16.2 | Wave and reflow soldering | 19 | | | |
| 16.3 | Wave soldering | 19 | | | |
| 16.4 | Reflow soldering | 20 | | | |
| 17 | Soldering of HVSON packages | 21 | | | |
| 18 | Appendix: ISO 11898-2:2016 parameter cross-reference list | 22 | | | |
| 19 | Revision history | 24 | | | |
| 20 | Legal information | 25 | | | |

Please be aware that important notices concerning this document and the product(s) described herein, have been included in section 'Legal information'.

© NXP Semiconductors N.V. 2018.

All rights reserved.

For more information, please visit: <http://www.nxp.com>

For sales office addresses, please send an email to: salesaddresses@nxp.com

Date of release: 19 March 2018

Document identifier: TJA1048



Компания «ЭлектроПласт» предлагает заключение долгосрочных отношений при поставках импортных электронных компонентов на взаимовыгодных условиях!

Наши преимущества:

- Оперативные поставки широкого спектра электронных компонентов отечественного и импортного производства напрямую от производителей и с крупнейших мировых складов;
- Поставка более 17-ти миллионов наименований электронных компонентов;
- Поставка сложных, дефицитных, либо снятых с производства позиций;
- Оперативные сроки поставки под заказ (от 5 рабочих дней);
- Экспресс доставка в любую точку России;
- Техническая поддержка проекта, помощь в подборе аналогов, поставка прототипов;
- Система менеджмента качества сертифицирована по Международному стандарту ISO 9001;
- Лицензия ФСБ на осуществление работ с использованием сведений, составляющих государственную тайну;
- Поставка специализированных компонентов (Xilinx, Altera, Analog Devices, Intersil, Interpoint, Microsemi, Aeroflex, Peregrine, Syfer, Eurofarad, Texas Instrument, Miteq, Cobham, E2V, MA-COM, Hittite, Mini-Circuits, General Dynamics и др.);

Помимо этого, одним из направлений компании «ЭлектроПласт» является направление «Источники питания». Мы предлагаем Вам помощь Конструкторского отдела:

- Подбор оптимального решения, техническое обоснование при выборе компонента;
- Подбор аналогов;
- Консультации по применению компонента;
- Поставка образцов и прототипов;
- Техническая поддержка проекта;
- Защита от снятия компонента с производства.



Как с нами связаться

Телефон: 8 (812) 309 58 32 (многоканальный)

Факс: 8 (812) 320-02-42

Электронная почта: org@eplast1.ru

Адрес: 198099, г. Санкт-Петербург, ул. Калинина, дом 2, корпус 4, литера А.