

Single-Turn Precision Potentiometer

Model 6670 Series



Features:

- 2" diameter
- Conductive plastic technology



Models Available

6671	1/4" Shaft, 3/8" Bushing
6673	1/4" Shaft, Servo

Electrical

Resistance Range	1K to 300K Ohms
Standard Resistance Tolerance	±10%
Minimum Practical Resistance Tolerance	±3%
Independent Linearity ²	±0.25%
Minimum Practical Independent Linearity	±0.1%
Input Voltage	400 VDC maximum, not to exceed power rating
Power Rating	3.5 Watts at 70°C, derating to 0 at 125°C
Dielectric Strength	1,000 V rms
Insulation Resistance	1,000 Megohms minimum
Output smoothness	0.1% maximum
Actual Electrical Travel	350° nominal
Electrical Continuity Travel	354° minimum
End Voltage	maximum 0.5% of input voltage
Tap Tolerance	maximum 0.5% of input voltage
Resolution	essentially infinite
Temperature Coefficient of Resistance ³	-400 ppm/°C typical
Temperature Coefficient of Output Voltage ⁴	±10 ppm/°C typical

Mechanical

Total Mechanical Travel	360° continuous
Number of Gangs	4 maximum
Weight	4.0 oz. single gang nominal, 1.5 oz. each added gang
Shaft Runout	maximum T.I.R. 0.001"
Pilot Diameter Runout	maximum T.I.R. 0.0015"
Lateral Runout	maximum T.I.R. 0.005"
Shaft Radial Play	maximum 0.002"
Start/Run Torque	maximum 1.5 / 1.0 oz.-in. per gang, ES option adds 0.5 oz.-in.

¹ Specifications subject to change without notice.

² Linearity is measured between 1% and 99% of input voltage.

³ Special TCR available to ±100 ppm/°C.

⁴ Measured with 10 VDC CW to CCW and slider at 50% of electrical travel.

General Note

TT Electronics reserves the right to make changes in product specification without notice or liability. All information is subject to TT Electronics' own data and is considered accurate at time of going to print.

© TT electronics plc

TT Electronics | BI Technologies
413 Rood RD, Suite 7
Calxico, CA 92231
Ph: +1 714 447 2345
www.ttelectronics.com/bi-technologies

Single-Turn Precision Potentiometer

Model 5311



Environmental

Operating Temperature Range	-40°C to +125°C dynamic, -65°C to +125°C static
Temperature Cycling	5 cycles, -65°C to +125°C, maximum 10% ΔR
Shock	6 ms Saw-tooth, 100 G's, 0.1 ms maximum discontinuity
Vibration	15 G's, 10 to 2,000 Hz, maximum 2% ΔR, 0.1 ms maximum discontinuity
Moisture Resistance	ten 24 hour cycles, maximum 10% ΔR
High Temperature Exposure	1,000 hours at 125°C, maximum 0.5% ΔR
Rotational Life	25 million shaft revolutions
Rotational Load Life	5 million shaft revolutions plus 900 hours at 3.5 Watts & 70°C, maximum 10% ΔR
Ingress Protection Rating (IP Code)	IP50, IP66 available as option for 6671 (feature code ES)

Ordering Information

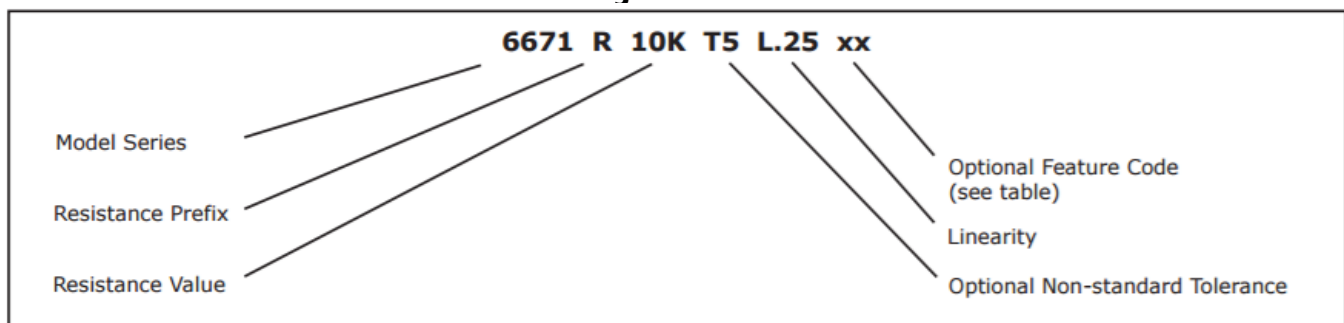

FEATURE CODES

Center Tap	CT
Linearity Tape	LT
Flatted Shaft	FS
Slotted Shaft	SS
Rear Shaft Extension	RS
Shaft Lock, 6671 only	SL
Additional Gangs	2G, 3G, or 4G
Seal (IP66), 6671 only	ES

When multiple feature codes are used the P/N shall be in the same sequence as listed in this table (top to bottom).

CIRCUIT DIAGRAM



STANDARD RESISTANCE VALUES

1K	2K	5K	10K	20K	50K
----	----	----	-----	-----	-----

General Note
 TT Electronics reserves the right to make changes in product specification without notice or liability. All information is subject to TT Electronics' own data and is considered accurate at time of going to print.

TT Electronics | BI Technologies
 413 Rood RD, Suite 7
 Calexico, CA 92231
 Ph: +1 714 447 2345
www.ttelectronics.com/bi-technologies

Single-Turn Precision Potentiometer

Model 5311



Model 6671 Bushing Mount



Dim. "L"	Dim. "RS"	No. of Gangs
$\frac{.905 \pm 0.020}{22.9 \pm 0.51}$	$\frac{1.405}{35.69}$	1
$\frac{1.467 \pm 0.22}{37.26 \pm 0.56}$	$\frac{1.967}{49.96}$	2
$\frac{2.029 \pm 0.024}{51.54 \pm 0.61}$	$\frac{2.529}{64.24}$	3
$\frac{2.591 \pm 0.026}{65.81 \pm 0.66}$	$\frac{3.091}{78.51}$	4

Model 6673 Servo Mount

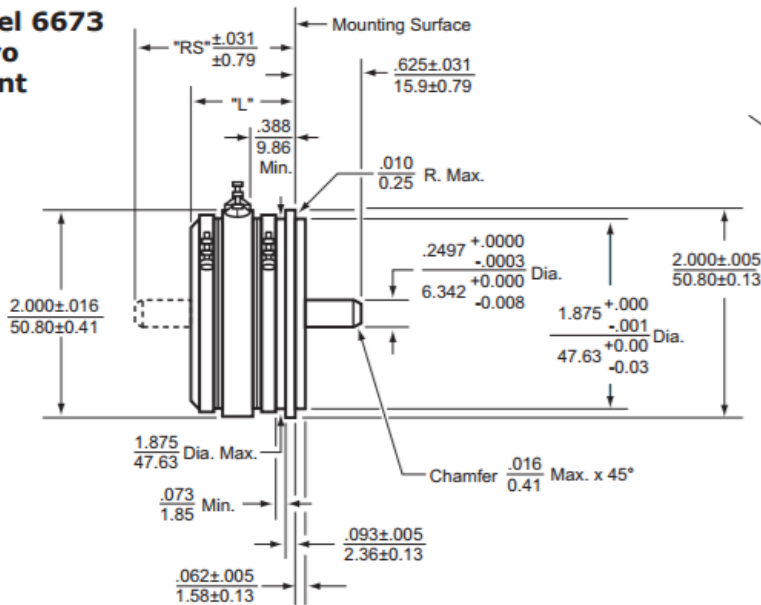

Dim. "L"	Dim. "RS"	No. of Gangs
$\frac{1.020 \pm 0.015}{22.9 \pm 0.51}$	$\frac{1.405}{35.69}$	1
$\frac{1.467 \pm 0.22}{37.26 \pm 0.56}$	$\frac{1.967}{49.96}$	2
$\frac{2.029 \pm 0.024}{51.54 \pm 0.61}$	$\frac{2.529}{64.24}$	3
$\frac{2.591 \pm 0.026}{65.81 \pm 0.66}$	$\frac{3.091}{78.51}$	4

General Note

TT Electronics reserves the right to make changes in product specification without notice or liability. All information is subject to TT Electronics' own data and is considered accurate at time of going to print.

© TT electronics plc

TT Electronics | BI Technologies
413 Rood RD, Suite 7
Calxico, CA 92231
Ph: +1 714 447 2345
www.ttelectronics.com/bi-technologies



Компания «ЭлектроПласт» предлагает заключение долгосрочных отношений при поставках импортных электронных компонентов на взаимовыгодных условиях!

Наши преимущества:

- Оперативные поставки широкого спектра электронных компонентов отечественного и импортного производства напрямую от производителей и с крупнейших мировых складов;
- Поставка более 17-ти миллионов наименований электронных компонентов;
- Поставка сложных, дефицитных, либо снятых с производства позиций;
- Оперативные сроки поставки под заказ (от 5 рабочих дней);
- Экспресс доставка в любую точку России;
- Техническая поддержка проекта, помощь в подборе аналогов, поставка прототипов;
- Система менеджмента качества сертифицирована по Международному стандарту ISO 9001;
- Лицензия ФСБ на осуществление работ с использованием сведений, составляющих государственную тайну;
- Поставка специализированных компонентов (Xilinx, Altera, Analog Devices, Intersil, Interpoint, Microsemi, Aeroflex, Peregrine, Syfer, Eurofarad, Texas Instrument, Miteq, Cobham, E2V, MA-COM, Hittite, Mini-Circuits, General Dynamics и др.);

Помимо этого, одним из направлений компании «ЭлектроПласт» является направление «Источники питания». Мы предлагаем Вам помощь Конструкторского отдела:

- Подбор оптимального решения, техническое обоснование при выборе компонента;
- Подбор аналогов;
- Консультации по применению компонента;
- Поставка образцов и прототипов;
- Техническая поддержка проекта;
- Защита от снятия компонента с производства.



Как с нами связаться

Телефон: 8 (812) 309 58 32 (многоканальный)

Факс: 8 (812) 320-02-42

Электронная почта: org@eplast1.ru

Адрес: 198099, г. Санкт-Петербург, ул. Калинина, дом 2, корпус 4, литера А.