

SPECIFICATION

- Part No. : AP.10F.07.0039B
- Product Name : 2 Stage 25dB 10mm Active GPS/GALILEO
Ceramic Patch Antenna 39mm 0.81 Micro Coax
with IPEX MHFI (U.FL compatible)
with Front End SAW Filter
- Feature : Small form factor GPS active patch
10mm*10mm*4mm,
Wide Voltage 1.8V~5.5V
25dB LNA
High performance
Ultra Low Power Consumption
RoHS Compliant



1. Introduction

The AP.10F active GPS patch antenna is the smallest GPS/GALILEO high performance antenna currently available in the world. It uses an extremely sensitive high dielectric constant powder formulation and tight process control and patented circular polarized side stripe design the 10*10*4mm patch antenna. The front end SAW filter reduces the risks where there is a cellular transmitter nearby of interference from out of band frequencies which can cause LNA burn-out, saturation, or radiated spurious emissions.

This product is suited to small form factor mobile devices such as GPS Smartphones, Personal Location, Medical devices, Telematic devices and Automotive navigation and tracking. Custom gain, connector and cable versions are available.

Custom tuning is available for specific customer device environments and is dependent on a minimum order quantity and NRE in some cases. Please contact regional sales office for details.

The AP.10E consists of 2 functional blocks – the LNA and also the patch antenna.

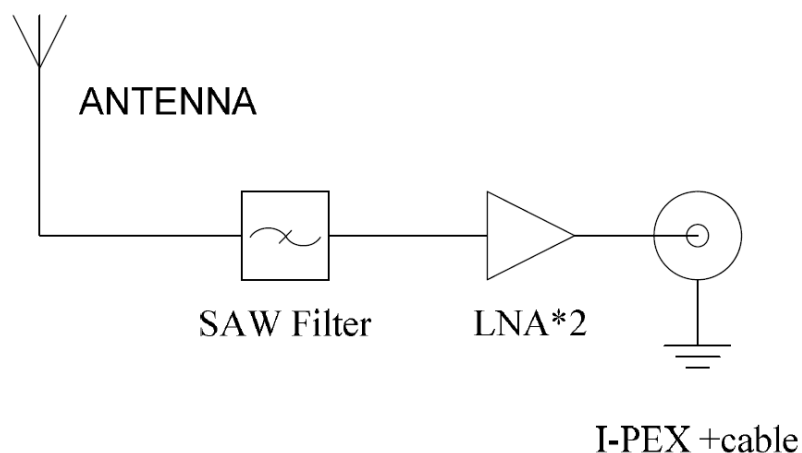

2. Specification

ANTENNA			
Frequency	1575.42 ± 1.023MHz		
Gain @ Zenith	-10dBic Typ. @ Zenith		
Polarization	RHCP		
Axial Ratio	4.0dB max. @Zenith		
Patch Dimension	10*10*4.0mm		
LNA			
Frequency	1575.42 ± 1.023MHz F0=1575.42MHz		
Outer Band Attenuation	F0±30MHz 5dB min. F0±50MHz 20dB min. F0±100MHz 25dB min.		
Output Impedance	50Ω		
Output VSWR	2.0 Max		
Pout at 1dB Gain Compression point	Typ. 11 dBm Min. 8 dBm		
LNA Gain, Power Consumption and Noise Figure			
	LNA Gain	Power Consumption(mA)	Noise Figure
Voltage	(Typ)	Typ	Typ
Min. 1.8V	20dB	5mA	2.7dB
Typ. 3.0V	25dB	10mA	2.5dB
Max. 5.5V	25dB	23mA	2.7dB

CABLE AND CONNECTOR	
RF Cable	Coaxial Cable $\varnothing 0.81 \pm 0.1\text{mm}$, length $39 \pm 2.0\text{mm}$
Connector	IPEX MHFI (U.FL)
ANTENNA, LNA, CABLE AND CONNECTOR	
Frequency	$1575.42 \pm 1.023\text{MHz}$
Gain	At 3V: $15 \pm 4\text{dBic}@90^\circ$
Output Impedance	50Ω
Polarization	RHCP
Output VSWR	Max 2.0
Operation Temperature	-40°C to $+ 85^\circ\text{C}$
Storage Temperature	-40°C to $+ 105^\circ\text{C}$
Relative Humidity	40% to 95%
Input Voltage	Min:1.8V Typ. 3.0V Max:5.5V
Antenna	$10*10*4\text{mm}$

3. LNA Gain and Out Band Rejection @3.0V

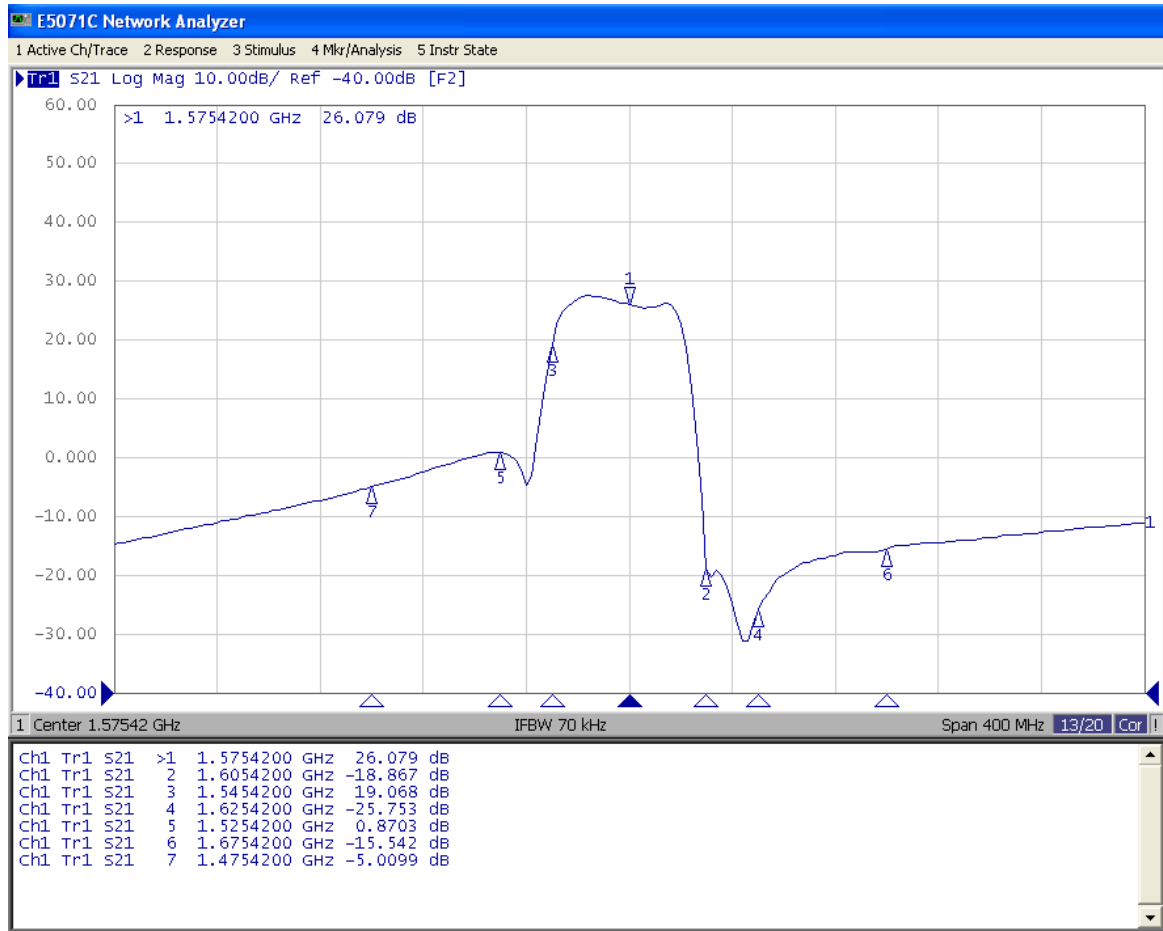

4. LNA Noise Figure @3.0V

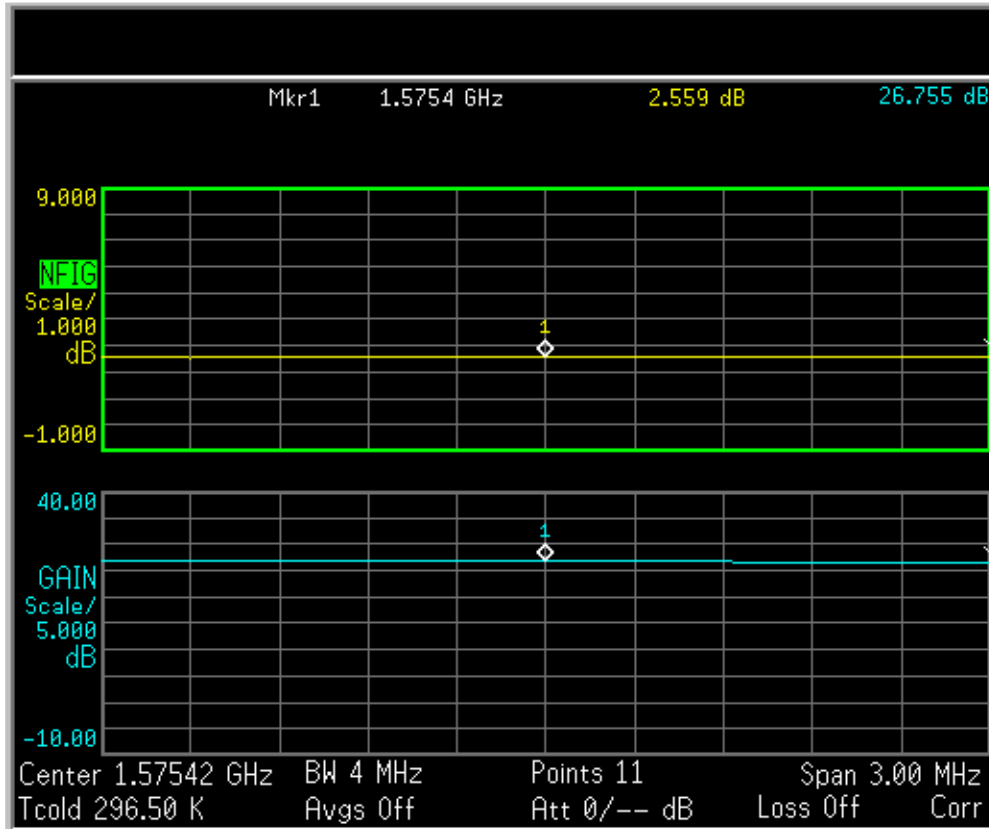

XZ Plane Radiation

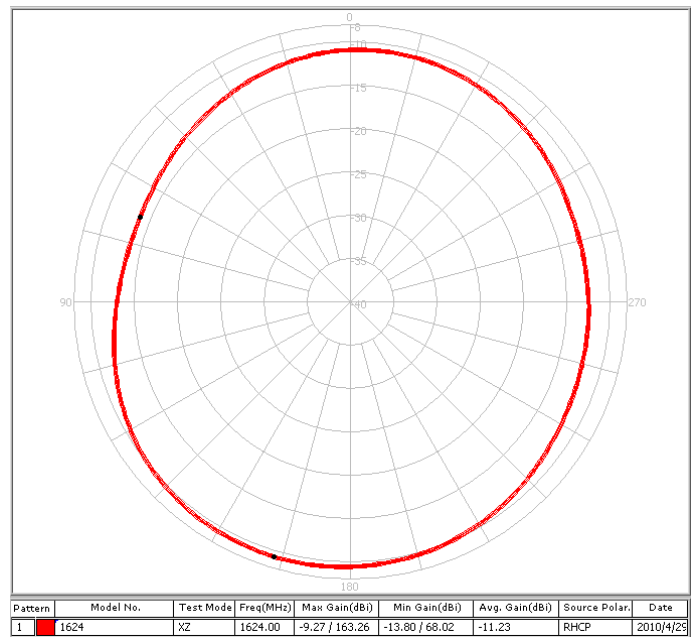

YZ Plane Radiation

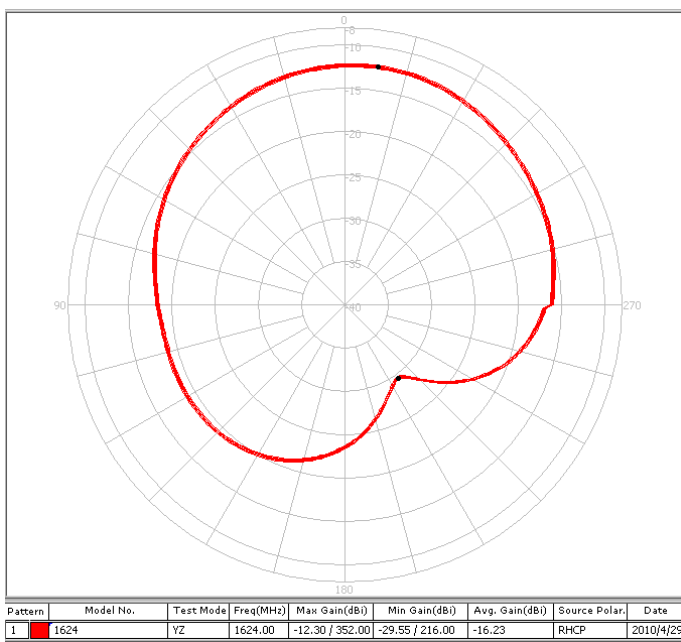

XY Plane Radiation

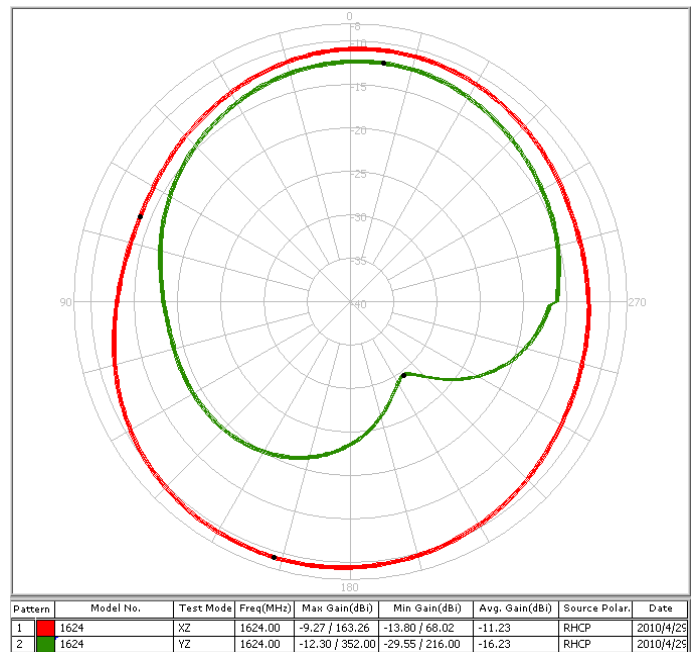

5. Antenna Drawing

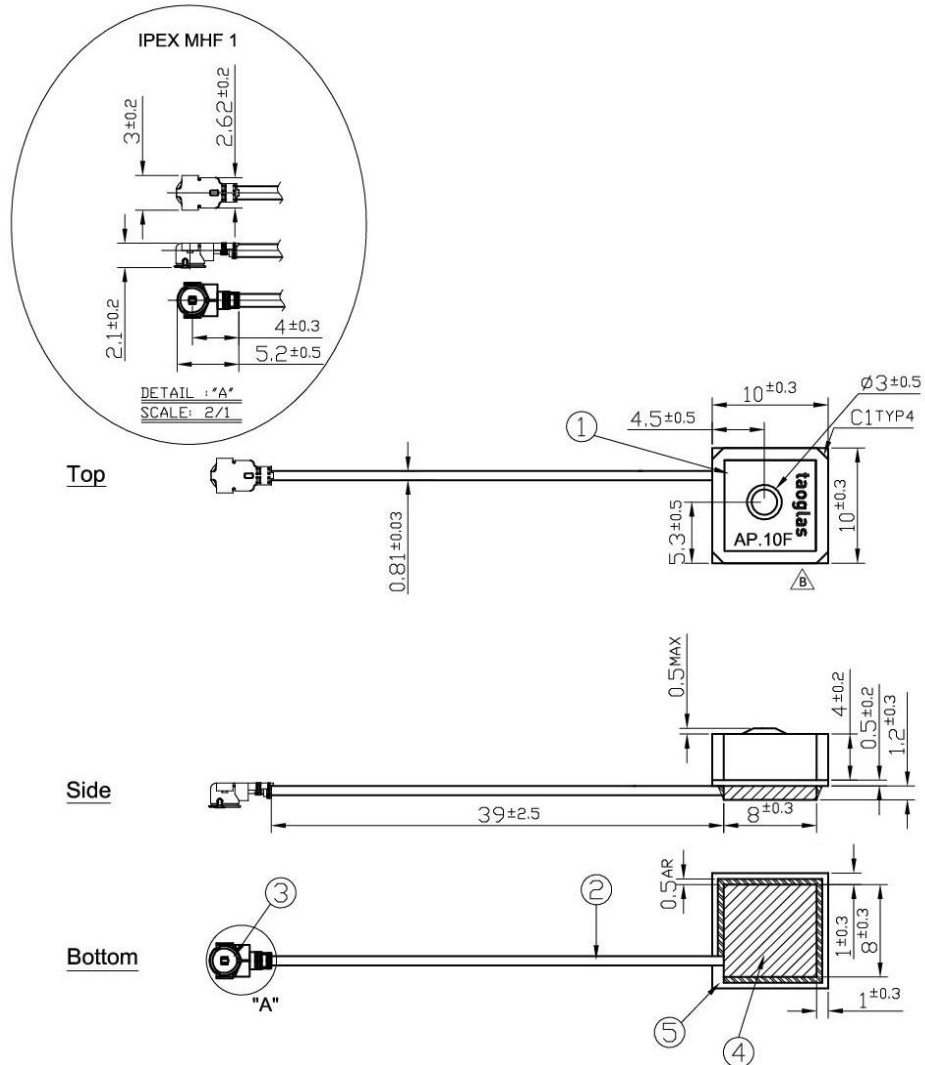

	Name	Material	Finish	QTY
1	AP.10F Patch(10*10*4mm)	Ceramic	Clear	1
2	0.81 Coaxial Cable	FEP	Gray	1
3	IPEX MHF1	Brass	Gold	1
4	Shielding Case	Tin (SPTE)	Tin Plated	1
5	PCB	FR4 0.5t	Green	1

6. Plugs Usage Precautions

6.1. Mating / unmating

- (1) To disconnect connectors, insert the end portion of I-PEX under the connector flanges and pull off vertically, in the direction of the connector mating axis.
- (2) To mate the connectors, the mating axes of both connectors must be aligned and the connectors can be mated. The "click" will confirm fully mated connection. Do not attempt to insert on an extreme angle.

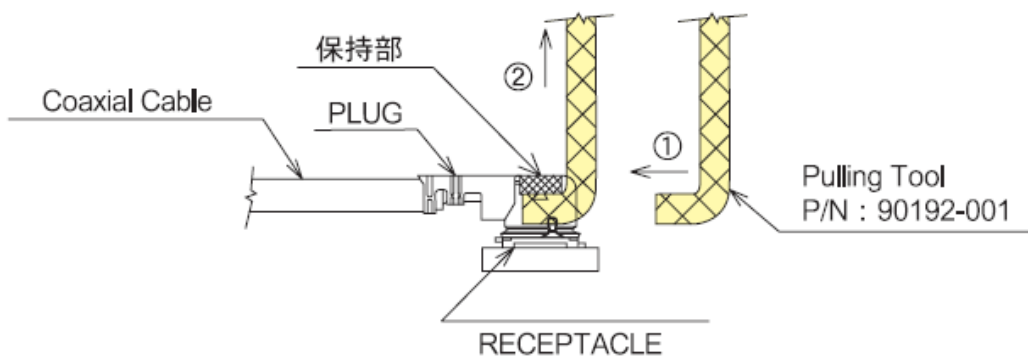

6.2. Pull forces on the cable after connectors are mated

After the connectors are mated, do not apply a load to the cable in excess of the values indicated in the diagram below.

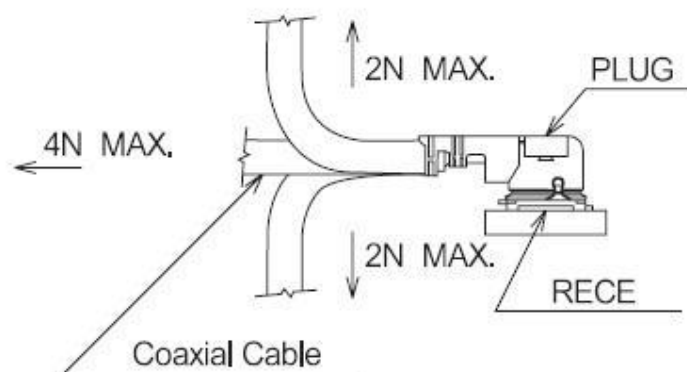

7. Packaging

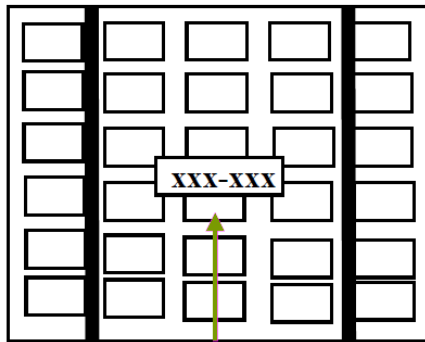

- *Packaged in Tray with Foam
- *One Tray = 60 pieces
- *6 Trays per Section = 360 pcs

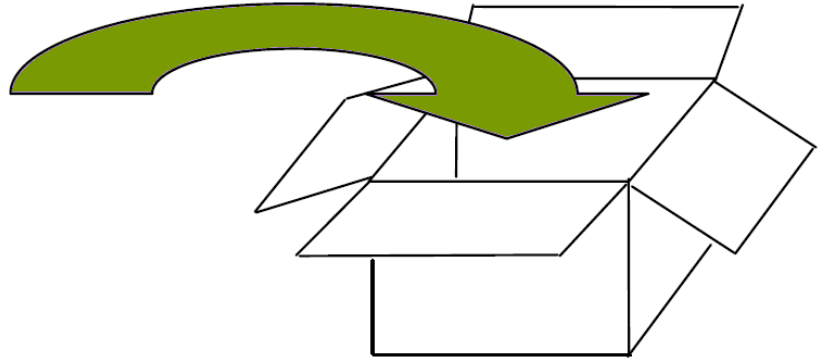

- *Each Carton contains 3 Sections
- *1080 pieces per Carton

Taoglas makes no warranties based on the accuracy or completeness of the contents of this document and reserves the right to make changes to specifications and product descriptions at any time without notice. Taoglas reserves all rights to this document and the information contained herein.

Reproduction, use or disclosure to third parties without express permission is strictly prohibited.

Copyright © Taoglas Ltd.



Компания «ЭлектроПласт» предлагает заключение долгосрочных отношений при поставках импортных электронных компонентов на взаимовыгодных условиях!

Наши преимущества:

- Оперативные поставки широкого спектра электронных компонентов отечественного и импортного производства напрямую от производителей и с крупнейших мировых складов;
- Поставка более 17-ти миллионов наименований электронных компонентов;
- Поставка сложных, дефицитных, либо снятых с производства позиций;
- Оперативные сроки поставки под заказ (от 5 рабочих дней);
- Экспресс доставка в любую точку России;
- Техническая поддержка проекта, помощь в подборе аналогов, поставка прототипов;
- Система менеджмента качества сертифицирована по Международному стандарту ISO 9001;
- Лицензия ФСБ на осуществление работ с использованием сведений, составляющих государственную тайну;
- Поставка специализированных компонентов (Xilinx, Altera, Analog Devices, Intersil, Interpoint, Microsemi, Aeroflex, Peregrine, Syfer, Eurofarad, Texas Instrument, Miteq, Cobham, E2V, MA-COM, Hittite, Mini-Circuits, General Dynamics и др.);

Помимо этого, одним из направлений компании «ЭлектроПласт» является направление «Источники питания». Мы предлагаем Вам помощь Конструкторского отдела:

- Подбор оптимального решения, техническое обоснование при выборе компонента;
- Подбор аналогов;
- Консультации по применению компонента;
- Поставка образцов и прототипов;
- Техническая поддержка проекта;
- Защита от снятия компонента с производства.



Как с нами связаться

Телефон: 8 (812) 309 58 32 (многоканальный)

Факс: 8 (812) 320-02-42

Электронная почта: org@eplast1.ru

Адрес: 198099, г. Санкт-Петербург, ул. Калинина, дом 2, корпус 4, литера А.