

# Future Technology Devices International Ltd

## Datasheet

### VMusic3 Vinculum-II Application Module



*VMusic3 is a USB host and MP3/WMA Player application module with an enclosure. The default firmware of the VMusic3 supports audio playback and UART/SPI communications with the embedded USB host controller and USB host port. VMusic3 can be used to read MP3 and other audio format files from a USB flash disk process the data and output the stereo audio through the line-out header and headphone jack.*

## 1 Introduction

VMusic3 is designed to support quick and easy integration of a UART/SPI application with a USB client device. VMusic3 also supports playback of MP3 and WMA. The VMusic3 is packaged in a neat enclosure displaying a bi-colour LED, making it suitable for incorporating into finished product designs.

The VMusic3 utilises FTDI's Vinculum-II (VNC2-48L1B) dual USB host controller IC. This IC is a microcontroller and USB host controller; it can be reprogrammed using the UART interface or the Vinculum-II debugger module interface connector. The default firmware used is V2MSC, this firmware supports the UART/SPI to USB host interface and MP3 playback. This firmware can be modified or replaced with another firmware.

The VMusic3 also utilises VLSI Solution's VS1053b compressed audio codec to provide the audio playback feature. This chip operates with the Vinculum-II and supporting firmware when reading MP3 and WMA files from a USB flash drive. The VS1053b processes this data and outputs the stereo audio to the headphone jack and line-out header. Connecting headphones or speakers to either of these ports transduces the audio data into sound.

For details on the Vinculum-II collateral please click <http://www.ftdichip.com/Products/ICs/VNC2.htm>.

## 1.1 Features

VMusic3 has the following features:

- MP3 and WMA playback
- Vinculum-II microcontroller/USB host controller IC.
- USB "A" type socket to connect to USB client devices.
- 2mm (0.08") pitch 8 pin header used for the UART/SPI interface.
- Connects directly and communicates with a FTDI TTL-232R-3V3-2mm USB-UART cable.
- Jumper selectable UART and SPI interfaces, both operating 3.3V TTL/CMOS.
- Pre-programmed with V2MSC firmware.
- Vinculum-II debugger module port under the enclosure, for changing the firmware and debugging.
- UART programming mode control pins PROG# and RESET# are connected to an internal header.
- Reprogrammable over USB Port from flash drive.
- The VMusic3 and all components used are Pb-free (RoHS compliant).

## Table of Contents

<b>1</b>	<b>Introduction .....</b>	<b>1</b>
1.1	<b>Features.....</b>	<b>1</b>
<b>2</b>	<b>Ordering Information .....</b>	<b>3</b>
<b>3</b>	<b>VMusic3 Signals and Configurations .....</b>	<b>3</b>
3.1	<b>VMusic3 Pin-Out.....</b>	<b>3</b>
3.2	<b>VMusic3 Jumper Configuration.....</b>	<b>3</b>
3.3	<b>Interface Discriptions .....</b>	<b>4</b>
<b>4</b>	<b>VMusic2 and VMusic3 comparisons.....</b>	<b>4</b>
<b>5</b>	<b>VMusic3 Application Examples.....</b>	<b>5</b>
5.1	<b>UART Interface to PIC Example.....</b>	<b>5</b>
<b>6</b>	<b>VMusic3 Commands Details .....</b>	<b>6</b>
<b>7</b>	<b>VMusic3 Electrical Details.....</b>	<b>7</b>
7.1	<b>SPI Interface Timing .....</b>	<b>7</b>
<b>8</b>	<b>VMusic3 Max-Ratings .....</b>	<b>9</b>
<b>9</b>	<b>VMusic3 Mechanical Details.....</b>	<b>9</b>
<b>10</b>	<b>VMusic3 Circuit Schematic.....</b>	<b>10</b>
<b>11</b>	<b>Contact Information .....</b>	<b>11</b>
	<b>Appendix A - List of Figures and Tables.....</b>	<b>13</b>
	<b>Appendix B – Revision History .....</b>	<b>14</b>

## 2 Ordering Information

Module Code	Utilised IC Code	Description
VMUSIC3	VNC2-48L1B	USB host application module with MP3 playback and enclosure.

## 3 VMusic3 Signals and Configurations

### 3.1 VMusic3 Pin-Out

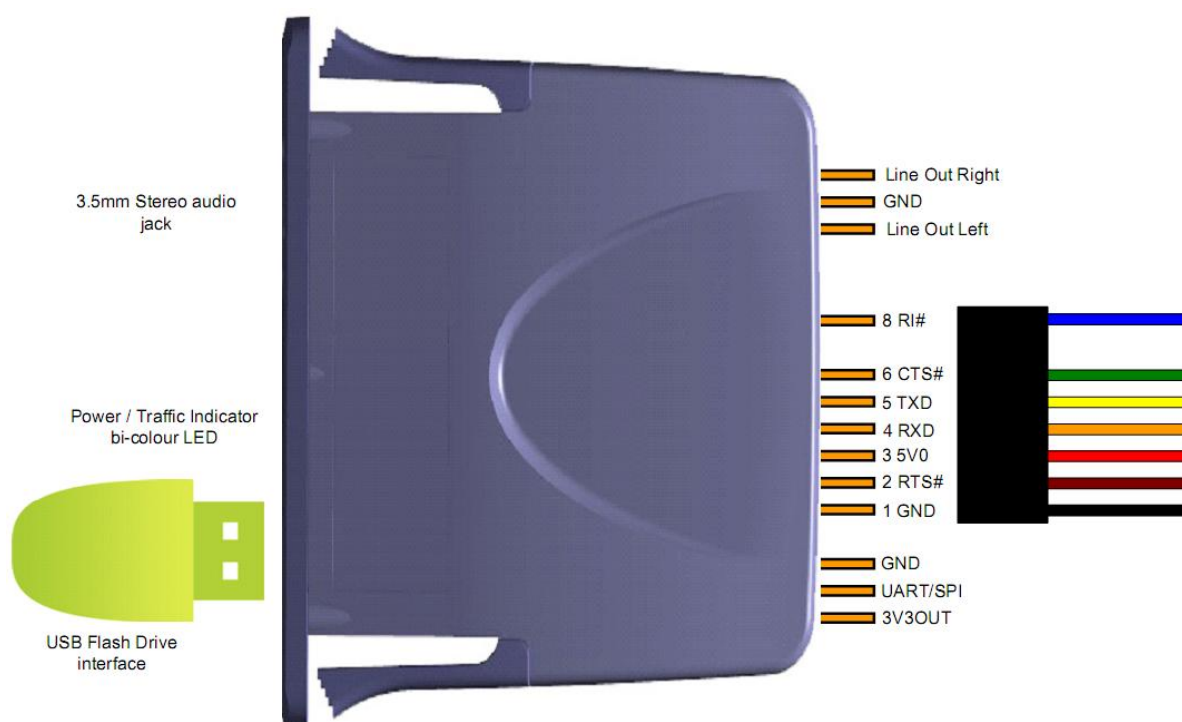

**Figure 3.1 – VMusic3 Pin Out (in UART mode)**

The pin-out is illustrated in Figure 3.1.

### 3.2 VMusic3 Jumper Configuration

The VMusic3 comes preloaded with the V2MSC firmware and the jumper is set to UART mode by default. Adjusting the jumpers accordingly configures the module to operate in SPI mode.

The interface modes of the VMusic3 running on a V2MSC firmware are given in Table 3.1

UART/SPI	Interface Mode
Pull-Up	UART
Pull-Down	SPI

**Table 3.1 – VMusic3 Jumper Box**

### 3.3 Interface Discriptions

Pin No.	Name	Type	Description
1	GND	PWR	Signal ground
2	RTS#	Output	Request To Send control output – Handshake signal
3	5V0	PWR	5V supply input
4	RXD	Input	Receive asynchronous data input
5	TXD	Output	Transmit asynchronous data output
6	CTS#	Input	Clear To Send control input - Handshake signal
7	NC	-	No Connect
8	RI#/WU	Input	Ring Indicator control input / Wake Up

**Table 3.2 – 3.3V TTL/CMOS UART Pin Out**

Pin No.	Name	Type	Description
5	CLK	Input	SPI clock input. Maximum frequency: 24MHz.
4	MOSI	Input	SPI slave serial data input
2	MISO	Output	SPI slave serial data output
6	SS#	Input	SPI slave select input

**Table 3.3 – 3.3V TTL/CMOS SPI Pin Out**

For further details see VNC2 datasheet.

## 4 VMusic2 and VMusic3 comparisons

The VMusic3 is a drop in replacement for the VMusic2 for the majority of VMusic2 applications. VMusic3 uses firmware called V2MSC which is similar to V2DAP (used in VDRIVE3) with an additional module for controlling MP3 playback. However for a small number of applications that use SPI, differences exists between VMUSIC firmware and V2MSC firmware which would require some changes to be made to the application software. For further details on this discrepancy please see [AN 176 - Vinculum Comparison of VDAP and V2DAP](#).

Additional features of the VMusic3:

- Vinculum-II can be configured by a user defined firmware
- VMusic3 has an SPI master interface available (not enabled in V2MSC firmware).
- VMusic3's SPI interface can be clocked up to 24MHz
- VMusic3 can be programmed using the debugger-module port in addition to programming using the UART interface port.
- VMusic3 can utilise many of the Vinculum-II sample firmware available on the FTDI website.

## 5 VMusic3 Application Example

VMusic3 can be used to play audio from a flash disk. An example is given where a PIC is used to send commands to the VMusic3 select playing option such as play, pause and skip.

It is also possible to control the VMusic3 from a PC using a [TTL-232R-3V3-2mm](#) and a terminal. See [Vinculum Firmware User Manual](#) for details on the control commands.

### 5.1 UART Interface to PIC Example

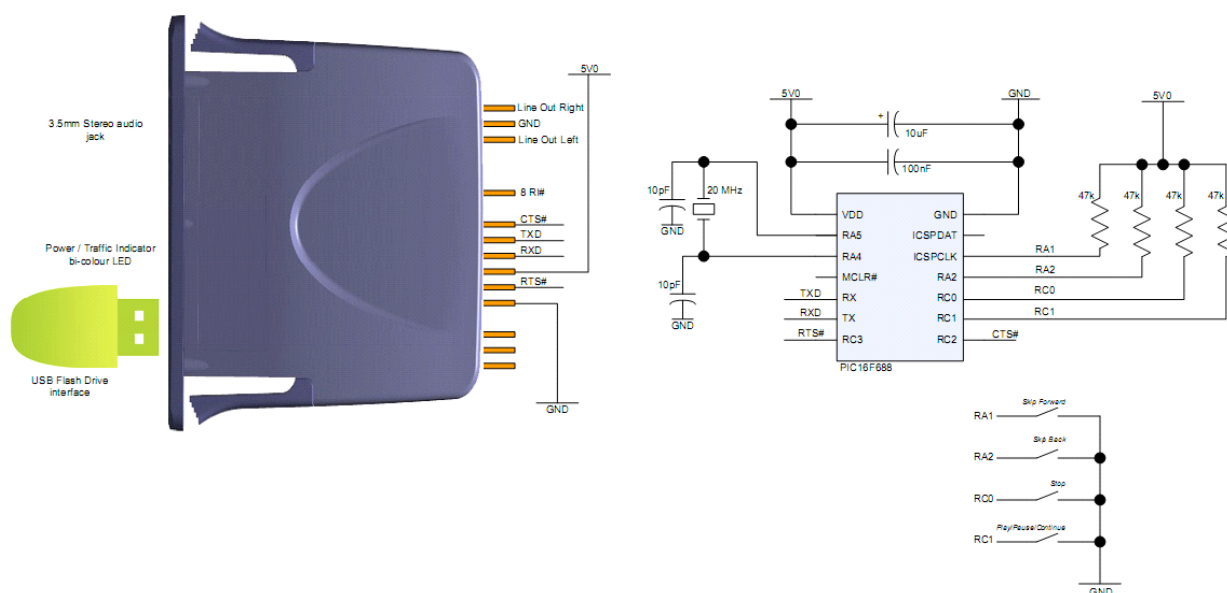

**Figure 5.1 – MP3 playback using VMusic3 controlled by a PIC MCU**

A VMusic2 compatible example is given in Figure 5.1. This example shows a VMusic3 interfacing with an external PIC MCU and supporting components. In this example four push buttons are used to control play / pause, stop, skip forward / volume up and skip back / volume down of the MP3 player.

For more information on this application see VMUSIC SPI PIC Sample on the following web page:

<http://www.ftdichip.com/Support/SoftwareExamples/VinculumProjects.htm>

## 6 VMusic3 Commands Details

The command set for the VMusic3 is given in Table 6.1.

For more details on Vinculum commands please see:

[http://www.ftdichip.com/Firmware/Precompiled/UM\\_VinculumFirmware\\_V205.pdf](http://www.ftdichip.com/Firmware/Precompiled/UM_VinculumFirmware_V205.pdf)

Extended Command Set	Short Command Set (Hexadecimal Codes)	Function
VPF·file ↵	1D 20 file 0D	Plays a single file
VRF·file ↵	89 20 file 0D	Repeatedly plays a single file
VST ↵	20 0D	Stops playback
V3A ↵	21 0D	Plays all MP3 files
VRA ↵	8A 0D	Repeatedly plays all MP3 files
VRR ↵	8F 0D	Repeatedly plays random MP3 files
VSF ↵	25 0D	Skip forward one track
VSB ↵	26 0D	Skip back one track
VSD ↵	8E 0D	Skip forward on whole directory
VP ↵	8B 0D	Pause playback
VF ↵	8C 0D	Fast forward 5 seconds
VB ↵	8D 0D	Rewind 5 seconds
VRD·byte ↵	1F 20 byte 0D	Reads command register
VWR·byte+word ↵	1E 20 byte word 0D	Writes command register
VSV·byte ↵	88 20 byte 0D	Sets playback volume

**Table 6.1 – V2MSC Command Set**

## 7 VMusic3 Electrical Details

### 7.1 SPI Interface Timing

The following timing diagrams are for the VNC1L Legacy Interface mode of SPI slave.

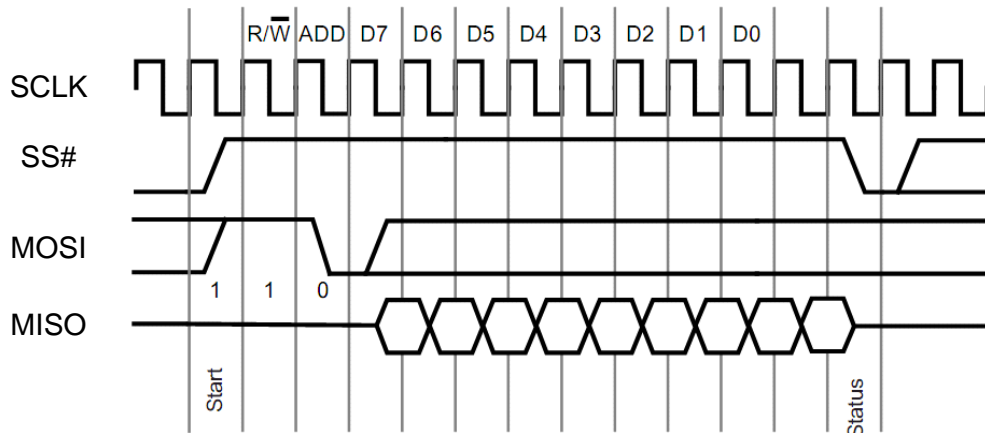
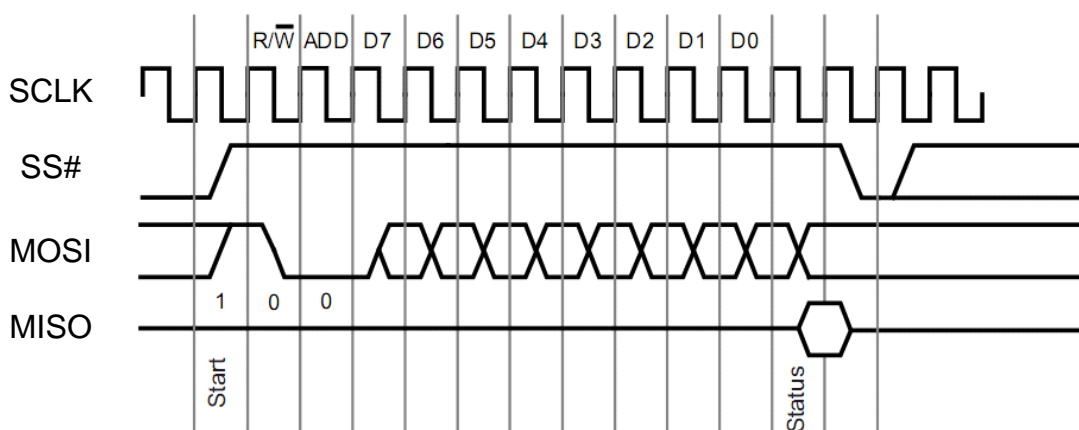

**Figure 7.1 – SPI**

To start the data transfer process SS# needs to be set high, and remain high for the entire read cycle. Once the read cycle completes SS# needs to be set low for at least one clock cycle to allow another data transfer cycle to occur.

The first bit of MOSI is the R/W bit, receiving a logic high for this bit allows data to be read from the VMusic3. The second bit is the address bit, ADD, this bit is used to select reading data from the data register when set to logic high, or from the status register when set to logic low. During an SPI Read cycle a package of data is transmitted from the VMusic3 on the MISO line from the time of the first clock cycle after the SPI ADD bit, with the MSB transmitted first.

After the data has been transferred the status of MISO can be checked to determine if the data read is new data that has not been read before, which is indicated by a transmitted logic low. Otherwise if old data is being transmitted, which is indicated by a transmitted logic high, the read cycle needs to be repeated to get new data.

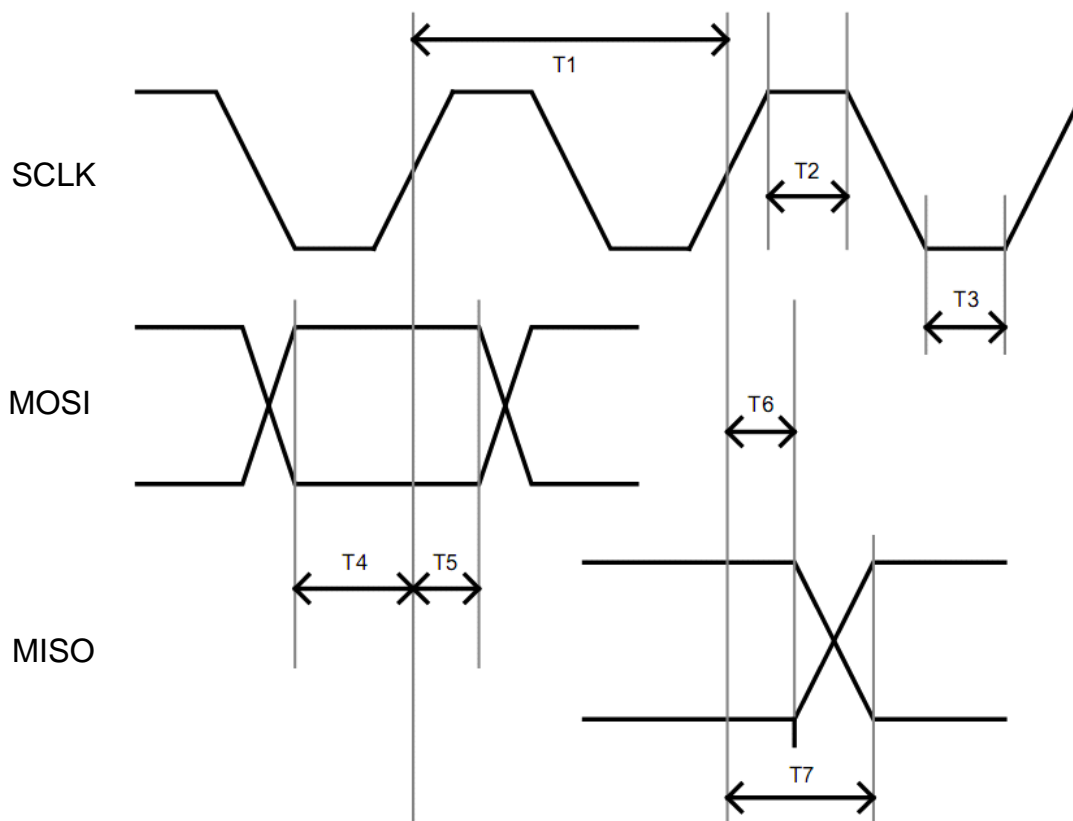

**Figure 7.2 – VMusic3 SPI Waveforms**

To start the data transfer process SPI SS# needs to be set high, and remain high for the entire write cycle. Once the write cycle SPI completes SS# needs to be set low for at least one clock cycle to allow another data transfer cycle to occur. The first bit of MOSI is the R/W bit, receiving a logic low for this bit allows data to be written to the VMusic3.

The second bit is the address bit, ADD, this bit is used to select a data write to the data register when set to logic high, and to the status register when set to logic low. During an SPI Write cycle a package of data is transmitted to the VMusic3 on the MOSI line from the first clock cycle after the SPI ADD bit, with the MSB transmitted first.

After the data has been transferred the status of MISO can be checked to determine if the data written has been accepted. If a logic low is given for the status bit, it can be determined from this that the data write was successful. If logic high is given for the status bit, the internal buffer of the device receiving data is full, and the same write cycle should be repeated.



**Figure 7.3 – VMusic3 SPI Timing**

Time	Description	Min	Typical	Max	Unit
T1	SCLK Period	83	-	-	ns
T2	SCLK High	20	-	-	ns
T3	SCLK Low	20	-	-	ns
T4	Input Setup Time	10	-	-	ns
T5	Input Setup Time	10	-	-	ns
T6	Input Hold Time	2	-	-	ns
T7	Output Valid Time	-	-	20	ns

**Table 7.1 – SPI Timing Table**



## 8 VMusic3 Max-Ratings

The absolute maximum ratings for the VDrive3 devices are as follows. These are in accordance with the Absolute Maximum Rating System (IEC 60134). Exceeding these may cause permanent damage to the device.

Parameter	Value	Unit	Conditions
Storage Temperature	-40°C to 85°C	Degrees C	
Ambient Operating Temperature (Power Applied)	-30°C to 85°C	Degrees C	
VCC Supply Voltage	-0.3 to +5.5	V	
DC Input Voltage – USBDP and USBDM	-0.5 to +3.63	V	

**Table 8.1 – Absolute Maximum Ratings**

## 9 VMusic3 Mechanical Details

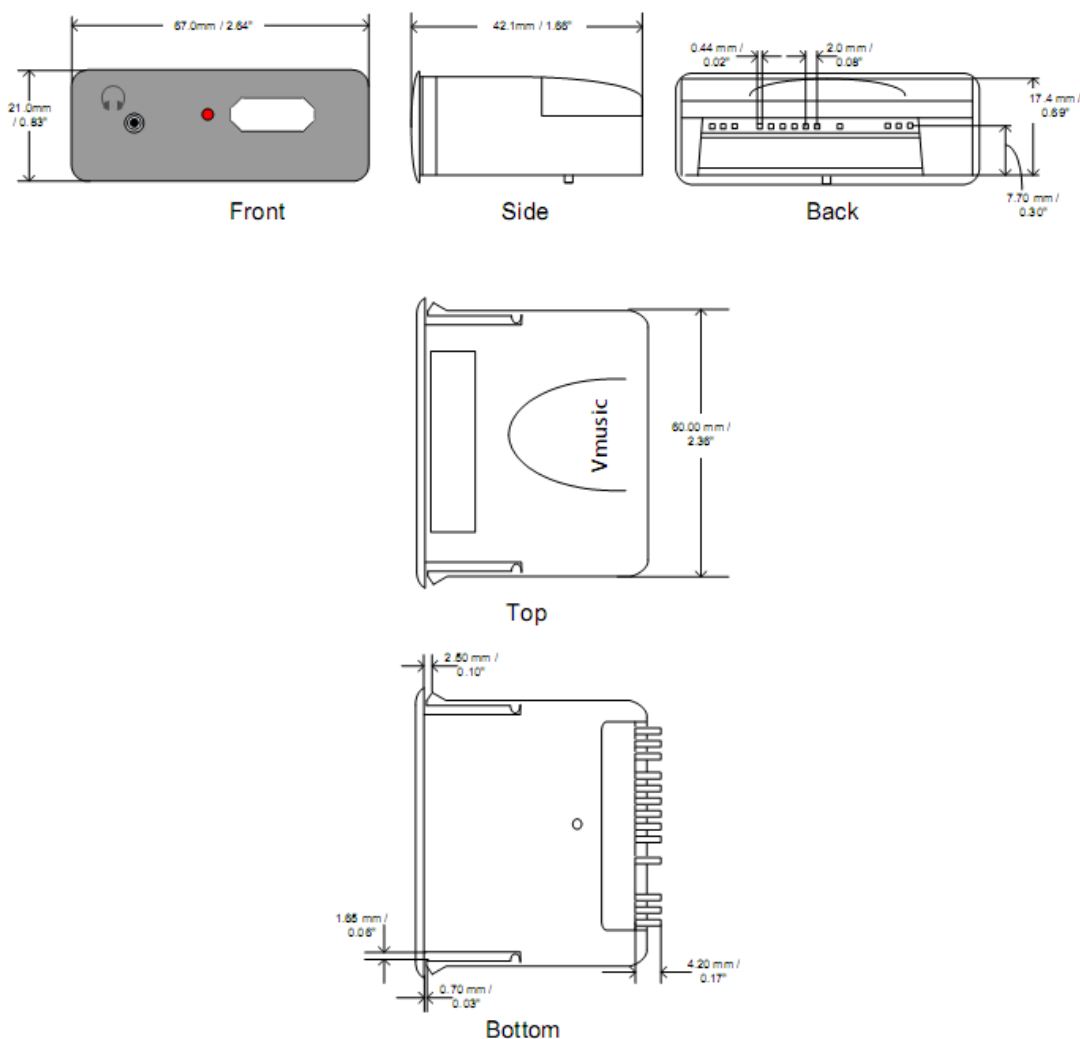

**Figure 9.1 – VMusic3 Dimensions**

# 10 VMusic3 Circuit Schematic

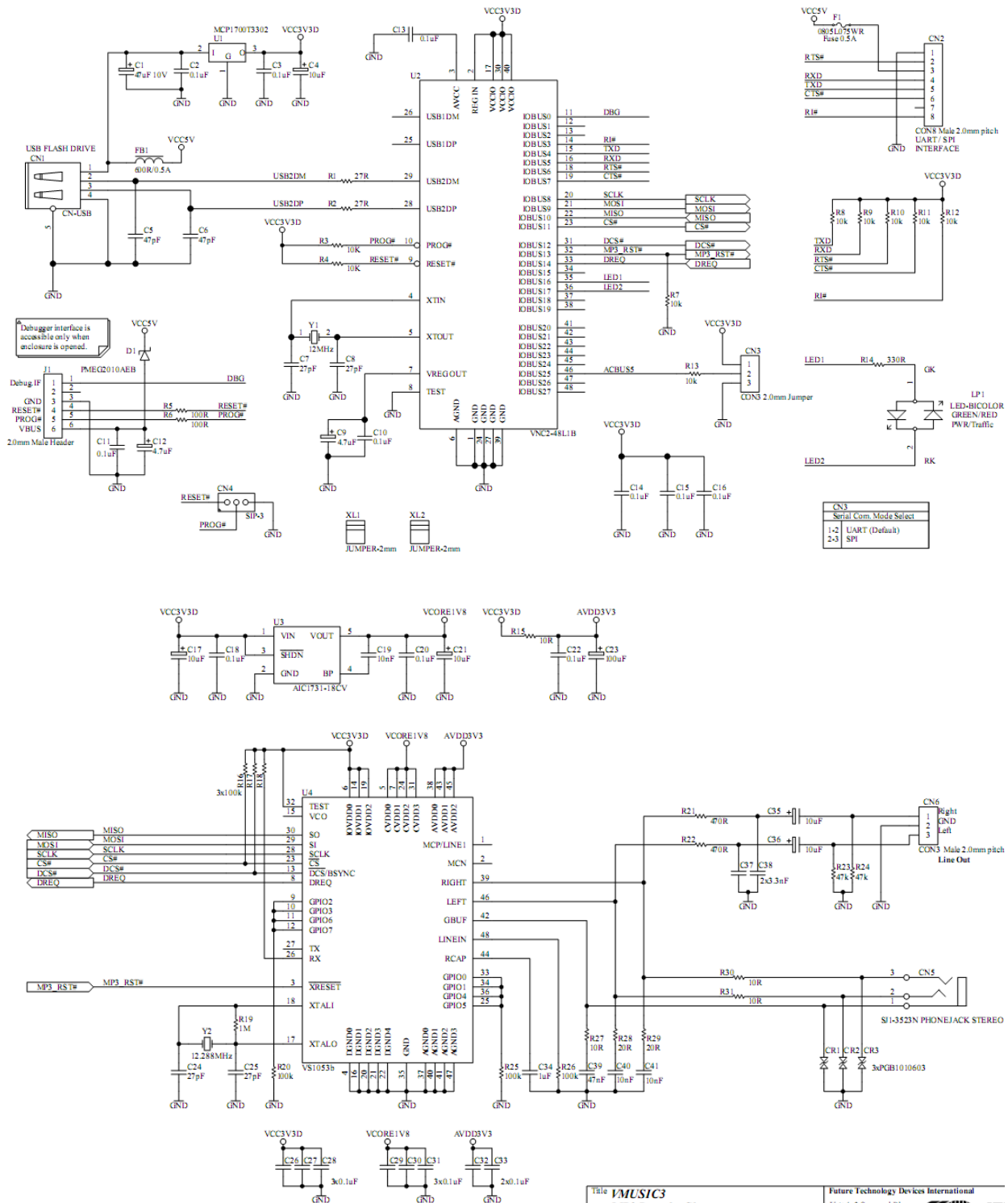

Figure 10.1 – Module Circuit Schematic

## 11 Contact Information

### Head Office – Glasgow, UK

Future Technology Devices International Limited  
Unit 1, 2 Seaward Place, Centurion Business Park  
Glasgow G41 1HH  
United Kingdom  
Tel: +44 (0) 141 429 2777  
Fax: +44 (0) 141 429 2758

E-mail (Sales) [sales1@ftdichip.com](mailto:sales1@ftdichip.com)  
E-mail (Support) [support1@ftdichip.com](mailto:support1@ftdichip.com)  
E-mail (General Enquiries) [admin1@ftdichip.com](mailto:admin1@ftdichip.com)

### Branch Office – Hillsboro, Oregon, USA

Future Technology Devices International Limited (USA)  
7130 SW Fir Loop  
Tigard, OR 97223-8160  
USA  
Tel: +1 (503) 547 0988  
Fax: +1 (503) 547 0987

E-Mail (Sales) [us.sales@ftdichip.com](mailto:us.sales@ftdichip.com)  
E-Mail (Support) [us.support@ftdichip.com](mailto:us.support@ftdichip.com)  
E-Mail (General Enquiries) [us.admin@ftdichip.com](mailto:us.admin@ftdichip.com)

### Branch Office – Taipei, Taiwan

Future Technology Devices International Limited (Taiwan)  
2F, No. 516, Sec. 1, NeiHu Road  
Taipei 114  
Taiwan, R.O.C.  
Tel: +886 (0) 2 8797 1330  
Fax: +886 (0) 2 8751 9737

E-mail (Sales) [tw.sales1@ftdichip.com](mailto:tw.sales1@ftdichip.com)  
E-mail (Support) [tw.support1@ftdichip.com](mailto:tw.support1@ftdichip.com)  
E-mail (General Enquiries) [tw.admin1@ftdichip.com](mailto:tw.admin1@ftdichip.com)

### Branch Office – Shanghai, China

Future Technology Devices International Limited (China)  
Room 408, 317 Xianxia Road,  
Shanghai, 200051  
China  
Tel: +86 21 62351596  
Fax: +86 21 62351595

E-mail (Sales) [cn.sales@ftdichip.com](mailto:cn.sales@ftdichip.com)  
E-mail (Support) [cn.support@ftdichip.com](mailto:cn.support@ftdichip.com)  
E-mail (General Enquiries) [cn.admin@ftdichip.com](mailto:cn.admin@ftdichip.com)

### Web Site

<http://ftdichip.com>

### Distributor and Sales Representatives

Please visit the Sales Network page of the [FTDI Web site](#) for the contact details of our distributor(s) and sales representative(s) in your country.

System and equipment manufacturers and designers are responsible to ensure that their systems, and any Future Technology Devices International Ltd (FTDI) devices incorporated in their systems, meet all applicable safety, regulatory and system-level performance requirements. All application-related information in this document (including application descriptions, suggested FTDI devices and other materials) is provided for reference only. While FTDI has taken care to assure it is accurate, this information is subject to customer confirmation, and FTDI disclaims all liability for system designs and for any applications assistance provided by FTDI. Use of FTDI devices in life support and/or safety applications is entirely at the user's risk, and the user agrees to defend, indemnify and hold harmless FTDI from any and all damages, claims, suits or expense resulting from such use. This document is subject to change without notice. No freedom to use patents or other intellectual property rights is implied by the publication of this document. Neither the whole nor any part of the information contained in, or the product described in this document, may be adapted or reproduced in any material or electronic form without the prior written consent of the copyright holder. Future Technology Devices International Ltd, Unit 1, 2 Seaward Place, Centurion Business Park, Glasgow G41 1HH, United Kingdom. Scotland Registered Company Number: SC136640

---

## **Appendix A - List of Figures and Tables**

### **List of Figures**

<b>Figure 3.1 – VMusic3 Pin Out (in UART mode)</b> .....	<b>3</b>
<b>Figure 7.2 – VMusic3 SPI Waveforms</b> .....	<b>7</b>
<b>Figure 7.3 – VMusic3 SPI Timing</b> .....	<b>8</b>
<b>Figure 9.1 – VMusic3 Dimensions</b> .....	<b>9</b>
<b>Figure 10.1 – Module Circuit Schematic</b> .....	<b>10</b>

### **List of Tables**

<b>Table 3.1 – VMusic3 Jumper Box</b> .....	<b>3</b>
<b>Table 7.1 – SPI Timing Table</b> .....	<b>8</b>
<b>Table 8.1 – Absolute Maximum Ratings</b> .....	<b>9</b>

## Appendix B – Revision History

Document Title: VMusic3  
Document Reference No.: FT\_000738  
Clearance No.: FTDI# 336  
Product Page: <http://www.ftdichip.com/Products/ICs/VNC2.htm>  
Document Feedback: [Send Feedback](#)

**Version 1.0** First release 10/04/12



Компания «ЭлектроПласт» предлагает заключение долгосрочных отношений при поставках импортных электронных компонентов на взаимовыгодных условиях!

Наши преимущества:

- Оперативные поставки широкого спектра электронных компонентов отечественного и импортного производства напрямую от производителей и с крупнейших мировых складов;
- Поставка более 17-ти миллионов наименований электронных компонентов;
- Поставка сложных, дефицитных, либо снятых с производства позиций;
- Оперативные сроки поставки под заказ (от 5 рабочих дней);
- Экспресс доставка в любую точку России;
- Техническая поддержка проекта, помощь в подборе аналогов, поставка прототипов;
- Система менеджмента качества сертифицирована по Международному стандарту ISO 9001;
- Лицензия ФСБ на осуществление работ с использованием сведений, составляющих государственную тайну;
- Поставка специализированных компонентов (Xilinx, Altera, Analog Devices, Intersil, Interpoint, Microsemi, Aeroflex, Peregrine, Syfer, Eurofarad, Texas Instrument, Miteq, Cobham, E2V, MA-COM, Hittite, Mini-Circuits, General Dynamics и др.);

Помимо этого, одним из направлений компании «ЭлектроПласт» является направление «Источники питания». Мы предлагаем Вам помощь Конструкторского отдела:

- Подбор оптимального решения, техническое обоснование при выборе компонента;
- Подбор аналогов;
- Консультации по применению компонента;
- Поставка образцов и прототипов;
- Техническая поддержка проекта;
- Защита от снятия компонента с производства.



#### Как с нами связаться

**Телефон:** 8 (812) 309 58 32 (многоканальный)

**Факс:** 8 (812) 320-02-42

**Электронная почта:** [org@eplast1.ru](mailto:org@eplast1.ru)

**Адрес:** 198099, г. Санкт-Петербург, ул. Калинина, дом 2, корпус 4, литера А.