

HDSP-078x, HDSP-079x, HDSP-088x, HDSP-098x

Glass/Ceramic Numeric and Hexadecimal Displays for Industrial Applications

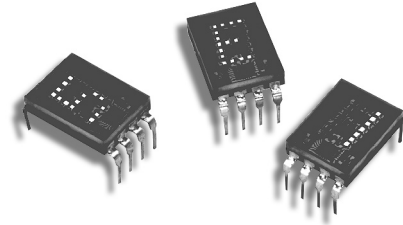

Data Sheet



Description

These standard solid state displays have a 7.4 mm (0.29 inch) dot matrix character and an on-board IC with data memory latch/decoder and LED drivers in a glass/ceramic package.

The hermetic HDSP-078x,-079x/-088x displays utilize a solder glass frit seal. The HDSP-098X displays utilize an epoxy glass-to-ceramic seal.

The numeric devices decode positive BCD logic into characters "0-9," a "-" sign, decimal point, and a test pattern. The hexadecimal devices decode positive BCD logic into 16 characters, "0-9, A-F." An input is provided on the hexadecimal devices to blank the display (all LEDs off) without losing the contents of the memory.

The over range device displays "±1" and right hand decimal point and is typically driven via external switching transistors.

Features

- Three character options
Numeric, hexadecimal, over range
- Three colors;
High Efficiency Red, Yellow, High Performance Green
- 4x7 dot matrix character
- Two high efficiency red options
Low power, high brightness
- Performance guaranteed over temperature
- High temperature stabilized
- Memory latch/decoder/driver
TTL compatible
- Categorized for luminous intensity

Devices

Part Number	Color	Description	Front View
0781	High-Efficiency Red	Numeric, Right Hand DP	A
0782	Low Power	Numeric, Left Hand DP	B
0783		Over Range ±1	C
0784		Hexadecimal	D
0791	High-Efficiency Red	Numeric, Right Hand DP	A
0792	High Brightness	Numeric, Left Hand DP	B
0794		Hexadecimal	D
0881	Yellow	Numeric, Right Hand DP	A
0883		Over Range ±1	C
0884		Hexadecimal	D
0981	High-Performance	Numeric, Right Hand DP	A
0983	Green	Over Range ±1	C
0984		Hexadecimal	D

Package Dimensions

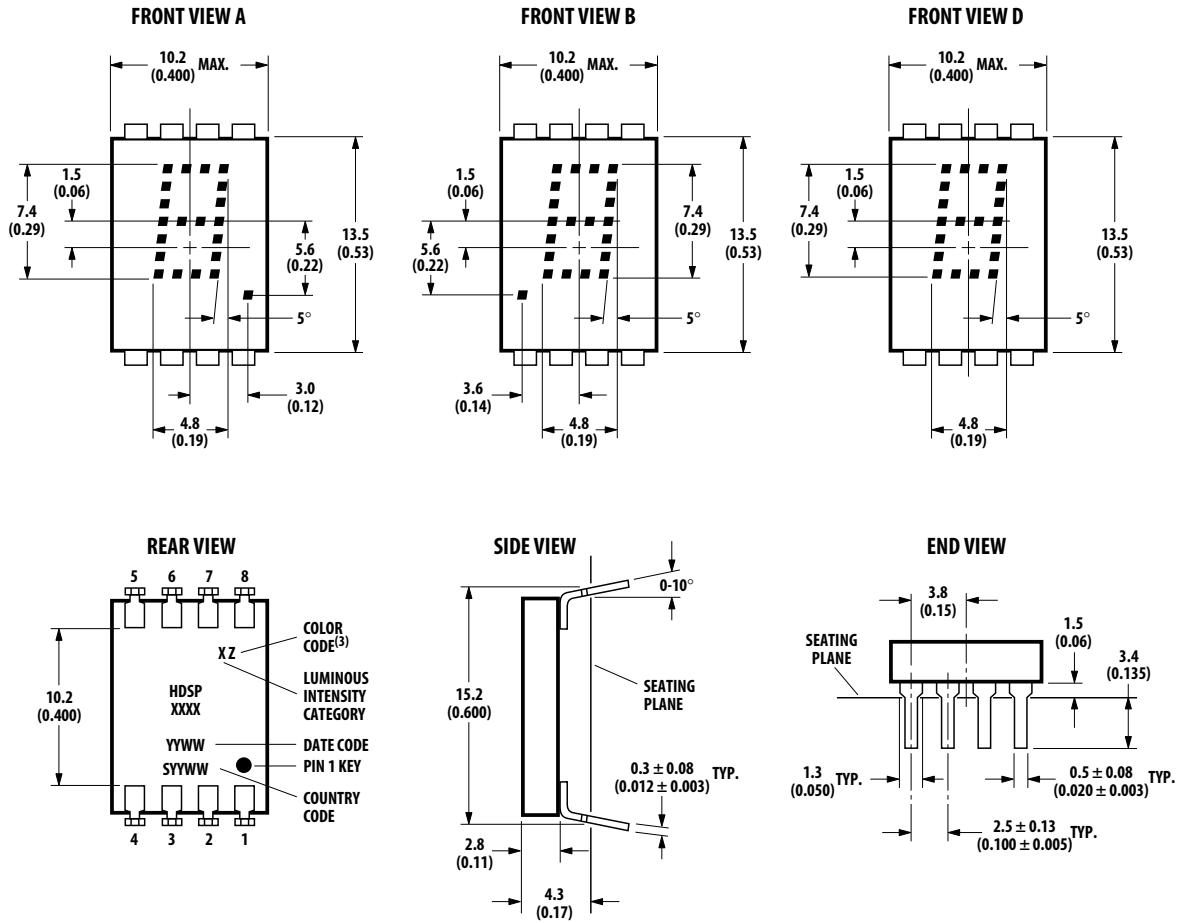

PIN	FUNCTION	
	NUMERIC	HEXADECIMAL
1	Input 2	Input 2
2	Input 4	Input 4
3	Input 8	Input 8
4	Decimal Point	Blanking Control
5	Latch Enable	Latch Enable
6	Ground	Ground
7	V _{CC}	V _{CC}
8	Input 1	Input 1

NOTES:

1. DIMENSIONS IN MILLIMETERS AND (INCHES).
2. UNLESS OTHERWISE SPECIFIED, THE TOLERANCE ON ALL DIMENSIONS IS ± 0.38 mm (± 0.015 INCH).
3. DIGIT CENTER LINE IS ± 0.25 mm (± 0.01 INCH) FROM PACKAGE CENTER LINE.
4. COLOR CODE FOR HDSP-088X/-098X SERIES.

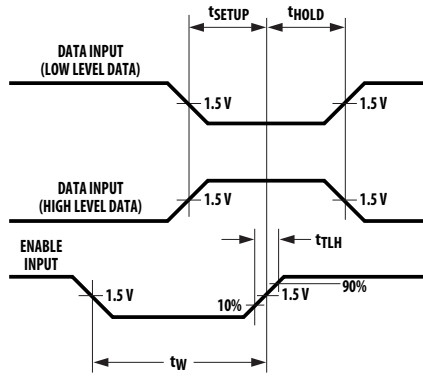

Figure 1. Timing diagram.

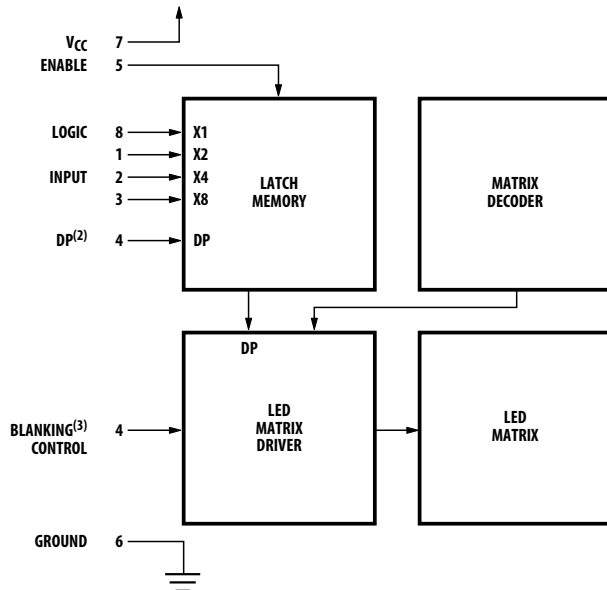

Figure 2. Block diagram.

TRUTH TABLE					
BCD DATA ^[1]				NUMERIC	HEXADECIMAL
X ₈	X ₄	X ₂	X ₁		
L	L	L	L	0	0
L	L	L	H	1	1
L	L	H	L	2	2
L	L	H	H	3	3
L	H	L	L	4	4
L	H	L	H	5	5
L	H	H	L	6	6
L	H	H	H	7	7
H	L	L	L	8	8
H	L	L	H	9	9
H	L	H	L	A	A
H	L	H	H	(BLANK)	B
H	H	L	L	(BLANK)	C
H	H	L	H	...	D
H	H	H	L	(BLANK)	E
H	H	H	H	(BLANK)	F
DECIMAL PT. ^[2]				ON	V _{DP} = L
				OFF	V _{DP} = H
ENABLE ^[1]				LOAD DATA	V _E = L
				LATCH DATA	V _E = H
BLANKING ^[3]				DISPLAY-ON	V _B = L
				DISPLAY-OFF	V _B = H

NOTES:

1. H = LOGIC HIGH; L = LOGIC LOW. WITH THE ENABLE INPUT AT LOGIC HIGH, CHANGES IN BCD INPUT LOGIC LEVELS HAVE NO EFFECT UPON DISPLAY MEMORY, DISPLAYED CHARACTER, OR DP.
2. THE DECIMAL POINT INPUT, DP, PERTAINS ONLY TO THE NUMERIC DISPLAYS.
3. THE BLANKING CONTROL INPUT, B, PERTAINS ONLY TO THE HEXADECIMAL DISPLAYS. BLANKING INPUT HAS NO EFFECT UPON DISPLAY MEMORY.

Absolute Maximum Ratings

Description	Symbol	Min.	Max.	Unit
Storage Temperature, Ambient	T_S	-65	+125	°C
HDSP-078x/-079x/-088x				
HDSP-098x		-55	+100	
Operating Temperature, Ambient ^[1]	T_A	-55	+100	°C
Supply Voltage ^[2]	V_{CC}	-0.5	+7.0	V
Voltage Applied to Input Logic, dp and Enable Pins	V_I, V_{DP}, V_E	-0.5	V_{CC}	V
Voltage Applied to Blanking Input ^[2]	V_R	-0.5	V_{CC}	V
Soldering Temperature [1.59 mm (0.063 inch) Below Body]				
Solder Dipping, max 5 seconds			260	°C
Wave Soldering, max. 3 seconds			250	

Recommended Operating Conditions

Description	Symbol	Min.	Nom.	Max.	Unit
Supply Voltage ^[2]	V_{CC}	4.5	5.0	5.5	V
Operating Temperature, Ambient ^[1]	T_A	-55		+100	°C
Enable Pulse Width	t_W	100			nsec
Time Data Must Be Held Before Positive Transition of Enable Line	t_{SETUP}	50			nsec
Time Data Must Be Held After Positive Transition of Enable Line	t_{HOLD}	50			nsec
Enable Pulse Rise Time	t_{TLH}			1.0	msec

Optical Characteristics at $T_A = 25^\circ\text{C}$, $V_{CC} = 5.0\text{V}$

Device	Description	Symbol	Min.	Typ.	Max.	Unit
HDSP-078x Series	Luminous Intensity per LED (Digit Average) ^[3,4]	I_V	65	140		μcd
	Peak Wavelength	λ_{PEAK}		635		nm
	Dominant Wavelength ^[5]	λ_d		626		nm
HDSP-079x Series	Luminous Intensity per LED (Digit Average) ^[3,4]	I_V	260	620		μcd
	Peak Wavelength	I_{PEAK}		635		nm
	Dominant Wavelength ^[5]	λ_d		626		nm
HDSP-088x Series	Luminous Intensity per LED (Digit Average) ^[3,4]	λ_V	215	490		μcd
	Peak Wavelength	λ_{PEAK}		583		nm
	Dominant Wavelength ^[5,6]	λ_d		585		nm
HDSP-098x Series	Luminous Intensity per LED (Digit Average) ^[3,4]	I_V	298	1100		μcd
	Peak Wavelength	λ_{PEAK}		568		nm
	Dominant Wavelength	λ_d		574		nm

Notes:

- The nominal thermal resistance of a display mounted in a socket that is soldered onto a printed circuit board is $R_{\theta_{JA}} = 50^\circ\text{C}/\text{W}/\text{device}$. The device package thermal resistance is $R_{\theta_{J-PIN}} = 15^\circ\text{C}/\text{W}/\text{device}$. The thermal resistance device pin-to-ambient through the PC board should not exceed $35^\circ\text{C}/\text{W}/\text{device}$ for operation up to $T_A = +100^\circ\text{C}$.
- Voltage values are with respect to device ground, pin 6.
- These displays are categorized for luminous intensity with the intensity category designated by a letter code located on the back of the display package. Case temperature of the device immediately prior to the light measurement is equal to 25°C .

Electrical/Optical Characteristics

$T_A = -55^\circ\text{C}$ to $+100^\circ\text{C}$

Description		Symbol	Test Conditions	Min.	Typ. ^[7]	Max.	Unit
Supply	HDSP-078x Series	I_{CC}	$V_{CC} = 5.5\text{ V}$ Characters "5." or "B" displayed		78	105	mA
Current	HDSP-079x/-088x/-098x Series				120	175	
Power	HDSP-078x Series	P_T	$V_{CC} = 5.5\text{ V}$ Characters "5." or "B" displayed		390	573	mW
Dissipation	HDSP-079x/-088x/-098x Series				690	963	
Logic, Enable and Blanking Low-Level Input Voltage		V_{IL}	$V_{CC} = 4.5\text{ V}$			0.8	V
Logic, Enable High-Level Input Voltage		V_{IH}		2.0			V
Blanking High-Voltage; Display Blanked		V_{BH}		2.3			V
Logic and Enable Low-Level Input Current		I_{IL}	$V_{CC} = 5.5\text{ V}$			-1.6	mA
Blanking Low-Level Input Current		I_{BL}	$V_{IL} = 0.4\text{ V}$			-10	μA
Logic, Enable and Blanking High-Level Input Current		I_{IH}	$V_{CC} = 5.5\text{ V}$ $V_{IH} = 2.4\text{ V}$			+40	μA
Weight					1.0		gm
Leak Rate						5×10^{-8}	cc/sec

Notes:

4. The luminous intensity at a specific operating ambient temperature, $I_V(T_A)$, may be approximated from the following exponential equation:
 $I_V(T_A) = I_V(25^\circ\text{C}) e^{[k(T_A - 25^\circ\text{C})]}$.

Device	K
HDSP-078 Series	-0.0131/ $^\circ\text{C}$
HDSP-079x Series	
HDSP-088x Series	-0.0112/ $^\circ\text{C}$
HDSP-098x Series	-0.0104/ $^\circ\text{C}$

5. The dominant wavelength, λ_d , is derived from the CIE chromaticity diagram and represents the single wavelength which defines the color of the device.
6. The HDSP-088X and HDSP-098X series devices are categorized as to dominant wavelength with the category designated by a number on the back of the display package.
7. All typical values at $V_{CC} = 5.0\text{ V}$ and $T_A = 25^\circ\text{C}$.

Operational Considerations

Electrical

These devices use a modified 4x7 dot matrix of light emitting diodes to display decimal/hexadecimal numeric information. The high efficiency red and yellow displays use GaAsP/GaP LEDs and the high performance green displays use GaP/GaP LEDs. The LEDs are driven by constant current drivers, BCD information is accepted by the display memory when the enable line is at logic low and the data is latched when the enable is at logic high. Using the enable pulse width and data setup and hold times listed in the Recommended Operating Conditions allows data to be clocked into an array of displays at a 6.7 MHz rate.

The decimal point input is active low true and this data is latched into the display memory in the same fashion as the BCD data. The decimal point LED is driven by the on-board IC.

The blanking control input on the hexadecimal displays blanks (turns off) the displayed information without disturbing the contents of display memory. The display is blanked at a minimum threshold level of 2.0 volts. When blanked, the display standby power is nominally 250 mW at $T_A = 25^\circ\text{C}$.

The ESD susceptibility of the IC devices is Class A of MIL-STD-883 or Class 2 of DOD-STD-1686 and DOD-HDBK-263.

Mechanical

These displays are hermetically sealed for use in environments that require a high reliability device. These displays are designed and tested to meet a helium leak rate of 5×10^{-8} cc/sec.

These displays may be mounted by soldering directly to a printed circuit board or insertion into a socket. The lead-to-lead pin spacing is 2.54 mm (0.100 inch) and the lead row spacing is 15.24 mm (0.600 inch). These displays may be end stacked with 2.54 mm (0.100 inch) spacing between outside pins of adjacent displays. Sockets such as Augat 324-AG2D (3 digits) or Augat 508-AG8D (one digit, right angle mounting) may be used.

The primary thermal path for power dissipation is through the device leads. Therefore, to insure reliable operation up to an ambient temperature of +100°C, it is important to maintain a base-to-ambient thermal resistance of less than 35°C watt/device as measured on top of display pin 3.

For further information on soldering and post solder cleaning, see Application Note 1027, *Soldering LED Components*.

Preconditioning

These displays are 100% preconditioned by 24 hour storage at 125°C, at 100°C for the HDSP-098x Series.

Contrast Enhancement

These display devices are designed to provide an optimum ON/OFF contrast when placed behind an appropriate contrast enhancement filter. For further information on contrast enhancement, see Application Note 1015, *Contrast Enhancement for LED Displays*.

Over Range Display

The over range devices display “±1” and decimal point. The character height and package configuration are the same as the numeric and hexadecimal devices. Character selection is obtained via external switching transistors and current limiting resistors.

Absolute Maximum Ratings

Description	Symbol	Min	Max	Unit
Storage Temperature, Ambient	T _S	-65	+125	°C
Operating Temperature, Ambient	T _A	-55	+100	°C
Forward Current, Each LED	I _F		10	mA
Reverse Voltage, Each LED	V _R		5	V

Package Dimensions

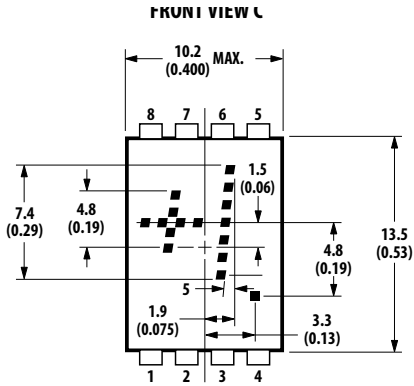

PIN	FUNCTION
1	Plus
2	Numeral One
3	Numeral One
4	DP
5	Open
6	Open
7	V _{CC}
8	Minus/Plus

Character	Pin			
	1	2,3	4	8
+	1	X	X	1
-	0	X	X	1
1	X	1	X	X
Decimal Point	X	X	1	X
Blank	0	0	0	0

NOTE: DIMENSIONS IN MILLIMETERS AND (INCHES).

Notes:

0: Line switching transistor in Figure 7 cutoff.

1: Line switching transistor in Figure 7 saturated.

X: 'don't care.'

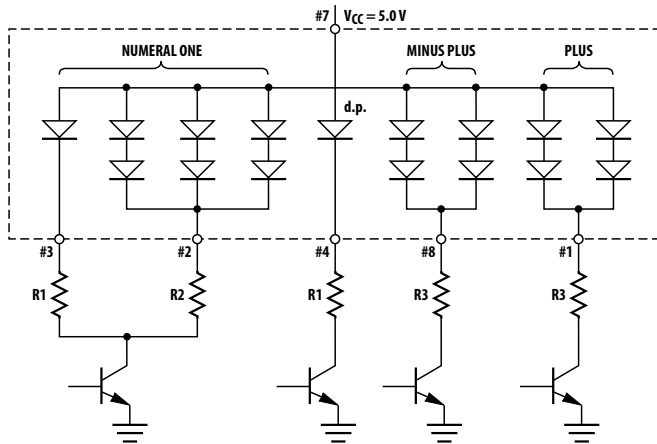

Figure 3. Typical driving circuit.

Luminous Intensity per LED

(Digit Average) at T_A = 25°C

Device	Test Conditions	Min.	Typ.	Units
HDSP-0783	I _F = 2.8 mA	65	140	μcd
	I _F = 8 mA		620	μcd
HDSP-0883	I _F = 8 mA	215	490	μcd
HDSP-0983	I _F = 8 mA	298	1100	μcd

Recommended Operating Conditions

V_{CC} = 5.0 V

Device		Forward Current Per LED, mA	Resistor Value		
			R ₁	R ₂	R ₃
HDSP-0783	Low Power	2.8	1300	200	300
	High Brightness	8	360	47	68
HDSP-0883		8	360	36	56
HDSP-0983		8	360	30	43

Electrical Characteristics

T_A = -55°C to +100°C

Device	Description	Symbol	Test Conditions	Min.	Typ.	Max.	Unit
HDSP-0783	Power Dissipation (All LEDs Illuminated)	P _T	I _F = 2.8 mA		72		mW
			I _F = 8 mA		224	282	
	Forward Voltage per LED	V _F	I _F = 2.8 mA		1.6		V
			I _F = 8 mA		1.75	2.2	
HDSP-0883	Power Dissipation (All LEDs Illuminated)	P _T	I _F = 8 mA		237	282	mW
	Forward Voltage per LED	V _F			1.90	2.2	V
HDSP-0983	Power Dissipation (All LEDs Illuminated)	P _T	I _F = 8 mA		243	282	mW
	Forward Voltage per LED	V _F			1.85	2.2	V

Intensity Bin Limits for HDSP-078x Series

Bin Category	Min. (mcd)	Max. (mcd)	Condition
A	0.065	0.102	Luminous Intensity per LED. V _{DD} @ 5.0 V
B	0.085	0.138	
C	0.114	0.200	
D	0.165	0.300	
E	0.260	0.488	
F	0.403	0.756	
G	0.625	1.172	

Intensity Bin Limits for HDSP-079x Series

Bin Category	Min. (mcd)	Max. (mcd)	Condition
E	0.260	0.488	Luminous Intensity per LED. V _{DD} @ 5.0 V
F	0.403	0.756	
G	0.625	1.172	
H	0.969	1.820	

Intensity Bin Limits for HDSP-088x Series

Bin Category	Min. (mcd)	Max. (mcd)	Condition
A	0.22	0.34	Luminous Intensity per LED. V _{DD} @ 5.0 V
B	0.28	0.46	
C	0.38	0.66	
D	0.55	0.99	
E	0.82	1.54	
F	1.27	2.39	

Intensity Bin Limits for HDSP-098x Series

Bin Category	Min. (mcd)	Max. (mcd)	Condition
C	0.30	0.52	Luminous Intensity per LED. V _{DD} @ 5.0 V
D	0.43	0.79	
E	0.65	1.18	
F	0.97	1.76	
G	1.45	2.63	

Color Bin Limits

(Dominant Wavelength)

Color	Bin	Intensity Range (nm)	
		Min.	Max.
Yellow	1	581.50	585.00
	2	584.00	587.50
	3	586.50	590.00
Green	1	570.00	574.00
	2	573.00	577.00
	3	576.00	580.00

Note:

Bin categories are established for classification of products. Products may not be available in all bin categories. Please consult your local Avago Technologies representative.

For product information and a complete list of distributors, please go to our website: www.avagotech.com



Компания «ЭлектроПласт» предлагает заключение долгосрочных отношений при поставках импортных электронных компонентов на взаимовыгодных условиях!

Наши преимущества:

- Оперативные поставки широкого спектра электронных компонентов отечественного и импортного производства напрямую от производителей и с крупнейших мировых складов;
- Поставка более 17-ти миллионов наименований электронных компонентов;
- Поставка сложных, дефицитных, либо снятых с производства позиций;
- Оперативные сроки поставки под заказ (от 5 рабочих дней);
- Экспресс доставка в любую точку России;
- Техническая поддержка проекта, помощь в подборе аналогов, поставка прототипов;
- Система менеджмента качества сертифицирована по Международному стандарту ISO 9001;
- Лицензия ФСБ на осуществление работ с использованием сведений, составляющих государственную тайну;
- Поставка специализированных компонентов (Xilinx, Altera, Analog Devices, Intersil, Interpoint, Microsemi, Aeroflex, Peregrine, Syfer, Eurofarad, Texas Instrument, Miteq, Cobham, E2V, MA-COM, Hittite, Mini-Circuits, General Dynamics и др.);

Помимо этого, одним из направлений компании «ЭлектроПласт» является направление «Источники питания». Мы предлагаем Вам помощь Конструкторского отдела:

- Подбор оптимального решения, техническое обоснование при выборе компонента;
- Подбор аналогов;
- Консультации по применению компонента;
- Поставка образцов и прототипов;
- Техническая поддержка проекта;
- Защита от снятия компонента с производства.



Как с нами связаться

Телефон: 8 (812) 309 58 32 (многоканальный)

Факс: 8 (812) 320-02-42

Электронная почта: org@eplast1.ru

Адрес: 198099, г. Санкт-Петербург, ул. Калинина, дом 2, корпус 4, литера А.