

R41Z Module for Thread and Bluetooth 4.2 LE

The **R41Z Module** from Rigado is a highly-integrated, ultra-low power module that enables Bluetooth Low Energy and IEEE 802.15.4 connectivity based on the Kinetis KW41Z SoC from NXP Semiconductors. With an ARM® Cortex™ M0+ processor, embedded 2.4GHz transceiver supporting FSK/GFSK and O-QPSK modulations, and integrated antenna, the **R41Z** provides a complete RF solution with no additional RF design allowing faster time to market. Equipped with the ability to concurrently communicate over Bluetooth and Thread connections, the R41Z offers an unprecedented level of connectivity in a single module. With an internal DC-DC Converter and a wide supply voltage range of 0.9V to 4.2V, the **R41Z** can be directly powered by sources ranging from single alkaline cells to lithium polymer batteries.



1. Features

- Based on the NXP Kinetis KW41Z SoC
- Complete RF solution with integrated antenna
- Integrated DC-DC converter
- Arm® Cortex™-M0+ 32-bit processor
- Serial Wire Debug
- Over-the-Air (OTA) firmware updates
- 512kB embedded flash memory
- 128kb RAM
- 25 GPIO, 2 dedicated analog pins
- 16-bit/500KSPS ADC
- 12-bit DAC
- -40°C to +105°C Temperature Range
- Rigado Software Suite
- 16 Capacitive Touch Sensing Inputs
- Two SPI Master/Slave (12Mbps)
- Two I²C Master/Slave
- UART (w/ CTS/RTS and DMA)
- Low power comparator
- Temperature sensor
- Infrared communication interface
- Nine low power modes
- True Random Number Generator
- 128-bit AES HW encryption
- 32bit Real-Time Clock (RTC)
- Wi-Fi coexistence support
- Dimensions: 10.6 x 16.2 x 2.1mm
- FCC: 2AA9B07
- IC: 12208A-07
- Japan: R210-109448

2. Applications

- Home/Office/Hotel Automation
- Low-Power Sensor Networks
- Home Appliances
- Lighting Products
- Climate Control
- Environmental Monitoring
- Home Health Care
- Safety and Security
- Access Control
- Smart Energy Management

3. Ordering Information

Email modules@rigado.com for quotes and ordering, or visit www.rigado.com/R41Z

Part Number	Description
R41Z-TA-R	R41Z-TA module, Rev A, Tape & Reel, 1000 piece multiples
R41Z-TA-EVAL	R41Z-TA Evaluation Kit with OpenSDA programmer

Table 1 - Ordering Part Numbers

4. Block Diagram

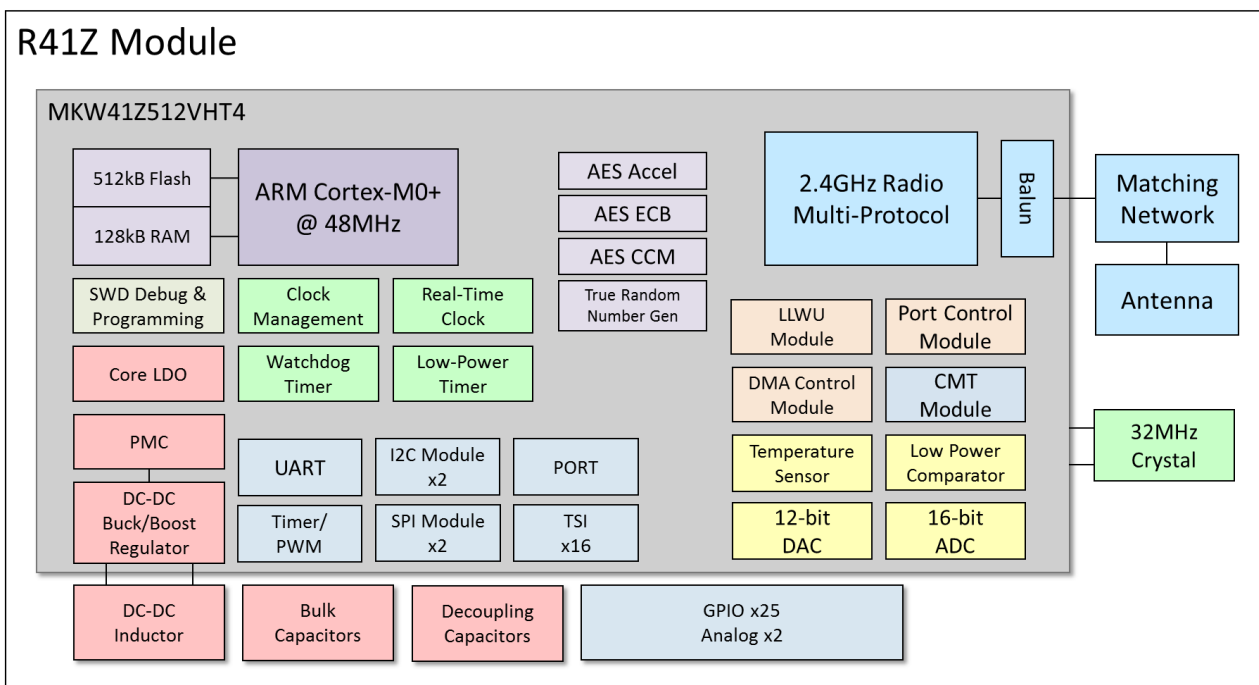

Figure 1 - Block Diagram

Table of Contents

1.	FEATURES	1
2.	APPLICATIONS.....	1
3.	ORDERING INFORMATION	2
4.	BLOCK DIAGRAM.....	2
5.	QUICK SPECIFICATIONS	7
6.	PIN DESCRIPTIONS AND SIGNAL ROUTING	8
6.1	R41Z PIN DESCRIPTIONS	8
6.2	GPIO AND LLWU SIGNALS	10
6.3	UART SIGNALS.....	11
6.4	SPI SIGNALS.....	11
6.5	I2C SIGNALS	11
6.6	TOUCH SENSING INPUT (TSI) SIGNALS	12
6.7	TIMER/PWM MODULE (TPM) SIGNALS	12
6.8	RADIO SIGNALS.....	13
6.8.1	Wi-Fi/BLE COEXISTENCE SIGNALS	13
6.8.2	DIRECT TEST MODE (DTM) SIGNALS.....	13
6.8.3	802.15.4 BIT STREAMING MODE (BSM) SIGNALS	13
6.9	CARRIER MODULATOR TIMER (CMT) SIGNAL.....	13
6.10	RTC AND CLOCK SIGNALS.....	14
6.11	SINGLE WIRE DEBUG (SWD) AND RESET SIGNALS	14
6.12	ANALOG SIGNALS	14
7.	ELECTRICAL DESCRIPTION.....	15
7.1	ABSOLUTE MAXIMUM RATINGS	15
7.2	OPERATING CONDITIONS.....	15
7.3	DCDC CONVERTER OPERATION.....	15
7.3.1	DCDC BYPASS MODE	16
7.3.2	DCDC BUCK MODE.....	17
7.3.3	DCDC BOOST MODE.....	18
7.4	GENERAL PURPOSE I/O AND PORTS	20
7.5	ANALOG I/O AND VREF	21
7.5.1	ANALOG SIGNALS	21
7.5.2	VDDA AND VREF.....	21
7.6	MODULE RESET	21
7.7	DEBUG AND PROGRAMMING.....	21
7.8	CLOCKS	22
7.8.1	GENERAL PARAMETERS	22
8.	FIRMWARE.....	23
8.1	FACTORY IMAGE.....	23
8.1.1	FIRMWARE VERSION '00'	23
8.2	MAC ADDRESS INFO.....	23
9.	MECHANICAL DATA.....	24
9.1	PACKAGE DIMENSIONS	24
9.2	RECOMMENDED PCB FOOTPRINT	25
10.	MODULE MARKING.....	25
11.	RF DESIGN NOTES.....	26
11.1	RECOMMENDED RF LAYOUT AND GROUND PLANE	26
11.2	MECHANICAL ENCLOSURE	26
11.3	ANTENNA PATTERNS	27
11.3.1	X-Y PLANE	27
11.3.2	Y-Z PLANE	28
11.3.3	Z-X PLANE	28
12.	EVALUATION BOARDS.....	29
13.	CUSTOM DEVELOPMENT.....	29
14.	BLUETOOTH QUALIFICATION.....	30
15.	REGULATORY STATEMENTS.....	30

15.1	FCC STATEMENT.....	30
15.2	FCC IMPORTANT NOTES:	30
15.3	IC STATEMENT:.....	32
15.4	IC IMPORTANT NOTES:	32
15.5	CE REGULATORY:	33
15.6	JAPAN (MIC)	33
15.7	AUSTRALIA / NEW ZEALAND	34
16.	SOLDER REFLOW TEMPERATURE-TIME PROFILE	35
16.1	MOISTURE SENSITIVITY LEVEL.....	35
17.	PACKAGING AND LABELING	36
17.1	CARRIER TAPE DIMENSION	36
17.2	REEL PACKAGING.....	36
17.3	PACKAGING LABEL	37
18.	CAUTIONS	37
19.	LIFE SUPPORT POLICY.....	38
20.	DOCUMENT HISTORY	38
21.	RELATED DOCUMENTS	38

Table of Figures

FIGURE 1 - BLOCK DIAGRAM	2
FIGURE 2 - R41Z PIN OUT (TOP VIEW)	8
FIGURE 3 - SCHEMATIC: DCDC BYPASS MODE EXAMPLE	16
FIGURE 4 - SCHEMATIC: DCDC BUCK MODE EXAMPLE	17
FIGURE 5 - SCHEMATIC: DCDC BUCK MODE PSWITCH EXAMPLE	18
FIGURE 6 - SCHEMATIC: DCDC BOOST MODE EXAMPLE	19
FIGURE 7 - PCB: BOOST MODE SUGGESTED LAYOUT	20
FIGURE 8 - SCHEMATIC: LOW FREQUENCY CRYSTAL	22
FIGURE 10 - R41Z MAC ADDRESS ON LABEL	23
FIGURE 11 - R41Z MODULE DIMENSIONS	24
FIGURE 12 - R41Z PAD LAYOUT (TOP VIEW)	25
FIGURE 13 - R41Z MODULE MARKING - REVA	25
FIGURE 14 - R41Z RF EXAMPLE BASED ON EVAL BOARD	26
FIGURE 15 - X-Y-Z ANTENNA ORIENTATION	27
FIGURE 16 - X-Y PLANE ANTENNA PATTERN	27
FIGURE 17 - Y-Z ANTENNA PATTERN	28
FIGURE 18 - Z-X PLANE ANTENNA PATTERN	28
FIGURE 19 - R41Z EVALUATION BOARD	29
FIGURE 20 - REFLOW PROFILE FOR LEAD FREE SOLDER	35
FIGURE 21 - CARRIER TAPE DIMENSION	36
FIGURE 22 - REEL CARTONS	36
FIGURE 23 - PACKAGING LABEL	37

Specification Tables

TABLE 1 - ORDERING PART NUMBERS	2
TABLE 2 - QUICK SPECIFICATIONS	7
TABLE 3 - R41Z PIN DESCRIPTIONS	9
TABLE 4 - GPIO AND LLWU SIGNAL MAP	10
TABLE 5 - UART SIGNAL MAP	11
TABLE 6 - SPI SIGNAL MAP	11
TABLE 7 - I2C SIGNAL MAP	11
TABLE 8 - TSI SIGNAL MAP	12
TABLE 9 - TPM SIGNAL MAP	12
TABLE 10 – WI-FI/BLE COEXISTENCE SIGNAL MAP	13
TABLE 11 - DTM SIGNALS	13
TABLE 12 - BSM SIGNAL MAP	13
TABLE 13 - CMT SIGNAL MAP	13
TABLE 14 - RTC AND CLOCK SIGNAL MAP	14
TABLE 15 - SWD AND RESET SIGNALS	14
TABLE 16 ANALOG SIGNALS	14
TABLE 17 - ABSOLUTE MAXIMUM RATINGS	15
TABLE 18 - OPERATING CONDITIONS	15
TABLE 19 - BYPASS MODE PIN CONNECTIONS.....	16
TABLE 20 - DCDC BUCK MODE PIN CONNECTIONS	17
TABLE 21 - DCDC BOOST MODE PIN CONNECTIONS.....	18
TABLE 22 - GPIO PROPERTIES	21
TABLE 23 - ANALOG PROPERTIES	21
TABLE 24 – LOW FREQUENCY CRYSTAL RECOMMENDED SPECIFICATIONS	22

5. Quick Specifications

Bluetooth		
Version	4.2	
Security	AES-128	
LE Connections	2	
Thread (IEEE 802.15.4)		
Version	1.1	
Stack	NXP KW41Z Thread stack	
Security	AES-128	
Node Types	Router Eligible, End Device, REED	
Radio		
Frequency	2.360GHz to 2.483GHz	
Modulations	GFSK @ 1Mbps, OQPSK @ 250kbps	
Transmit power	+3.5dbm	
Receiver sensitivity	-95dBm (BLE), -100dBm (IEEE 802.15.4)	
Antenna	Integrated	
Current Consumptions		
TX only @ 0dBm, bypass mode	14.7 mA	
TX only @ 0dBm, DCDC enabled, 3.6V Vin	6.1mA	
RX only, bypass mode	16.2mA	
RX only, DCDC enabled, 3.6V Vin	6.7mA	
Normal Run CPU @ 48MHz @ 3.0V, DCDC enabled	4.8mA	
Very-Low-Power Run CPU @ 4MHz @ 3.0V, DCDC enabled	137µA	
Very-Low-Leakage Stop 3 (RAM retained) @ 3.0V @ 25°C, DCDC enabled	1.8 µA	
Very-Low-Leakage Stop 0 @ 3.0V @ 25°C, bypass mode	182 nA	
Dimensions		
Length	16.2 mm ± 0.3mm	
Width	10.6 mm ± 0.3mm	
Height	2.1 mm ± 0.1mm	
Hardware		
Interfaces	SPI Master/Slave x2 UART x1 Touch Sense Interface x16	Two-Wire Mast/Slave (I2C) x2 GPIO x25 Analog input x6
Power Supply	Boost mode: 0.9V to 1.8V, 1.1V required to startup Bypass mode: 1.71V to 3.6V Buck mode: 1.8V to 4.2V, 2.1V required to startup	
Temperature Range	-40 to +105 °C	
Certifications		
FCC	FCC part 15 modular certification ID: 2AA9B07	
IC	Industry Canada RSS-210 modular certification IC: 12208A-07	
CE	EN 60950-1: 2011-01 EN 301 489-1 V1.9.2 & EN 301 489-17 V2.2.1 EN 300 328 V1.9.1	3.1 (a): Health and Safety of the User 3.1 (b): Electromagnetic Compatibility 3.2: Effective use of spectrum allocated
Japan (MIC)	Ministry of Internal Affairs and Communications (MIC) of Japan pursuant to the Radio Act of Japan - Certificate Number: R210-109448	
Australia / New Zealand	AS/NZS 4268 :2012+AMDT 1:2013, Radio equipment and systems – Short range devices	
Bluetooth	Pending	
Thread	Pending	

Table 2 - Quick Specifications

6. Pin Descriptions and Signal Routing

6.1 R41Z Pin Descriptions

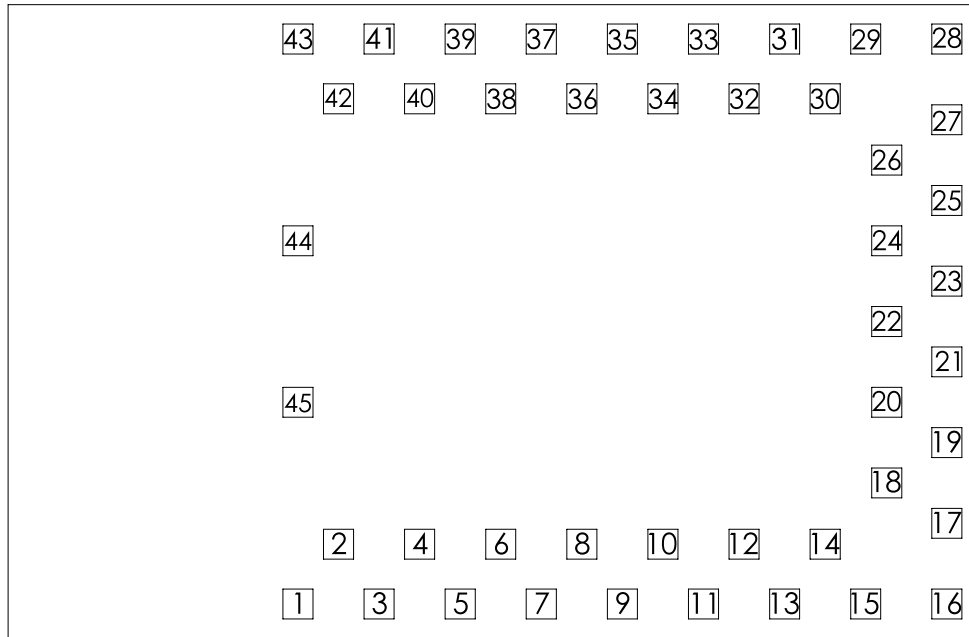

Figure 2 - R41Z Pin out (Top View)

GPIO/Analog				
Pin	Name	Direction	Description	Default State at POR
2	PTC1	In/Out	GPIO	Disabled
3	PTC2	In/Out	GPIO	Disabled
4	PTC3	In/Out	GPIO	Disabled
5	PTC4	In/Out	GPIO	Disabled
6	PTC5	In/Out	GPIO	Disabled
7	PTC6	In/Out	GPIO	Disabled
8	PTC7	In/Out	GPIO	Disabled
10	PTC16	In/Out	GPIO	Disabled
11	PTC17	In/Out	GPIO	Disabled
12	PTC18	In/Out	GPIO	Disabled
13	PTC19	In/Out	GPIO	Disabled
14	PTA0	In/Out	GPIO	SWDIO, Pullup EN
15	PTA1	In/Out	GPIO	SWCLK, Pulldown EN
17	PTA2	In/Out	GPIO	Reset, Pullup EN
18	PTA16	In/Out	GPIO	Disabled
19	PTA17	In/Out	GPIO	Disabled
20	PTA18	In/Out	GPIO	Disabled
21	PTA19	In/Out	GPIO	Disabled

Pin	Name	Direction	Description	Default State at POR
30	PTB0	In/Out	GPIO	XTAL_OUT_EN ¹
31	PTB1	In/Out	GPIO	Disabled
32	PTB2	In/Out	GPIO	Disabled
33	PTB3	In/Out	GPIO	Disabled
34	PTB16	In/Out	GPIO	EXTAL32K
36	PTB17	In/Out	GPIO	XTAL32K
37	PTB18	In/Out	GPIO	Non Maskable Interrupt Req.
38	ADC0_P	In	ADC/Comparator input	N/A
39	ADC0_N	In	ADC/Comparator input	N/A
Reference Signals				
Pin	Name	Direction	Description	
40	XTAL_OUT	Out	32MHz Clock output	
41	VREF	In/Out	Analog reference voltage. Internally or externally sourced	
42	VDDA	Power	Analog supply. Internally sourced ²	
Power				
Pin	Name	Direction	Description	
22	PSWITCH	Input	DCDC start signal ³	
23	DCDC_CFG	Input	DCDC mode ³	
25	VCC	Power	DCDC input ³	
26	DCDC_LP	Power	DCDC signal ³	
27	V1P8	Power	DCDC IO and peripheral voltage ³	
29	V1P5	Power	DCDC RF supply ³	
1, 9, 16, 24, 28, 35, 43, 44, 45	GND	Power	Electrical Ground	
Note 1: See e10224 in NXP KW41Z errata				
Note 2: VDDA is connected to V1P8 through a power filtering circuit on the module				
Note 3: See the DCDC Converter Operation section for details on signal usage and DCDC modes				

Table 3 - R41Z Pin Descriptions

Note: Internal peripherals on the R41Z (such as UART and I2C) can be routed to multiple pin options using multiplexing. However, each pin can only be used with certain peripherals. See the following sections for details on which pins can be used for given functions.

Signal options for a pin are selected using a pin mux value. On many pins, there are multiple signals that are accessed with the same pin mux value. See the [NXP KW41Z Reference Manual](#) for details on configuring these functions.

6.2 GPIO and LLWU Signals

To use a Pin as GPIO or as a Low Leakage Wake Up source, pin mux ALT1 should be used. LLWU pins can be used to trigger interrupts that can bring the module out of Low Leakage sleep modes.

Signal	Direction	Description	Pin	Port	Mux Alt
PTC1	In/Out	GPIO	2	PTC1	ALT1
PTC2 / LLWU_P10	In/Out	GPIO, LLWU	3	PTC2	ALT1
PTC3 / LLWU_P11	In/Out	GPIO, LLWU	4	PTC3	ALT1
PTC4 / LLWU_P12	In/Out	GPIO, LLWU	5	PTC4	ALT1
PTC5 / LLWU_P13	In/Out	GPIO, LLWU	6	PTC5	ALT1
PTC6 / LLWU_P14	In/Out	GPIO, LLWU	7	PTC6	ALT1
PTC7 / LLWU_P15	In/Out	GPIO, LLWU	8	PTC7	ALT1
PTC16 / LLWU_P0	In/Out	GPIO, LLWU	10	PTC16	ALT1
PTC17 / LLWU_P1	In/Out	GPIO, LLWU	11	PTC17	ALT1
PTC18 / LLWU_P2	In/Out	GPIO, LLWU	12	PTC18	ALT1
PTC19 / LLWU_P3	In/Out	GPIO, LLWU	13	PTC19	ALT1
PTA0	In/Out	GPIO	14	PTA0	ALT1
PTA1	In/Out	GPIO	15	PTA1	ALT1
PTA2	In/Out	GPIO	17	PTA2	ALT1
PTA16 / LLWU_P4	In/Out	GPIO, LLWU	18	PTA16	ALT1
PTA17 / LLWU_P5	In/Out	GPIO, LLWU	19	PTA17	ALT1
PTA18 / LLWU_P6	In/Out	GPIO, LLWU	20	PTA18	ALT1
PTA19 / LLWU_P7	In/Out	GPIO, LLWU	21	PTA19	ALT1
PTB0 / LLWU_P8	In/Out	GPIO, LLWU	30	PTB0 ¹	ALT1
PTB1	In/Out	GPIO	31	PTB1	ALT1
PTB2	In/Out	GPIO	32	PTB2	ALT1
PTB3	In/Out	GPIO	33	PTB3	ALT1
PTB16	In/Out	GPIO	34	PTB16	ALT1
PTB17	In/Out	GPIO	36	PTB17	ALT1
PTB18	In/Out	GPIO	37	PTB18	ALT1

Note 1: See e10224 in [NXP KW41Z errata](#)

Table 4 - GPIO and LLWU Signal Map

6.3 UART Signals

Signal	Direction	Description	Pin	Port	Mux Alt
LPUART0_RX	In	UART Data Receiver	3	PTC2	ALT4
			7	PTC6	ALT4
			11	PTC17	ALT4
LPUART0_TX	Out	UART Data Transmit	4	PTC3	ALT4
			8	PTC7	ALT4
			12	PTC18	ALT4
LPUART0_CTS_b	In	UART Clear to Send	5	PTC4	ALT4
			13	PTC19	ALT4
LPUART0_RTS_b	Out	UART Request to Send	2	PTC1	ALT4
			6	PTC5	ALT4
			10	PTC16	ALT4

Table 5 - UART Signal Map

6.4 SPI Signals

Signal	Direction	Description	Pin	Port	Mux Alt
SPIO_SCK	In/Out	SPIO Clock	10	PTC16	ALT2
SPIO_SOUT	Out	SPIO Serial Out	11	PTC17	ALT2
SPIO_SIN	In	SPIO Serial In	12	PTC18	ALT2
SPIO_PCS0	In/Out	SPIO Chip Select / Slave Select 0	13	PTC19	ALT2
SPIO_PCS1	In/Out	SPIO Chip Select / Slave Select 1	14	PTA0	ALT2
SPIO_PCS2	In/Out	SPIO Chip Select / Slave Select 2	8	PTC7	ALT2
SPI1_SCK	In/Out	SPI1 Clock	20	PTA18	ALT2
SPI1_SOUT	Out	SPI1 Serial Out	18	PTA16	ALT2
SPI1_SIN	In	SPI1 Serial In	19	PTA17	ALT2
SPI1_PCS0	In/Out	SPI1 Chip Select / Slave Select 0	15	PTA1	ALT2
			21	PTA19	ALT2

Table 6 - SPI Signal Map

6.5 I2C Signals

Signal	Direction	Description	Pin	Port	Mux Alt
I2C0_SDA	In/Out	I2C0 Serial Data Line	2	PTC1	ALT3
			10	PTC16	ALT3
			31	PTB1	ALT3
I2C0_SCL	In/Out	I2C0 Serial Clock Line	13	PTC19	ALT3
			30	PTB0	ALT3
I2C1_SDA	In/Out	I2C1 Serial Data Line	4	PTC3	ALT3
			8	PTC7	ALT3
			12	PTC18	ALT3
			36	PTB17	ALT3
I2C1_SCL	In/Out	I2C1 Serial Clock Line	3	PTC2	ALT3
			7	PTC6	ALT3
			11	PTC17	ALT3
			34	PTB16	ALT3
			37	PTB18	ALT3

Table 7 - I2C Signal Map

6.6 Touch Sensing Input (TSI) Signals

TSI signals are the inputs used by the R41Z's capacitive touch sensing system. See [NXP Application Note AN3863](#) for electrical and PCB layout recommendations.

Signal	Direction	Description	Pin	Port	Mux Alt
TSIO_CH0	In	TSIO channel 0	5	PTC4	ALTO
TSIO_CH1	In	TSIO channel 1	6	PTC5	ALTO
TSIO_CH2	In	TSIO channel 2	7	PTC6	ALTO
TSIO_CH3	In	TSIO channel 3	8	PTC7	ALTO
TSIO_CH4	In	TSIO channel 4	10	PTC16	ALTO
TSIO_CH5	In	TSIO channel 5	11	PTC17	ALTO
TSIO_CH6	In	TSIO channel 6	12	PTC18	ALTO
TSIO_CH7	In	TSIO channel 7	13	PTC19	ALTO
TSIO_CH8	In	TSIO channel 8	14	PTA0	ALTO
TSIO_CH9	In	TSIO channel 9	15	PTA1	ALTO
TSIO_CH10	In	TSIO channel 10	18	PTA16	ALTO
TSIO_CH11	In	TSIO channel 11	19	PTA17	ALTO
TSIO_CH12	In	TSIO channel 12	20	PTA18	ALTO
TSIO_CH13	In	TSIO channel 13	21	PTA19	ALTO
TSIO_CH14	In	TSIO channel 14	3	PTC2	ALTO
TSIO_CH15	In	TSIO channel 15	4	PTC3	ALTO

Table 8 - TSI Signal Map

6.7 Timer/PWM Module (TPM) Signals

Signal	Direction	Description	Pin	Port	Mux Alt
TPM0_CH0	In/Out	TPM0 channel 0	18	PTA16	ALT5
			37	PTB18	ALT5
TPM0_CH1	In/Out	TPM0 channel 1	4	PTC3	ALT5
			30	PTB0	ALT5
TPM0_CH2	In/Out	TPM0 channel 2	2	PTC1	ALT5
			31	PTB1	ALT5
TPM0_CH3	In/Out	TPM0 channel 3	10	PTC16	ALT5
			17	PTA2	ALT5
TPM1_CH0	In/Out	TPM1 channel 0	5	PTC4	ALT5
			14	PTA0	ALT5
			32	PTB2	ALT5
TPM1_CH1	In/Out	TPM1 channel 1	6	PTC5	ALT5
			15	PTA1	ALT5
TPM2_CH0	In/Out	TPM2 channel 0	33	PTB3	ALT5
			7	PTC6	ALT5
TPM2_CH1	In/Out	TPM2 channel 1	20	PTA18	ALT5
			34	PTB16	ALT5
TPM2_CH1	In/Out	TPM2 channel 1	8	PTC7	ALT5
			21	PTA19	ALT5
TPM2_CH1	In/Out	TPM2 channel 1	36	PTB17	ALT5
			19	PTA17	ALT5
EXTRG_IN	In	TPM/ADC External Trigger signal	5	PTC4	ALT3

Table 9 - TPM Signal Map

6.8 Radio Signals

6.8.1 Wi-Fi/BLE Coexistence Signals

Signal	Direction	Description	Pin	Port	Mux Alt
BLE_RF_ACTIVE	Out	External radio disable signal	2	PTC1	ALT7
			13	PTC19	ALT7
RF_NOT_ALLOWED	In	R41Z radio disable signal	6	PTC5	ALT2
			32	PTB2	ALT2

Table 10 – Wi-Fi/BLE Coexistence Signal Map

6.8.2 Direct Test Mode (DTM) Signals

Signal	Direction	Description	Pin	Port	Mux Alt
DTM_RX	In	Direct Test Mode receive signal	3	PTC2	ALT7
			11	PTC17	ALT7
			31	PTB1	ALT2
DTM_TX	Out	Direct Test Mode transmit signal	4	PTC3	ALT7
			12	PTC18	ALT7
			32	PTB2	ALT3
RF_RESET	In	Radio reset signal	19	PTA17	ALT1

Table 11 - DTM Signals

6.8.3 802.15.4 Bit Streaming Mode (BSM) Signals

Signal	Direction	Description	Pin	Port	Mux Alt
BSM_DATA	In/Out	Bit Streaming Mode Data signal	5	PTC4	ALT7
			8	PTC7	ALT7
			12	PTC18	ALT5
BSM_CLK	Out	Bit Streaming Mode clock signal	6	PTC5	ALT7
			13	PTC19	ALT5
			36	PTB17	ALT7
BSM_FRAME	Out	Bit Streaming Mode Frame signal	7	PTC6	ALT7
			11	PTC17	ALT5

Table 12 - BSM Signal Map

6.9 Carrier Modulator Timer (CMT) Signal

Signal	Direction	Description	Pin	Port	Mux Alt
CMT_IRO	Out	Carrier Modulator Timer out signal	3	PTC2	ALT5
			30	PTB0	ALT7

Table 13 - CMT Signal Map

6.10 RTC and Clock Signals

Signal	Direction	Description	Pin	Port	Mux Alt
XTAL_OUT_EN ¹	In	EN input for XTAL_OUT (Pin 40)	7	PTC6	ALT1
			30	PTB0 ¹	ALT1
CLKOUT	Out	Internal clocks monitor	30	PTB0	ALT7
			33	PTB3	ALT4
RTC_CLKOUT	Out	RTC 1Hz clock signal	33	PTB3	ALT7
EXTAL32K	In	32kHz external clock/oscillator	34	PTB16	ALT0
XTAL32K	In	32kHz external clock	36	PTB17	ALT0

Note 1: See e10224 in [NXP KW41Z errata](#)

Table 14 - RTC and Clock Signal Map

6.11 Single Wire Debug (SWD) and Reset Signals

Signal	Direction	Description	Pin	Port	Mux Alt
SWD_DIO	In/Out	SWD data signal	14	PTA0	ALT7
SWD_CLK	In	SWD clock signal	15	PTA1	ALT7
RESET_b	In/Out	System reset signal, bidirectional	17	PTA2	ALT7

Table 15 - SWD and Reset Signals

6.12 Analog Signals

Signal	Direction	Description	Pin	Port	Mux Alt
CMPO_OUT	Out	Comparator 0 output	30	PTB0	ALT4
CMPO_IN0	In	Comparator 0 Single-ended input 0	38	-	-
CMPO_IN1	In	Comparator 0 Single-ended input 1	39	-	-
CMPO_IN2	In	Comparator 0 Single-ended input 2	37	PTB18	ALT0
CMPO_IN3	In	Comparator 0 Single-ended input 3	32	PTB2	ALT0
CMPO_IN4	In	Comparator 0 Single-ended input 4	33	PTB3	ALT0
CMPO_IN5	In	Comparator 0 Single-ended input 5	31	PTB1	ALT0
ADCO_SE0	In	ADC Channel 0 Single-ended input 0	31	PTB1	ALT0
ADCO_SE1	In	ADC Channel 0 Single-ended input 1	33	PTB3	ALT0
ADCO_SE2	In	ADC Channel 0 Single-ended input 2	32	PTB2	ALT0
ADCO_SE3	In	ADC Channel 0 Single-ended input 3	37	PTB18	ALT0
ADCO_SE4	In	ADC Channel 0 Single-ended input 4	21	PTA19	ALT0
ADCO_DPO	In	ADC Channel 0 Differential input positive	38	-	-
ADCO_DNO	In	ADC Channel 0 Differential input negative	39	-	-
DACO_OUT	Out	DAC Channel 0 Single-ended output	37	PTB18	ALT0

Table 16 Analog Signals

7. Electrical Description

7.1 Absolute Maximum Ratings

Symbol	Parameter	Condition	Min.	Max.	Unit
V _{cc_MAX}	Voltage on Supply Pin	DCDC Boost Mode	-0.3	1.8	V
		DCDC Bypass Mode	-0.3	3.6	V
		DCDC Buck Mode	-0.3	4.2	V
V _{1P8_MAX}	Voltage on V1P8 and GPIO	All DCDC modes	-0.3	3.6	V
V _{RF_MAX}	Voltage on V1P5	All DCDC modes	-0.3	3.6	V
T _S	Storage Temperature	-	-40	125	°C

Table 17 - Absolute Maximum Ratings

7.2 Operating Conditions

Symbol	Parameter	Condition	Min.	Typ.	Max.	Unit
V _{cc}	Voltage on Supply Pin	DCDC Boost Mode	0.9 ¹	1.5	1.8	V
		DCDC Bypass Mode	1.71	3.3	3.6	V
		DCDC Buck Mode	1.8 ²	3.3	4.2	V
V _{1P8}	Voltage on V1P8 and GPIO	All DCDC modes	1.45	3.3	3.6	V
V _{RF}	Voltage on V1P5	All DCDC modes	1.8	3.3	3.6	V
I _{1P8}	V1P8 output current	DCDC Buck Mode, 1.8Vout	-	-	45	mA
		DCDC Buck Mode, 3.0Vout	-	-	27	mA
		DCDC Boost Mode, 1.7Vin, 1.8 Vout	-	-	45	mA
		DCDC Boost Mode, 0.9Vin, 3.0Vout	-	-	10	mA
T _A	Ambient Temperature	-	-40	25	105	°C
Note 1: In Boost mode, a minimum of 1.1V is required to start the DCDC converter. Once started, the converter can operate at 0.9V						
Note 2: In Buck mode, a minimum of 2.1V is required to start the DCDC converter.						

Table 18 - Operating Conditions

7.3 DCDC Converter Operation

The R41Z module contains an integrated DCDC converter which allows for three modes of operation without additional components. When operating in DCDC Buck mode, power consumption from using the radio can be reduced compared to DCDC Bypass mode. DCDC Boost mode allows the use of a single alkaline or other low voltage source. While it is possible to switch between these modes in a single design, for example the R41Z Evaluation Board, it is not recommended to switch between modes while power is applied.

7.3.1 DCDC Bypass Mode

Mode	Pin	Name	Net Connection
Bypass	22	PSWITCH	Ground
	23	DCDC_CFG	1.71V - 3.6V Source IN
	25	VCC	1.71V - 3.6V Source IN
	26	DCDC_LP	No Connection
	27	V1P8	1.71V - 3.6V Source IN
	29	V1P5	1.45V - 3.6V Source IN

Table 19 - Bypass Mode Pin Connections

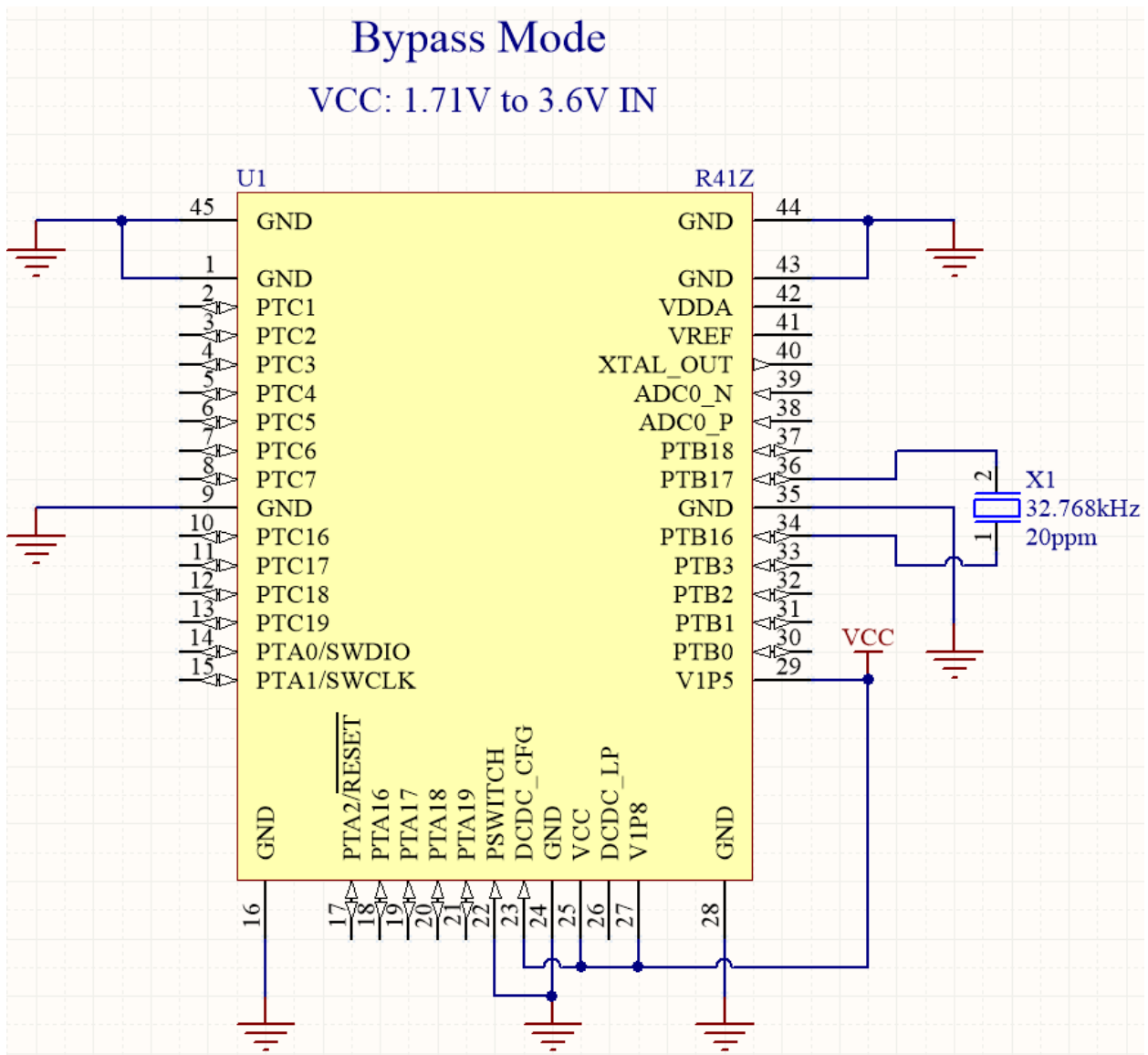

Figure 3 - Schematic: DCDC Bypass Mode Example

7.3.2 DCDC Buck Mode

Mode	Pin	Name	Net Connection
Buck	22	PSWITCH ¹	1.8V - 4.2V Source IN
	23	DCDC_CFG	1.8V - 4.2V Source IN
	25	VCC	1.8V - 4.2V Source IN
	26	DCDC_LP	No Connection
	27	V1P8	No Connection or 1.8V – 3.0V OUT ²
	29	V1P5	No Connection

Note 1: In Buck mode PSWITCH can inhibit the DCDC converter from starting when the source voltage is applied. When PSWITCH is connected to the source voltage, the DCDC converter will start. Once started, PSWITCH can be reconnected to GND without disrupting the DCDC converter's operation.

Note 2: V1P8 is the R41Z's IO voltage when the DCDC converter is running in either Buck or Boost mode. V1P8 can source a limited number of additional peripheral devices (sensors, LEDs, etc.) that connect directly to the R41Z's IO. In Buck mode, V1P8 cannot output a voltage greater than the source voltage

Table 20 - DCDC Buck Mode Pin Connections

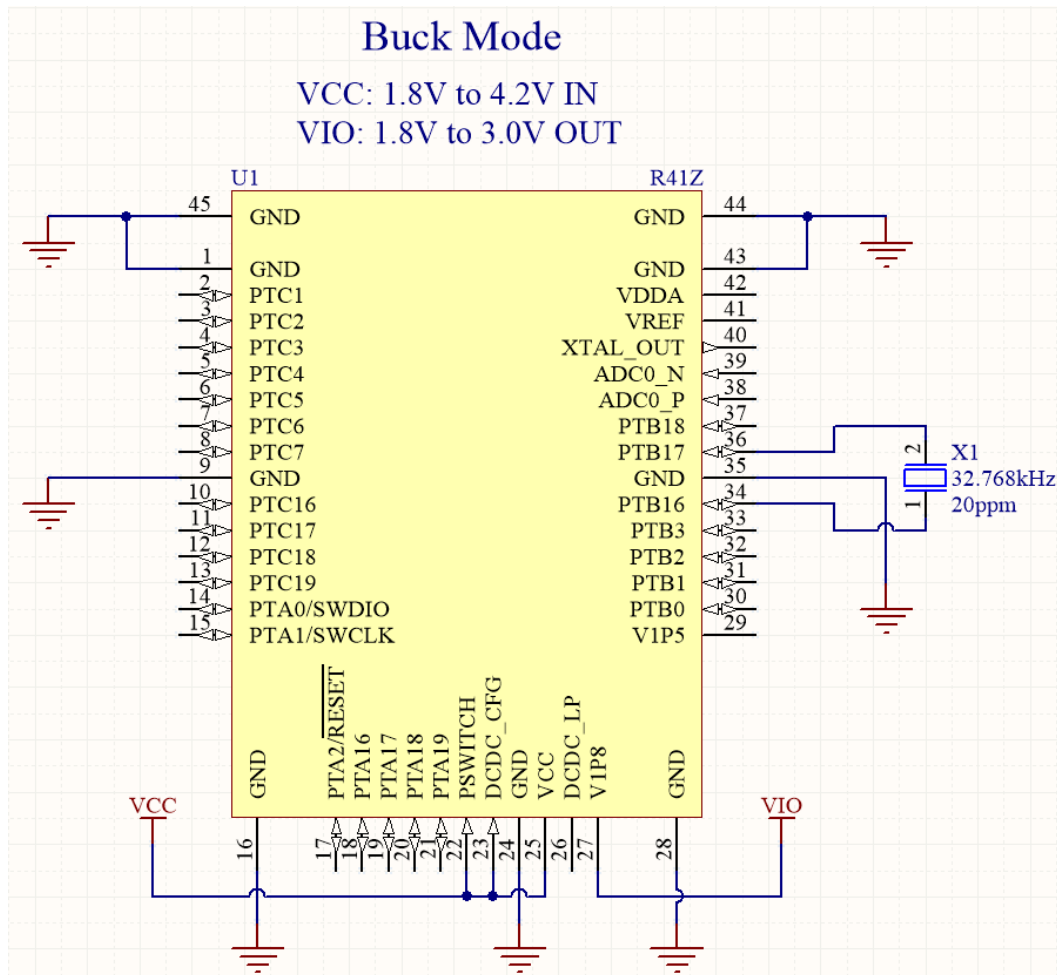

Figure 4 - Schematic: DCDC Buck Mode Example

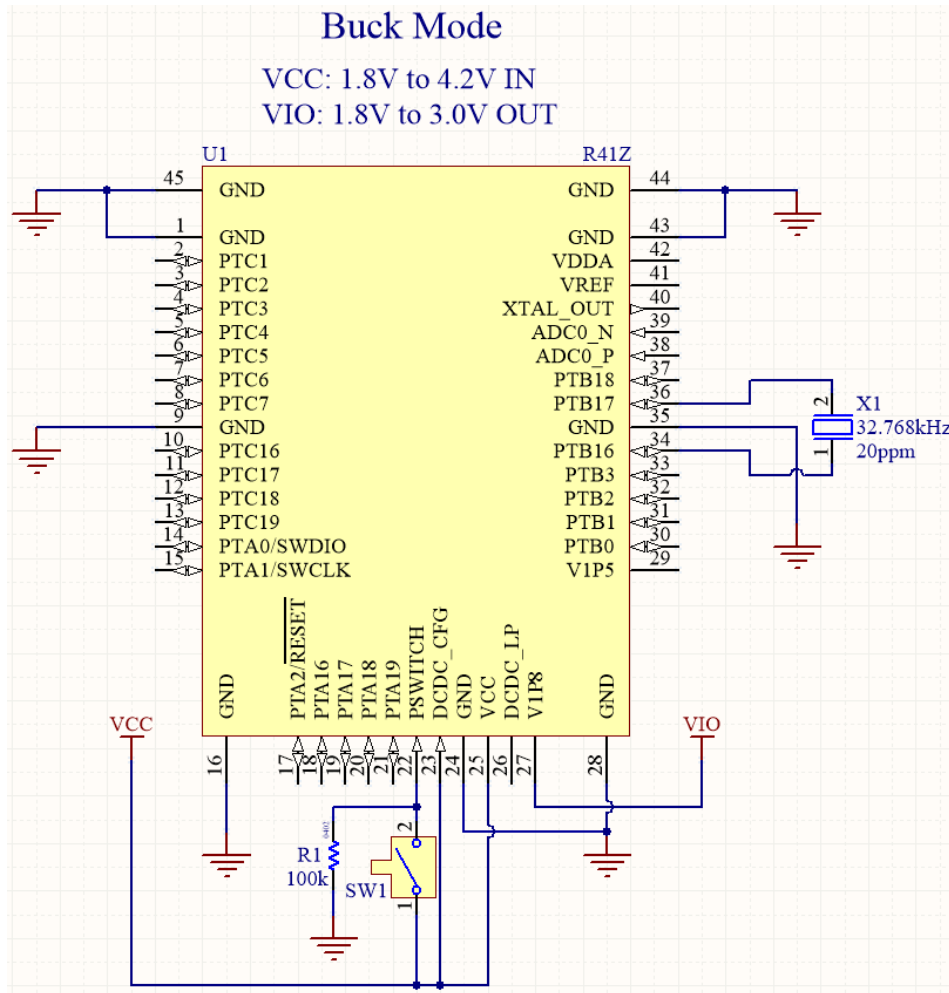

Figure 5 - Schematic: DCDC Buck Mode PSWITCH Example

7.3.3 DCDC Boost Mode

Mode	Pin	Name	Net Connection
Boost	22	PSWITCH	0.9V – 1.8V Source IN
	23	DCDC_CFG	Ground
	25	VCC	0.9V – 1.8V Source IN
	26	DCDC_LP	0.9V – 1.8V Source IN
	27	V1P8	No Connection or 1.8V – 3.0V OUT ¹
	29	V1P5	No Connection

Note 1: V1P8 is the R41Z's IO voltage when the DCDC converter is running in either Buck or Boost mode. V1P8 can source a limited number of additional peripheral devices (sensors, LEDs, etc.) that connect directly to the R41Z's IO.

Table 21 - DCDC Boost Mode Pin Connections

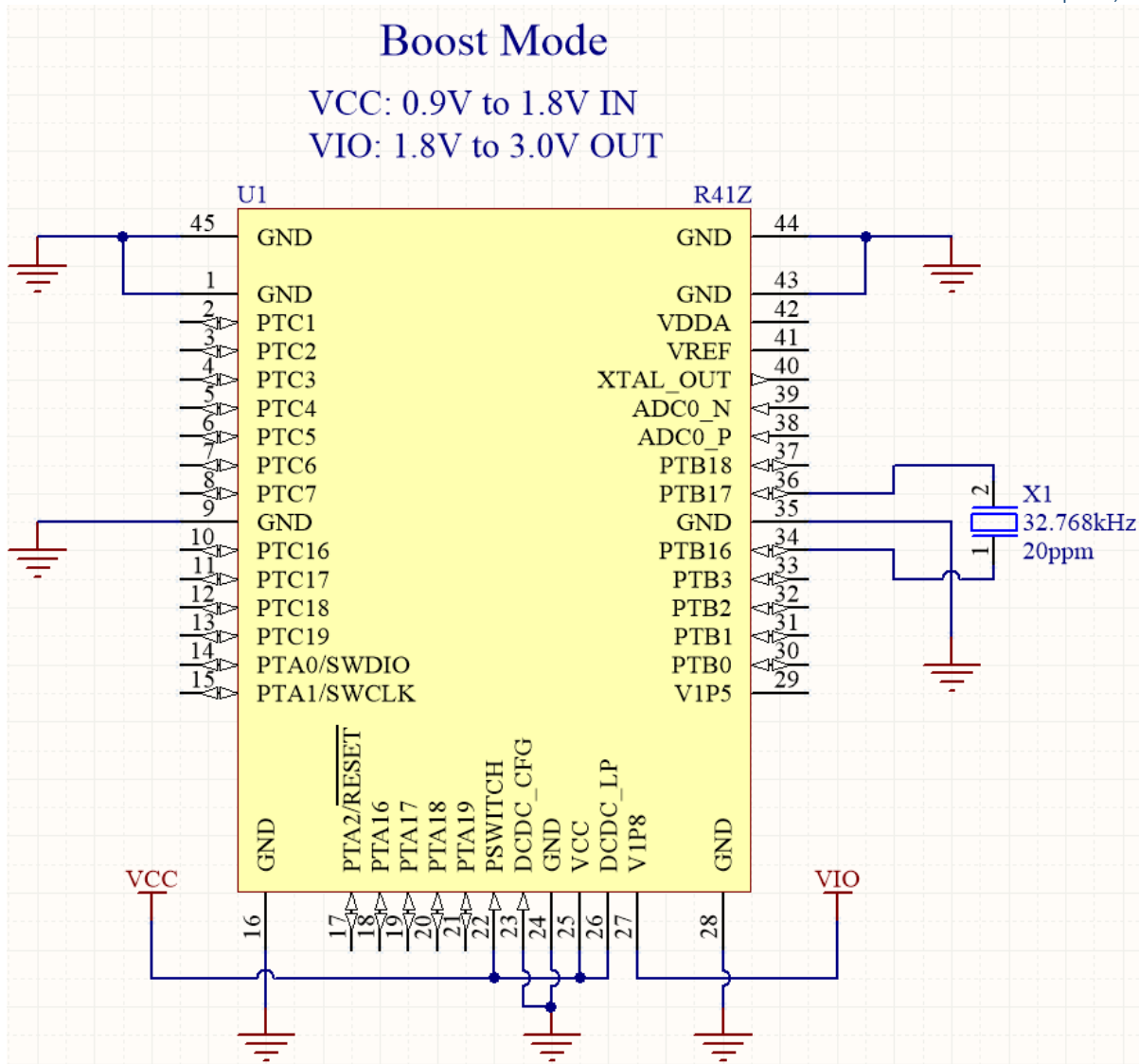

Figure 6 - Schematic: DCDC Boost Mode Example

When using Boost Mode care should be taken to ensure that DCDC_LP (Pin 26) is connected to VCC (Pin 25) with a trace wide enough to carry the full current expected to be drawn from the R41Z module and any peripherals sourced by the module. The connection should also be as short as possible.

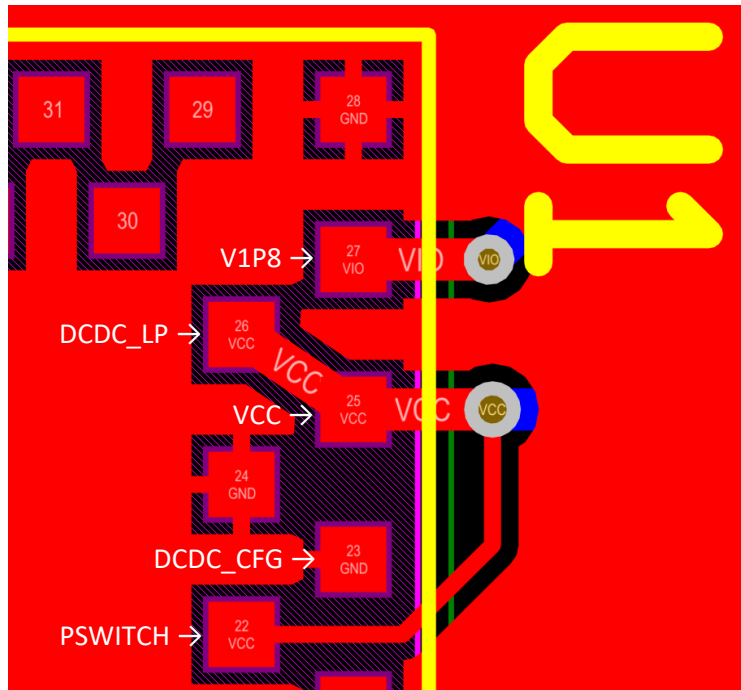

Figure 7 - PCB: Boost Mode Suggested Layout

7.4 General Purpose I/O and ports

The general-purpose I/O is organized as three ports (A, B, and C) that enable access and control to each of the 25 available GPIO pins. Each GPIO can be configured individually through a Pin Control Register (PCR) and Port Data Direction Register (PDDR) with the following available features:

- Input/Output direction
- Output drive strength
- Internal pull-up and pull-down resistors
- Trigger interrupts and/or DMA from input
- Read and clear interrupt flags
- Enable passive input filter
- Fast/slow slew rate selection
- Control pin muxing to internal modules

To use a pin as GPIO set the Pin Mux Control field of the pin to ALT1 in the PCR. Ports must have their clock source enabled in the System Clock Gating Control Register 5 (SIM_SCGC5) before accessing any port registers. Attempting to access port registers without the port clock enabled will cause program execution to immediately vector to the default exception handler. Disabling the clock to ports that are not being used will reduce power consumption. Ports should be disabled before turning off the clock.

Symbol	Parameter	Min	Max.	Unit
V_{IH}	Input High Voltage, $2.7V \leq V_{IO} \leq 3.6V$	$0.7 \times V_{IO}$	-	V
	Input High Voltage, $1.7V \leq V_{IO} \leq 2.7V$	$0.75 \times V_{IO}$	-	V
V_{IL}	Input Low Voltage, $2.7V \leq V_{IO} \leq 3.6V$	-	$0.35 \times V_{IO}$	V
	Input Low Voltage, $1.7V \leq V_{IO} \leq 2.7V$	-	$0.3 \times V_{IO}$	V

Symbol	Parameter	Min	Max.	Unit
V _{HYS}	Input Hysteresis	-	0.06 × V _{IO}	V
V _{OH}	Output High Voltage	V _{IO} – 0.5	-	V
V _{OL}	Output Low Voltage	-	0.5	V
R _P	Pull resistance	20	50	kΩ

Table 22 - GPIO Properties

7.5 Analog I/O and VREF

7.5.1 Analog Signals

Symbol	Parameter	Min	Typ.	Max.	Unit
V _{DDA}	Analog supply voltage	-	V _{1P8}	-	V
V _{REF_OUT}	VREF internally sourced, factory trim	1.190	1.1950	1.200	V
V _{REFH}	VREF externally sourced	1.13	V _{DDA}	V _{DDA}	V
V _{ADIN}	16-bit, differential mode	GND	-	31/32 × V _{REFH}	V
	16-bit, All other modes	GND	-	V _{REFH}	V
V _{ACIN}	CMP/6-bit ADC analog input voltage	GND – 0.3	-	V _{1P8}	V
V _{ACIO}	CMP/6-bit ADC analog input voltage offset	-	-	20	mV
I _{CMPHS}	CMP current, High-speed mode	-	-	200	μA
Symbol	Parameter	Min	Typ.	Max.	Unit
I _{CMPLS}	CMP current, Low-speed mode	-	-	20	μA
V _{CMPH}	Comparator output high	V _{1P8} – 0.5	-	-	V
V _{CMPL}	Comparator output low	-	-	0.5	V

Table 23 - Analog Properties

7.5.2 VDDA and VREF

The source voltage for the analog sub-system, VDDA, is supplied by V1P8 through a filtering circuit onboard the R41Z module. The voltage reference pin, VREF, has two sourcing options: internal or external. When externally supplied, VREF should be referenced to VDDA. Internal VREF is provided by a resistor trimmed circuit. For details on using the analog modules, see the [KW41Z Data Sheet](#).

7.6 Module Reset

Pin 17, PTA2, is used as an external reset source by default. This pin can be used for other functions, such as GPIO, by setting the RESET_PIN_CFG option bit of the FTFA_FPORT register to 0. This bit is retained through system resets and low power modes.

7.7 Debug and Programming

The R41Z module supports the two pin Serial Wire Debug (SWD) interface and offers flexible mechanisms for non-intrusive debugging of program code. Breakpoints, single stepping, and instruction trace capture of code execution flow are part of this support. The R41Z also supports Micro Trace Buffer (MTB) which provides a lightweight program trace capabilities using system RAM. SWD pins can be repurposed as additional GPIO by the application.

The R41Z module does not support resets through the SWD interface. Resets from programmers and test fixtures must be asserted through the reset pin.

7.8 Clocks

7.8.1 General Parameters

The R41Z requires two clocks: a high frequency clock and a low frequency clock.

The high frequency clock is provided on-module by a high accuracy 32-MHz crystal. The low frequency clock is required for Real Time Clock (RTC) operation and radio Deep Sleep Mode (DSM). In most applications, an external crystal oscillator is required to provide the low frequency clock.

For normal run modes, an internal oscillator can provide the low frequency clock. However, to make full use of reduced power modes an external crystal must be present.

For most applications with the low frequency crystal, external capacitors are not required. Internal, programmable capacitors are provided on the R41Z module. To maintain accurate time keeping, these internal capacitors should be adjusted for the PCB's and crystal's characteristics during hardware initialization. Internal capacitance can be configured in 2pF increments using the RTC_CR configuration register.

An external clock source can be used in place of the low frequency crystal. In this case, the clock source should be connected to the EXTAL32K pin (PTB16) and XTAL23K (PTB17) should be left unconnected.

The R41Z's internal 32MHz clock can be provided to other devices using the XTAL_OUT signal on pin 40. This clock output can be toggled via software or externally enabled with the XTAL_OUT_EN signal. See [Section 6.10](#) for XTAL_OUT_EN signal mapping options.

Low Frequency Crystal

Symbol	Parameter	Typ.	Max.	Unit
F _{NOM_LFXO}	Crystal frequency	32.768	-	kHz
F _{TOL_LFXO_BLE}	Frequency tolerance, BLE applications	±20	±250	ppm
C _{L_LFXO}	Load Capacitance	7	12.5	pF

Table 24 – Low Frequency Crystal Recommended Specifications

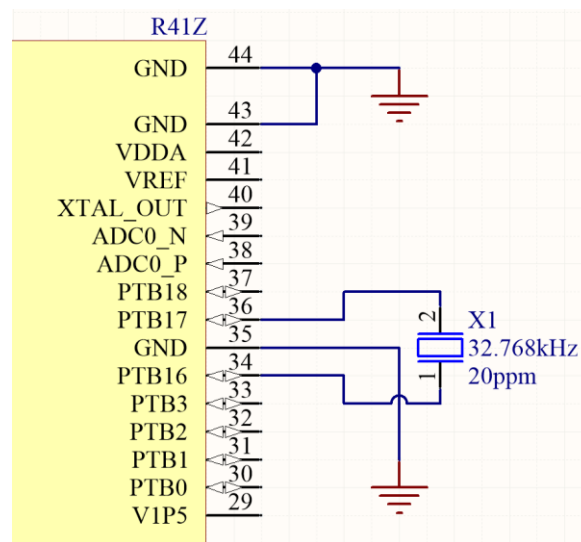

Figure 8 - Schematic: Low Frequency Crystal

8. Firmware

8.1 Factory Image

All modules are shipped with factory programmed firmware. The factory programmed firmware version is indicated on the label.



Factory Firmware
Version Code: **XX**

8.1.1 Firmware Version '00'

R41Z modules marked with firmware version '00' are not loaded with a firmware image at the factory.

Note: When the R41Z does not have a firmware image loaded that can be executed out of Power On Reset (POR), the R41Z module will re-assert POR. This should be considered when connecting the R41Z to other devices on a shared reset circuit.

8.2 Mac Address Info

On R41Z modules, the MAC address is typically located in flash as part of the firmware image and accessed as a global constant. Rigado provides a unique MAC address which may be used in an end application. The MAC address is printed on a 2D barcode and human readable text on the top of the module.



MAC Address:
94:54:93:**XX**:**YY**:**ZZ**

Figure 9 - R41Z MAC Address on Label

When loading custom firmware to the module, the MAC address must be inserted into the image. This can be done manually using the human readable text or automated using a barcode scanner and suitable factory programmer tools. When loading a new application to the module, care should be taken to ensure the Rigado bootloader (if used) and MAC address are not overwritten.

9. Mechanical Data

9.1 Package Dimensions

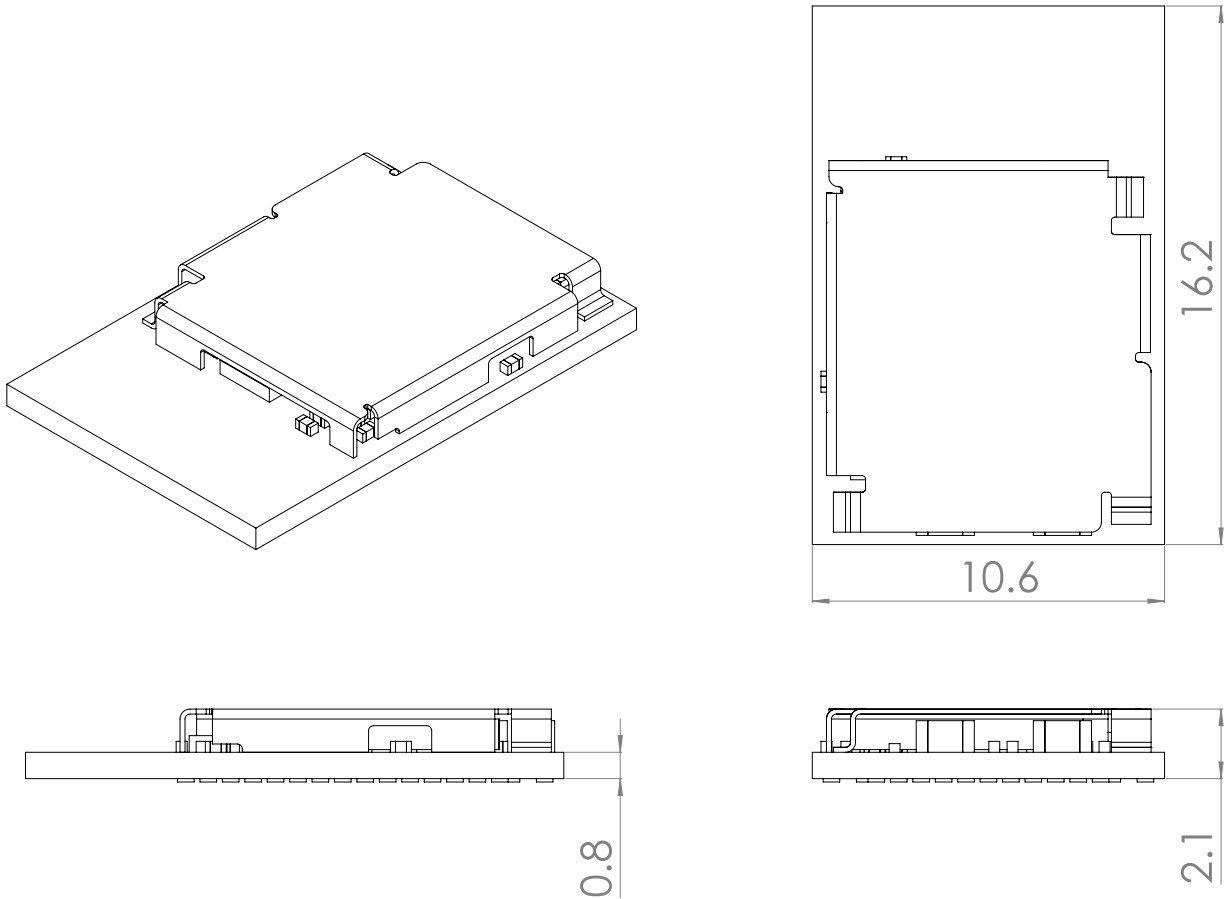

Figure 10 - R41Z Module Dimensions

(All dimensions are in mm)

9.2 Recommended PCB Footprint

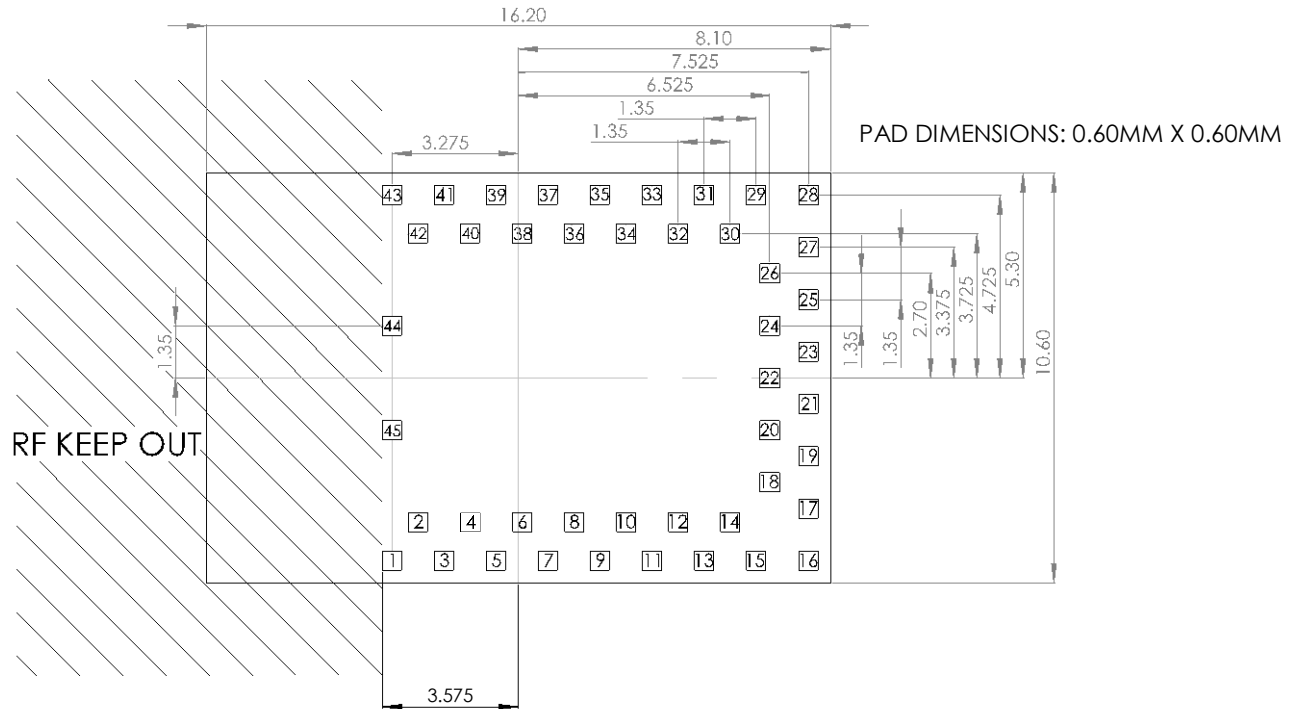

Figure 11 - R41Z Pad Layout (Top View)

(All dimensions are in mm)

10. Module Marking

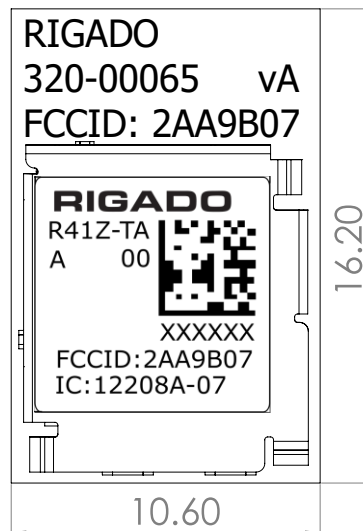

Figure 12 - R41Z Module Marking - RevA

11. RF Design Notes

11.1 Recommended RF layout and Ground Plane

The integrated antenna on the R41Z module requires a suitable ground plane to radiate effectively. The module antenna has been tuned for having a PCB directly below with no copper or any other metal present. The module should be placed at the edge of the PCB with the antenna edge facing out. For best performance, the ground plane should be on the same layer as the module or as close as possible. If this is not possible in a design, ground planes on multiple layers generously connected with vias may also be used. Reduced ground plane size will result in reduced radio performance.



Figure 13 - R41Z RF Example Based on EVAL Board

11.2 Mechanical Enclosure

Care should be taken when designing and placing the module into an enclosure. Metal should be kept clear from the antenna area, both above and below. Any metal around the module can decrease RF performance.

The module is designed and tuned to be in free air. Any potting, epoxy fill, plastic over-molding, or conformal coating can negatively impact RF performance and must be evaluated by the customer. If potting must be used, the compound should have a low dielectric constant and should be designed for use with 2.4GHz RF electronics.

11.3 Antenna Patterns

Antenna patterns are based from the R41Z Evaluation Kit Version 2 with a ground plane size of 82mm x 56mm. X-Y-Z orientation is shown in the figure below:

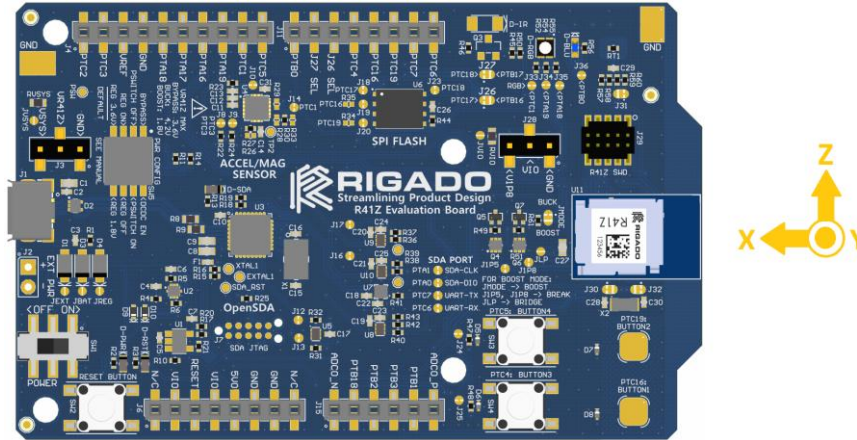

Figure 14 - X-Y-Z Antenna Orientation

11.3.1 X-Y Plane

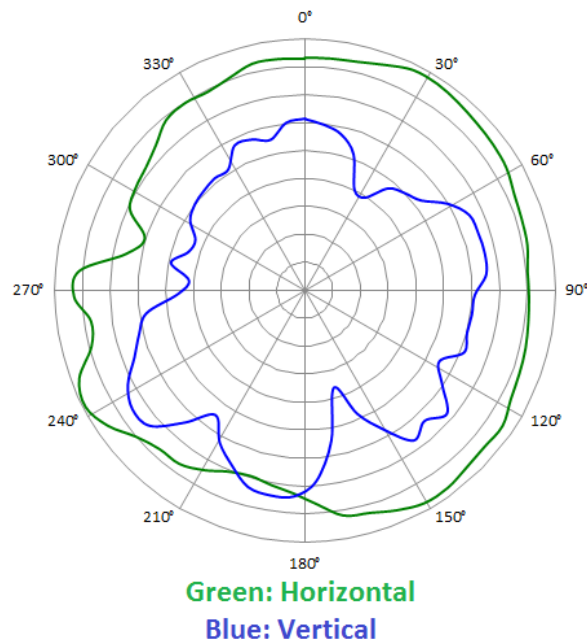
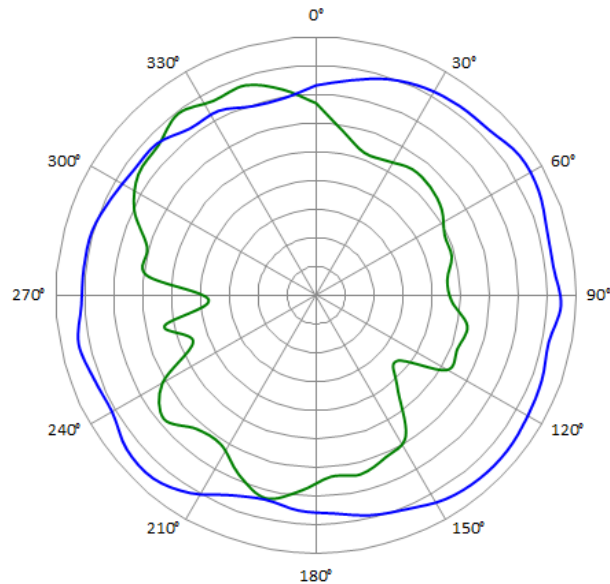

Figure 15 - X-Y Plane Antenna Pattern

11.3.2 Y-Z Plane



Green: Horizontal
Blue: Vertical

Figure 16 - Y-Z Antenna Pattern

11.3.3 Z-X Plane

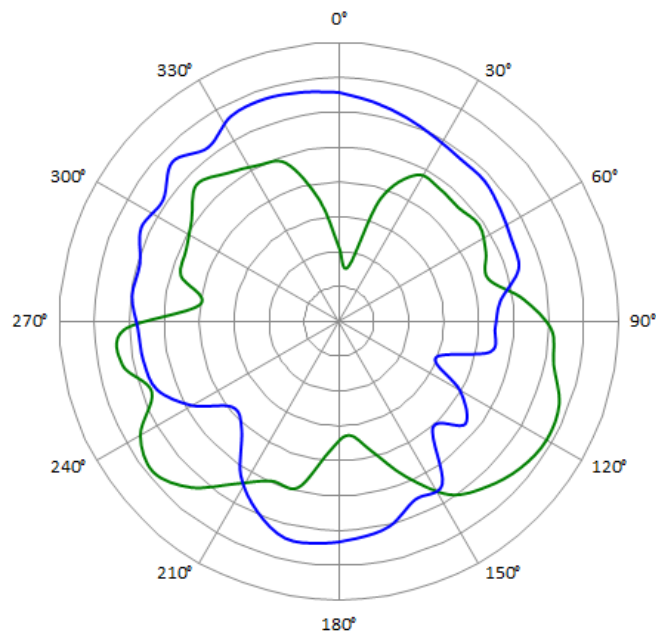

Green: Horizontal
Blue: Vertical

Figure 17 - Z-X Plane Antenna Pattern

12. Evaluation Boards

Rigado has developed a full featured evaluation board that provides on-board programming and debug, power, and virtual COM port over USB, 32.768kHz crystal, Arduino style IO headers 2 mechanical user buttons, 2 capacitive touch buttons, 3-axis accelerometer/magnetometer (I²C), and a 4Mbit flash chip (SPI). The evaluation board also allows for easy use of all the R41Z's DCDC power modes and can be powered from an adjustable LDO regulator, CR2032 coin cell battery, or through an external power header. Power consumption can be measured through onboard current sensing resistors and headers.



Figure 18 - R41Z Evaluation Board

13. Custom Development

Rigado is a full-service design house offering end-to-end product development from concept to manufacturing. We can provide custom modules and DevOps management tools, perform electrical and mechanical design, firmware and mobile development, and end product manufacturing.

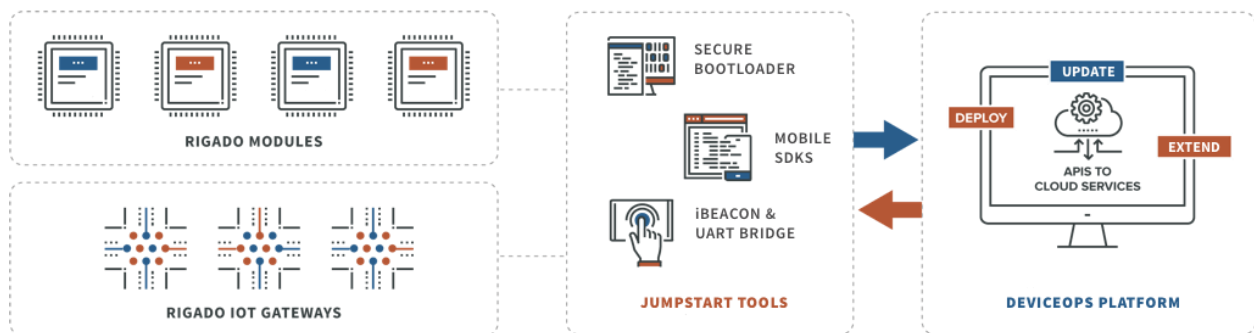

14. Bluetooth Qualification

The R41Z module is being qualified as a Bluetooth Component (tested) for RF-PHY. This allows for customers to use qualified NXP Bluetooth stacks without the need to complete additional RF-PHY testing.

- R41Z: Declaration ID TBD / QDID TBD

15. Regulatory Statements

15.1 FCC Statement

This device has been tested and found to comply with part 15 of the FCC rules. These limits are designed to provide reasonable protection against harmful interference in a residential installation. This equipment generates, uses and can radiate radio frequency energy and, if not installed and used in accordance with the instructions, may cause harmful interference to radio communications. However, there is no guarantee that interference will not occur in a particular installation. If this equipment does cause harmful interference to radio or television reception, which can be determined by turning the equipment off and on, the user is encouraged to try to correct the interference by one or more of the following measures:

- Reorient or relocate the receiving antenna.
- Increase the separation between the equipment and the receiver
- Connect the equipment into an outlet on a circuit different from that to which the receiver is connected.
- Consult the dealer or an experienced radio/TV technician for help.

Operation is subjected to the following two conditions: (1) This device may no cause harmful interference, and (2) this device must accept any interference received, including interference that may cause undesired operation. Note: Modification to this product will void the user's authority to operate this equipment.

Note: Modification to this product will void the users' authority to operate this equipment.

15.2 FCC Important Notes:

(1) FCC Radiation Exposure Statement

This equipment complies with FCC RF radiation exposure limits set forth for an uncontrolled environment. This transmitter must not be co-located or operating in conjunction with any other antenna or transmitter.

This equipment complies with Part 15 of the FCC Rules. Operation is subject the following two conditions:

- (1) This device may not cause harmful interference, and

(2) This device must accept any interference received, including interference that may cause undesired operation.

The devices must be installed and used in strict accordance with the manufacturer's instructions as described in this document.

Caution!

The manufacturer is not responsible for any radio or TV interference caused by unauthorized modifications to this equipment. Such modification could void the user authority to operate the equipment.

(2) Co-location Warning:

This device and its antenna(s) must not be co-located or operating in conjunction with any other transmitter antenna.

(3) OEM integration instructions:

This device is intended only for OEM integrators under the following conditions:

The antenna and transmitter must not be co-located with any other transmitter or antenna. The module shall be only used with the integral antenna(s) that has been originally tested and certified with this module.

As long as the two (2) conditions above are met, further transmitter testing will not be required. However, the OEM integrator is still responsible for testing their end-product for any additional compliance requirements with this module installed (for example, digital device emission, PC peripheral requirements, etc.)

In the event that these conditions cannot be met (for example certain laptop configuration or co-location with another transmitter), then the FCC authorization for this module in combination with the host equipment is no longer considered valid and the FCC ID of the module cannot be used on the final product. In these and circumstance, the OEM integrator will be responsible for re-evaluating. The end product (including the transmitter) and obtaining a separate FCC authorization.

Caution!

The OEM is still responsible for verifying end product compliance with FCC Part 15, subpart B limits for unintentional radiators through an accredited test facility.

(4) End product labeling:

The final end product must be labeled in a visible area with the following:

- "Contains **FCC ID: 2AA9B07**"
- Any similar wording that expresses the same meaning may be used.

The FCC Statement below should also be included on the label. When not possible, the FCC Statement should be included in the User Manual of the host device.

“This device complies with part 15 of the FCC rules.

Operation is subject to the following two conditions. (1) This device may not cause harmful interference. (2) This device must accept any interference received, including interference that may cause undesired operation.”

(5) Information regarding the end user manual :

The OEM integrator has to be aware not to provide information to the end user regarding how to install or remove this RF module in the user’s manual of the end product which integrates this module. The end user manual shall include all required regulatory information/warning as show in this manual (Section 15.2(4)).

15.3 IC Statement:

This device complies with Industry Canada license-exempt RSS standard(s). Operation is subject to the following two conditions: (1) this device may not cause interference, and (2) this device must accept any interference, including interference that may cause undesired operation of the device.

Le présent appareil est conforme aux CNR d'Industrie Canada applicables aux appareils radio exempts de licence. L'exploitation est autorisée aux deux conditions suivantes : (1) l'appareil ne doit pas produire de brouillage, et (2) l'utilisateur de l'appareil doit accepter tout brouillage radioélectrique subi, même si le brouillage est susceptible d'en compromettre le fonctionnement.

RF exposure warning: The equipment complies with RF exposure limits set forth for an uncontrolled environment. The antenna(s) used for this transmitter must not be co-located or operating in conjunction with any other antenna or transmitter.

Avertissement d'exposition RF: L'équipement est conforme aux limites d'exposition aux RF établies pour un incontrôlés environnement. L'antenne (s) utilisée pour ce transmetteur ne doit pas être co-localisés ou onctionner en conjonction avec toute autre antenne ou transmetteur .

15.4 IC Important Notes:

1. The OEM integrator has to be aware not to provide information to the end user regarding how to install or remove this RF module in the user manual of the end product.

The user manual which is provided by OEM integrators for end users must include the following information in a prominent location.

2. To comply with IC RF exposure compliance requirements, the antenna used for this transmitter must not be co-located or operating in conjunction with any other antenna or transmitter, except in accordance with IC multi-transmitter product procedures.

3. The final system integrator must ensure there is no instruction provided in the user manual or customer documentation indicating how to install or remove the transmitter module except such device has implemented two-ways authentication between module and the host system.

4. The host device shall be properly labelled to identify the module within the host device. The final end product must be labeled in a visible area with the following:

“Contains IC: 12208A-07”

Any similar wording that expresses the same meaning may be used.

The IC Statement below should also be included on the label. When not possible, the IC Statement should be included in the User Manual of the host device.

“This device complies with Industry Canada license-exempt RSS standard(s). Operation is subject to the following two conditions: (1) this device may not cause interference, and (2) this device must accept any interference, including interference that may cause undesired operation of the device.

Le présent appareil est conforme aux CNR d'Industrie Canada applicables aux appareils radio exempts de licence. L'exploitation est autorisée aux deux conditions suivantes : (1) l'appareil ne doit pas produire de brouillage, et (2) l'utilisateur de l'appareil doit accepter tout brouillage radioélectrique subi, même si le brouillage est susceptible d'en compromettre le fonctionnement.”

15.5 CE Regulatory:

The R41Z modules are being tested and expected to be compliant against the following standards. OEM integrators should consult with qualified test house to verify all regulatory requirements have been met for their complete device.

From Directive 2006/95/EC:

- EN 60950-1: 2006 + A11: 2009 + A1: 2010 + A12: 2011

From R&TTE Directive 1999/5/EC:

- ETSI EN 300 328 V 1.9.1

From Directive 2004/108/EC:

- ETSI EN 301 489-1 V1.9.2
- ETSI EN 301 489-17 V2.2.1

Declarations of Conformity and supporting test reports are available at www.rigado.com.

15.6 Japan (MIC)

The R41Z Series modules are pending type certification and are to be labeled with its own technical conformity mark and certification number as required to conform to the technical standards regulated by the Ministry of Internal Affairs and Communications (MIC) of Japan pursuant to the Radio Act of Japan. Integration of this module into a final end product does not require additional radio certification provided installation instructions are followed and no modifications of the module are allowed.

Additional testing may be required:

- If the host product is subject to electrical appliance safety (for example, powered from an AC mains), the host product may require Product Safety Electrical Appliance and Material (PSE) testing. The integrator should contact their conformance laboratory to determine if this testing is required.

- There is a voluntary Electromagnetic Compatibility (EMC) test for the host product administered by VCCI: http://www.vcci.jp/vcci_e/index.html

The label on the final end product which contains a R41Z Series module must follow the MIC marking requirements. Labeling requirements for Japan available at the Ministry of Internal Affairs and Communications (MIC) website: <http://www.tele.soumu.go.jp/e/index.htm>.

The R41Z module is to be labeled with its assigned technical conformity mark and certification number. The final end product in which this module is being used must have an external label referring to the type certified module inside:

Contains transmitter module with certificate number:

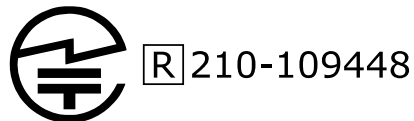

15.7 Australia / New Zealand

The R41Z module have been tested to comply with the AS/NZS 4268 :2012+AMDT 1:2013, Radio equipment and systems – Short range devices – Limits and methods of measurement. The report (Pending) may be downloaded from www.rigado.com, and may be used as evidence in obtaining permission to use the RCM.

Information on registration as a Responsible Party, license and labeling requirements may be found at the following websites:

Australia: <http://www.acma.gov.au/theACMA/radiocommunications-short-range-devices-standard-2004>

New Zealand: <http://www.rsm.govt.nz/compliance>

The A-Tick and C-Tick marks are being migrated to the Regulatory Compliance Mark (RCM). Only Australian-based and New Zealand-based companies who are registered may be granted permission to use the RCM. An Australian-based or New Zealand-based agent or importer may also register as a Responsible Party to use the RCM on behalf of a company not in Australia or New Zealand.

16. Solder Reflow Temperature-Time Profile

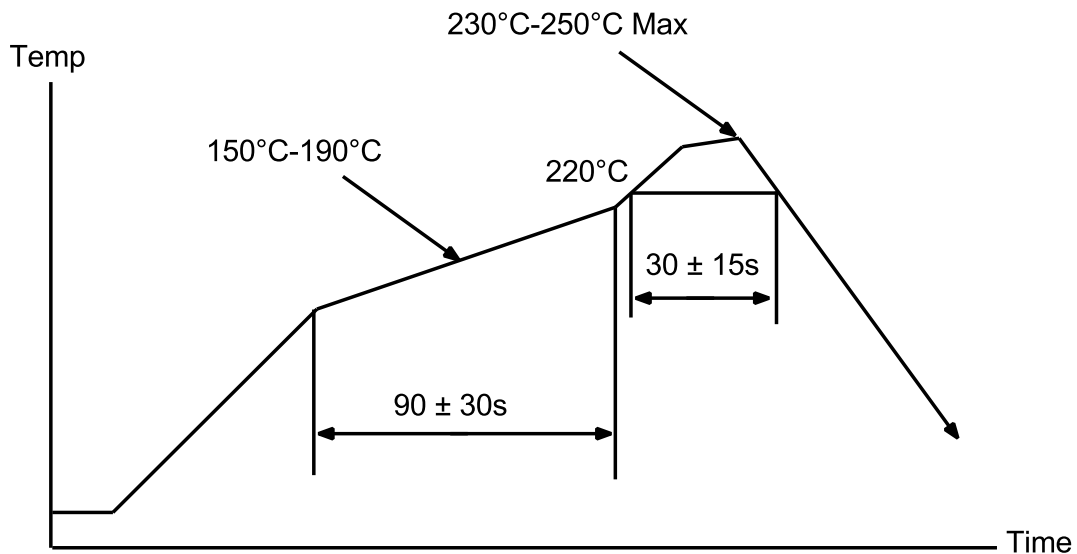

Figure 19 - Reflow Profile for Lead Free Solder

16.1 Moisture Sensitivity Level

The R41Z module is rated for MSL 3, 168-hour floor life after opening.

17. Packaging and Labeling

17.1 Carrier Tape Dimension

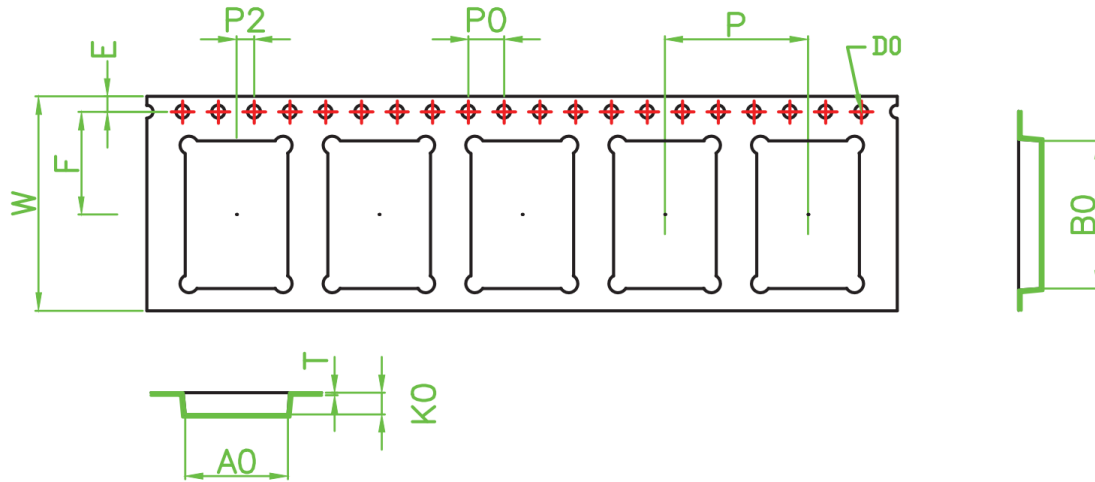

W	24.00±0.30	P	16.00±0.10	A0	11.50±0.10	B0	16.50±0.10
S	0.00±0.10	P0	4.00±0.10	A1		B1	
E	1.75±0.10	P2	2.00±0.10			B2	
F	11.50±0.10	D0	∅1.50 ^{+0.10} ₀	K0	2.40±0.10	K1	
T	0.30±0.05	D1					

Figure 20 - Carrier Tape Dimension

17.2 Reel Packaging

Modules come on 330mm reels loaded with 1000 modules. Each reel is placed in an antistatic bag with a desiccant pack and humidity card and placed in a 340x350x65mm box. On the outside of the bag an antistatic warning and reel label are adhered.

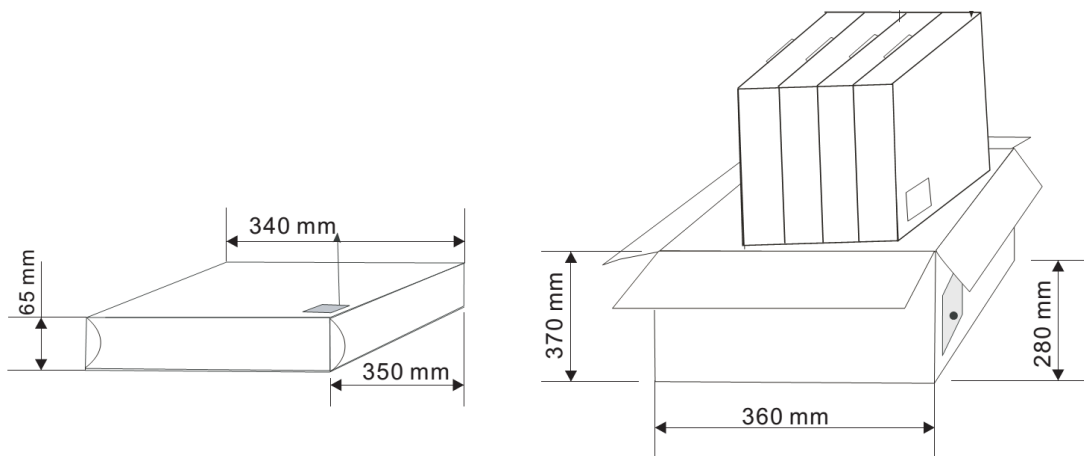

Figure 21 - Reel Cartons

17.3 Packaging Label



Figure 22 - Packaging Label

18. Cautions

- 1) The guidelines of this document should be followed in order to assure proper performance of the module.
- 2) This product is for use in office, business, and residential applications, but not medical devices.
- 3) This module may short-circuit. If a short circuit can result in serious damage or injury then failsafe precautions should be used. This could be accomplished by redundant systems and protection circuits.
- 4) Supply voltage to the module should not be higher than the specified inputs or reversed. Additionally, it should not contain noise, spikes, or AC ripple voltage.
- 5) Avoid use with other high frequency circuits.
- 6) Use methods to eliminate static electricity when working with the module as it can damage the components.
- 7) Contact with wires, the enclosure, or any other objects should be avoided.
- 8) Refer to the recommended pattern when designing for this module.
- 9) If hand soldering is used, be sure to use the precautions outlined in this document.
- 10) This module should be kept away from heat, both during storage and after installation.
- 11) Do not drop or physically shock the module.
- 12) Do not damage the interface surfaces of the module.
- 13) The module should not be mechanically stressed at any time (storage, handling, installation).
- 14) Do not store or expose this module to:
 - Humid or salty air conditions
 - High concentrations of corrosive gasses.
 - Long durations of direct sunlight.
 - Temperatures lower than -40°C or higher than 125°C.

19. Life Support Policy

This product is not designed to be used in a life support device or system, or in applications where there is potential for a failure or malfunction to, directly or indirectly, cause significant injury. By using this product in an application that poses these risks, such as described above, the customer is agreeing to indemnify Rigado for any damages that result.

20. Document History

Revision	Date	Changes / Notes
0.9	10/20/2016	Initial Release
1.0	12/21/2016	Added: Certifications, Antenna patterns, Carrier tape info. Images updated
1.1	4/21/2017	Added: Additional pin mux tables, errata note in section 6. Fixed: Missing section link to 7.3.3, incorrect RF keep out dimension in Figure 11.

21. Related Documents

Rigado Documents:

- [R41Z Module Product Brief](#)
- [R41Z Eval Board User Guide](#)

NXP Documents:

- [KW41Z Fact Sheet](#)
- [NXP BLE Mobile Toolbox](#)
- [KW41Z Data Sheet](#)
- [KW41Z Reference Manual](#)
- [KW41Z Errata Sheet](#)
- [AN3863: Designing Touch Sensing Electrodes](#)



Компания «ЭлектроПласт» предлагает заключение долгосрочных отношений при поставках импортных электронных компонентов на взаимовыгодных условиях!

Наши преимущества:

- Оперативные поставки широкого спектра электронных компонентов отечественного и импортного производства напрямую от производителей и с крупнейших мировых складов;
- Поставка более 17-ти миллионов наименований электронных компонентов;
- Поставка сложных, дефицитных, либо снятых с производства позиций;
- Оперативные сроки поставки под заказ (от 5 рабочих дней);
- Экспресс доставка в любую точку России;
- Техническая поддержка проекта, помощь в подборе аналогов, поставка прототипов;
- Система менеджмента качества сертифицирована по Международному стандарту ISO 9001;
- Лицензия ФСБ на осуществление работ с использованием сведений, составляющих государственную тайну;
- Поставка специализированных компонентов (Xilinx, Altera, Analog Devices, Intersil, Interpoint, Microsemi, Aeroflex, Peregrine, Syfer, Eurofarad, Texas Instrument, Miteq, Cobham, E2V, MA-COM, Hittite, Mini-Circuits, General Dynamics и др.);

Помимо этого, одним из направлений компании «ЭлектроПласт» является направление «Источники питания». Мы предлагаем Вам помощь Конструкторского отдела:

- Подбор оптимального решения, техническое обоснование при выборе компонента;
- Подбор аналогов;
- Консультации по применению компонента;
- Поставка образцов и прототипов;
- Техническая поддержка проекта;
- Защита от снятия компонента с производства.



Как с нами связаться

Телефон: 8 (812) 309 58 32 (многоканальный)

Факс: 8 (812) 320-02-42

Электронная почта: org@eplast1.ru

Адрес: 198099, г. Санкт-Петербург, ул. Калинина, дом 2, корпус 4, литера А.