

# C120/C500/C1000H/C2000H

## Analog I/O Modules

Cat. No. W121-E3-1

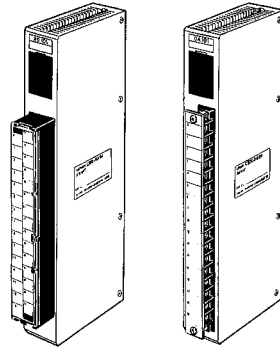





## Notice:

OMRON products are manufactured for use according to proper procedures by a qualified operator and only for the purposes described in this manual.

The following conventions are used to indicate and classify precautions in this manual. Always heed the information provided with them. Failure to heed precautions can result in injury to people or damage to the product.

 **DANGER!** Indicates information that, if not heeded, is likely to result in loss of life or serious injury.

 **WARNING** Indicates information that, if not heeded, could possibly result in loss of life or serious injury.

 **Caution** Indicates information that, if not heeded, could result in relatively serious or minor injury, damage to the product, or faulty operation.

## OMRON Product References

All OMRON products are capitalized in this manual. The terms *Unit* and *Module* are capitalized when referring to an OMRON product.

The abbreviation “Ch,” which appears in some displays and on some OMRON products, often means “word” and is abbreviated “Wd” in documentation in this sense.

The abbreviation “PLC” means Programmable Controller and is not used as an abbreviation for anything else.

## Visual Aids

The following headings appear in the left column of the manual to help you locate different types of information.

**Note** Indicates information of particular interest for efficient and convenient operation of the product.

**1, 2, 3...** 1. Indicates lists of one sort or another, such as procedures, checklists, etc.

### © OMRON, 1996

All rights reserved. No part of this publication may be reproduced, stored in a retrieval system, or transmitted, in any form, or by any means, mechanical, electronic, photocopying, recording, or otherwise, without the prior written permission of OMRON.

No patent liability is assumed with respect to the use of the information contained herein. Moreover, because OMRON is constantly striving to improve its high-quality products, the information contained in this manual is subject to change without notice. Every precaution has been taken in the preparation of this manual. Nevertheless, OMRON assumes no responsibility for errors or omissions. Neither is any liability assumed for damages resulting from the use of the information contained in this publication.



# TABLE OF CONTENTS

## SECTION 1

<b>System Design</b> .....	<b>1</b>
1-1 Introduction .....	2
1-2 Basic Configuration .....	2
1-3 Example Configurations .....	3
1-4 Allocated Words .....	3

## SECTION 2

<b>Components and Switch Settings</b> .....	<b>5</b>
2-1 AD101 Analog Input Modules .....	6
2-2 DA101 Analog Output Modules .....	9

## SECTION 3

<b>Installation</b> .....	<b>11</b>
3-1 AD001 through AD005 Analog Input Modules .....	12
3-2 AD006 and AD007 Analog Input Modules .....	15
3-3 AD101 Analog Input Modules .....	18
3-4 DA001 through DA005 Analog Output Modules .....	21
3-5 DA101 Analog Output Modules .....	24

## SECTION 4

<b>Operation</b> .....	<b>27</b>
4-1 AD001 through AD005 Analog Input Modules .....	28
4-2 AD006 and AD007 Analog Input Modules .....	30
4-3 AD101 Analog Input Modules .....	31
4-4 DA001 through DA005 Analog Output Modules .....	40
4-5 DA101 Analog Output Modules .....	43

## SECTION 5

<b>Programming Considerations</b> .....	<b>47</b>
5-1 AD001 through AD005 Analog Input Modules .....	48
5-2 AD006 and AD007 Analog Input Modules .....	50
5-3 AD101 Analog Input Modules .....	52
5-4 DA001 through DA005 Analog Output Modules .....	69
5-5 DA101 Analog Output Modules .....	71

<b>Appendix A – Standard Models</b> .....	<b>73</b>
---	-----------

<b>Appendix B – Specifications</b> .....	<b>75</b>
--	-----------

<b>Index</b> .....	<b>81</b>
--------------------	-----------

<b>Revision History</b> .....	<b>83</b>
-------------------------------	-----------



## About this Manual:

This manual describes the installation and operation of Analog Input Modules and Analog Output Modules for the C120, C500, C1000H, and C2000H SYSMAC C-series PLCs. These Modules are classified as Special I/O Modules and include the following:

### Analog Input Modules

The Analog Input Modules convert analog inputs to digital (binary) form. The type and range of input as well as the digital format depend on the model. Some models provide additional features such as peak values, means, or scaling.

PLC	Applicable models
C120	3G2A6-AD001 3G2A6-AD002 3G2A6-AD003 3G2A6-AD004 3G2A6-AD005 3G2A6-AD006 3G2A6-AD007
C500 C1000H C2000H	C500-AD101 3G2A5-AD001 3G2A5-AD002 3G2A5-AD003 3G2A5-AD004 3G2A5-AD005 3G2A5-AD006 3G2A5-AD007

### Analog Output Modules

Analog Output Modules convert digital (binary) data to analog outputs. The type and range of output as well as the digital format depend on the model.

PLC	Applicable models
C120	3G2A6-DA001 3G2A6-DA002 3G2A6-DA003 3G2A6-DA004 3G2A6-DA005
C500 C1000H C2000H	C500-DA101 3G2A5-DA001 3G2A5-DA002 3G2A5-DA003 3G2A5-DA004 3G2A5-DA005

Be sure to familiarize yourself with the information in this manual and your PLC's *Operation Manual* before you try to install or use an Analog I/O Module.

### Model References

If an Analog I/O Module is referred to using only the last half of the model number (i.e., 3G2A5 or 3G2A6 is omitted), the information being provided applies to all Modules whose model number ends with the number given.





# SECTION 1

## System Design

This section describes the basic use of Analog I/O Modules in a Control System and illustrates the type of applications in which they might be found.

1-1	Introduction .....	2
1-2	Basic Configuration .....	2
1-3	Example Configurations .....	3
1-4	Allocated Words .....	3
1-4-1	AD001 through AD005 Analog Input Modules .....	4
1-4-2	AD006 and AD007 Analog Input Modules .....	4
1-4-3	AD101 Analog Input Modules .....	4
1-4-4	DA001 through DA005 Analog Output Modules .....	4
1-4-5	DA101 Analog Output Modules .....	4

### 1-1 Introduction

Analog I/O Modules are used to interface the digital operation of the PLC with analog I/O field devices. Analog Input Modules convert analog signal from input devices to digital PLC data. Analog Output Modules convert digital PLC data to analog signals for output devices.

### 1-2 Basic Configuration

This diagram shows some of the possible field devices for the Analog I/O Modules. Any I/O device may be used as long as its voltage/current requirements fall within the specified ranges (see *Appendix B*).

The I/O device connected to the Analog I/O Module will often serve as an interface for another device, e.g., a preamplifier may interface a pressure gauge to increase the signal level to Analog Input Module requirements; a regulator may interface a heating system to control temperature.

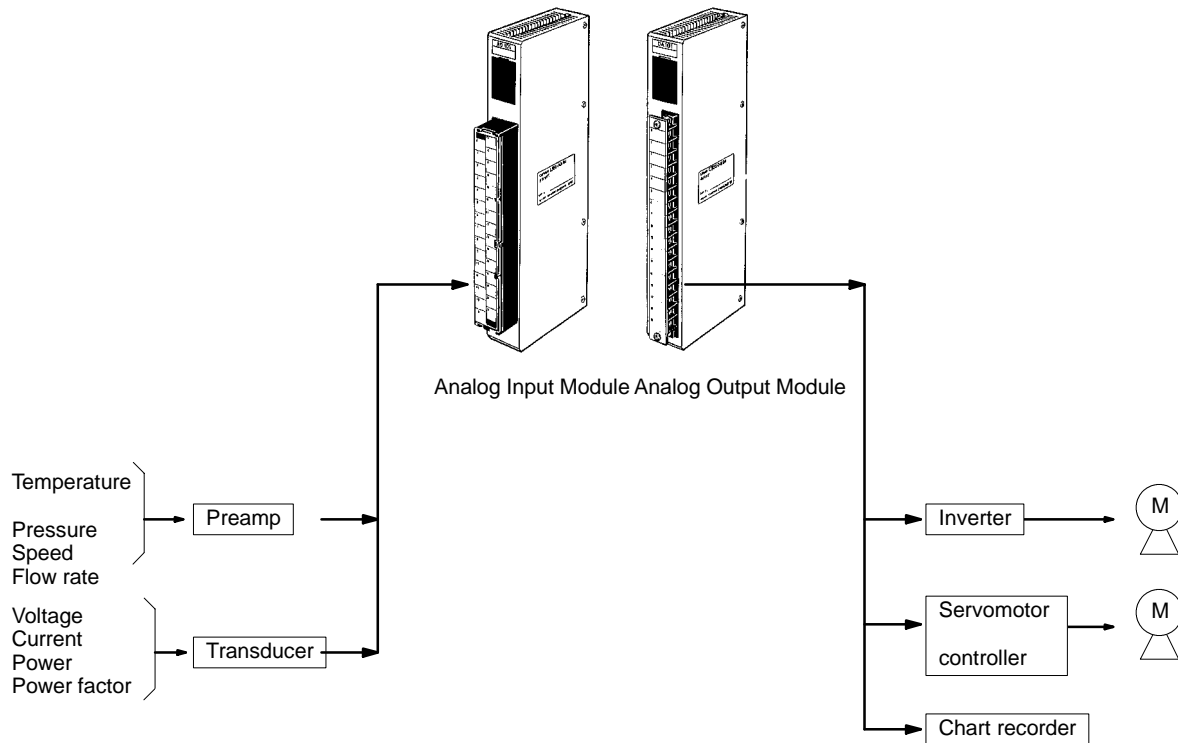

### 1-3 Example Configurations

Below are two examples of how the Analog I/O Modules can be employed in control systems. The first diagram shows a temperature regulating system and the second shows a servomotor positioning system.

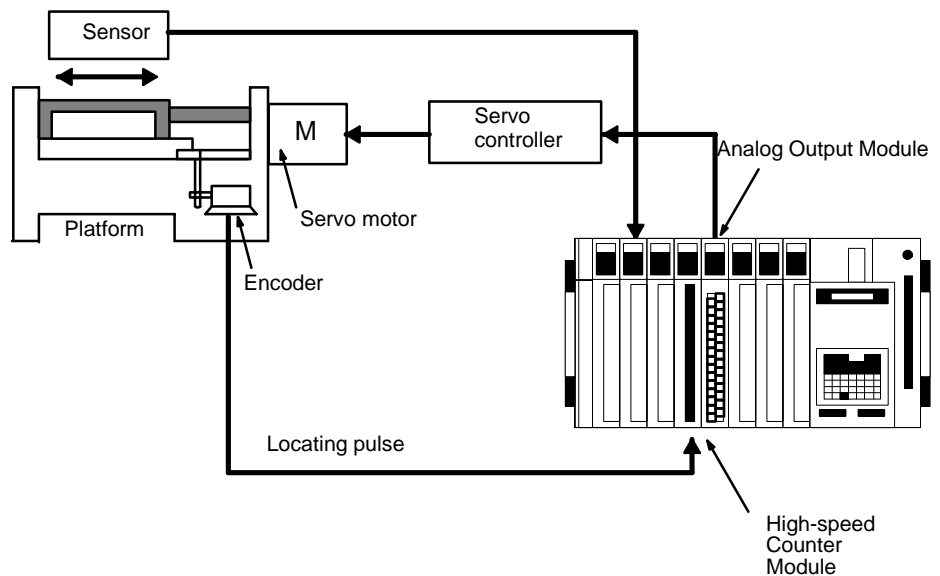
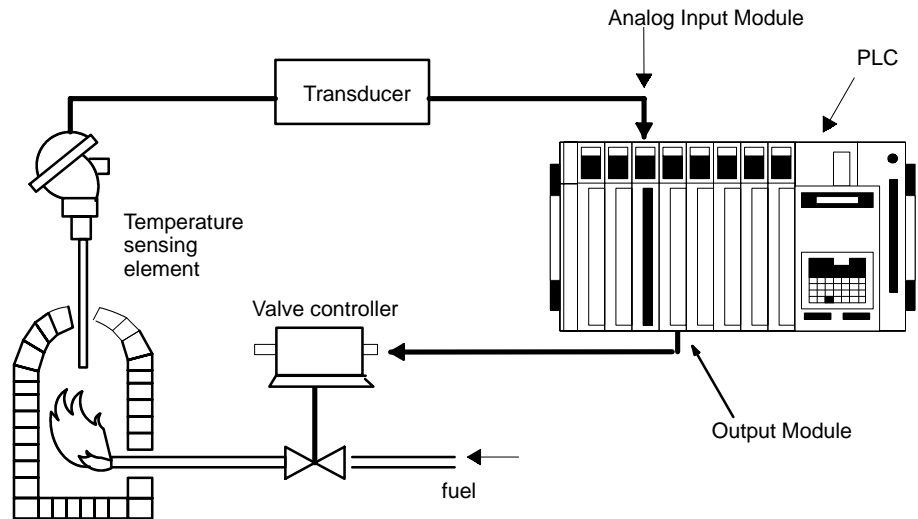

### 1-4 Allocated Words

Each Analog I/O Module is allocated either two or four words. This section specifies only the actual number of words allocated to the Modules; use of these words is dealt with in *Section 4 Operation*.

The first word allocated to the Module is designated as “n” in this manual. Remaining words, which are always consecutive, are designated as n+1, n+2, etc. Refer to your PLC’s *Operation Manual* for details on how words are allocated to Modules.

**1-4-1 AD001 through AD005 Analog Input Modules**

Each of these Analog Input Modules is allocated two words, one for each analog input point. Word  $n$  is for point 1, and word  $n+1$  is for point 2. Each of these words contains the decimal-converted value for the analog input point.

**1-4-2 AD006 and AD007 Analog Input Modules**

Each of these Analog Input Modules is allocated four words, one for each analog input point. Word  $n$  is for point 1, word  $n+1$  is for point 2, word  $n+2$  is for point 3, and word  $n+3$  is for point 4. Each of these words contains the decimal-converted value for the analog input point.

**1-4-3 AD101 Analog Input Modules**

Each of these Analog Input Modules is allocated either two or four words, depending on the switch settings. The operation of the Module is completely different depending on this switch setting. Refer to later sections of this manual for details.

**1-4-4 DA001 through DA005 Analog Output Modules**

Each of these Analog Output Modules is allocated two words, one for each analog output point. Word  $n$  is for point 1; word  $n+1$  is for point 2. Each of these words contains the digital-converted value for the analog output point.

**1-4-5 DA101 Analog Output Modules**

Each of these Analog Output Modules is allocated four words, one for each analog output point. Word  $n$  is for point 1, word  $n+1$  is for point 2, word  $n+2$  is for point 3, and word  $n+3$  is for point 4. Each of these words contains the digital-converted value for the analog output point.

# SECTION 2

## Components and Switch Settings

This section describes the switch settings for the AD101 Analog Input Module and the DA101 Analog Output Module. There are no switch settings required on the other Analog I/O Modules.

2-1 AD101 Analog Input Modules .....	6
2-2 DA101 Analog Output Modules .....	9

## 2-1 AD101 Analog Input Modules

There are two settings necessary for this Module: the operation mode and the input ranges (offset and gain) for each input point

### Operation Mode

Select either two-word or four-word operation. If you select two-word operation, data is transferred between the Analog Input Module and PLC using the I/O READ and I/O WRITE instructions, WRIT(87) and READ(88). If you select four-word operation, data is transferred between the Analog Input Module and PLC via the MOVE instruction, MOV(21).

Use of WRIT(87) and READ(88) will simplify programming and shorten the time required to access analog input data.

The switch for this setting is on the back of the Module and will not be accessible while the Module is mounted to a Rack. Be sure to set this switch before mounting the Module to the PLC. The setting of the switch is read when the PLC power is turned ON.

**Caution** Only the following C120 and C500 CPUs are equipped with WRIT(87) and READ(88), which are required for two-word operation: 3G2C4-SC023-E and 3G2C3-CPU11-EV1. With all other C120 and C500 CPUs, you must use four-word operation. These instructions are supported by all C1000H and C2000H CPUs. Two-word operation is not possible if the Analog I/O Module is mounted to a Slave Rack in a Remote I/O System, regardless of the CPU.

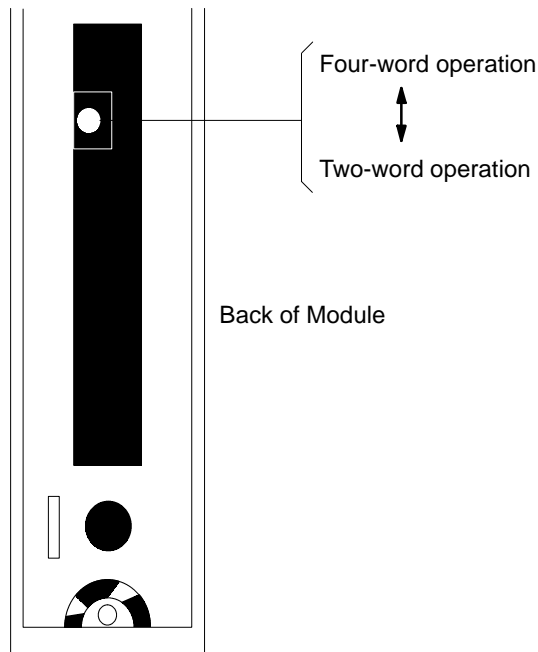

### Input Ranges

Each input point is set with an offset (minimum) of 1 V (4 mA) and a gain (maximum) of 5 V (20 mA) at the factory. Use the following procedure to change these settings if necessary. The offset and gain can be set to anywhere between 0 and 10 V (0 and 20 mA) as long as the gain is greater than the offset. (Refer to *Section 3 Operation* for details on AD conversion.)

**Caution** If an offset is set below 0 V (0 mA), the binary-converted value will be locked at 000<sub>hex</sub>; if a gain is set above 10 V (20 mA), the binary-converted value will be locked at FFF<sub>hex</sub> for voltage inputs, but not for current inputs.

- 1, 2, 3... 1. First set up a power source and meter. For voltage inputs, you will need a 0 to 10 VDC supply and a DC voltmeter. For current input, you will need a 0 to 20 mA DC supply and a DC ammeter. Mount the Module to the PLC and connect the power source and meter. Voltage and current specifications can be set independently for each input point. The following examples illustrate how to wire the input points

Wiring when input 1 is set at 0 to 10 V:

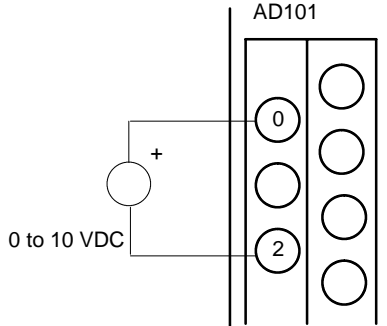

Wiring when input 5 is set at 0 to 20 mA:

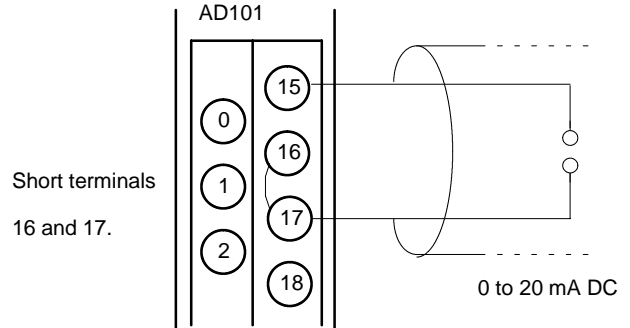

2. Turn the PLC power supply and confirm that power is being supplied to the PLC.

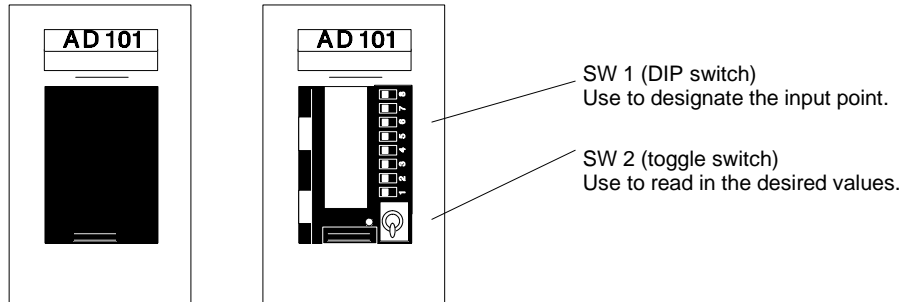

3. Remove the front panel of the Module with flat-blade screwdriver. Pins 1 through 8 on SW 1 represent input points 1 through 8 respectively. Turn ON the pin for the input point to be set and make sure all the other pins are OFF. First we will set input point 1.



4. The offset is the lowest voltage or current that will be input. The Module will convert this value to 000 hexadecimal. Apply the desired offset to the terminals of input point 1. Flip SW 2 down to read in as 0 V or mA the current or voltage currently being applied to the input terminals. This input value will be stored as the offset, i.e., as zero.

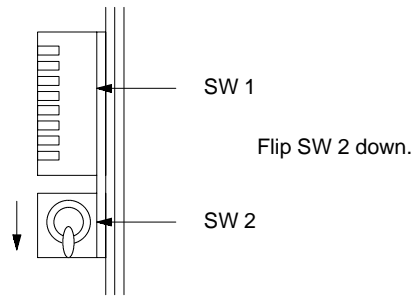

5. The gain is the highest voltage or current that will be input. The Module will convert this value to FFF hexadecimal. Apply the desired gain) to the terminals of input point 1. Flip SW 2 to down to read in as 10 V or 20 mA current or voltage currently being applied to the input terminals. The input value will be stored as the gain, i.e., as 10 V or 20 mA.

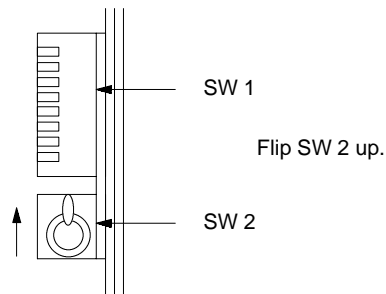

6. Continue on in this way to set the offset and gain for input points 2 through 8. Make sure you turn OFF each pin of SW 1 before you turn ON the next pin. Never allow more than one pin of SW 1 to be ON simultaneously. After you are finished setting all the input points, re-attach the front panel to the Module.



## 2-2 DA101 Analog Output Modules

The output range must be set for each input point using the DIP switches on the back of the Module. Each input point is set to 1 to 5 V at the factory, but double check the settings before use. Be sure to set these switches before mounting the Module, as they will not be accessible while the Module is mounted.

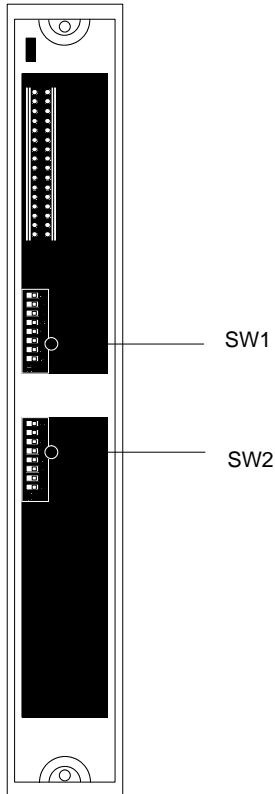

Back of Module

DIP switch	Port	Pin	Output range		
			0 to 10 V	1 to 5 V	4 to 20 mA
SW1	1	1	OFF	ON	ON
		2	OFF	ON	ON
		3	OFF	OFF	ON
		4	ON	OFF	OFF
	2	5	OFF	ON	ON
		6	OFF	ON	ON
		7	OFF	OFF	ON
		8	ON	OFF	OFF
SW2	3	1	OFF	ON	ON
		2	OFF	ON	ON
		3	OFF	OFF	ON
		4	ON	OFF	OFF
	4	5	OFF	ON	ON
		6	OFF	ON	ON
		7	OFF	OFF	ON
		8	ON	OFF	OFF

Set the pins to the appropriate positions for the output range you are going to use. The pins are set as shown below.

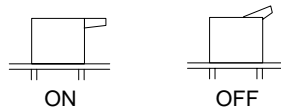



# SECTION 3

## Installation

This section provides the dimensions, wiring diagrams, and other information required to install the Analog I/O Modules. Be sure to set back-panel switches as required before mounting the Modules to the Racks.

3-1	AD001 through AD005 Analog Input Modules .....	12
3-1-1	Dimensions .....	12
3-1-2	Wiring .....	13
3-2	AD006 and AD007 Analog Input Modules .....	15
3-2-1	Dimensions .....	15
3-2-2	Wiring .....	16
3-3	AD101 Analog Input Modules .....	18
3-3-1	Dimensions .....	18
3-3-2	Wiring .....	18
3-4	DA001 through DA005 Analog Output Modules .....	21
3-4-1	Dimensions .....	21
3-4-2	Wiring .....	22
3-5	DA101 Analog Output Modules .....	24
3-5-1	Dimensions .....	24
3-5-2	Wiring .....	24

### 3-1 AD001 through AD005 Analog Input Modules

#### 3-1-1 Dimensions

All dimensions given below are in millimeters.

##### 3G2A5-AD001 through 3G2A5-AD005

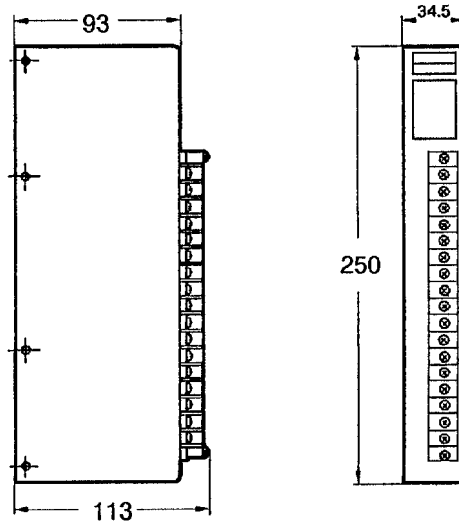

##### 3G2A6-AD001 through 3G2A6-AD005 (Mounted to 3G2C4-SIO25/SIO26)

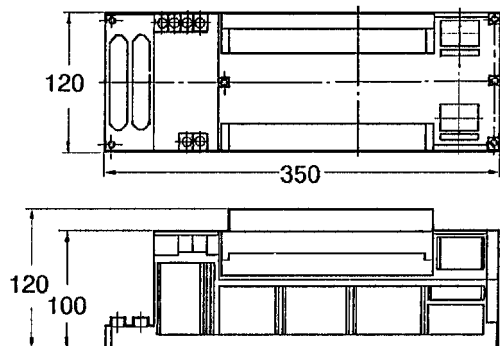

### 3-1-2 Wiring

Use shielded twisted-pair cable for external connections.

Connect the positive and negative terminals of any unused input points to the shield terminal.

Use separate power supplies for input points 1 and 2 whenever possible. When using separate power supplies, always connect the negative input terminal to the shield line; failure to do so will produce several percent of error in the converted data.

Incorrect wiring will produce inaccuracy in converted data. Use the proper wiring diagram and wire with care.

#### Voltage Inputs

VOLTAGE ONLY	
AD001	+1 ~ +5VDC
AD002	0 ~ +10VDC
AD003	0 ~ +5VDC
AD004	-10 ~ +10VDC
AD005	-5 ~ +5VDC

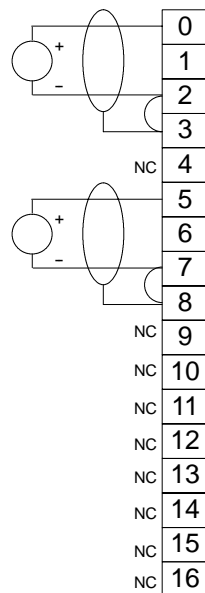

Current Inputs

AD001	+4 ~ +20mA
-------	------------

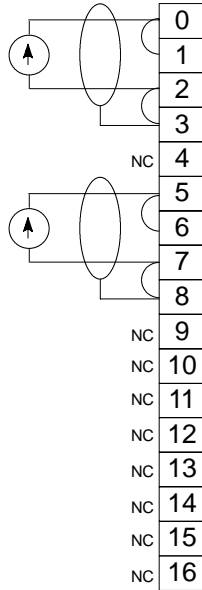

### 3-2 AD006 and AD007 Analog Input Modules

#### 3-2-1 Dimensions

All dimensions given below are in millimeters.

##### 3G2A5-AD006/AD007

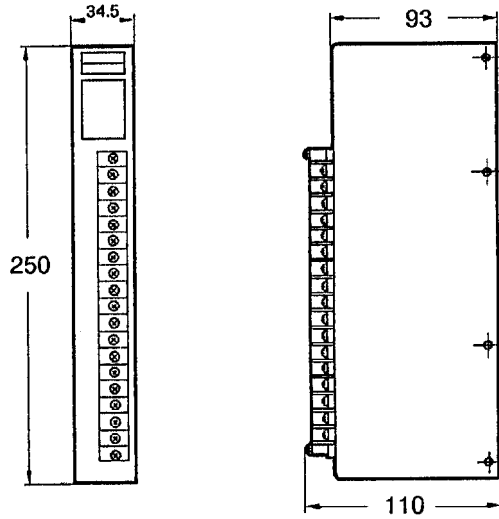

##### 3G2A6-AD006/AD007 (Mounted to 3G2C4-SIO25/SIO26)

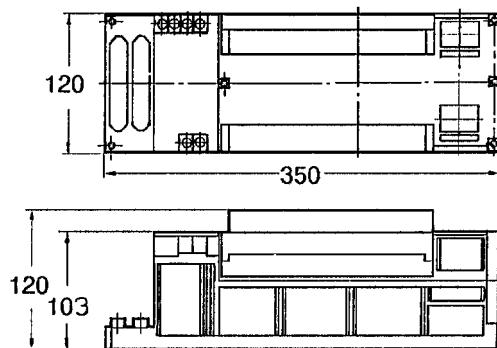

### 3-2-2 Wiring

#### Voltage Inputs

VOLTAGE ONLY	
AD006	+1 ~ +5VDC
AD007	0 ~ +10VDC

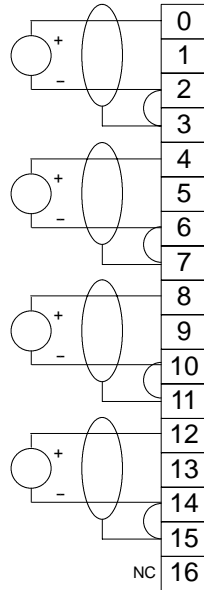



## Current Inputs

CURRENT ONLY	
AD006	4 ~ +20mA

## Wiring Notes

1. Use twisted-pair cable for external connections.
2. Connect the positive and negative terminals of any unused input points to the shield terminal.
3. For voltage inputs, connect the negative terminal to the shield terminal. Failure to do so may cause an error of several percent in the data.
4. For current inputs, Omron recommends that you use a separate power supply for each input point.

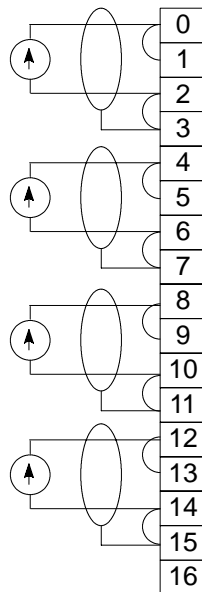

### 3-3 AD101 Analog Input Modules

#### 3-3-1 Dimensions

All dimensions given below are in millimeters.

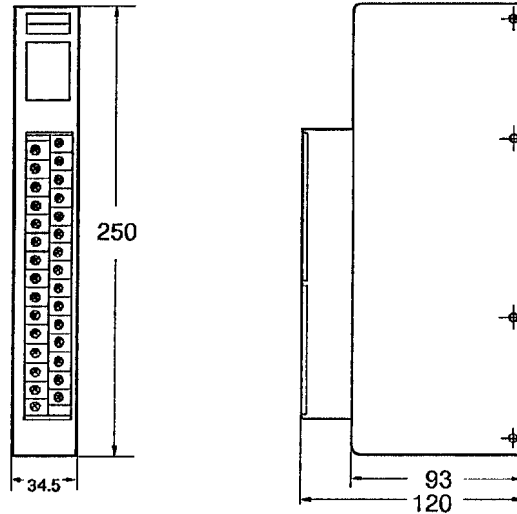

#### 3-3-2 Wiring

##### Terminal Allocations

Point 1	+ Voltage/current input 1	0	15	+ Voltage/current input 5	Point 5
	- Current input 1	1	16	- Current input 5	
	- Voltage/current input 1	2	17	- Voltage/current input 5	
Shield		3	18	Shield	
Point 2	+ Voltage/current input 2	4	19	+ Voltage/current input 6	Point 6
	- Current input 2	5	20	- Current input 6	
	- Voltage/current input 2	6	21	- Voltage/current input 6	
Not connected		7	22	Not connected	
Point 3	+ Voltage/current input 3	8	23	+ Voltage/current input 7	Point 7
	- Current input 3	9	24	- Current input 7	
	- Voltage/current input 3	10	25	- Voltage/current input 7	
Shield		11	26	Shield	
Point 4	+ Voltage/current input 4	12	27	+ Voltage/current input 8	Point 8
	- Current input 4	13	28	- Current input 8	
	- Voltage/current input 4	14	29	- Voltage/current input 8	

Voltage Input Connections

VOLTAGE ONLY	
AD101	0 ~ +10VDC Adjustable. (See note.)

**Note** Factory default is 0 ~ +5VDC.

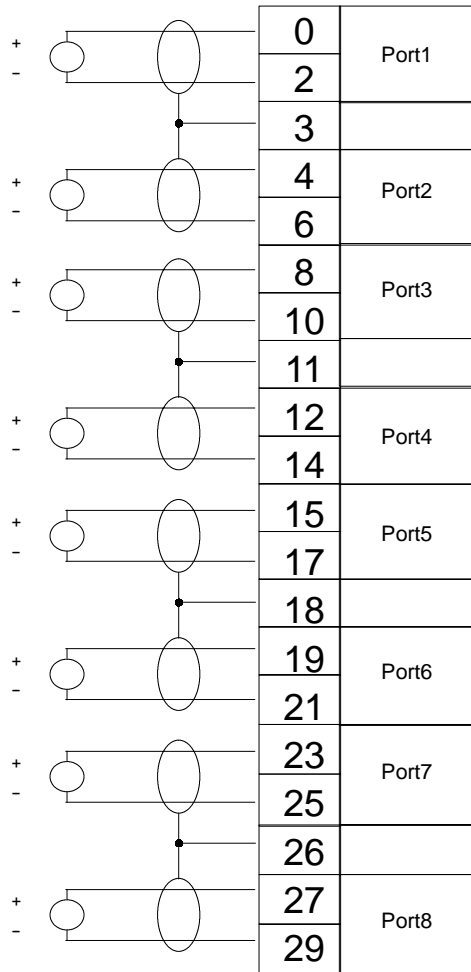

Current Input Connections

CURRENT ONLY	
AD101	0 ~ +20mA Adjustable. (See note.)

**Note** Factory default is 4 ~ 20mA.

**Wiring Notes**

1. Use shielded twisted-pair cable for external connections.
2. Connect the positive and negative terminals of any unused input points to the shield terminal.

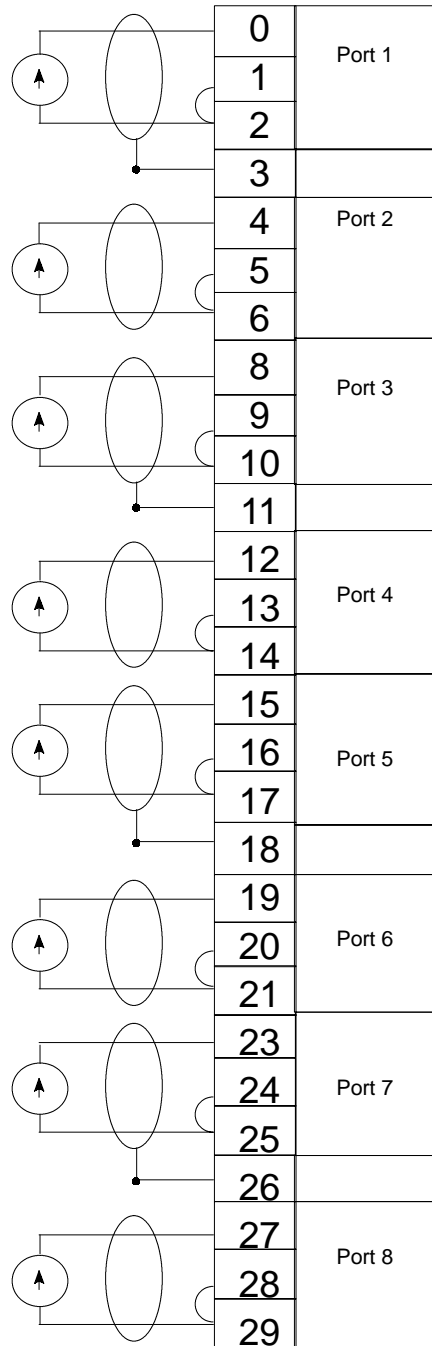

### 3-4 DA001 through DA005 Analog Output Modules

#### 3-4-1 Dimensions

All dimensions given below are in millimeters.

##### 3G2A5-DA001 through 3G2A5-DA005

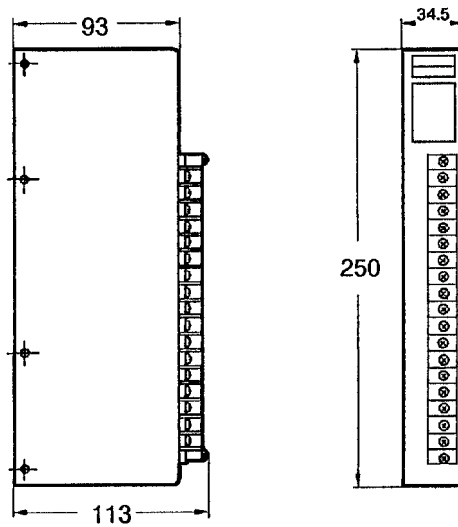

##### 3G2A6-DA001 through 3G2A6-DA005 (Mounted to 3G2C4-SIO25/SIO26)

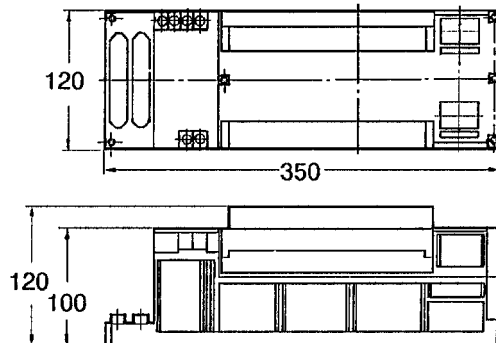

### 3-4-2 Wiring

#### Voltage Outputs

VOLTAGE ONLY	
DA001	+1 ~ +5VDC
DA002	0 ~ +10VDC
DA003	0 ~ +5VDC
DA004	-10 ~ +10VDC
DA005	-5 ~ +5VDC

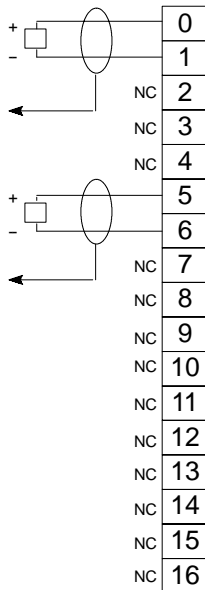

Current Outputs

CURRENT ONLY	
DA001	+4 ~ +20mA

Wiring Notes

1. Use 2-conductor shielded twisted-pair cable for external connections to prevent induction and noise.
2. Ground the shields to the Module.
3. Do not use the same cable for signal lines and AC wiring to external devices.
4. Do not run the Module's cables near or bind them together with main circuit cables or high voltage cables. Keep the external signal cables separate from AC cables.

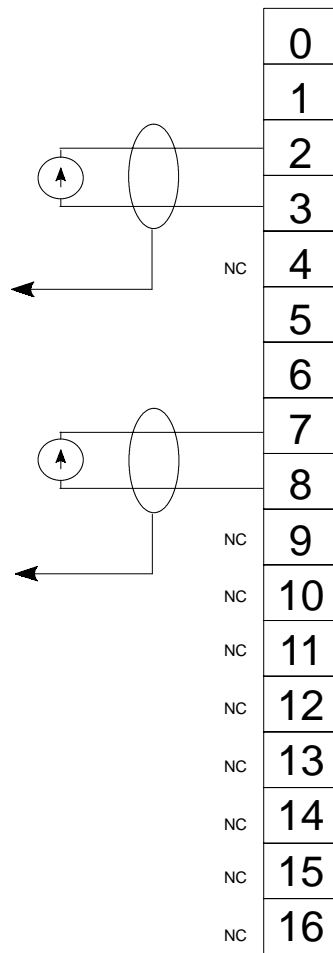

### 3-5 DA101 Analog Output Modules

#### 3-5-1 Dimensions

All dimensions given below are in millimeters.

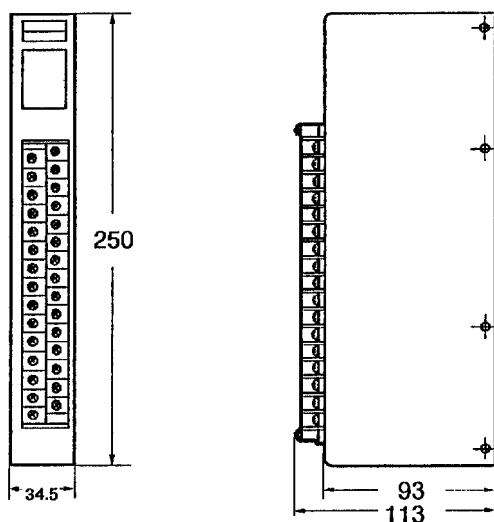

#### 3-5-2 Wiring

##### Terminal Allocations

Point	Output	Polarity	Terminal
1	Voltage output	+	0
		-	1
	Current output	+	2
		-	3
2	Voltage output	+	4
		-	5
	Current output	+	6
		-	7
3	Voltage output	+	8
		-	9
	Current output	+	10
		-	11
4	Voltage output	+	12
		-	13
	Current output	+	14
		-	15
Not used.			16



Voltage Output Connections

VOLTAGE ONLY	
DA101	0 ~ +10VDC
	+1 ~ +5VDC (See note.)

**Note** Factory default is +1 ~ +5VDC.

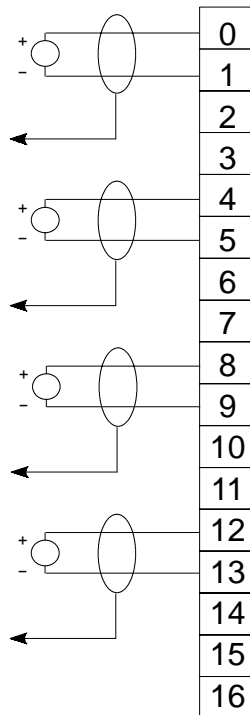

Current Output Connections

CURRENT ONLY	
DA101	+4 ~ +20mA

Wiring Notes

1. Use 2-conductor shielded twisted-pair cable for external connections to prevent induction and noise.
2. Ground the shields to the Module.
3. Do not use the same cable for signal lines and AC wiring to external devices.
4. Do not run the Module's cables near or bind them together with main circuit cables or high voltage cables. Keep the external signal cables separate from AC cables.

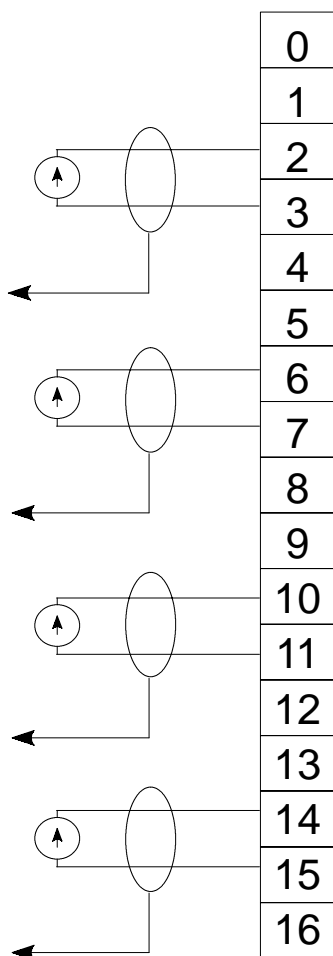

# SECTION 4

## Operation

This section describes the basic operation of the Analog I/O Modules, including A/D and D/A conversion methods and IR bit allocations and application.

4-1	AD001 through AD005 Analog Input Modules .....	28
4-1-1	Block Diagram .....	28
4-1-2	A/D Conversion .....	28
4-1-3	IR Bit Allocations .....	29
4-2	AD006 and AD007 Analog Input Modules .....	30
4-2-1	Block Diagram .....	30
4-2-2	A/D Conversion .....	30
4-2-3	IR Bit Allocations .....	31
4-3	AD101 Analog Input Modules .....	31
4-3-1	Block Diagram .....	32
4-3-2	A/D Conversion .....	32
4-3-3	Operational Flow .....	33
4-3-4	Two-word Operation .....	33
4-3-5	Four-word Operation .....	39
4-4	DA001 through DA005 Analog Output Modules .....	40
4-4-1	Block Diagram .....	41
4-4-2	D/A Conversion .....	41
4-4-3	IR Bit Allocations .....	43
4-5	DA101 Analog Output Modules .....	43
4-5-1	Block Diagram .....	44
4-5-2	D/A Conversion .....	44
4-5-3	Operational Flow .....	45
4-5-4	IR Bit Allocations .....	46

## 4-1 AD001 through AD005 Analog Input Modules

With the AD001 and AD005, the binary-converted value of each input point is input to a dedicated IR word, i.e., the contents of the IR word allocated to any one input point will always contain the value of the analog input at the most recent I/O refresh period. This data can be used directly in binary form or converted to BCD for further use.

This section describes the internal connections of the Module, the AD conversion method used, and the IR bit allocations. Refer to *Section 5 Programming Considerations* for programming examples.

### 4-1-1 Block Diagram

The following diagram shows the basic internal connections of the Module.

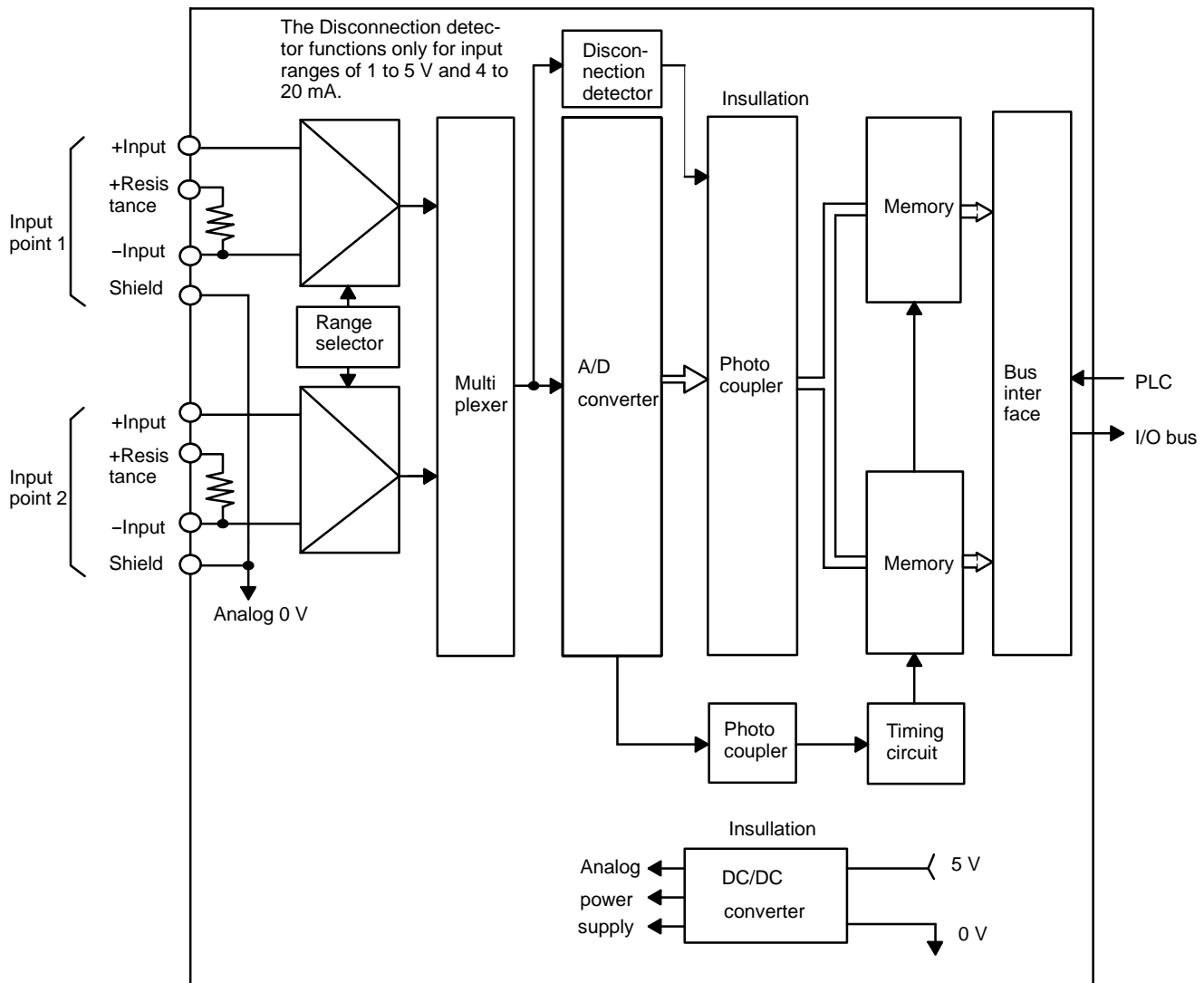

### 4-1-2 A/D Conversion

The analog inputs are converted to 12-bit binary code. Five different conversion ranges are available, 0 to 10 V, 0 to 5 V, 1 to 5 V (4 to 20 mA), -5 to 5 V, or -10 to 10 V, depending on the model of the Module. The relationships between the analog input values and converted binary values are shown next.

**Positive Ranges**

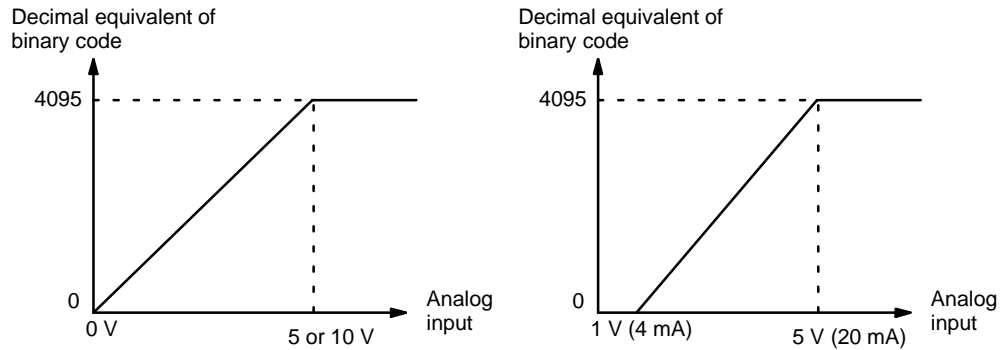

**Positive/Negative Ranges**

Positive and negative values are differentiated via bit 11 (see below).

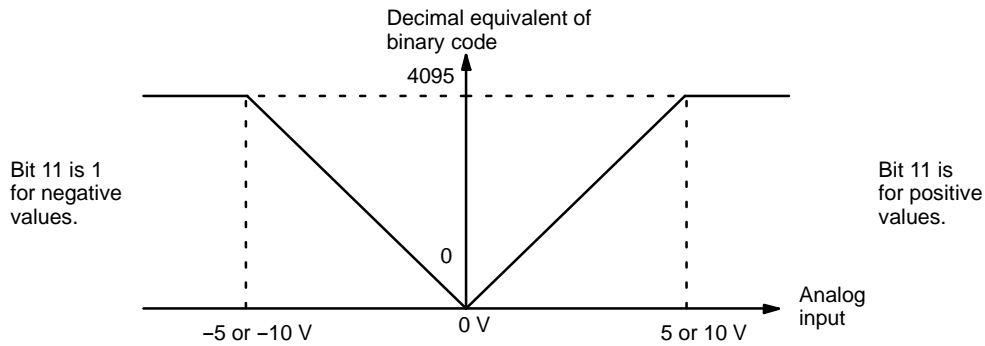

**4-1-3 IR Bit Allocations**

Bits in words IR n and IR n+1 are allocated as shown below.

Bit 11 provides  $2^{11}$  data for ranges with only positive values, but operates as the Sign Flag for input ranges that include negative values. The Sign Flag will be 0 for positive values and 1 for negative values.

Bit 15 is the Disconnection Flag for input ranges of 1 to 5 V and 4 to 20 mA, and will be 1 when a voltage of 0.5 V or less is detected for 1 to 5 V or when a current of 2 mA or less is detected for 4 to 20 mA.

Bit	Input words	
	IR n: point 1	IR n+1: point 2
0	A/D converted data $2^0$	A/D converted data $2^0$
1	A/D converted data $2^1$	A/D converted data $2^1$
2	A/D converted data $2^2$	A/D converted data $2^2$
3	A/D converted data $2^3$	A/D converted data $2^3$
4	A/D converted data $2^4$	A/D converted data $2^4$
5	A/D converted data $2^5$	A/D converted data $2^5$
6	A/D converted data $2^6$	A/D converted data $2^6$
7	A/D converted data $2^7$	A/D converted data $2^7$
8	A/D converted data $2^8$	A/D converted data $2^8$
9	A/D converted data $2^9$	A/D converted data $2^9$
10	A/D converted data $2^{10}$	A/D converted data $2^{10}$
11	A/D converted data $2^{11}$ or Sign Flag	A/D converted data $2^{11}$ or Sign Flag
12 to 14	0	0
15	Disconnection Flag	Disconnection Flag

## 4-2 AD006 and AD007 Analog Input Modules

With the AD006 and AD007, the binary-converted value of each input point is input to a dedicated IR word, i.e., the contents of the IR word allocated to any one input point will always contain the value of the analog input at the most recent I/O refresh period. This data can be used directly in binary form or converted to BCD for further use.

This section describes the internal connections of the Module, the AD conversion method used, and the IR bit allocations. Refer to *Section 4 Programming Considerations* for programming examples.

### 4-2-1 Block Diagram

The following diagram shows the basic internal connections of the Module.

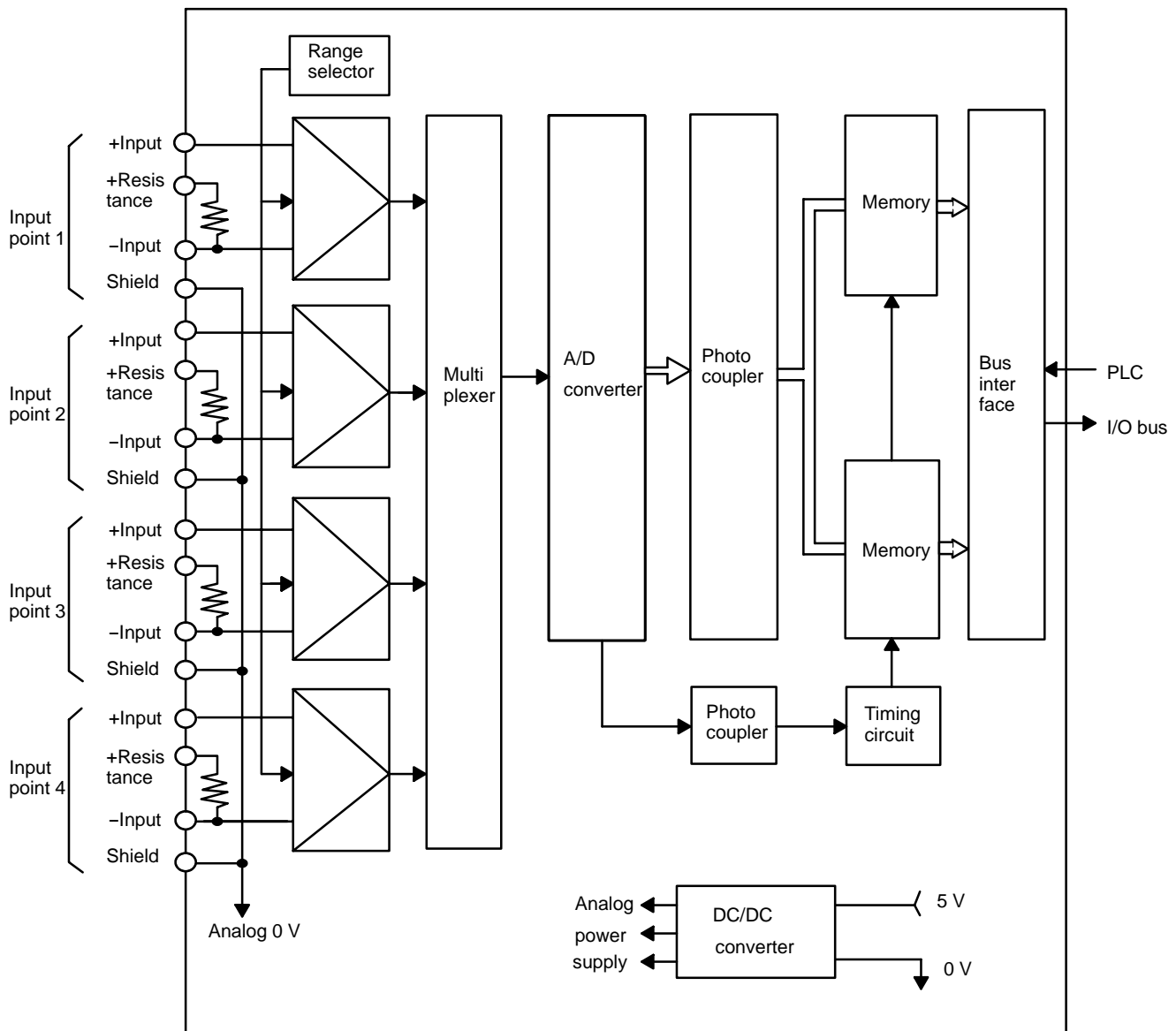

### 4-2-2 A/D Conversion

The analog inputs are converted to 10-bit binary code. Two different conversion ranges are available, 0 to 10 V or 1 to 5 V (4 to 20 mA), depending on

the model of the Module. The relationships between the analog input values and converted binary value are shown below.

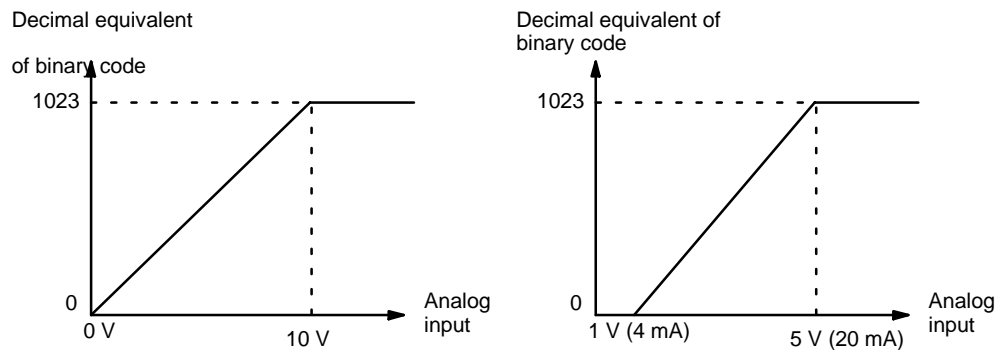

### 4-2-3 IR Bit Allocations

Bit	Input words			
	IR n: point 1	IR n+1: point 2	IR n+2: point 3	IR n+3: point 4
0	A/D converted data $2^0$	A/D converted data $2^0$	A/D converted data $2^0$	A/D converted data $2^0$
1	A/D converted data $2^1$	A/D converted data $2^1$	A/D converted data $2^1$	A/D converted data $2^1$
2	A/D converted data $2^2$	A/D converted data $2^2$	A/D converted data $2^2$	A/D converted data $2^2$
3	A/D converted data $2^3$	A/D converted data $2^3$	A/D converted data $2^3$	A/D converted data $2^3$
4	A/D converted data $2^4$	A/D converted data $2^4$	A/D converted data $2^4$	A/D converted data $2^4$
5	A/D converted data $2^5$	A/D converted data $2^5$	A/D converted data $2^5$	A/D converted data $2^5$
6	A/D converted data $2^6$	A/D converted data $2^6$	A/D converted data $2^6$	A/D converted data $2^6$
7	A/D converted data $2^7$	A/D converted data $2^7$	A/D converted data $2^7$	A/D converted data $2^7$
8	A/D converted data $2^8$	A/D converted data $2^8$	A/D converted data $2^8$	A/D converted data $2^8$
9	A/D converted data $2^9$	A/D converted data $2^9$	A/D converted data $2^9$	A/D converted data $2^9$
10 to 15	0	0	0	0

## 4-3 AD101 Analog Input Modules

There are two modes of operation available with the AD101: two-word operation and four-word operation. Although the method for reading in analog values varies depending on the operation mode, the binary-converted value of each input point is input into the PLC in binary form. This data can be used directly in binary form or converted to BCD for further use.

This section describes the internal connections of the Module, the AD conversion method used, the IR bit allocations, the methods used to input analog values, and special functions available. Refer to *Section 4 Programming Considerations* for programming examples.

### 4-3-1 Block Diagram

The following diagram shows the basic internal connections of the Module.

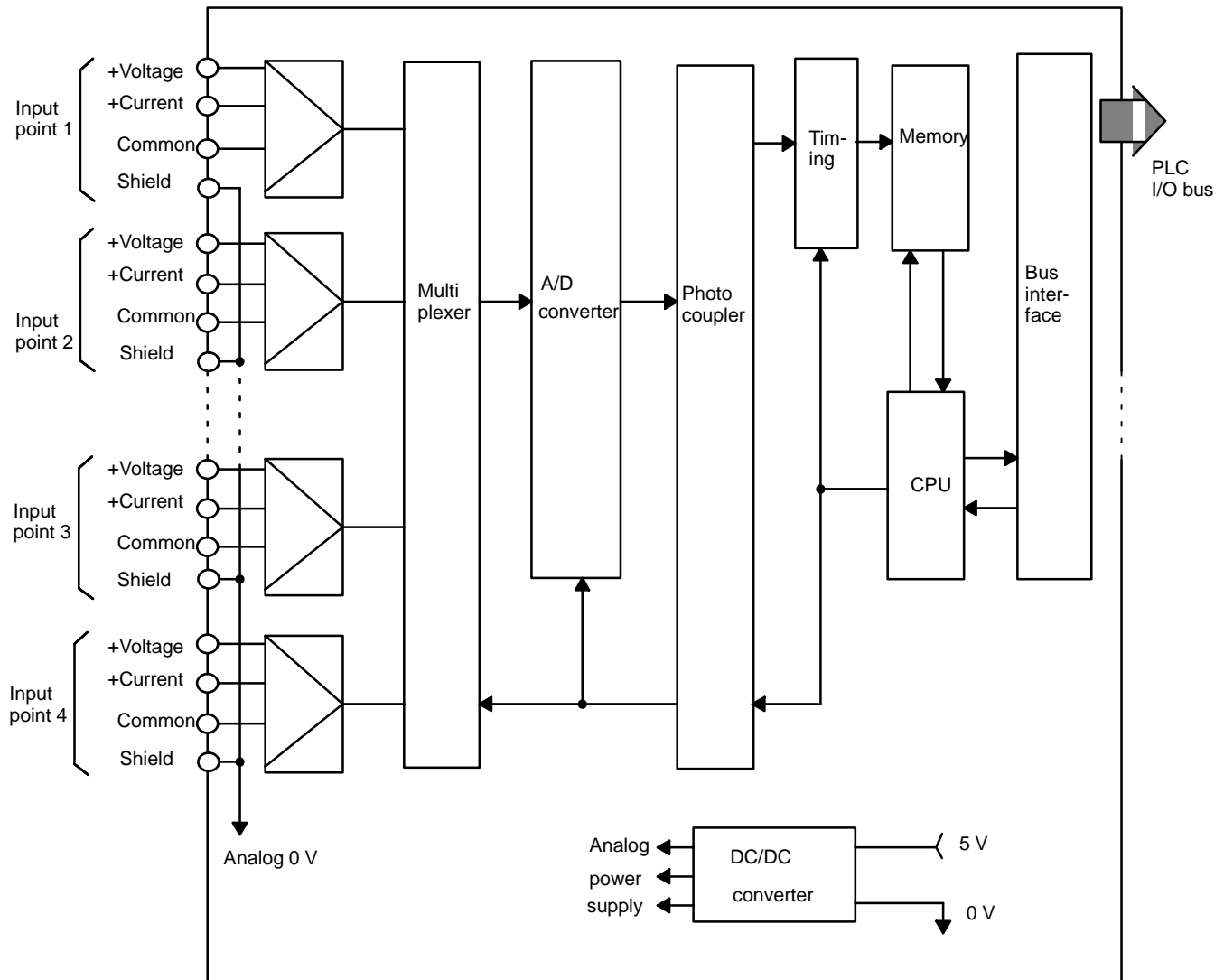

### 4-3-2 A/D Conversion

Analog input values are converted to binary according to the offset and gain values set for the input (most binary values are given in hexadecimal in this manual). Line (1) in the following figures shows the factory settings, 1 to 5 V (4 to 20 mA). This means that an input of 1 V (4 mA) will be converted to  $000_{\text{hex}}$  and an input of 5 V (20 mA) will be converted to  $FFF_{\text{hex}}$ .

The maximum ranges, 0 to 10 V (0 to 20 mA), are shown by line (2) in the figures. The offset and gain for any input point can be set anywhere within these ranges as long as the gain is greater than the offset: the offset value is always converted to  $000_{\text{hex}}$ , and the gain is always converted to  $FFF_{\text{hex}}$ .



The relationships between the input analog values and the converted binary values are shown below. Binary values are given in their hexadecimal equivalents.

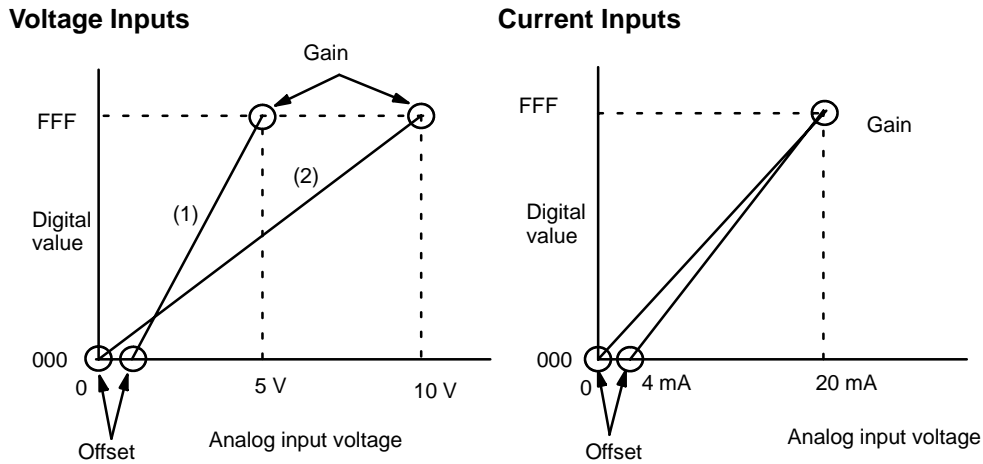

### 4-3-3 Operational Flow

The basic steps involved in setting up and operating the AD101 are shown below. Some of these steps have already been described in this manual.

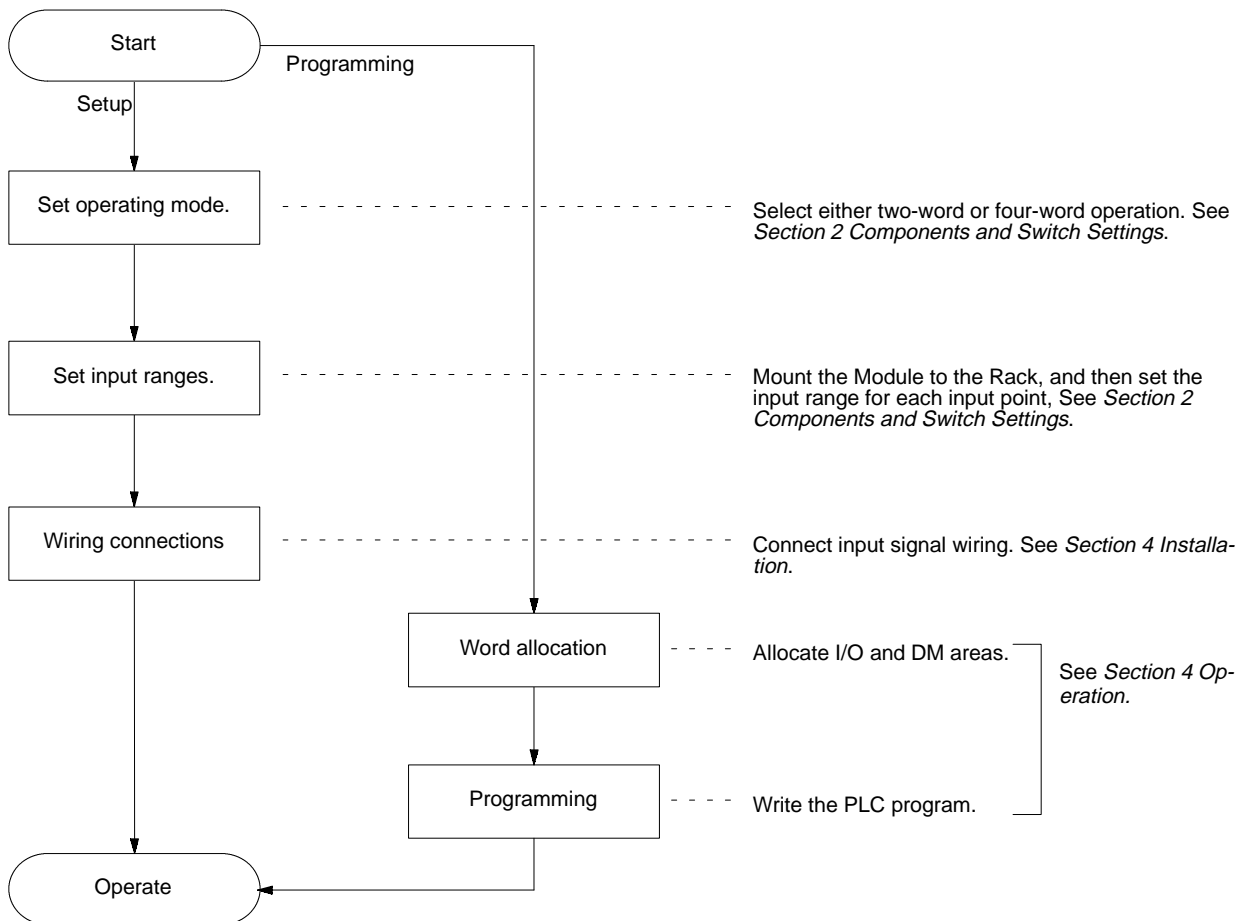

### 4-3-4 Two-word Operation

In two-word operation, there are two types of data transfer that occurs between the Analog Input Module and the PLC. One of these uses the normal

I/O refresh period to transfer flag and control bit status (see *IR Bit Allocations* below) between the Analog Input Module and the IR words allocated to the Module. Here, the output word (IR n) is used to designate when peak value for input points are to be read or reset and the input word (IR n+1) is used to confirm data validity and to check when peak values are being read.

The other form of data transfer is used to write parameters (e.g., offsets and gains) directly to the Analog Input Module or to read data (i.e., binary-converted analog values or peak values) directly from the Module. In this case the input and output words are used as the operands for the I/O WRITE and I/O READ instructions, WRIT(87) and READ(88). The data being read or written is stored at consecutive words beginning at a word designated as another operand. The general forms of these instructions are shown below. Refer to your PLC's *Operation Manual* for details.

**I/O WRITE Instruction**

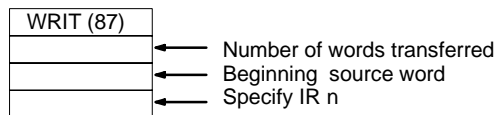

**I/O READ Instruction**

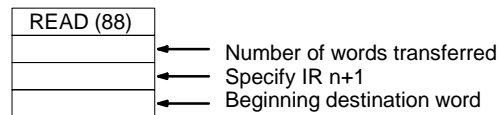

**Communications**

The following diagram illustrated communications between the AD101 Analog Input Module and the PLC during two-word operation. The I/O READ and I/O WRITE instructions are used to directly read and write data. Refer to the next page for details on IR n and IR n+1.

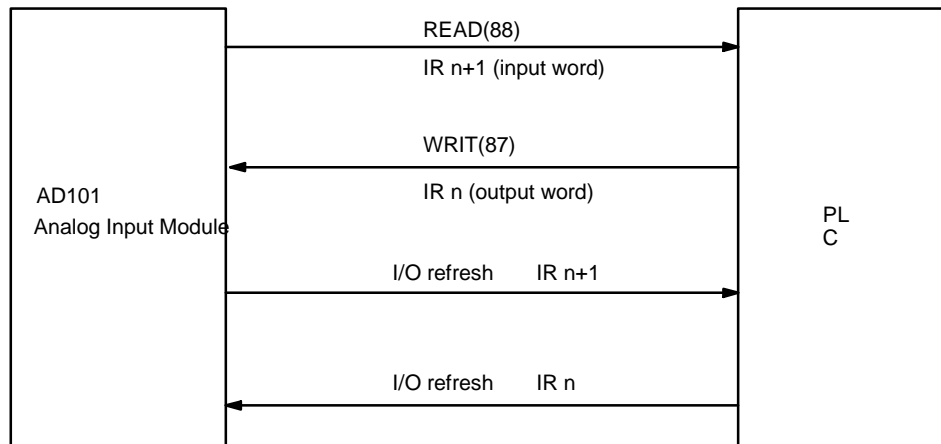

**IR Bit Allocations**

The following bits are used to control data transfer between the Analog Input Module and the PLC as explained below the table. The first three bits in each word are system handshaking flags, bit 03 of n+1 is used to confirm data,

and the other bits are used to control and monitor reading of peak input values.

Bit	Ouput word: IR n	Input word: IR n+1
00	(PC Busy Flag)	(A/D Busy Flag)
01	(PC Write Finished Flag)	(A/D Read Finish Flag)
02	(PC Read Finished Flag)	(A/D Write Finish Flag)
03	Not used.	Unconfirmed Data Flag
04 to 06	Not used.	Not used.
07	Peak Reset Bit	Not used.
08	Peak Read Bit 0	Peak Flag 0
09	Peak Read Bit 1	Peak Flag 1
10	Peak Read Bit 2	Peak Flag 2
11	Peak Read Bit 3	Peak Flag 3
12	Peak Read Bit 4	Peak Flag 4
13	Peak Read Bit 5	Peak Flag 5
14	Peak Read Bit 6	Peak Flag 6
15	Peak Read Bit 7	Peak Flag 7

#### Handshaking Flags

Bits 00 through 02 of both the input and output words are system handshaking flags and cannot be used in programming. The status of these bits determines whether or not the I/O READ and I/O WRITE instructions will be executed as desired (see *Reading Data* and *Writing Data* below).

#### Unconfirmed Data Flag

This bit turns ON when data has not been confirmed (for example, when the power has just been turned on). Be sure this flag is OFF before reading data.

#### Peak Reset Bit

This bit is turned ON with one or more of the Peak Read Bits to reset the peak values of the input points designated by the Peak Read Bit.

#### Peak Read Bits

If the Peak Reset Bit is OFF, these bits are turned ON to read the peak values. The peak value for each ON bit will be read in the next time READ(88) is executed for the input word. If the Peak Read Bit is turned ON for an input point, the data read with the next READ(88) will be the peak value; if the Peak Read Bit is turned OFF for a point, the data read with the next READ(88) will be the normal input value. Here, however, "the next READ(88)" is the next one following the next I/O refresh period. The Peak Flags can be used to check to see whether peak values have been reached.

The Peak Read Bits are also used with the Peak Reset Bit to reset the peak values.

#### Peak Flags

The Peak Flags turn ON to indicate that the input value for the input point has reached a peak value. input points for which peak values have been read instead of normal input values.

### Writing Data

WRIT(87) is used to transfer operating parameter directly to the Analog I/O Module and is executed only when both the A/D Busy Flag (IR n+1, bit 00) and A/D Read Finished Flag (IR n+1, bit 01) are OFF. If either of these flags is ON when WRIT(87) is reached in the program, WRIT(87) will be executed as NOP. After WRIT(87) has been executed, the PC Write Finished Flag (IR n, bit 01) will turn ON for one scan and the Equals flag ( SR 6306 or SR 25506) will turn ON.

**Data Writing Area**

WRIT(87), is used to transfer a maximum of 26 words of data to the Analog Input Module. The first word, m, is specified by the user and written as the beginning source word of WRIT(87). All consecutive words must be in the same data area (DM m through DM m+25).

The first two words are used to specify which points will be used and which points the mean and scaling functions will be used for. If the mean or scaling values are not required for an input point, no data need be provided, i.e., you need to transfer only the data that is actually required for operation as specified in the first two words. If not all of the data is required, fewer words will need to be transferred.

DM word	Bit															
	15	14	13	12	11	10	9	8	7	6	5	4	3	2	1	0
DM m	Specify points for mean function								Specify points to be used							
DM m+1	Specify points for scaling function								0				0			
DM m+2	Mean value 1															
DM m+3	Mean value 2															
DM m+4	Mean value 3															
DM m+5	Mean value 4															
DM m+6	Mean value 5															
DM m+7	Mean value 6															
DM m+8	Mean value 7															
DM m+9	Mean value 8															
DM m+10	Scaling offset 1															
DM m+11	Scaling gain 1															
DM m+12	Scaling offset 2															
DM m+13	Scaling gain 2															
DM m+14	Scaling offset 3															
DM m+15	Scaling gain 3															
DM m+16	Scaling offset 4															
DM m+17	Scaling gain 4															
DM m+18	Scaling offset 5															
DM m+19	Scaling gain 5															
DM m+20	Scaling offset 6															
DM m+21	Scaling gain 6															
DM m+22	Scaling offset 7															
DM m+23	Scaling gain 7															
DM m+24	Scaling offset 8															
DM m+25	Scaling gain 8															

**Caution** Input the mean value and scaling values only for points for which the mean and/or scaling function has been designated. If one of these is not needed for a point, move all other parameters up one word to replace it. For example, if a mean value is not required for input point 3 but is required for points 1, 2, and 4, the mean value for point 4 would be placed in DM m+ 04 instead of DM m+5.

**Point Specification**

If a point is to be used, turn the corresponding bit ON. If a point is not to be used, turn the corresponding bit OFF.

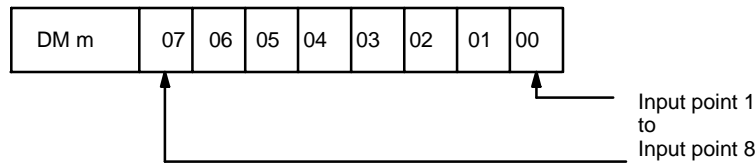

**Mean Value Specification**

If mean for an input point is to be used, turn the corresponding bit ON. If mean is not to be used, turn the corresponding bit OFF.

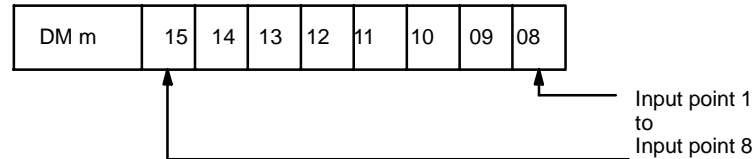

Specify the sampling count (2 through 9999) for the mean value. Enter data for each point specified for the mean function. Data must be specified in BCD. The actual words where data will need to be stored will depend on the actual data required.

If a large count is set, the conversion time may exceed the 10-ms-per-point conversion time by 1 or 2 ms.

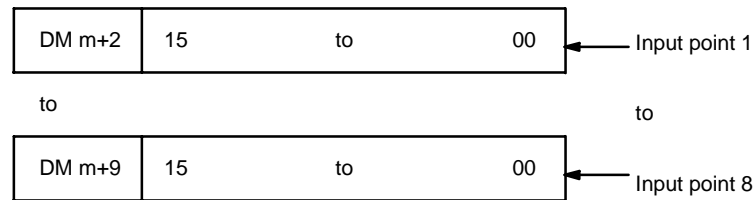

**Scaling**

If scaling is to be used for an input point, turn the corresponding bit ON. If scaling is not to be used, turn the corresponding bit OFF.

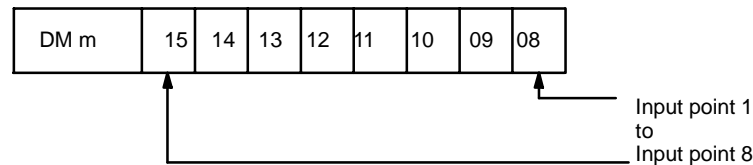

Enter the offset and gain for each point for which the scaling function has been designated. The offset is the value that is to correspond to 000<sub>hex</sub>. The gain is the value corresponding to FFF<sub>hex</sub>. The offset and gain must be set in BCD and must be in the range 0 through 9999. The gain must be greater than the offset.

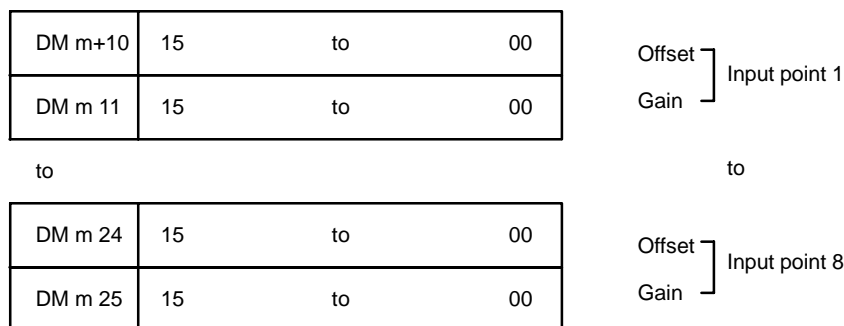

**Reading Data**

READ(88) will be executed when the A/D Busy Flag (IR n+1, bit 00) is OFF and the A/D Write Finished Flag (IR n+1, bit 02) is ON. If the A/D Busy Flag is ON or the A/D Write Finished Flag is OFF, READ(88) will not be executed.

The data transferred for READ(88) depends on the status of the Peak Read Bits, i.e., if the Peak Read Bit for an input is ON, the peak value will be transferred; if the Peak Read Bit is OFF, the normal binary-converted value will be transferred. The Peak Flags can be used to confirm what data has been transferred. The last word transferred always contains the Disconnection Flags.

**Data Reading Area**

READ(88) is used to transfer a maximum of 9 words of data beginning from DM I. The first word, I, is specified by the user and written as the beginning destination word of READ(88). You can select any area of DM as long as the end of the area is not exceeded (DM I through DM I+8).

DM word	Bit															
	15	14	13	12	11	10	9	8	7	6	5	4	3	2	1	0
DM I	Input point 1 converted data															
DM I+1	Input point 2 converted data															
DM I+2	Input point 3 converted data															
DM I+3	Input point 4 converted data															
DM I+4	Input point 5 converted data															
DM I+5	Input point 6 converted data															
DM I+6	Input point 7 converted data															
DM I+7	Input point 8 converted data															
DM I+8	0				0				Disconnection Flags							

**Note** Do not allocate the same area for both writing and reading data.

**Input Point Converted Data** A/D converted data is written to the specified words. When scaling is used, data is in 4-bit BCD (bits 00 to 15). When scaling is not used, data is in 3-bit hexadecimal (bits 00 to 11).

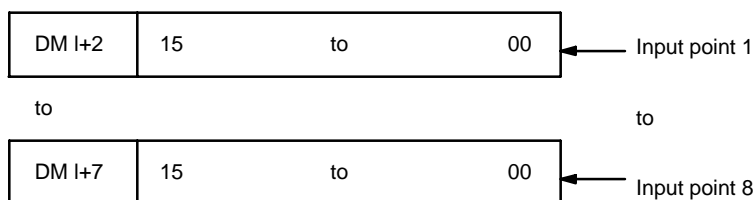

**Disconnection Flags**

When an input line disconnection is detected, the flag assigned to the input point will turn ON. The offset value must be at least 1 V (1 mA) for these flags to work.

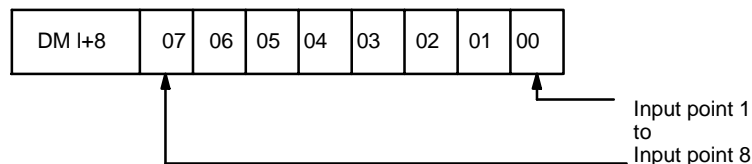

### 4-3-5 Four-word Operation

With four-word operation, IR n and IR n+2 are used as dedicated output and input words, respectively. IR n+1 is used to control data transfer and IR n+3 is used to monitor data transfer.

To write data, move the desired data to IR n and then set the proper control bits to designate what data has been set. The data will be read in at the next I/O refresh period. To read data, set the proper control bits and then move the data input to IR n+2 to the desired storage location after checking the flags to confirm that the desired data has been input.

Individual control bits and flags are described following the allocations table below.

#### IR Bit Allocations

Bit	Output		Input	
	IR n	IR n+1	IR n+2	IR n+3
00	Writing data	Point 1 Control Bit	Reading data	Point 1 Read Flag
01		Point 2 Control Bit		Point 2 Read Flag
02		Point 3 Control Bit		Point 3 Read Flag
03		Point 4 Control Bit		Point 4 Read Flag
04		Point 5 Control Bit		Point 5 Read Flag
05		Point 6 Control Bit		Point 6 Read Flag
06		Point 7 Control Bit		Point 7 Read Flag
07		Point 8 Control Bit		Point 8 Read Flag
08		Normal/Peak Control Bit		Disconnection Flag
09		Not used.	Normal/Peak Flag	
10			Not used.	
11				
12		Peak Reset Bit		Not used.
13		A/D Conversion Bit		
14		PC Write Completed Bit	A/D Read Completed Flag	
15	PC Read Completed Bit	A/D Write Completed Flag		

#### Point Control Bits

Turn ON one of the Point Control Bits to designate the desired input point when writing the number of sampling counts for the mean value and when reading binary-converted data. When using peak hold, turn the A/D Conversion Bit OFF. When not using peak hold, turn this flag ON.

#### Normal/Peak Control Bit

Turn this flag and the A/D Conversion Bit ON to read normal binary-converted values and turn this flag and the A/D Conversion Bit OFF to read peak values.

#### Peak Reset Bit

Turn this bit ON to reset an input point for which the peak value is being read.

#### A/D Conversion Bit

Turn this flag ON when reading normal data, and turn it OFF when reading peak values or writing the number of sampling counts for the mean value.

#### Point Read Flags

One of these flags turns ON to designate the input point for which data is being read.

#### Disconnection Flag

When the signal line of the point designated by the Point Read Flags is burned out or disconnected, this flag turns ON. The offset must be set to at least 1 V (4 mA) for this flag to work.

**Normal/Peak Flag**

This flag turns ON when the data being read is normal data and turns OFF when the data is the peak value.

**Mean Function**

If the both the Normal/Peak Control Bit and the A/D Conversion Bit are turned OFF, the value in IR n will be read in as the sampling count for the mean value for the input point specified by the Point Control Bits. Specify the sampling count (2 through 9999) for the mean value. Set the count to 0 to turn OFF the mean function for that point. Data must be specified in BCD.

**Note** The scaling function does not work with 4-word operation.

## 4-4 DA001 through DA005 Analog Output Modules

With the DA001 through DA005, the binary-converted value for each output point is placed in a dedicated IR word, i.e., the contents of the IR word allocated to any one output point contains the value of to be converted for output as an analog value.

This section describes the internal connections of the Module, the AD conversion method used, and the IR bit allocations. Refer to *Section 4 Programming Considerations* for programming examples.



### 4-4-1 Block Diagram

The following diagram shows the basic internal connections of the Module.

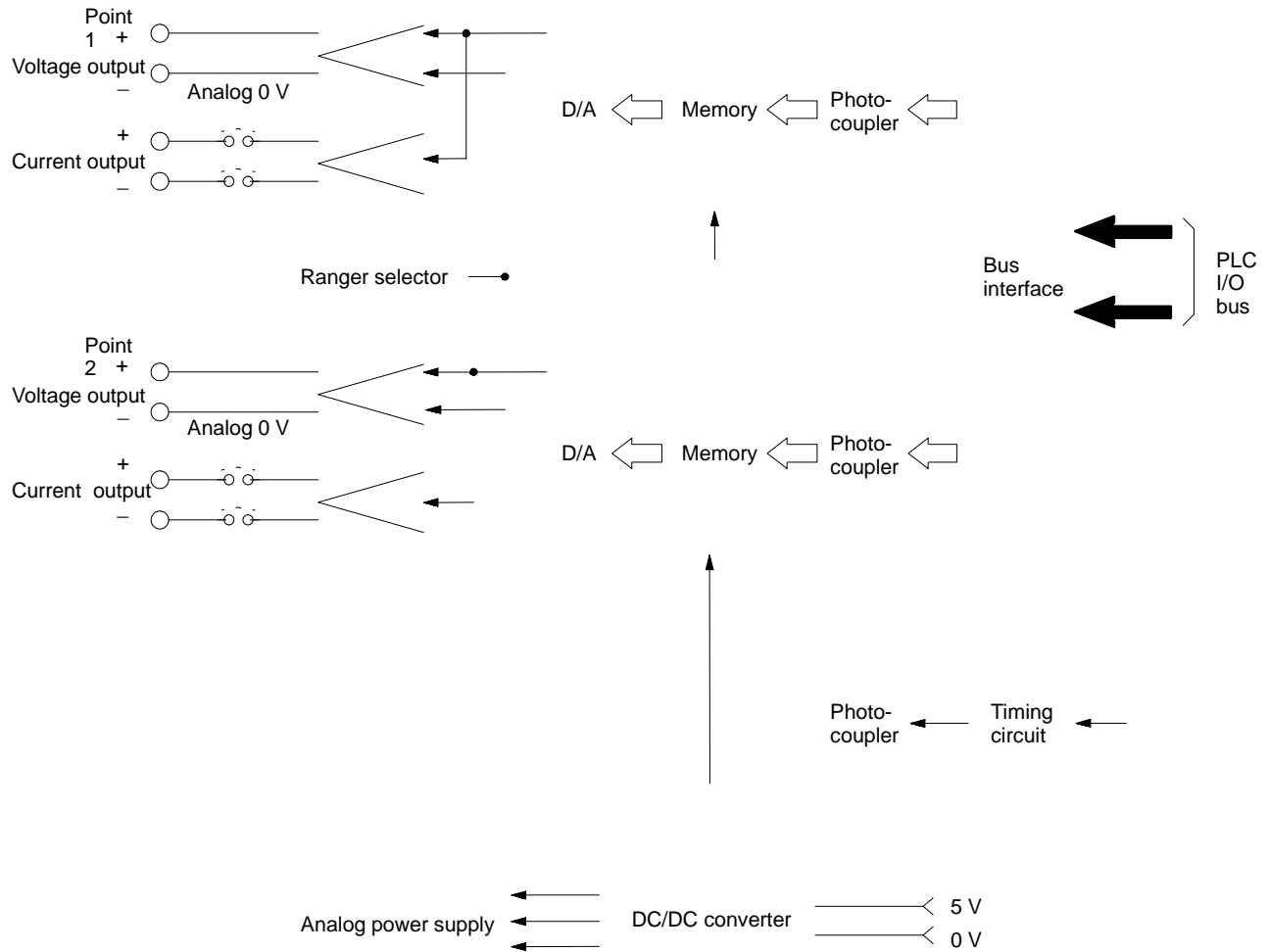

The current outputs are not connected in Modules whose voltage output range is other than 1 to 5 V.

### 4-4-2 D/A Conversion

These Modules convert 12-bit binary data to voltage or current output. Each Module has a different type of output. Outputs can be either unipolar or bipolar, with the resolution depending on the model.

#### Unipolar Outputs

Output ranges: 0 to 10 V, 0 to 5 V, or 1 to 5 V (4 to 20 mA)

Data format: 12-bit binary

Data conversion for unipolar outputs is illustrated below.

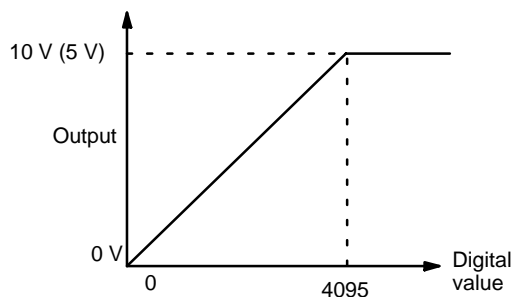

0 to 10 V Output or 0 to 5 V Outputs

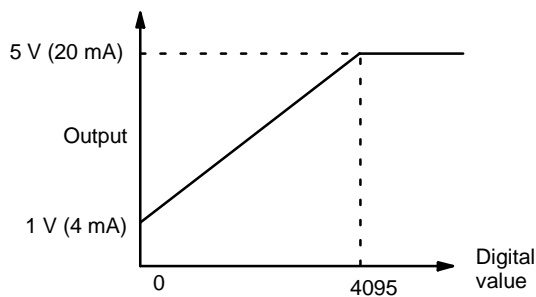

1 to 5 V (4 to 20 mA) Outputs

**Bipolar Output**

Output range: -10 to 10 V, -5 to 5 V

Data format: 11-bit binary +1 Sign Flag (The Sign Flag is bit 11; OFF is positive, ON is negative.)

Data conversion for bipolar outputs is illustrated below.

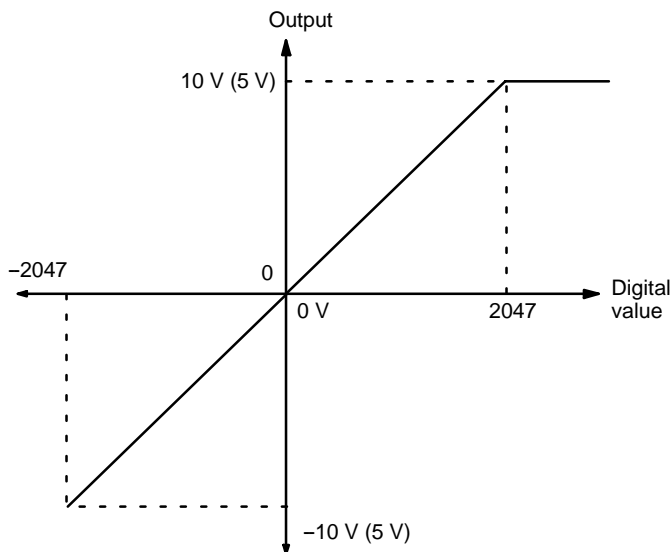

**Note:** The numbers 2048 to 4095 represent the values -0 to -2047.

### 4-4-3 IR Bit Allocations

Bit allocations of the words that contain the values that will be converted to analog values for output from each output point on the Analog Output Module are shown below.

Bit	Output words	
	IR n: Point 1	IR n+1: Point 2
0	D/A conversion data $2^0$	D/A conversion data $2^0$
1	D/A conversion data $2^1$	D/A conversion data $2^1$
2	D/A conversion data $2^2$	D/A conversion data $2^2$
3	D/A conversion data $2^3$	D/A conversion data $2^3$
4	D/A conversion data $2^4$	D/A conversion data $2^4$
5	D/A conversion data $2^5$	D/A conversion data $2^5$
6	D/A conversion data $2^6$	D/A conversion data $2^6$
7	D/A conversion data $2^7$	D/A conversion data $2^7$
9	D/A conversion data $2^9$	D/A conversion data $2^9$
10	D/A conversion data $2^{10}$	D/A conversion data $2^{10}$
11	D/A conversion data $2^{11}$ or Sign Flag	D/A conversion data $2^{11}$ or Sign Flag
12 to 15	Usable as work bits.	Usable as work bits.

**Note** For bipolar outputs, bit 11 is OFF for positive output values and ON for negative output values.

## 4-5 DA101 Analog Output Modules

With the DA101, the binary-converted value for each output point is placed in a dedicated IR word, i.e., the contents of the IR word allocated to any one output point contains the value of to be converted for output as an analog value.

This section describes the internal connections of the Module, the AD conversion method used, and the IR bit allocations. Refer to *Section 4 Programming Considerations* for programming examples.

### 4-5-1 Block Diagram

The following diagram shows the basic internal connections of the Module.

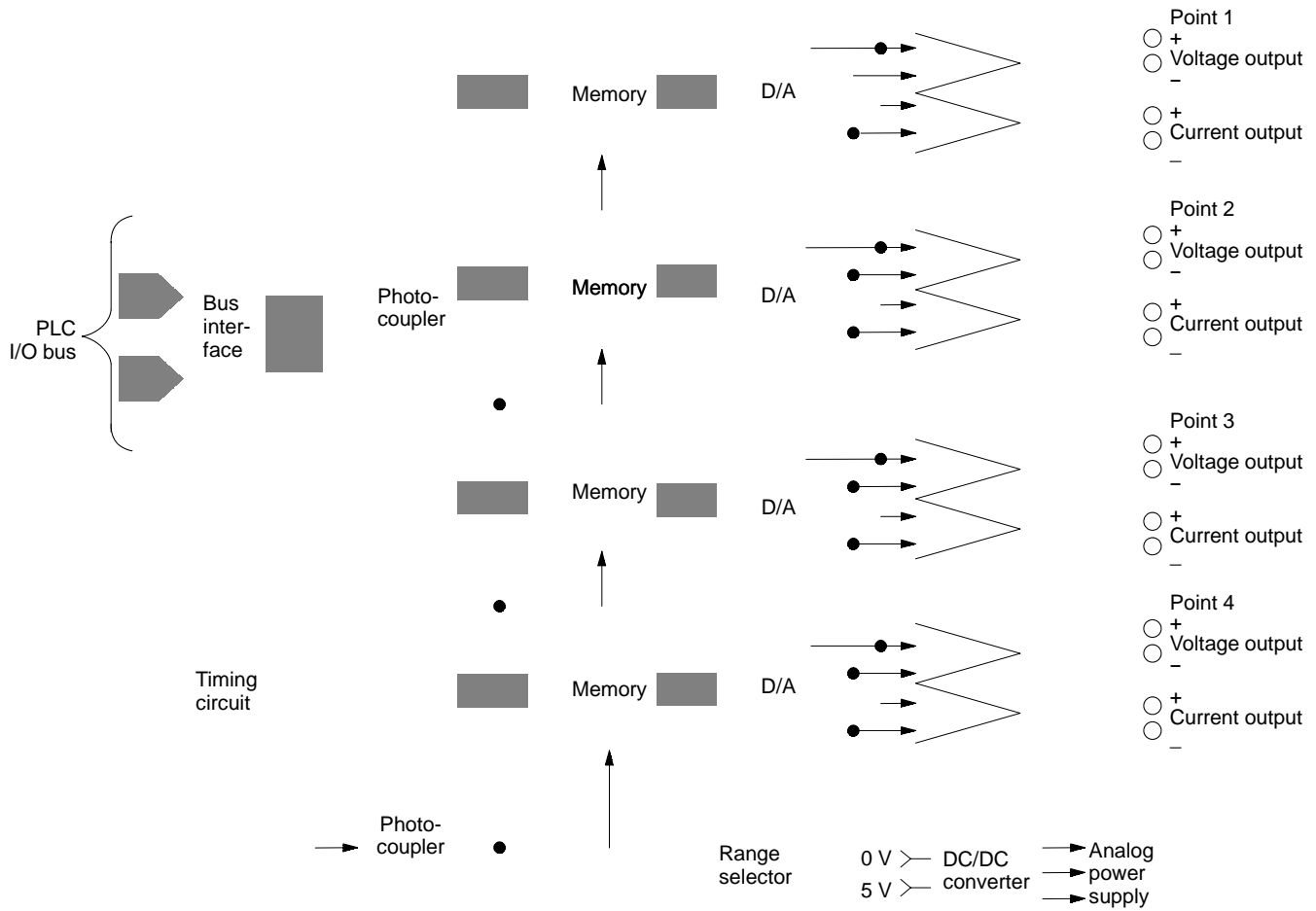

### 4-5-2 D/A Conversion

This Module converts 3-digit hexadecimal values (000 to FFF) from the specified words (IR n to n+3) for output from the Analog Output Module. The output range depends on the setting of the DIP switches (see *Section 2 Components and Switch Settings*).

The following diagram shows the basic flow of data from some PLC memory area, to the IR words allocated to the Analog Outputs Module, to the Module itself, and finally to the external device.

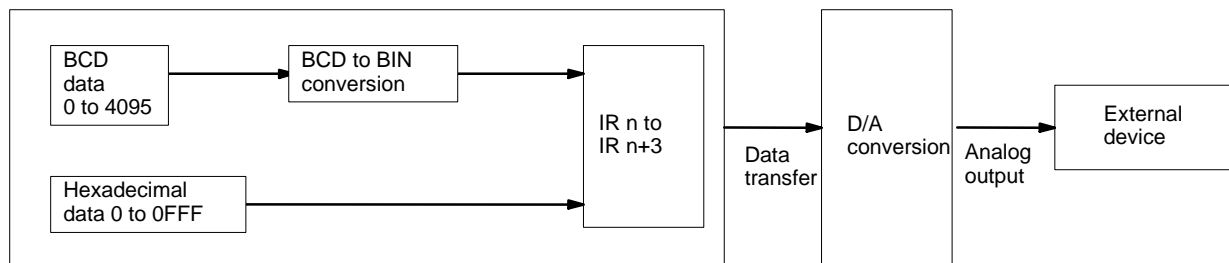

The following diagram illustrates the conversion of values in IR n to IR n+3 to analog output values. The specific analog output ranges to which the binary values are converted depends on the switch settings of the Module.

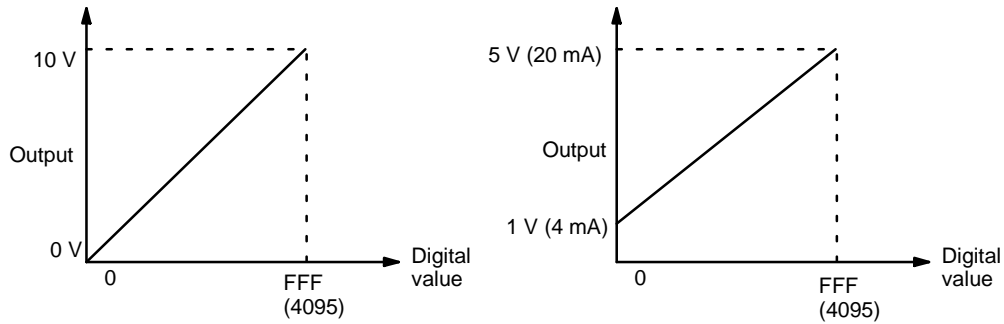

### 4-5-3 Operational Flow

The basic operational flow is illustrated below. Some of these steps have already been described.

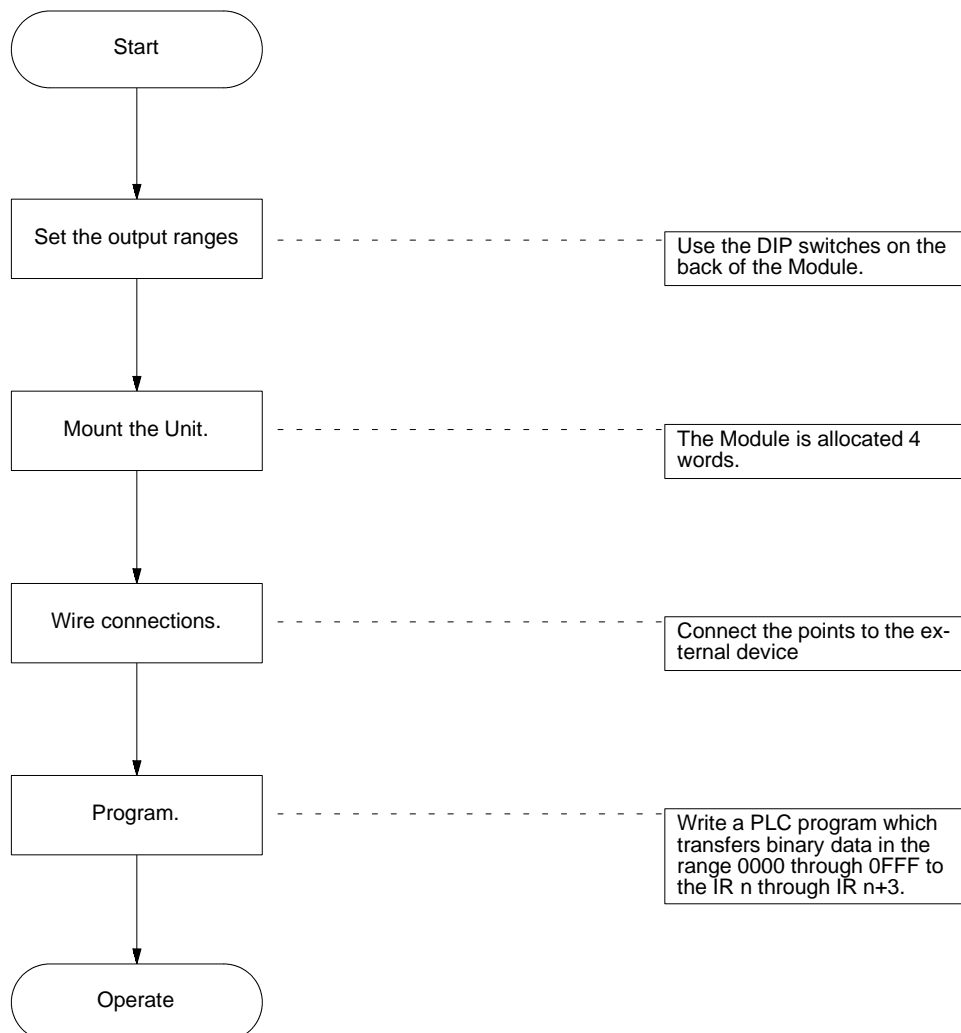

## 4-5-4 IR Bit Allocations

Bit allocations of the words that contain the values that will be converted to analog values for output from each output point on the Analog Output Module are shown below.

Bit	Output words			
	IR n: Point 1	IR n+1: Point 2	IR n+2: Point 3	IR n+3: Point 4
0	D/A conversion data $2^0$	D/A conversion data $2^0$	D/A conversion data $2^0$	D/A conversion data $2^0$
1	D/A conversion data $2^1$	D/A conversion data $2^1$	D/A conversion data $2^1$	D/A conversion data $2^1$
2	D/A conversion data $2^2$	D/A conversion data $2^2$	D/A conversion data $2^2$	D/A conversion data $2^2$
3	D/A conversion data $2^3$	D/A conversion data $2^3$	D/A conversion data $2^3$	D/A conversion data $2^3$
4	D/A conversion data $2^4$	D/A conversion data $2^4$	D/A conversion data $2^4$	D/A conversion data $2^4$
5	D/A conversion data $2^5$	D/A conversion data $2^5$	D/A conversion data $2^5$	D/A conversion data $2^5$
6	D/A conversion data $2^6$	D/A conversion data $2^6$	D/A conversion data $2^6$	D/A conversion data $2^6$
7	D/A conversion data $2^7$	D/A conversion data $2^7$	D/A conversion data $2^7$	D/A conversion data $2^7$
8	D/A conversion data $2^8$	D/A conversion data $2^8$	D/A conversion data $2^8$	D/A conversion data $2^8$
9	D/A conversion data $2^9$	D/A conversion data $2^9$	D/A conversion data $2^9$	D/A conversion data $2^9$
10	D/A conversion data $2^{10}$	D/A conversion data $2^{10}$	D/A conversion data $2^{10}$	D/A conversion data $2^{10}$
11	D/A conversion data $2^{11}$	D/A conversion data $2^{11}$	D/A conversion data $2^{11}$	D/A conversion data $2^{11}$
12 to 15	Usable as work bits.	Usable as work bits.	Usable as work bits.	Usable as work bits.

# SECTION 5

## Programming Considerations

This section provides examples of the most common methods of programming for the Analog I/O Modules. Be sure to read *Section 3 Operation* first to understand the basic operation of the Module before attempting to study these programs.

5-1	AD001 through AD005 Analog Input Modules .....	48
5-2	AD006 and AD007 Analog Input Modules .....	50
5-3	AD101 Analog Input Modules .....	52
5-3-1	Two-word Operation .....	52
5-3-2	Four-word Operation .....	59
5-4	DA001 through DA005 Analog Output Modules .....	69
5-5	DA101 Analog Output Modules .....	71

## 5-1 AD001 through AD005 Analog Input Modules

All that is necessary in programming these Modules is to access the binary-converted analog values at the allocated IR words and use it as required by the control system. The following example program converts two input points to two 4-digit BCD values (4095 maximum) and outputs the result. The words allocated to each Module are shown above the Module. The program is shown on the following page. In programming, ANDW(34) is used to read the data and at the same time filter out the converted value, i.e., only bits 0 through 11.

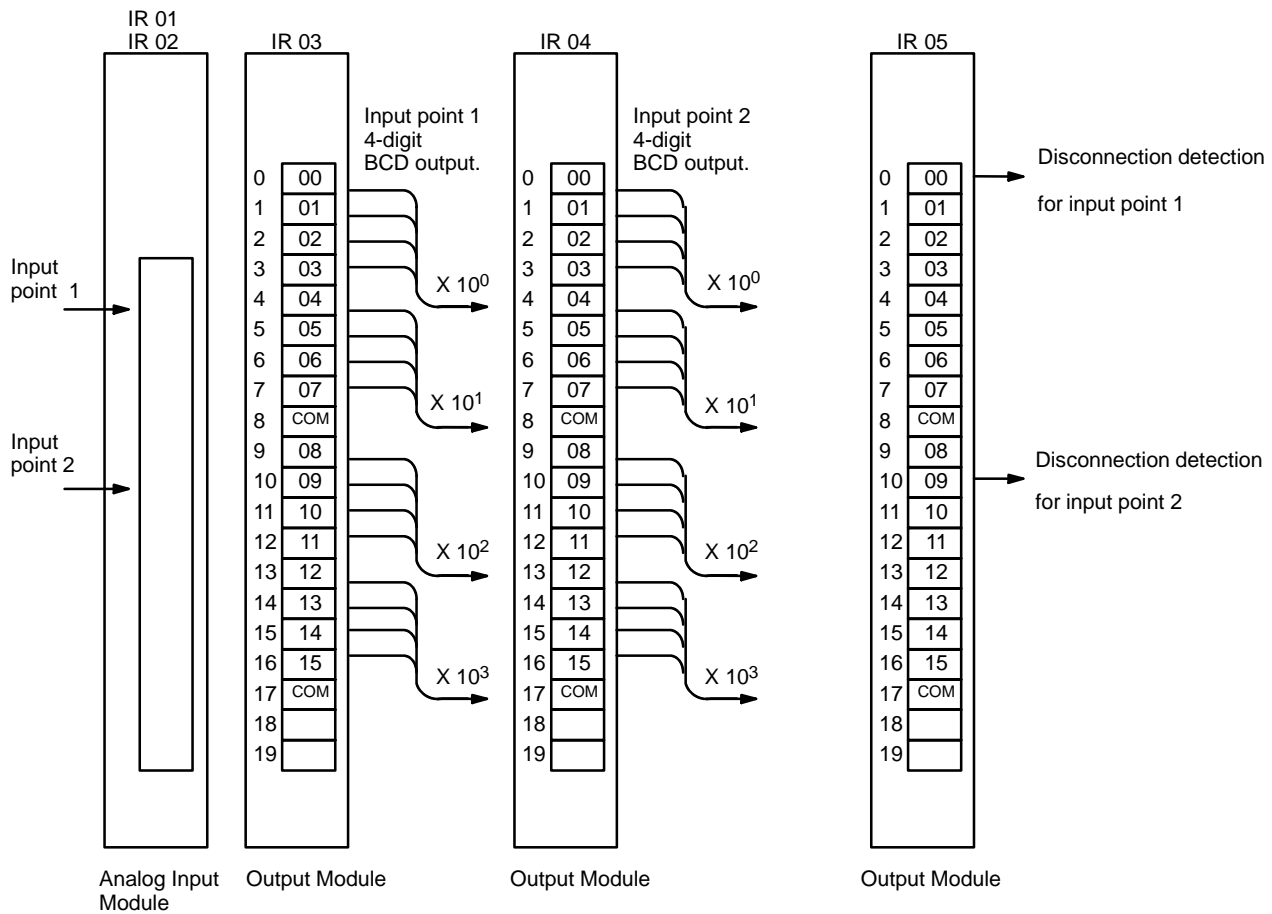



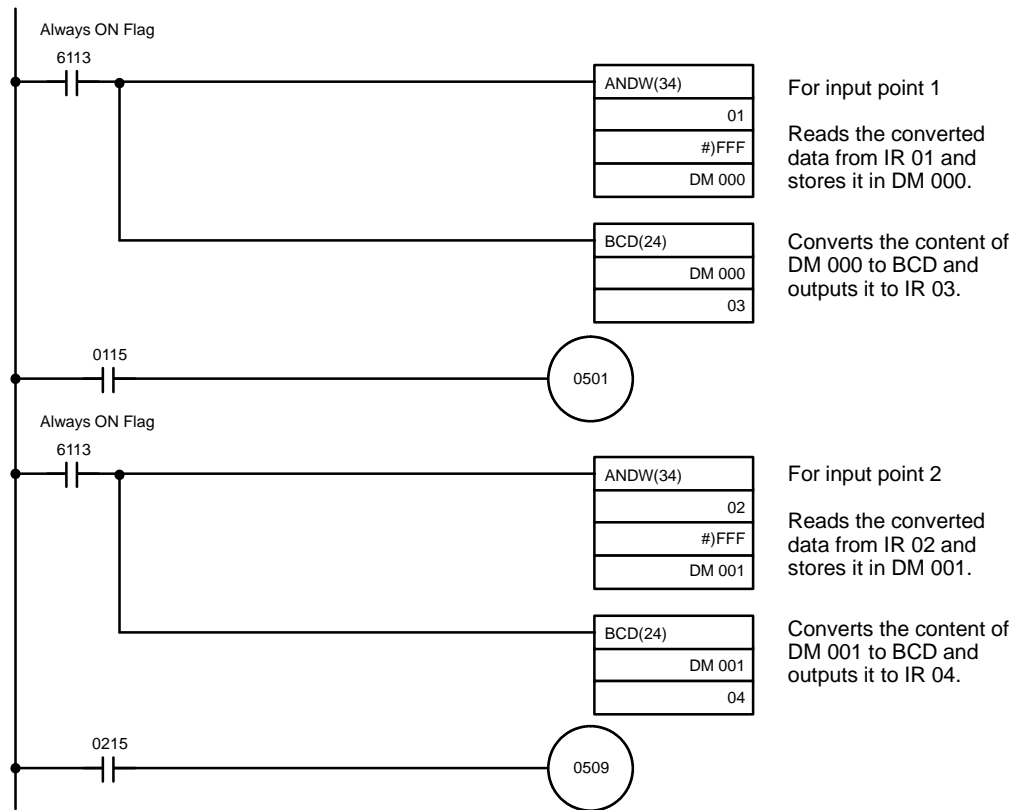

Address	Instruction	Operands
00000	LD	6113
00001	ANDW(34)	
		01
		# 0FFF
		DM 000
00002	BCD(24)	
		DM 000
		03
00003	LD	0115
00004	OUT	0501

Address	Instruction	Operands
00005	LD	6113
00006	ANDW(34)	
		02
		# 0FFF
		DM 001
00007	BCD(24)	
		DM 001
		04
00008	LD	0115
00009	OUT	0501

## 5-2 AD006 and AD007 Analog Input Modules

All that is necessary in programming these Modules is to access the binary-converted analog values at the allocated IR words and use it as required by the control system. The following example program converts four input points to four 4-digit BCD values (1023 maximum) and outputs the result. The words allocated to each Module are shown above the Module. The program is shown on the following page. In programming, ANDW(34) is used to read the data and at the same time filter out the converted value, i.e., only bits 0 through 9.

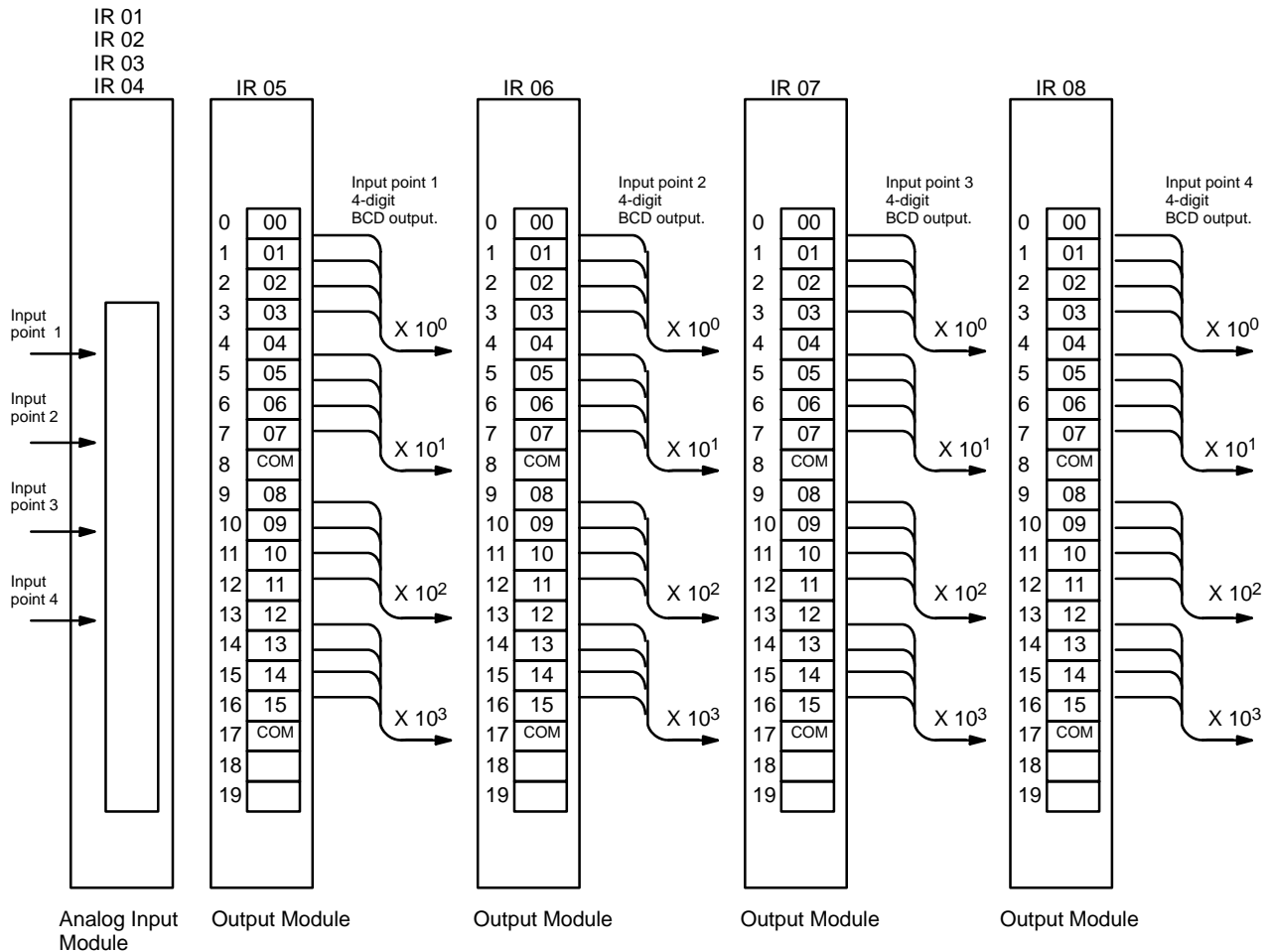

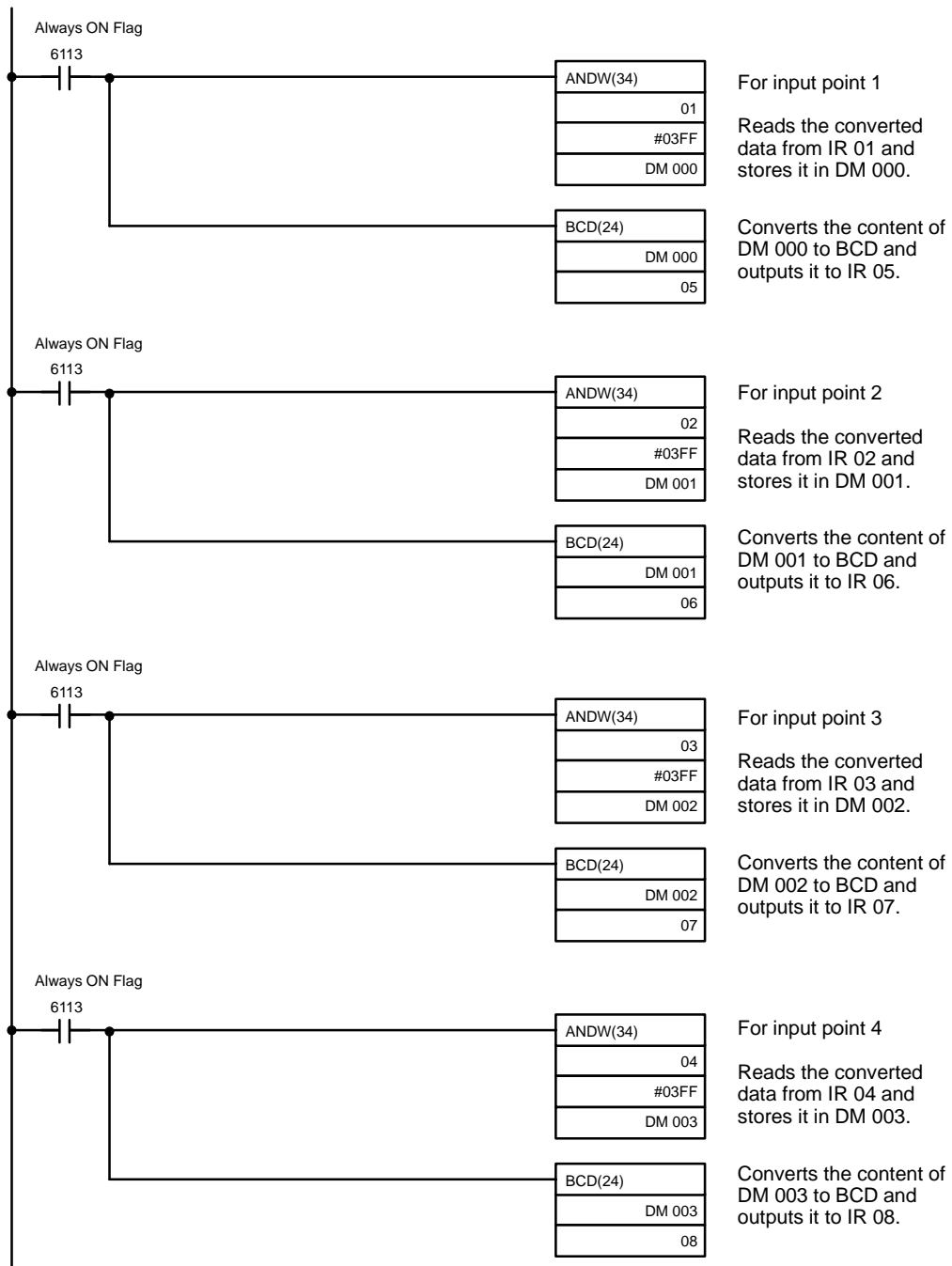

Address	Instruction	Operands
00000	LD	6113
00001	ANDW(34)	
		01
		# 03FF
		DM 000
00002	BCD(24)	
		DM 000
		05
00003	LD	6113
00004	ANDW(34)	
		02
		# 03FF
		DM 001
00005	BCD(24)	
		DM 001
		06

Address	Instruction	Operands
00006	LD	6113
00007	ANDW(34)	
		03
		# 03FF
		DM 002
00008	BCD(24)	
		DM 002
		07
00009	LD	6113
00010	ANDW(34)	
		04
		# 03FF
		DM 003
00011	BCD(24)	
		DM 003
		08

## 5-3 AD101 Analog Input Modules

The operation of the AD101 Analog Input Module depends on the setting of the operation mode switch (see *Section 2 Components and Switch Settings*.) Although two-word operation simplifies programming and always direct reading of analog input values without delays caused by waiting for the I/O refresh period, it is possible only on CPUs that support the I/O WRITE and I/O READ Instructions, WRIT(87) and READ(88).

### 5-3-1 Two-word Operation

READ(88) are used to program transfer of normal and peak binary-converted analog values from the Analog Input Module to the PLC and WRIT(87) is used to program transfer of parameters from the PLC to the Analog Input Module.

When programming, take into account the difference between the time data is written memory and time data is input or output via READ(88) and WRIT(87), i.e., there must be one I/O refresh period between any MOV(21)'s used to set control bits and READ(88) and WRIT(87).

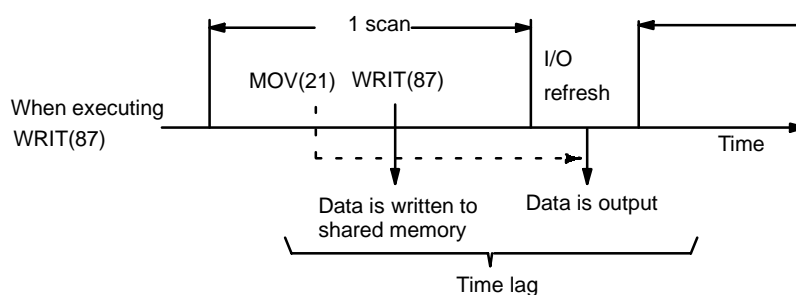

In the following example, we will use the C500 as an example. All 8 points will be used. Means will be calculated for points 5 through 8, and scaling will be performed for points 7 and 8. The Module will be mounted in IR 00, so that IR 00 will be the output word and IR 01 will be the input word. DM 000 through DM 009 will be used for writing data, and DM 100 through DM 108 will be used for reading data. DM 200 through DM 207 will be used to hold the peak values of points 1 through 8.

**Allocation for Reading Data**

The following tables show the memory locations to which the program will move the various values resulting from the analog inputs.

Input point	Normal converted data	Peak value	BCD converted data
1	DM 100	DM 200	DM 300
2	DM 101	DM 201	DM 301
3	DM 102	DM 202	DM 302
4	DM 103	DM 203	DM 303
5	DM 104	DM 204	DM 304
6	DM 105	DM 205	DM 305
7	DM 106	DM 206	DM 306
8	DM 107	DM 207	DM 307

Disconnection Flag	DM 108
--------------------	--------

**Allocation for Writing Data**

The following table shows the memory locations from which the program will write parameters to the Analog Input Module.

Address	Set value	Contents	
DM 000	F 0 F F	Mean value specification/point to be used	
DM 001	C 0 0 0	Scaling specification	
DM 002	0 0 0 5	Point 5	Mean value data (Sampling counts)
DM 003	0 0 1 0	Point 6	
DM 004	0 0 2 0	Point 7	
DM 005	0 0 5 0	Point 8	
DM 006	0 0 0 0	Point 7 Offset data	Scaling data
DM 007	3 0 0 0	Point 7 Gain data	
DM 008	1 0 0 0	Point 8 Offset data	
DM 009	5 0 0 0	Point 8 Gain data	

Contents of DM 000

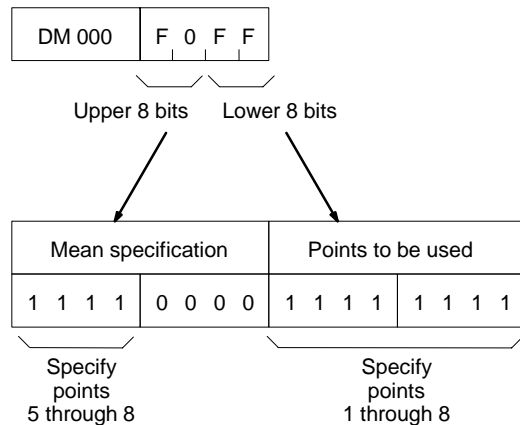

Contents of DM 001

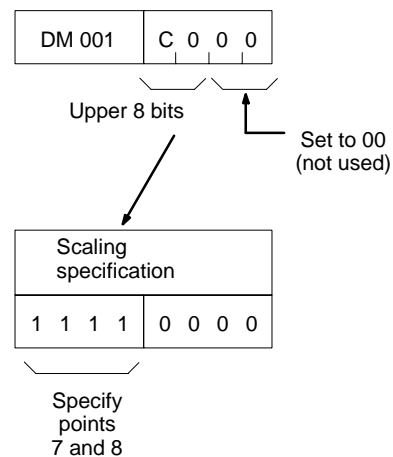

**Note:** The data writing area extends to 27 words maximum. If some points are not used for mean value or scaling, as shown above, the area will be smaller. Set only the data which needs to be set according to the settings of the first two words (here DM 000 and DM 001).

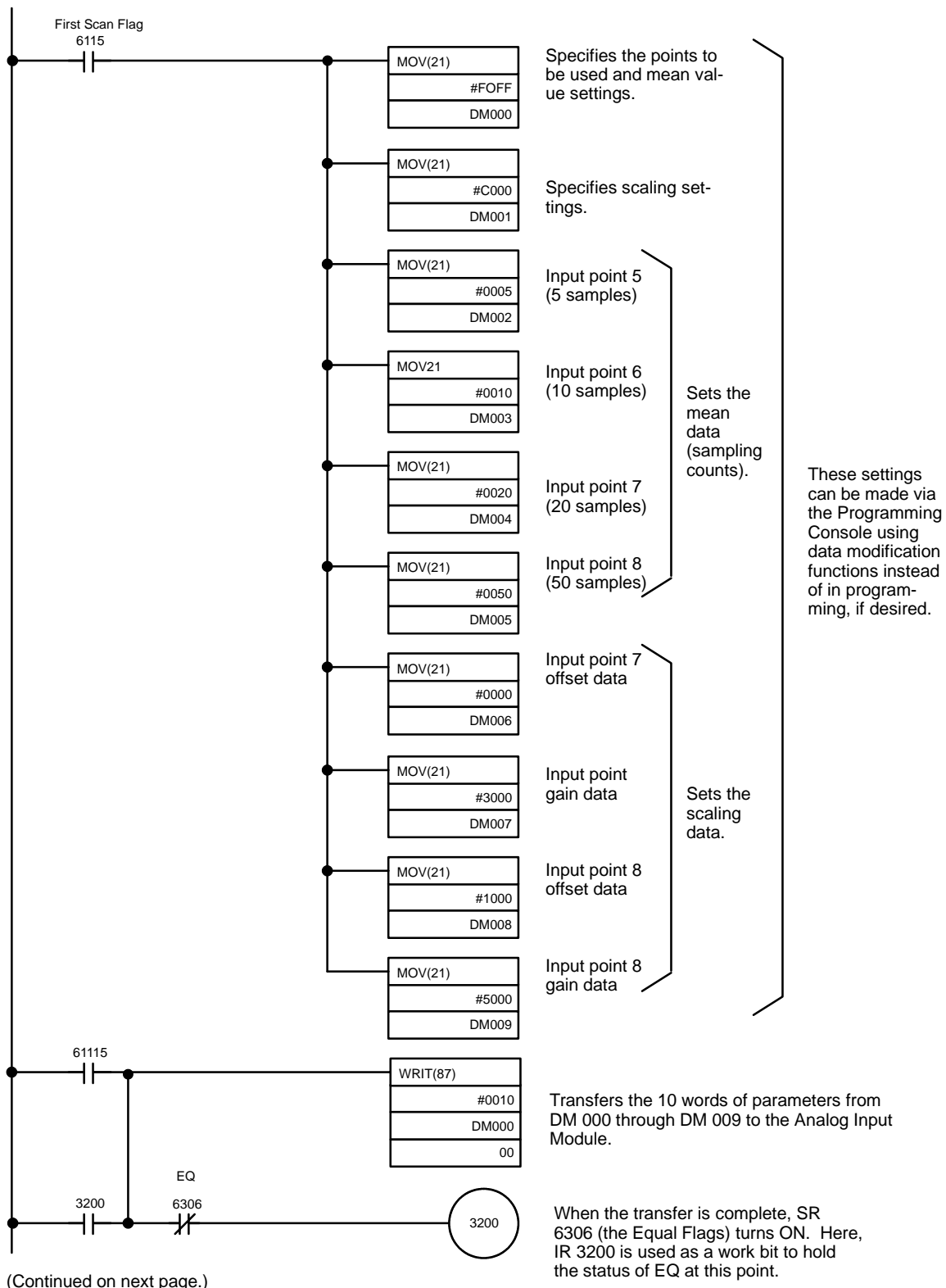

(From previous page.)

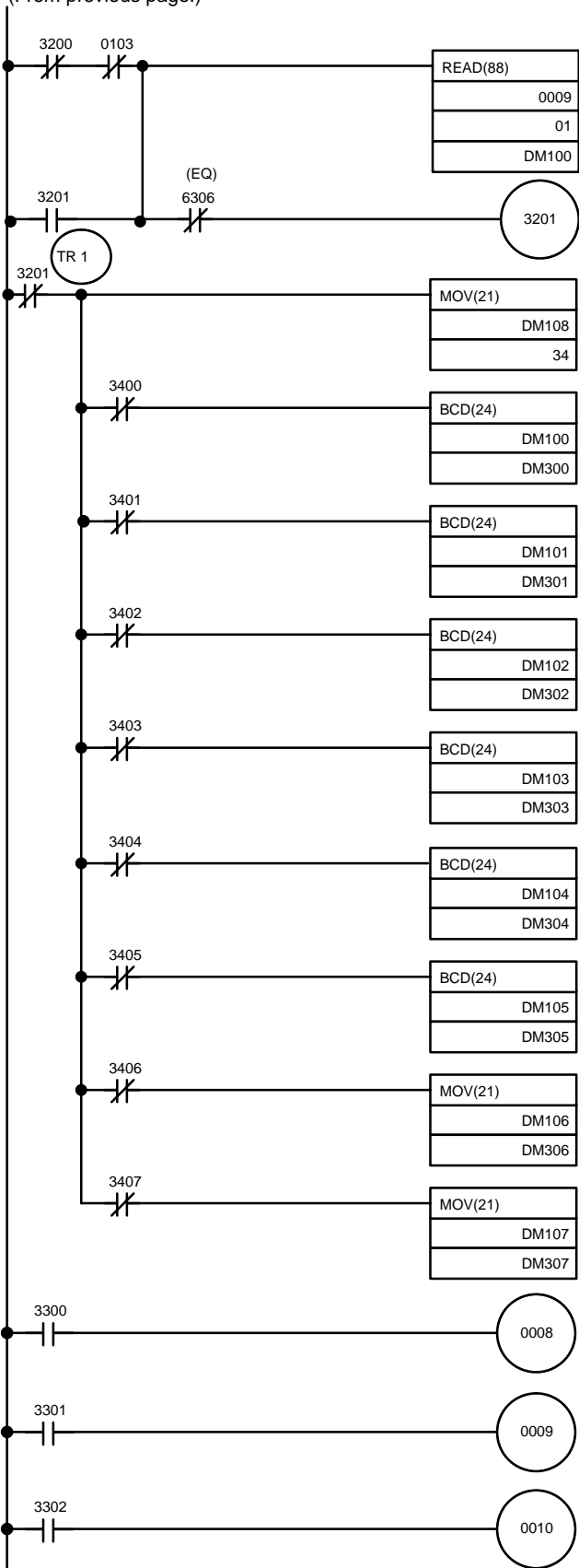

A/D converted data and the Disconnection Flags from points 1 through 8 are read in and stored in DM 100 through DM 108. IR 0103 (the Unconfirmed Data Flag) stops unconfirmed data from being accepted.

When reading is complete, SR 6306 (the Equal Flags) turns ON, activating IR 3201.

Disconnection Flags (the lower 8 bits of DM 108) are output to IR 34.

Input point 1

Input point 2

Input point 3

Input point 4

Input point 5

Input point 6

Input point 7

Input point 8

Binary data from points 1 through 6 is converted to BCD and written to DM 300 through DM 305. IR 3400 through 3407 are used as work bits activated by the Disconnection Flags to prevent data from being moved when an input is disconnected.

Scaling (BCD output) is performed on points 7 and 8 and the data is written to DM 306 and DM 307 without conversion.

(Continued on next page.)

(From previous page.)

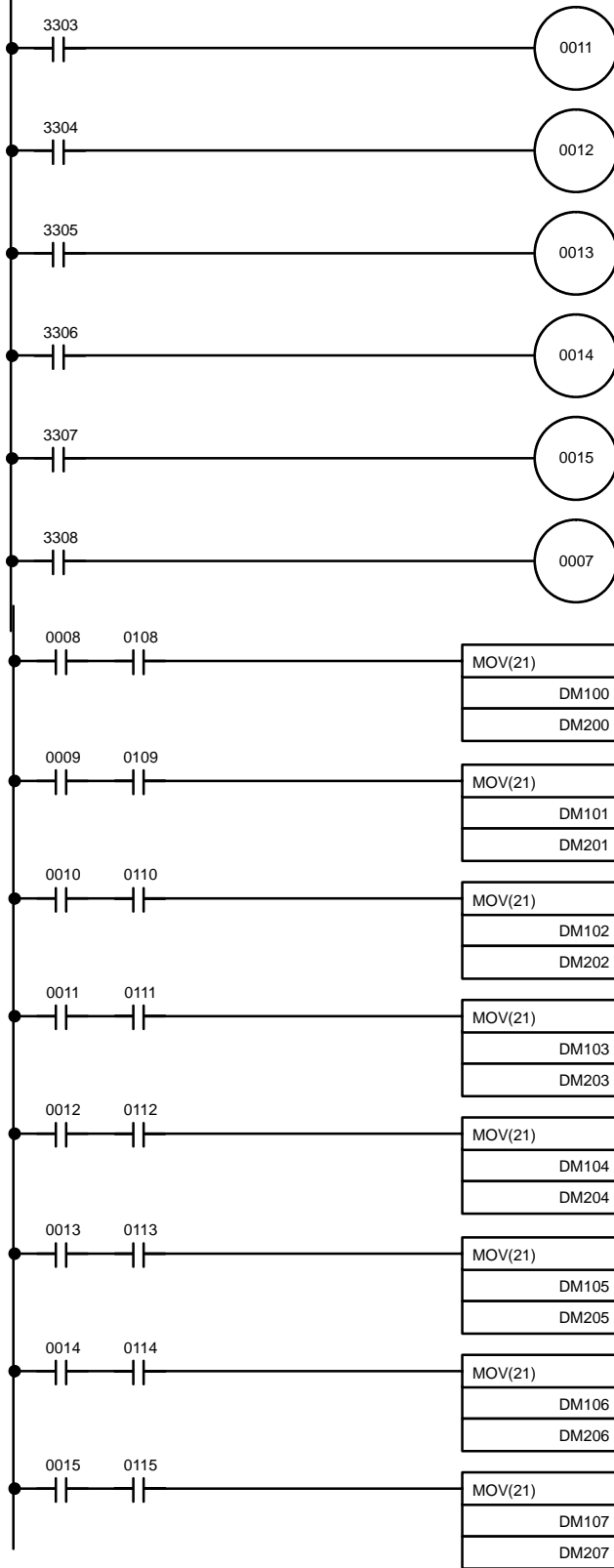

IR 33 is used for peak values. IR 0008 through IR 0015 are used to activate moving the peak values into the desired storage locations. Turn ON the Peak Read Bits and check the Peak Flags to read the peak values (see the next page). IR 0007 is used as the Peak Reset Flag. Turn both the Peak Reset Flag and the Peak Read Bit ON to reset a peak value.

IR 0108 through IR 0115 are used as Peak Flags. When the input point data reaches a peak value, the flag corresponding to the input point will turn ON. When both the Peak Read Bit and Peak Flags are ON, the peak value, which will have been read at the last READ(87), will be written to DM 200 through DM 207.



Address	Instruction	Operands
00000	LD	6115
00001	MOV(21)	
		# #F0FF
		DM 000
00002	MOV(21)	
		# #C000
		DM 001
00003	MOV(21)	
		# #0005
		DM 002
00004	MOV(21)	
		# #0010
		DM 003
00005	MOV(21)	
		# #0020
		DM 004
00006	MOV(21 )	
		# #0050
		DM 005
00007	MOV(21)	
		# #0000
		DM 006
00008	MOV(21)	
		# #3000
		DM 007
00009	MOV(21)	
		# #1000
		DM 008
00010	MOV(21)	
		# #5000
		DM 009
00011	LD	6115
00012	WRIT(87)	
		# 0010
		DM 000
		00
00013	LD	3200
00014	AND NOT	6306
00015	OUT	3200
00016	LD NOT	3200
00017	AND NOT	0103
00018	OR	3201
00019	READ(88)	
		0009
		01
		DM 100
00020	LD NOT	6306
00021	AND LD	
00022	OUT	3201
00023	LD NOT	3201
00024	OUT	TR 1
00025	MOV(21)	
		DM 108
		34
00026	AND NOT	3400

Address	Instruction	Operands
00027	BCD(24)	
		DM 100
		DM 300
00028	LD	TR 1
00029	AND NOT	3401
00030	BCD(24)	
		DM 101
		DM 301
00031	LD	TR 1
00032	AND NOT	3402
00033	BCD(24)	
		DM 102
		DM 302
00034	LD	TR 1
00035	AND NOT	3403
00036	BCD(24)	
		DM 103
		DM 303
00037	LD	TR 1
00038	AND NOT	3404
00039	BCD(24)	
		DM 104
		DM 304
00040	LD	TR 1
00041	AND NOT	3405
00042	BCD(24)	
		DM 105
		DM 305
00043	LD	TR 1
00044	AND NOT	3406
00045	MOV(21)	
		DM 106
		DM 306
00046	LD	TR 1
00047	AND NOT	3407
00048	MOV(21)	
		DM 107
		DM 307
00059	LD	3300
00060	OUT	0008
00062	LD	3301
00063	OUT	0009
00064	LD	3302
00065	OUT	0010
00066	LD	3303
00067	OUT	0011
00068	LD	3304
00069	OUT	0012
00070	LD	3305
00071	OUT	0013
00072	LD	3306
00073	OUT	0014
00074	LD	3307
00075	OUT	0015
00076	LD	3308
00077	OUT	0007

(Continued on next page.)

Address	Instruction	Operands
00077	LD	0008
00078	AND	0108
00079	MOV(21)	
		DM 100
		DM 200
00080	LD	0009
00081	AND	0109
00082	MOV(21)	
		DM 100
		DM 200
00083	LD	0010
00084	AND	0110
00085	MOV(21)	
		DM 100
		DM 200
00086	LD	0011
00087	AND	0111
00088	MOV(21)	
		DM 100
		DM 200

Address	Instruction	Operands
00089	LD	0012
00090	AND	0112
00091	MOV(21)	
		DM 100
		DM 200
00092	LD	0013
00093	AND	0113
00094	MOV(21)	
		DM 100
		DM 200
00095	LD	0014
00096	AND	0114
00097	MOV(21)	
		DM 100
		DM 200
00098	LD	0015
00099	AND	0115
00100	MOV(21)	
		DM 100
		DM 200

## 5-3-2 Four-word Operation

The following example is for four-word operation. We will be using the C500 in this example.

### IR Allocations

The following table shows the allocations of the IR words allocated to the Analog Input Module.

During four-word operation, data is transferred between the Module and PLC according to the settings of these control bits and flags.

Bit	Output		Input	
	IR 00	IR 01	IR 02	IR 03
00	Writing data	Point 1 Control Bit	Reading data	Point 1 Read Flag
01		Point 2 Control Bit		Point 2 Read Flag
02		Point 3 Control Bit		Point 3 Read Flag
03		Point 4 Control Bit		Point 4 Read Flag
04		Point 5 Control Bit		Point 5 Read Flag
05		Point 6 Control Bit		Point 6 Read Flag
06		Point 7 Control Bit		Point 7 Read Flag
07		Point 8 Control Bit		Point 8 Read Flag
08		Normal/Peak Control Bit		Disconnection Flag
09				Normal/Peak Flag
10		Not used.		
11			Not used.	
12		Peak Reset Bit	Not used.	
13		A/D Conversion Bit		
14		PC Write Completed Bit		A/D Read Completed Flag
15	PC Read Completed Bit		A/D Write Completed Flag	

### DM Area Allocation

The following table shows the bits used to store the various data resulting from the binary-converted analog input values.

Input point	Mean value (sampling count)		Converted data (normal)	Converted data (peak value)
1	DM 000	0 0 0 0	DM 100	DM 200
2	DM 001	0 0 0 0	DM 101	DM 201
3	DM 002	0 0 0 0	DM 102	DM 202
4	DM 003	0 0 0 0	DM 103	DM 203
5	DM 004	0 0 0 5	DM 104	DM 204
6	DM 005	0 0 1 0	DM 105	DM 205
7	DM 006	0 0 2 0	DM 106	DM 206
8	DM 007	0 0 5 0	DM 107	DM 207

**Program Using Only Point 1** The following program is used when only one of the input points is used.

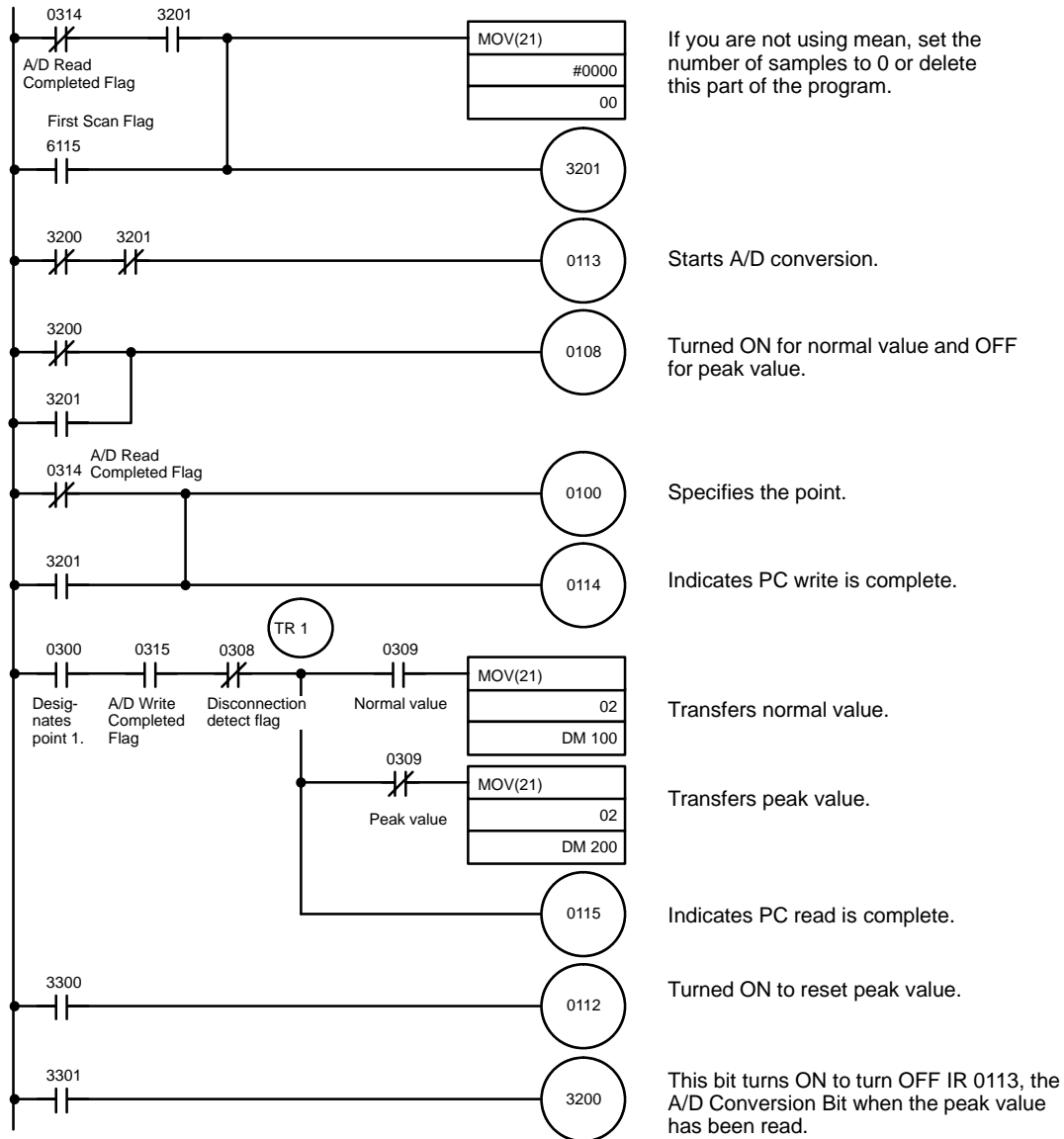

Address	Instruction	Operands
00000	LD NOT	0314
00001	AND	3201
00002	OR	6115
00003	MOV(21)	
		# 0000
		00
00004	OUT	3201
00005	LD NOT	3200
00006	AND NOT	3201
00007	OUT	0113
00008	LD NOT	3200
00009	OR	3201
00010	OUT	0108
00011	LD NOT	0314
00012	OR	3201
00013	OUT	0100
00014	OUT	0114
00015	LD	0300

Address	Instruction	Operands
00016	AND	0315
00017	AND NOT	0308
00018	OUT	TR 1
00019	AND	0309
00020	MOV(21)	
		02
		DM 100
00021	LD	TR 1
00022	AND NOT	0309
00023	MOV(21)	
		02
		DM 200
00024	OUT	0115
00025	LD	3300
00026	OUT	0112
00027	LD	3301
00028	OUT	3200

**Program Using All 8 Points** The following program can be used when all eight input points are being used.

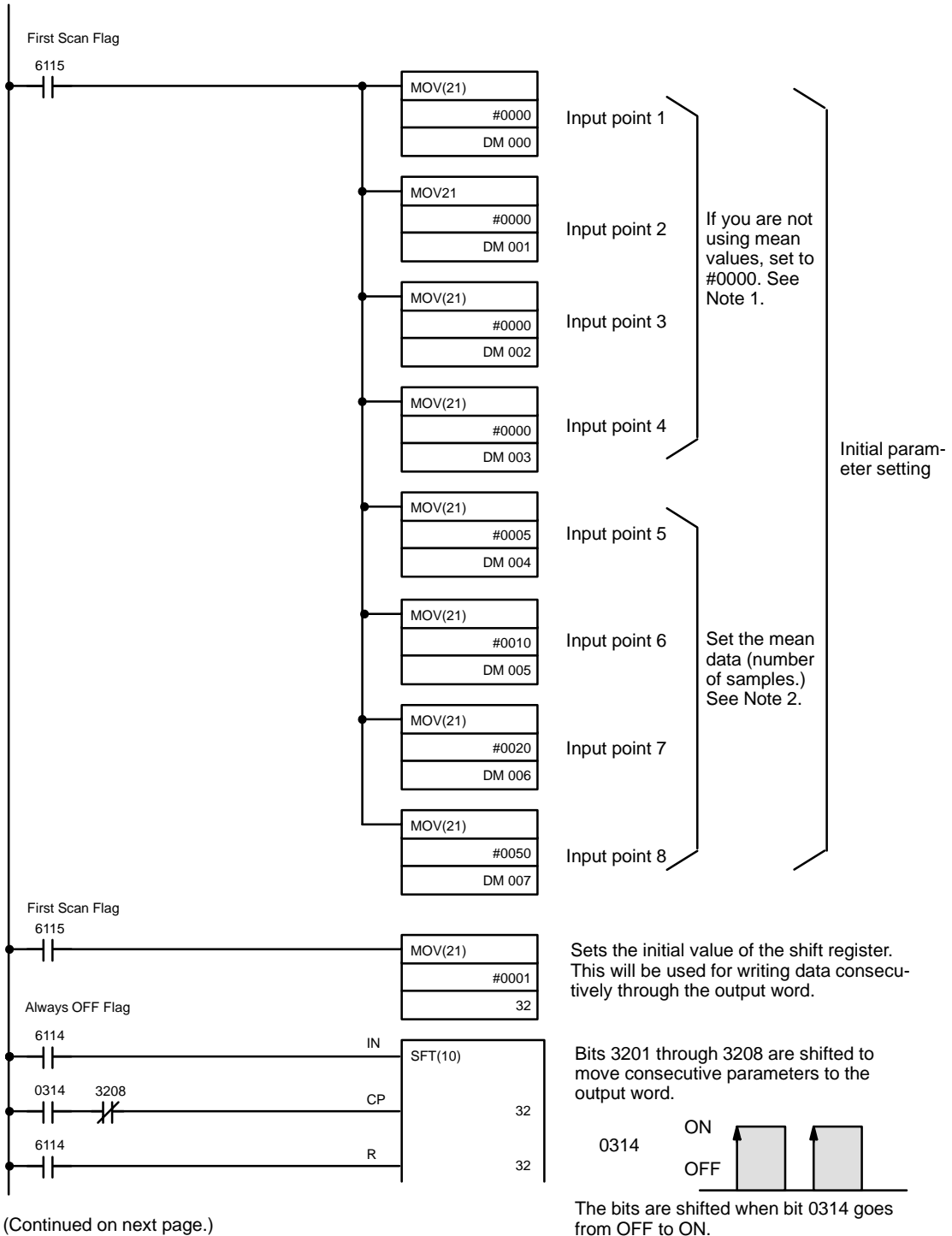

(Continued on next page.)

- Note**
1. When mean is not used, no setting is necessary. The above example includes settings for all points to allow for easy modification.
  2. Mean processing starts after the points are specified, It takes 10 ms x (number of samples) for the data to be output.

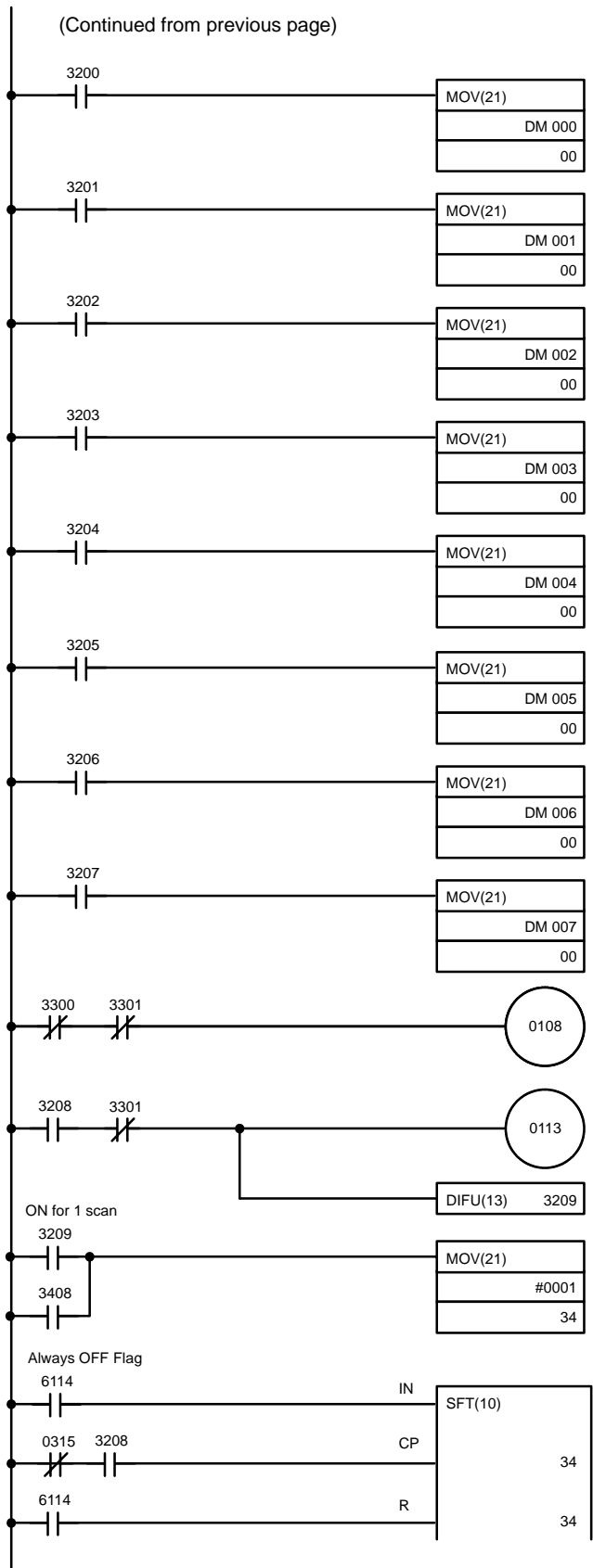

Bit 3209 turns OFF after 8 parameters are written sequentially output to the Module..

Turns ON for normal values and OFF for peak values.

A/D conversion starts. Bit 3208 turns ON after data writing is complete.

Sets the initial value of the shift register. This will be used for reading data.

The specified bits are shifted sequentially. Bit 0315 is the A/D Write Completed Flag.

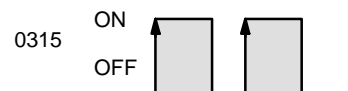

The bits are shifted when bit 0315 goes from OFF to ON.

(Continued on next page.)

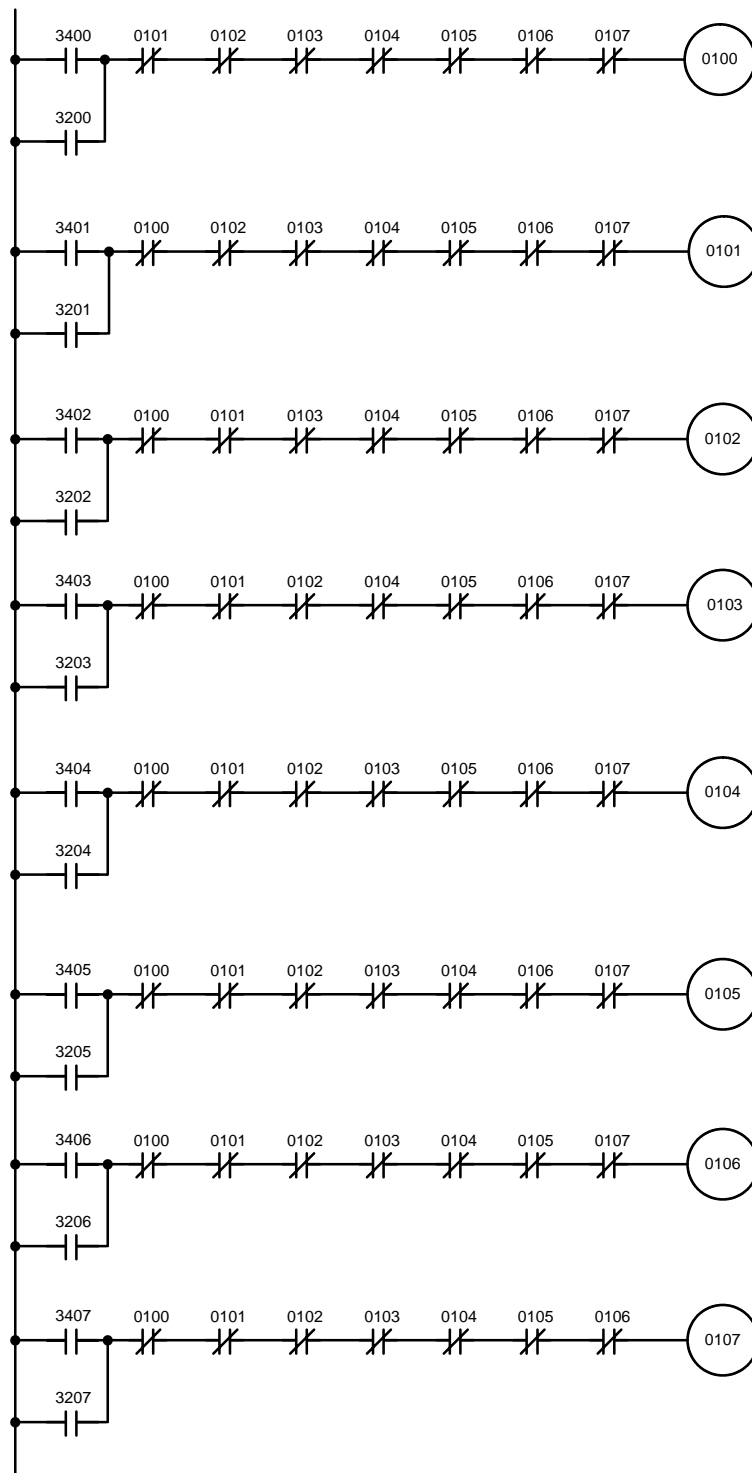

Specify the points to be read. These are set up so that only one of the operand of these OUT's is ON at the same time.

(Continued on next page)

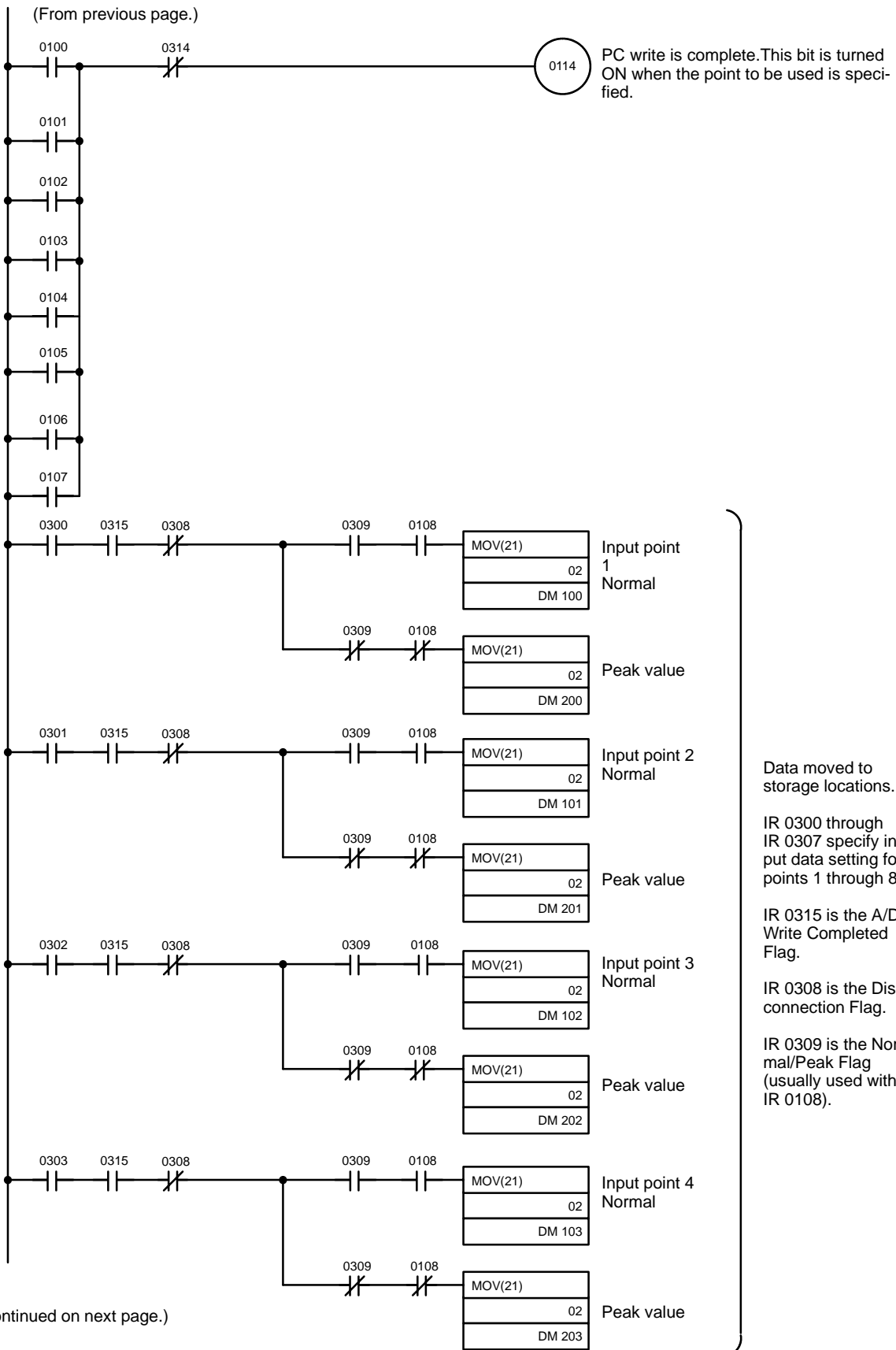



(From previous page.)

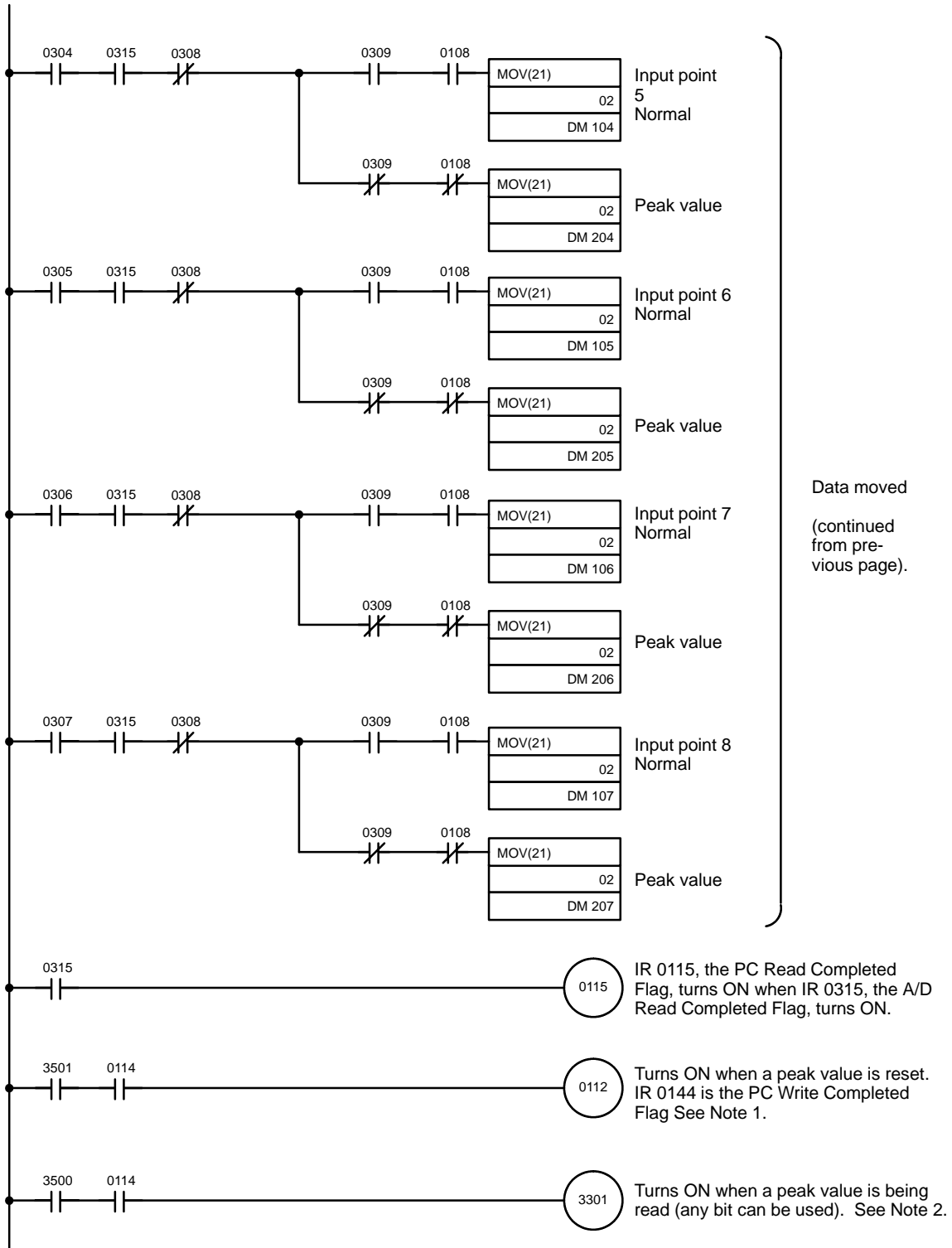

- Note**
1. The peak value is reset when the Peak Reset Flag turns OFF.
  2. The peak value is held while the Peak Flag is ON. IR 0114 initiates the reading of new peak values while IR 3501 is ON.

Address	Instruction	Operands
00000	LD	6115
00001	MOV(21)	
		# 0000
		DM 000
00002	MOV(21)	
		# 0000
		DM 001
00003	MOV(21)	
		# 0000
		DM 002
00004	MOV(21)	
		# 0000
		DM 0003
00005	MOV(21)	
		# 0005
		DM 004
00006	MOV(21)	
		# 0010
		DM 005
00007	MOV(21)	
		# 0020
		DM 006
00008	MOV(21)	
		# 0050
		DM 007
00009	LD	6115
00010	MOV(21)	
		# 0001
		32
00011	LD	6114
00012	LD	0314
00013	AND NOT	3208
00014	LD	6114
00015	SFT(10)	
		32
		32
00016	LD	3200
00017	MOV(21)	
		DM 000
		00
00018	LD	3201
00019	MOV(21)	
		DM 001
		00
00020	LD	3202
00021	MOV(21)	
		DM 002
		00
00022	LD	3203
00023	MOV(21)	
		DM 003
		00
00024	LD	3204
00025	MOV(21)	
		DM 004
		00

Address	Instruction	Operands
00026	LD	3205
00027	MOV(21)	
		DM 005
		00
00028	LD	3206
00029	MOV(21)	
		DM 006
		00
00030	LD	3207
00031	MOV(21)	
		DM 007
		00
00032	LD NOT	3300
00033	AND NOT	3301
00034	OUT	0108
00035	LD	3208
00036	AND NOT	3301
00037	OUT	0113
00038	DIFU(13)	3209
00039	LD	3209
00040	OR	3408
00041	MOV(21)	
		# 0001
		34
00042	LD	6114
00043	LD NOT	0315
00044	AND	3208
00045	LD	6114
00046	SFT(10)	
		34
		34
00047	LD	3400
00048	OR	3200
00049	AND NOT	0101
00050	AND NOT	0102
00051	AND NOT	0103
00052	AND NOT	0104
00053	AND NOT	0105
00054	AND NOT	0106
00055	AND NOT	0107
00056	OUT	0100
00057	LD	3401
00058	OR	3201
00059	AND NOT	0100
00060	AND NOT	0102
00061	AND NOT	0103
00062	AND NOT	0104
00063	AND NOT	0105
00064	AND NOT	0106
00065	AND NOT	0107
00066	OUT	0101
00067	LD	3402
00068	OR	3202
00069	AND NOT	0100
00070	AND NOT	0101
00071	AND NOT	0103

(Continued on next page.)

Address	Instruction	Operands
00072	AND NOT	0104
00073	AND NOT	0105
00074	AND NOT	0106
00075	AND NOT	0107
00076	OUT	0102
00077	LD	3403
00078	OR	3203
00079	AND NOT	0100
00080	AND NOT	0101
00081	AND NOT	0102
00082	AND NOT	0104
00083	AND NOT	0105
00084	AND NOT	0106
00085	AND NOT	0107
00086	OUT	0103
00087	LD	3404
00088	OR	3204
00089	AND NOT	0100
00090	AND NOT	0101
00091	AND NOT	0102
00092	AND NOT	0103
00093	AND NOT	0105
00094	AND NOT	0106
00095	AND NOT	0107
00096	OUT	0104
00097	LD	3405
00098	OR	3205
00099	AND NOT	0100
00100	AND NOT	0101
00101	AND NOT	0102
00102	AND NOT	0103
00103	AND NOT	0104
00104	AND NOT	0106
00105	AND NOT	0107
00106	OUT	0105
00107	LD	3406
00108	OR	3206
00109	AND NOT	0100
00110	AND NOT	0101
00111	AND NOT	0102
00112	AND NOT	0103
00113	AND NOT	0104
00114	AND NOT	0105
00115	AND NOT	0107
00116	OUT	0106
00117	LD	3407
00118	OR	3207
00119	AND NOT	0100
00120	AND NOT	0101
00121	AND NOT	0102
00122	AND NOT	0103
00123	AND NOT	0104
00124	AND NOT	0105
00125	AND NOT	0106
00126	LD	0100
00127	OR	0101

Address	Instruction	Operands
00128	OR	0102
00129	OR	0103
00130	OR	0104
00131	OR	0105
00132	OR	0106
00133	OR	0107
00134	AND NOT	0314
00135	OUT	0114
00136	LD	0300
00137	AND	0315
00138	AND NOT	0308
00139	OUT	TR 1
00140	AND	0309
00141	AND	0108
00142	MOV(21)	
		02
		DM 100
00143	LD	TR 1
00144	AND NOT	0309
00145	AND NOT	0108
00146	MOV(21)	
		02
		DM 200
00148	LD	0301
00149	AND	0315
00150	AND NOT	0308
00151	OUT	TR 1
00152	AND	0309
00153	AND	0108
00154	MOV(21)	
		02
		DM 101
00155	LD	TR 1
00156	AND NOT	0309
00157	AND NOT	0108
00158	MOV(21)	
		02
		DM 201
00159	LD	0302
00160	AND	0315
00161	AND NOT	0308
00162	OUT	TR 1
00163	AND	0309
00164	AND	0108
00165	MOV(21)	
		02
		DM 102
00166	LD	TR 1
00167	AND NOT	0309
00168	AND NOT	0108
00169	MOV(21)	
		02
		DM 202
00170	LD	0303
00171	AND	0315

(Continued on next page.)

Address	Instruction	Operands
00172	AND NOT	0308
00173	OUT	TR 1
00174	AND	0309
00175	AND	0108
00176	MOV(21)	
		02
		DM 103
00177	LD	TR 1
00178	AND NOT	0309
00179	AND NOT	0108
00180	MOV(21)	
		02
		DM 203
00181	LD	0304
00182	AND	0315
00183	AND NOT	0308
00184	OUT	TR 1
00185	AND	0309
00186	AND	0108
00187	MOV(21)	
		02
		DM 104
00188	LD	TR 1
00189	AND NOT	0309
00190	AND NOT	0108
00191	MOV(21)	
		02
		DM 204
00192	LD	0305
00193	AND	0315
00194	AND NOT	0308
00195	OUT	TR 1
00196	AND	0309
00197	AND	0108
00198	MOV(21)	
		02
		DM 105
00199	LD	TR 1
00200	AND NOT	0309
00201	AND NOT	0108
00202	MOV(21)	

Address	Instruction	Operands
		02
		DM 205
00203	LD	0306
00204	AND	0315
00205	AND NOT	0308
00206	OUT	TR 1
00207	AND	0309
00208	AND	0108
00209	MOV(21)	
		02
		DM 106
00210	LD	TR 1
00211	AND NOT	0309
00212	AND NOT	0108
00213	MOV(21)	
		02
		DM 206
00214	LD	0307
00215	AND	0315
00216	AND NOT	0308
00217	OUT	TR 1
00218	AND	0309
00219	AND	0108
00220	MOV(21)	
		02
		DM 107
00221	LD	TR 1
00222	AND NOT	0309
00223	AND NOT	0108
00224	MOV(21)	
		02
		DM 207
00225	LD	0315
00226	OUT	0115
00227	LD	3501
00228	AND	0114
00229	OUT	0112
00230	LD	3500
00231	AND	0114
00232	OUT	3301

### 5-4 DA001 through DA005 Analog Output Modules

All that is necessary in programming these Modules is to move a binary value (up to 4095) to the word allocated to the desired output point. The following example converts BCD input from outside the PLC to binary and places the results in the proper output words for unipolar outputs. The words allocated to each Module are shown above the Module. The program, written for a C500, is shown on the following page.

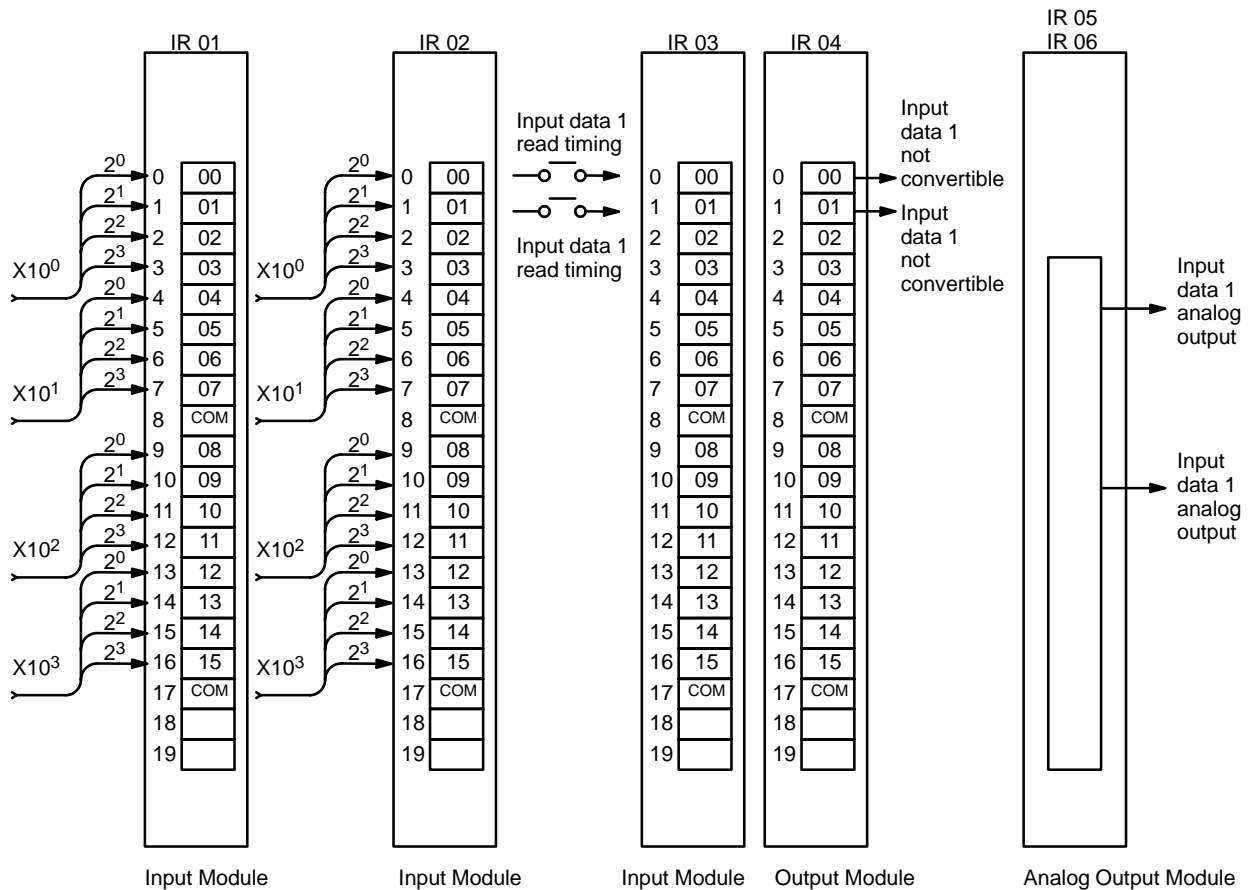

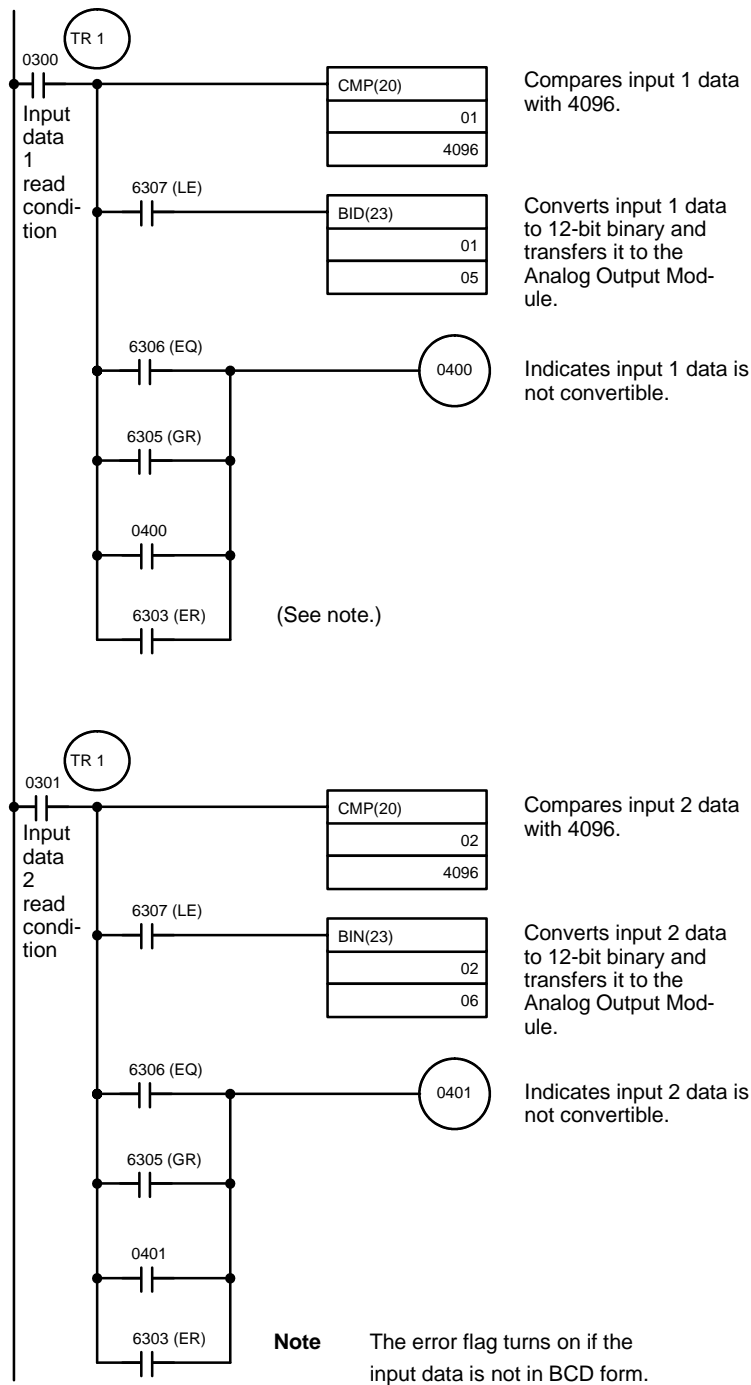

Address	Instruction	Operands
00000	LD	0300
00001	OUT	TR 1
00002	CMP(20)	
		01
		4096
00003	AND	6307
00004	BIN(23)	
		01
		05
00005	LD	TR 1
00006	AND	6306
00007	OR	6305
00008	OR	0400
00009	OR	6303
00010	OUT	0400
00011	LD	0301
00012	OUT	TR 1
00013	CMP(20)	
		02
		4096
00014	AND	6307
00015	BIN(23)	
		02
		06
00016	LD	TR 1
00017	AND	6306
00018	OR	6305
00019	OR	0401
00020	OR	6303
00021	OUT	0401

## 5-5 DA101 Analog Output Modules

All that is necessary in programming this Modules is to move a binary value (up to 4095) to the word allocated to the desired output point.

The following program, written for the C500, transfer data between the PLC and Analog Output Module. The conversion data is stored in DM 100. The Module will uses IR 10 through IR 13. Only the programming for point 1 (IR 10) is shown. The programming for the rest of the points follows the same logic.

### Program for BCD Data

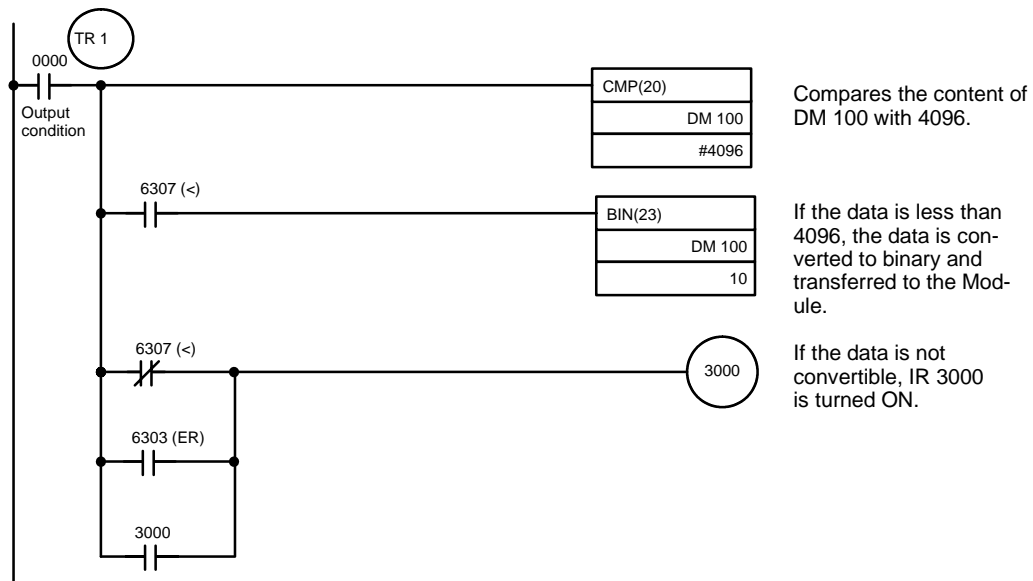

Address	Instruction	Operands
00000	LD	0000
00001	OUT	TR 1
00002	CMP(20)	
		DM 100
		# 4096
00003	AND	6307

Address	Instruction	Operands
00004	BIN(23)	
		DM 100
		10
00005	LD	TR 1
00006	AND NOT	6307
00007	OR	6303
00008	OR	3000
00009	OUT	3000

Program for Binary Data

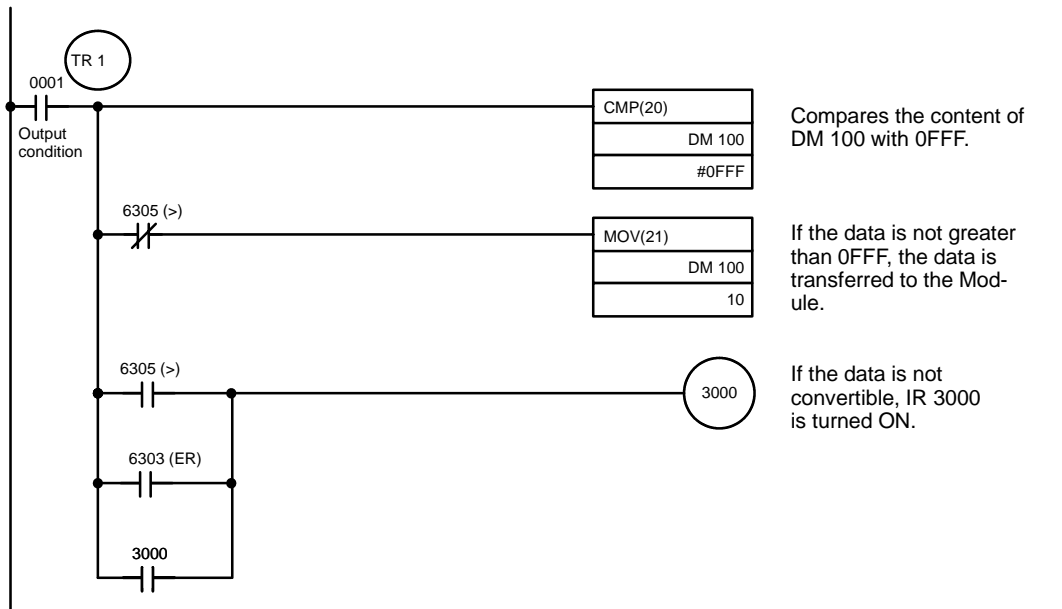

Address	Instruction	Operands
00000	LD	0001
00001	OUT	TR 1
00002	CMP(20)	DM 100 # 0FFF
00003	AND NOT	6305

Address	Instruction	Operands
00004	MOV(21)	DM 100 10
00005	LD	TR 1
00006	AND	6305
00007	OR	6303
00008	OR	3000
00009	OUT	3000



# Appendix A

## Standard Models

### Analog Input Modules

PLC	Specifications	Model
C120	1 to 5 V, 4 to 20 mA	3G2A6-AD006
	0 to 10 V	3G2A6-AD007
C500	0 to 10 V, 0 to 20 mA (adjustable)	C500-AD101
C1000H	1 to 5 V, 4 to 20 mA	3G2A5-AD001
C2000H	0 to 10 V	3G2A5-AD002
	0 to 5 V	3G2A5-AD003
	-10 to 10 V	3G2A5-AD004
	-5 to 5 V	3G2A5-AD005
	1 to 5 V, 4 to 20 mA	3G2A5-AD006
	0 to 10 V	3G2A5-AD007

### Analog Output Modules

PLC	Specifications	Model
C120	1 to 5 V, 4 to 20 mA	3G2A6-DA001
	0 to 10 V	3G2A6-DA002
	0 to 5 V	3G2A6-DA003
	-10 to 10 V	3G2A6-DA004
	-5 to 5 V	3G2A6-DA005
C500	0 to 10 V, 1 to 5 V, 4 to 20 mA	C500-DA101
C1000H	1 to 5 V, 4 to 20 mA	3G2A5-DA001
C2000H	0 to 10 V	3G2A5-DA002
	0 to 5 V	3G2A5-DA003
	-10 to 10 V	3G2A5-DA004
	-5 to 5 V	3G2A5-DA005

### Expansion I/O Racks

(For connecting Analog I/O Modules to the C120)

Power supply	Model
100 VAC	3G2C4-SI025
200 VAC	3G2C4-SI026



# Appendix B Specifications

## AD001 through AD005 Analog Input Modules

All general specifications of the AD001 through AD005 conform to those of the C Series except the following:

- Insulation resistance between the external terminals and the frame: 5 MΩ min. (at 250 VDC)
- Dielectric strength between the external terminals and the frame: 500 VAC, 50/60 Hz for 1 minute

<b>Number of analog inputs</b>	2	
<b>Input signal range</b> (See Note 1.)	Voltage inputs	1 to 5 V (AD001)
		0 to 10 V (AD002)
		0 to 5 V (AD003)
		-10 to 10 V (AD004)
		-5 to 5 V (AD005)
	Current inputs	4 to 20 mA (AD001)
<b>Input impedance</b>	Voltage input: 1 MΩ min.	
	Current input: 250 Ω	
<b>Resolution</b>	1/4095 (full scale)	
<b>PLC signal</b>	12-bit binary (for bipolar outputs, 11-bit binary + 1 sign bit.)	
<b>Linearity error</b>	±0.1% max.	
<b>Accuracy</b>	±0.2% max. (full scale at 25°C)	
<b>Accuracy temperature coefficient</b>	±100 PPM/°C (full scale)	
<b>Conversion time</b>	2.5 ms max./port	
<b>Conversion cycle</b>	5 ms max.	
<b>Max. PLC write delay</b> (See Note 2.)	1 s	
<b>Conversion method</b>	Sequential comparison	
<b>Max. input signal</b>	Voltage input: ±15 V	
	Current input: ±60 mA	
<b>External connections</b>	Terminal block (not removable)	
<b>Power consumption</b>	500 mA max. at 5 VDC	
<b>Weight</b>	600 g max.	

**Note** The PC write delay is the time required for a change in the input signal to be converted and transferred to the PLC bus.

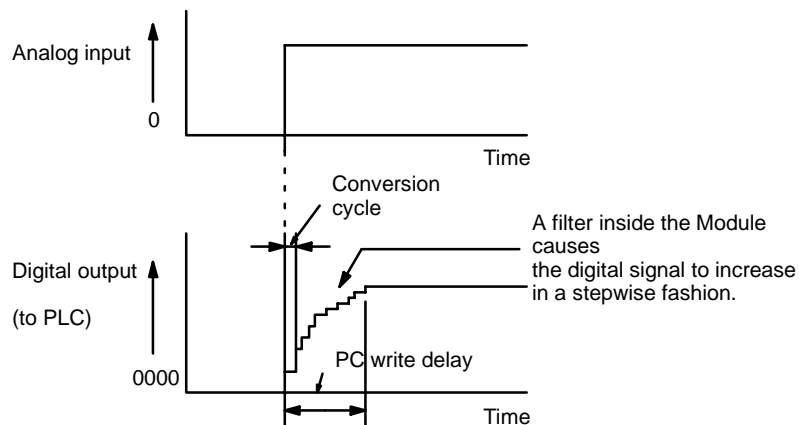

## AD006 and AD007 Analog Input Modules

All general specifications of the AD006 and AD007 Analog Input Modules conform to those of the C Series except the following:

- Insulation resistance between the external terminals and the frame: 5 MΩ min. (at 250 VDC)
- Dielectric strength between the external terminals and the frame: 500 VAC, 50/60 Hz for 1 minute

<b>Number of analog inputs</b>	4	
<b>Input signal range</b> (See Note 1.)	Voltage inputs	0 to 10 V (AD007) 1 to 5 V (AD006)
	Current inputs	4 to 20 mA (AD006)
<b>Input impedance</b>	Voltage input::	1 MW min.
	Current input:	250 W
<b>Resolution</b>	1/1023 (full scale)	
<b>PLC signal</b>	10-bit binary	
<b>Linearity error</b>	±0.2% max.	
<b>Accuracy</b>	±0.2% max. (full scale at 25°C)	
<b>Accuracy temperature coefficient</b>	±150 PPM/°C (full scale)	
<b>Conversion time</b>	2.5 ms max./port	
<b>Conversion cycle</b>	10 ms max.	
<b>Max. PC write delay</b> (See Note 2.)	1 s	
<b>Conversion method</b>	Sequential comparison	
<b>Max. input signal</b>	Voltage input:	±15 V
	Current input:	±60 mA
<b>External connections</b>	Terminal block (not removable)	
<b>Power consumption</b>	750 mA max. at 5 VDC	
<b>Weight</b>	650 g max.	

**Note** The PC write delay is the time required for a change in the input signal to be converted and transferred to the PLC bus.

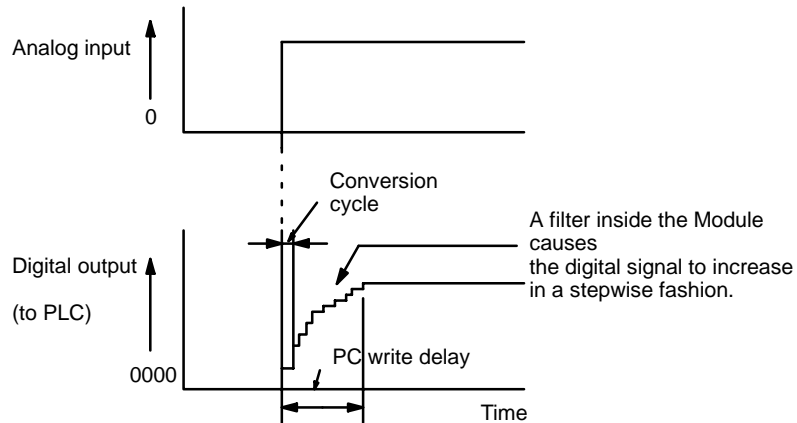

## AD101 Analog Input Module

All general specifications of the AD101 Analog Input Module conform to those of the C Series.

<b>Number of analog inputs</b>	8	
<b>Input signal range</b>	Voltage inputs: 0 to 10 VDC (adjustable) Current inputs: 0 to 20 mA (adjustable)	
<b>Resolution</b> (See Note 1.)	1/4096 max.	
<b>Accuracy</b>	25°C	±0.5% (full scale, including linearity error)
	0 to 55°C	±1.0% (full scale, including linearity error)
<b>Conversion time</b> (See Note 2.)	10 ms max./port	
<b>Input impedance</b>	Voltage input	1 MW min.
	Current input	250 W
<b>Max. input signal</b>	Voltage	±15 V
	Current	±30 mA
<b>PLC signal</b>	12-bit binary	
<b>Number of words</b>	32 or 64 (selectable)	
<b>External connections</b>	30-pin terminal block (not removable)	
<b>Isolation</b>	Between input terminals and PLC: photocoupler	
	Between input terminals and Module: none	
<b>Power consumption</b>	880 mA max. at 5 VDC	
<b>Dimensions</b>	34.5 (W) x 250 (H) x 120 (D) mm	
<b>Weight</b>	700 g max.	

- Note**
1. This is the resolution when the difference between offset and gain is at least 4 V (16 mA). The resolution is less for smaller ranges (e.g., if the difference is 2 V, the resolution is 1/2048).
  2. This is the conversion time when the signal changes from one end of the range to the other. The smaller the signal change, the shorter the conversion time.

## DA001 through DA005 Analog Output Modules

All general specifications of the DA001 through AD005 Analog Output Modules conform to those of the C Series except the following:

- Insulation resistance between the external terminals and the frame: 5 M $\Omega$  min. (at 250 VDC)
- Dielectric strength between the external terminals and the frame: 500 VAC, 50/60 Hz for 1 minute

<b>Number of analog outputs</b>	2	
<b>Output signal range</b>	Voltage outputs	1 to 5 V (DA001)
		0 to 10 V (DA002)
		0 to 5 V (DA003)
		-10 to 10 V (DA004)
		-5 to 5 V (DA005)
	Current outputs	4 to 20 mA (DA001)
<b>Max. output impedance</b>	Voltage output: 0.5 W	
<b>Max. output current</b>	Voltage output: 15 mA	
<b>Max. load resistance</b>	Current output: 550 W	
<b>Resolution</b>	1/4095 (full scale)	
<b>PLC signal</b>	12-bit binary (for bipolar outputs, 11-bit binary + 1 sign bit.)	
<b>Linearity error</b>	$\pm 1/2$ LSB max. (at 25°C)	
<b>Accuracy</b>	$\pm 0.2\%$ max. (full scale, at 25°C)	
<b>Accuracy temperature coefficient</b>	$\pm 50$ PPM/°C	
<b>Conversion time</b>	5 ms max.	
<b>Conversion cycle</b>	PLC program scan time	
<b>External connections</b>	Terminal block (not removable)	
<b>Power consumption</b>	550 mA max. at 5 VDC	
<b>Weight</b>	600 g max.	

## DA101 Analog Output Module

All general specifications of the DA101 Analog Output Module conform to those of the C Series.

<b>Number of analog outputs</b>	4	
<b>Output signal range</b>	Voltage outputs	1 to 5 V
		0 to 10 V
	Current outputs	4 to 20 mA
<b>Resolution</b>	1/4096	
<b>Accuracy</b>	25°C	±0.5% max. (full scale, including linearity error)
	0 to 55°C	±1.0% max. (full scale, including linearity error)
<b>Conversion time (See Note.)</b>	10 ms max.	
<b>Max. output impedance</b>	Voltage output: 0.5 W	
<b>Max. output current</b>	Voltage output: 10 mA	
<b>Max. load resistance</b>	Current output: 400 W	
<b>PLC signal</b>	12-bit binary	
<b>Number of words</b>	64	
<b>External connections</b>	17-pin terminal block (not removable)	
<b>Isolation</b>	Between output terminals and PLC: photocoupler	
	Between output terminals and Module: none	
<b>Power consumption</b>	1.3 A max. 5 VDC	
<b>Dimensions</b>	34.5 (W) x 250 (H) x 113 (D) mm	
<b>Weight</b>	650 g max.	

**Note** This is the conversion time when the signal changes from one end of the range to the other. The smaller the signal change, the shorter the conversion time.





# Index

## A

- AD001 – AD005 Analog Input Modules
  - A/D conversion, 28
  - block diagram, 28
  - dimensions, 12
  - IR bit allocations, 29
  - programming, 48
  - specifications, 75
  - wiring, 13
  - word allocations, 4
- AD006 – AD007 Analog Input Modules
  - A/D conversion, 30
  - block diagram, 30
  - dimensions, 15
  - IR bit allocations, 31
  - programming, 50
  - specifications, 76
  - wiring, 16
  - word allocations, 4
- AD101 Analog Input Modules, 6
  - block diagram, 32
  - data reading area, 38
  - Intelligent I/O Write, 35
  - PLC communications, 34
  - specifications, 77
  - word allocations, 4
  - word setting, 6
  - A/D conversion, 32
  - data writing area, 36
  - dimensions, 18
  - four-word operation, 39, 59
  - input and conversion, 33
  - input ranges, 6
  - Intelligent I/O Read, 38
  - operation mode, 6
  - operational flow, 33
  - peak read bit, 35
  - peak reset bit, 35
  - programming, 52
  - two-word operation, 33, 52
  - unconfirmed data, 35
  - wiring, 18

## B

- basic configuration, 2

## C

- configuration examples, 3

## D

- DA001 – DA005 Analog Output Modules
  - bipolar output, 42
  - block diagram, 41
  - D/A conversion, 41
  - dimensions, 21
  - IR bit allocations, 43
  - programming, 69
  - specifications, 78
  - unipolar output, 41
  - wiring, 22
  - word allocations, 4
- DA101 Analog Output Modules, 9
  - block diagram, 44
  - conversion and output, 44
  - dimensions, 24
  - DIP switches, 9
  - IR bit allocations, 46
  - operational overflow, 45
  - program for BCD data, 71
  - program for binary data, 72
  - programming, 71
  - specifications, 79
  - unipolar output, 41
  - wiring, 24
  - word allocations, 4

## S

- Standard Models
  - Analog Input Modules, 73
  - Analog Output Modules, 73
  - Expansion I/O Racks, 73
- system configuration
  - basic, 2
  - samples, 3

## W

- wiring
  - AD101 Analog Input Modules, 18
  - DA001 – DA005 Analog Output Modules, 22
  - AD001 – AD005 Analog Input Modules, 13
  - AD006 – AD007 Analog Input Modules, 16
  - DA101 Analog Output Modules, 24
- word allocations, 3



## Revision History

# C120/C500/C1000H/C2000H

## Analog I/O Modules

A manual revision code appears as a suffix to the catalog number on the front cover of the manual.

Cat. No. W121-E3-1

↑  
Revision code

The following table outlines the changes made to the manual during each revision. Page numbers refer to the previous version.

Revision code	Date	Revised content
E1-3	June 1991	AD001 through AD005 added. TR bits and mnemonic code added to programs. <b>Page 6:</b> CPU model numbers corrected in caution. <b>Page 30 :</b> Bottom model number corrected and dimension changed from 100 to 103 in bottom graphic. <b>Pages 32, 34:</b> "kW" corrected to "kW." <b>Page 35:</b> Model numbers corrected in headings. <b>Page 41:</b> Operand corrected in third ANDW(34). <b>Page 44:</b> "61115" corrected to "6115" and operand in first MOV(21) corrected. <b>Page 45:</b> Instruction names and function codes corrected. <b>Page 56:</b> Function code corrected for BID and operand corrected in bottom OUT. <b>Page 59:</b> PC-Analog I/O Unit applicability corrected.
E3-1	June 1996	Major Revision for Section 3. Wiring drawings were updated for accuracy.



## OMRON ELECTRONICS LLC

1 Commerce Drive  
Schaumburg, IL 60173  
847.843.7900  
For US technical support or  
other inquiries: 800.556.6766

## OMRON CANADA, INC.

885 Milner Avenue  
Toronto, Ontario M1B 5V8  
416.286.6465

## OMRON ON-LINE

Global - <http://www.omron.com>  
USA - <http://www.omron.com/oei>  
Canada - <http://www.omron.ca>

### UNITED STATES

To locate a Regional Sales Office, local Distributor or  
to obtain product information, call: 847.843.7900

### CANADA REGIONAL SALES OFFICES

<b>Ontario</b>	Toronto	416.286.6465
	Kitchener	519.896.1144
	Kingston	613.376.3968
<b>Quebec</b>	Montreal	514.636.6676
<b>British Columbia</b>	Vancouver	604.522.8855
<b>Alberta</b>	Edmonton	403.440.0818
	Calgary	403.257.3095

### BRAZIL SALES OFFICE

**Sao Paulo** 55.11.5564.6488

### ARGENTINA SALES OFFICE

**Cono Sur** 54.114.787.1129

### MEXICO SALES OFFICES

**Florida** 954.227.2121      **Ciudad Juarez** 656.623.7083  
**Mexico, D.F.** 555.534.1195      **Monterrey, N.L.** 818.377.4281



Компания «ЭлектроПласт» предлагает заключение долгосрочных отношений при поставках импортных электронных компонентов на взаимовыгодных условиях!

Наши преимущества:

- Оперативные поставки широкого спектра электронных компонентов отечественного и импортного производства напрямую от производителей и с крупнейших мировых складов;
- Поставка более 17-ти миллионов наименований электронных компонентов;
- Поставка сложных, дефицитных, либо снятых с производства позиций;
- Оперативные сроки поставки под заказ (от 5 рабочих дней);
- Экспресс доставка в любую точку России;
- Техническая поддержка проекта, помощь в подборе аналогов, поставка прототипов;
- Система менеджмента качества сертифицирована по Международному стандарту ISO 9001;
- Лицензия ФСБ на осуществление работ с использованием сведений, составляющих государственную тайну;
- Поставка специализированных компонентов (Xilinx, Altera, Analog Devices, Intersil, Interpoint, Microsemi, Aeroflex, Peregrine, Syfer, Eurofarad, Texas Instrument, Miteq, Cobham, E2V, MA-COM, Hittite, Mini-Circuits, General Dynamics и др.);

Помимо этого, одним из направлений компании «ЭлектроПласт» является направление «Источники питания». Мы предлагаем Вам помощь Конструкторского отдела:

- Подбор оптимального решения, техническое обоснование при выборе компонента;
- Подбор аналогов;
- Консультации по применению компонента;
- Поставка образцов и прототипов;
- Техническая поддержка проекта;
- Защита от снятия компонента с производства.



#### Как с нами связаться

**Телефон:** 8 (812) 309 58 32 (многоканальный)

**Факс:** 8 (812) 320-02-42

**Электронная почта:** [org@eplast1.ru](mailto:org@eplast1.ru)

**Адрес:** 198099, г. Санкт-Петербург, ул. Калинина, дом 2, корпус 4, литера А.