

**PROPER USE GUIDELINES**

Cumulative Trauma Disorders can result from the prolonged use of manually powered hand tools. Hand tools are intended for occasional use and low volume applications. A wide selection of powered application equipment for extended-use, production operations is available.

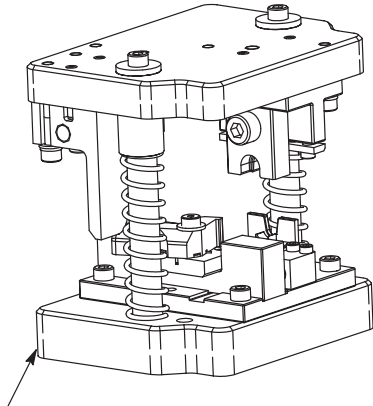

Tooling Assemblies 1901262-[ ]  
for FAKRA □ SMB Gen-4 Connectors

□ DIN Standardization Committee Of Motor Vehicles (FAKRA) 70010

Figure 1

**1. INTRODUCTION**

This instruction sheet covers the application tooling for the ferrule crimps of FAKRA SMB Gen-4 (Generation 4) Connectors.

Tooling Assembly 1901262-1 is used to crimp 90 degree ferrules to coaxial cable; Tooling Assembly 1901262-2 is used to crimp straight (180 degree) ferrules to coaxial cable. See Figure 1.

The tooling is designed to allow the operator to hold the crimped wire and center contact in position in the subassembly while crimping the ferrule

**NOTE** *Dimensions in this instruction sheet are in millimeters. Figures and illustrations are for reference only and are not drawn to scale.*

The product information for these connectors can be found in Application Specification 114-13157.

Reason for revision is given in Section 5, REVISION SUMMARY.

**2. DESCRIPTION**

This tooling is for use in Manual Arbor Frame Assemblies that are capable of 3000 pounds of crimp force.

The “die set open” height for 1901262-[ ] is 123 mm; the “die set closed” height is 97 mm.

The approximate crimp force required to terminate the ferrules is 3000 pounds (based on the Snap-Lock 90 degree Ferrule for RG-71 wire).

The arbor frame assembly must be outfitted with stops. Otherwise the die set (tooling assembly) must be clamped in the arbor frame to prevent it from movement during operation. Place the appropriate die set in the arbor frame being sure to center the ram of the termination tool over the crimp tooling. Do not center the ram over the top of the die set. Proper centering is required to ensure that the tooling bottoms. See Figure 2.

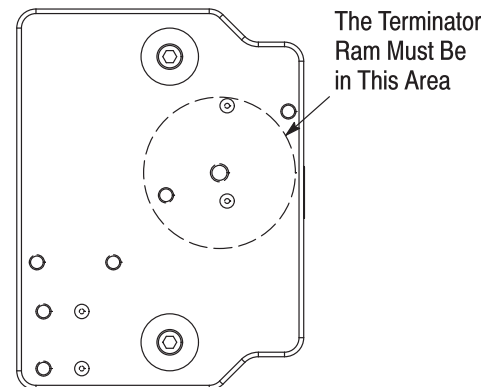

Figure 2

**3. APPLICATION PROCEDURE**

**3.1. Stripping the Coaxial Cable**

Slide the ferrule onto the cable (see Figure 3 ). Be careful to NOT nick or cut the center conductor or the cable braid.

**3.2. Crimping the Plug Connector and Jack Connector**

**NOTE** *For detailed application requirements, refer to Application Specification 114-13157.*

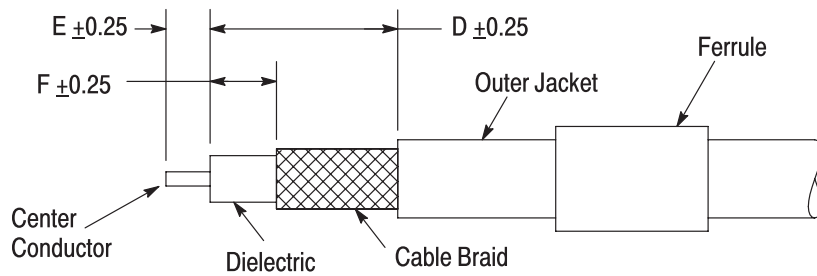

Figure 3

1. Crimp the pin contact (jack connector), or socket contact (plug connector), onto the coaxial cable center conductor using the specific tooling referenced in Application Specification 114-13157.
2. Insert the crimped pin or socket contact into the correct subassembly until it snaps in place. The contact will be held in place by the dielectric prior to crimping the ferrule.
3. Flare the cable braid.



*Be certain that the cable braid is positioned over the tail end of the subassembly. Refer to Figure 4.*

### 3.3. Crimping the Ferrule

1. Slide the ferrule over the the cable braid until the ferrule butts against the shoulder of the assembly. See Figure 5.

2. Crimp the ferrule onto the coaxial cable as follows:

- a. Place the assembled wire and ferrule combination in the die set (tooling set).
- b. Using the locating plate, place the plug or jack connector in the proper position. See Figure 6.



*The ferrule should be located over the anvil.*

- c. Cycle the Arbor Frame. As the frame closes, a cam will push the clamp assembly against the wire, then push the clamp arm until the assembly bottoms (approximately 0.89 mm).
- d. BE SURE the crimper bottoms on the anvil to achieve the correct crimp height. (The correct crimp height is 6.807 +/- 0.2032).

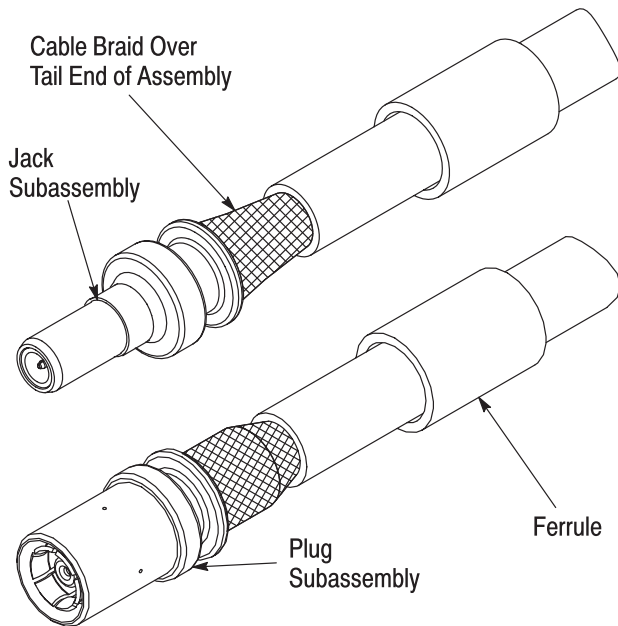

Figure 4

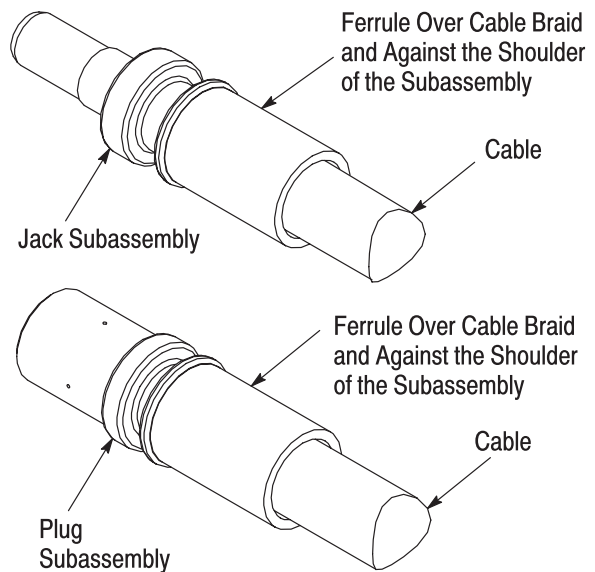

Figure 5

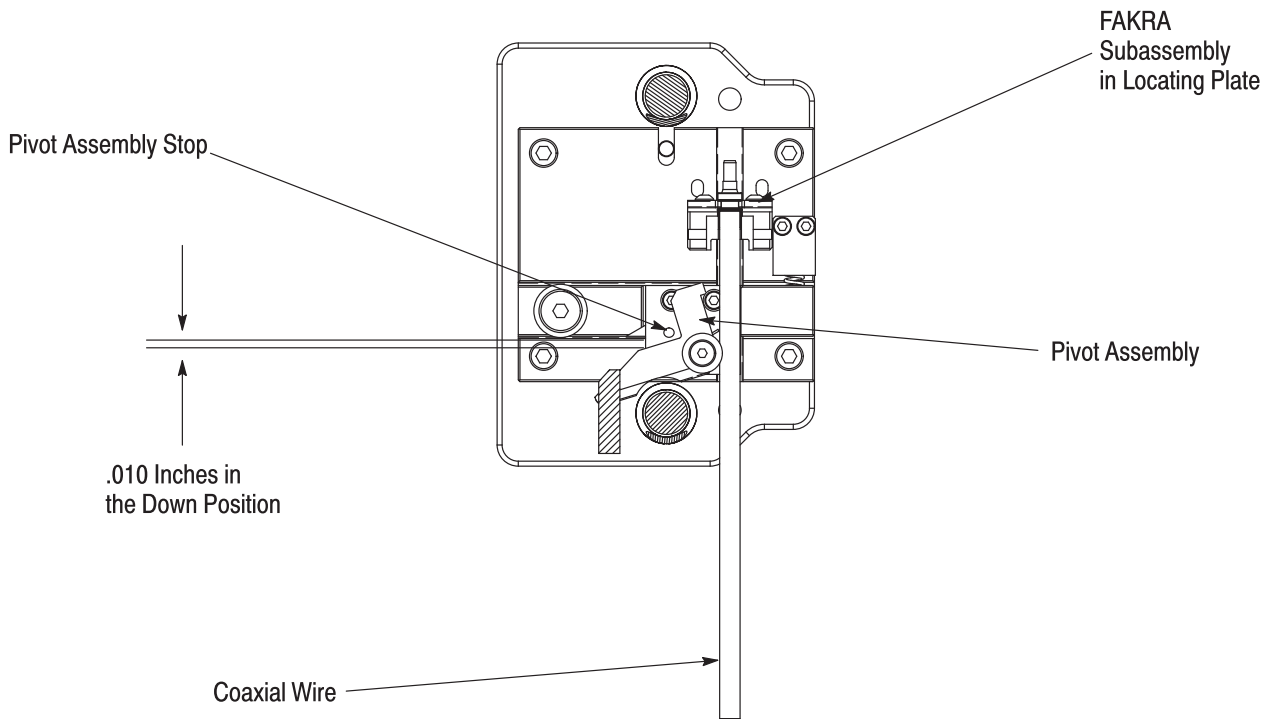

Figure 6

#### 4. PREVENTIVE MAINTENANCE

##### 4.1. Cleaning

Debris can build up around crimp area during normal use. After EACH use, wipe any dust or debris from the die sets.

##### 4.2. Re-Alignment

- a. If crimp tooling is moved, it must be re-aligned before crimping. With tooling loose, carefully bring the upper tooling down to mate with the lower tooling. Align the crimper and anvil. Then tighten the securing screws.
- b. Adjust the cam. The cam should be adjusted to pivot the clamp assembly without binding. Loosen the cam mounting bolts and move the adjustment bolt until the cam positions the pivot assembly approximately .010 inches from the stop. Refer to Figure 6 and Figure 7.

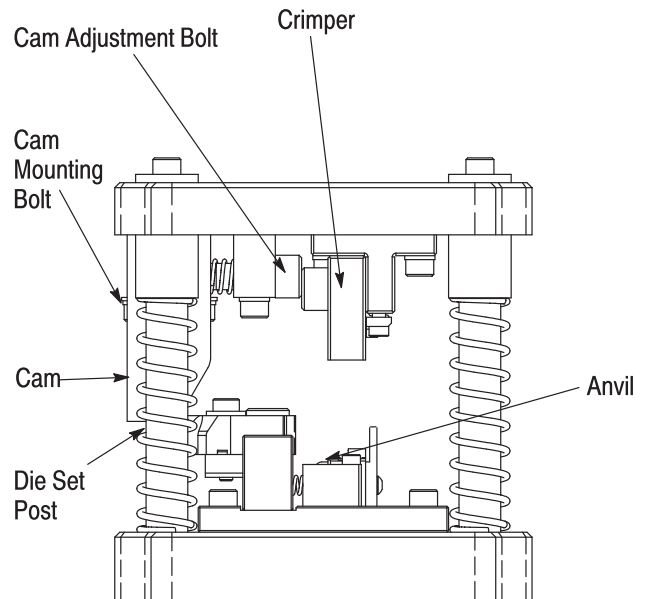

Figure 7

##### 4.3. Lubrication

The die set post (Figure 7) should be coated with light oil before every usage to help prevent binding and wear.

#### 5. REVISION SUMMARY

- Updated document to corporate requirements, including the new corporate logo



Компания «ЭлектроПласт» предлагает заключение долгосрочных отношений при поставках импортных электронных компонентов на взаимовыгодных условиях!

Наши преимущества:

- Оперативные поставки широкого спектра электронных компонентов отечественного и импортного производства напрямую от производителей и с крупнейших мировых складов;
- Поставка более 17-ти миллионов наименований электронных компонентов;
- Поставка сложных, дефицитных, либо снятых с производства позиций;
- Оперативные сроки поставки под заказ (от 5 рабочих дней);
- Экспресс доставка в любую точку России;
- Техническая поддержка проекта, помощь в подборе аналогов, поставка прототипов;
- Система менеджмента качества сертифицирована по Международному стандарту ISO 9001;
- Лицензия ФСБ на осуществление работ с использованием сведений, составляющих государственную тайну;
- Поставка специализированных компонентов (Xilinx, Altera, Analog Devices, Intersil, Interpoint, Microsemi, Aeroflex, Peregrine, Syfer, Eurofarad, Texas Instrument, Miteq, Cobham, E2V, MA-COM, Hittite, Mini-Circuits, General Dynamics и др.);

Помимо этого, одним из направлений компании «ЭлектроПласт» является направление «Источники питания». Мы предлагаем Вам помощь Конструкторского отдела:

- Подбор оптимального решения, техническое обоснование при выборе компонента;
- Подбор аналогов;
- Консультации по применению компонента;
- Поставка образцов и прототипов;
- Техническая поддержка проекта;
- Защита от снятия компонента с производства.



#### Как с нами связаться

**Телефон:** 8 (812) 309 58 32 (многоканальный)

**Факс:** 8 (812) 320-02-42

**Электронная почта:** [org@eplast1.ru](mailto:org@eplast1.ru)

**Адрес:** 198099, г. Санкт-Петербург, ул. Калинина, дом 2, корпус 4, литера А.