

EVALUATION BOARD for WYSBMVGXB (WBSBMVGXB-1)

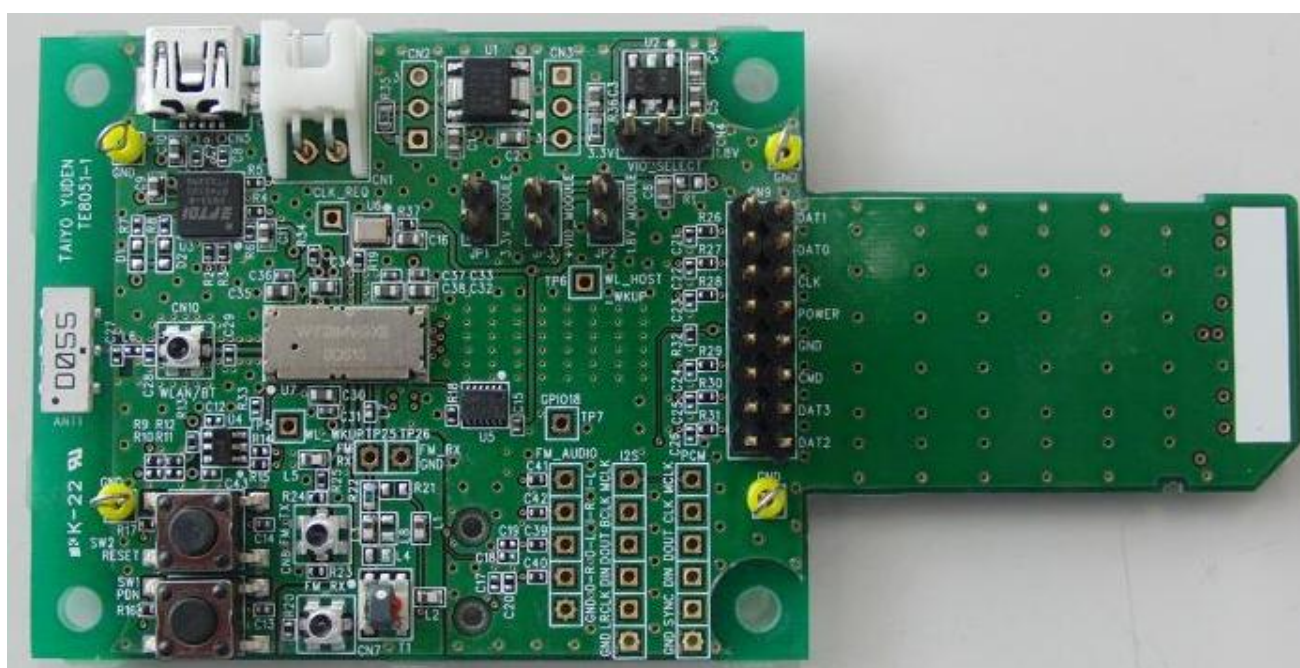

This evaluation board is an object for experiment of operation, and does not guarantee quality. Moreover, the conditions of a module of operation is not recommended in the schematic, the parts, the software, etc. currently used for evaluation board.

The **Bluetooth**[®] word mark and logos are owned by the **Bluetooth** SIG, Inc. and any use of such marks by TAIYO YUDEN CO., LTD. is under license.

TABLE OF CONTENTS

<u>Introduction</u>	3
<u>Mounted module</u>	3
<u>Accessories</u>	3
<u>Example of connection</u>	4
<u>Hardware recommendations</u>	5
<u>Software</u>	5
<u>Evaluation board layout</u>	6
<u>Pin description of evaluation board</u>	7 - 8
<u>BOM of evaluation board</u>	9 - 12
<u>Schematic of evaluation board</u>	13 - 15

Rev. Record

18-Apr. 2011> Ver.0.10 Draft

29-Jul. 2011> Ver.1.00

Introduction

This evaluation board is developed for communication test of **WLAN and Bluetooth[®] (FM)** module which TAIYO YUDEN develops and sells.

This evaluation board makes it possible to perform easily the communication test of **WLAN and Bluetooth[®] (FM)** module of TAIYO YUDEN.

Mounted module

- WBSBMVGXB (2.4GHz / 5GHz dual band WLAN 11a/b/g/n ,BT, (FM))

Note* FM function is not available. Please let us know if you use FM function.

Accessories

1	DC power supply cable	1 piece
---	-----------------------	---------

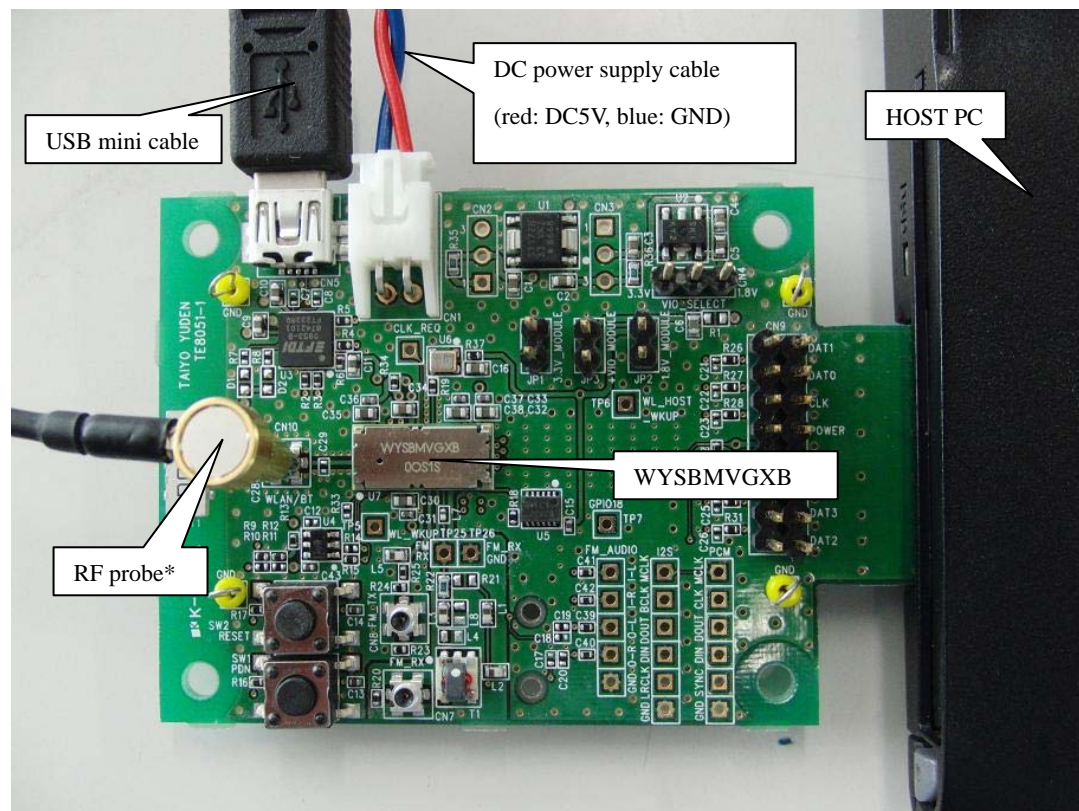
Example of connection

*RF probe : MM126036(MURATA) / MXHS83QE3000(MURATA) / MXHS83QH3000(MURATA) or equivalent

Operating procedure:

- (1) Supply 5.0V DC to the evaluation board.
 - (2) Insert the evaluation board to the host PC's SDIO slot.
 - (3) Insert USB mini cable to evaluation board and HOST PC if you use UART interface to control Bluetooth or (FM) function
 - (4) Execute the application software on host PC.
- (If you fail to follow the right order, the Evaluation Board will not work.)**

Notes:

- (1) This Evaluation Board supports USB I/F and SDIO I/F. USB-UART converter is built in the board. USB-UART converter is FT232R made by Future Technology Devices International Limited. Download USB driver from following URL.
<http://www.ftdichip.com/Support/Knowledgebase/index.html>
- (2) This Evaluation Board is only used for RF evaluation.

Hardware Recommendations

HOST PC Specifications;

CPU : 1000MHz or higher

RAM: 500MB or more

I/F : USB, SDIO

For example : IBM Think Pad X40 / IBM Think Pad X60,X61

Note : If you use host PC with Windows XP, Service pack 3 is required.

DC POWER SUPPLY Specifications;

Input voltage is 3.6 – 5.5V. Current Limit setting should be more than 1A.

Software

- Application software for module evaluation is packaged into CD-ROM.
- Usage of 88W8787 application software and the way to install the 88W8787 driver are described in the manuals.

WBSBMVGXB-1

TAIYO YUDEN Confidential
& Tentative

Evaluation board layout

Board size : 102 mm x 50 mm

102mm

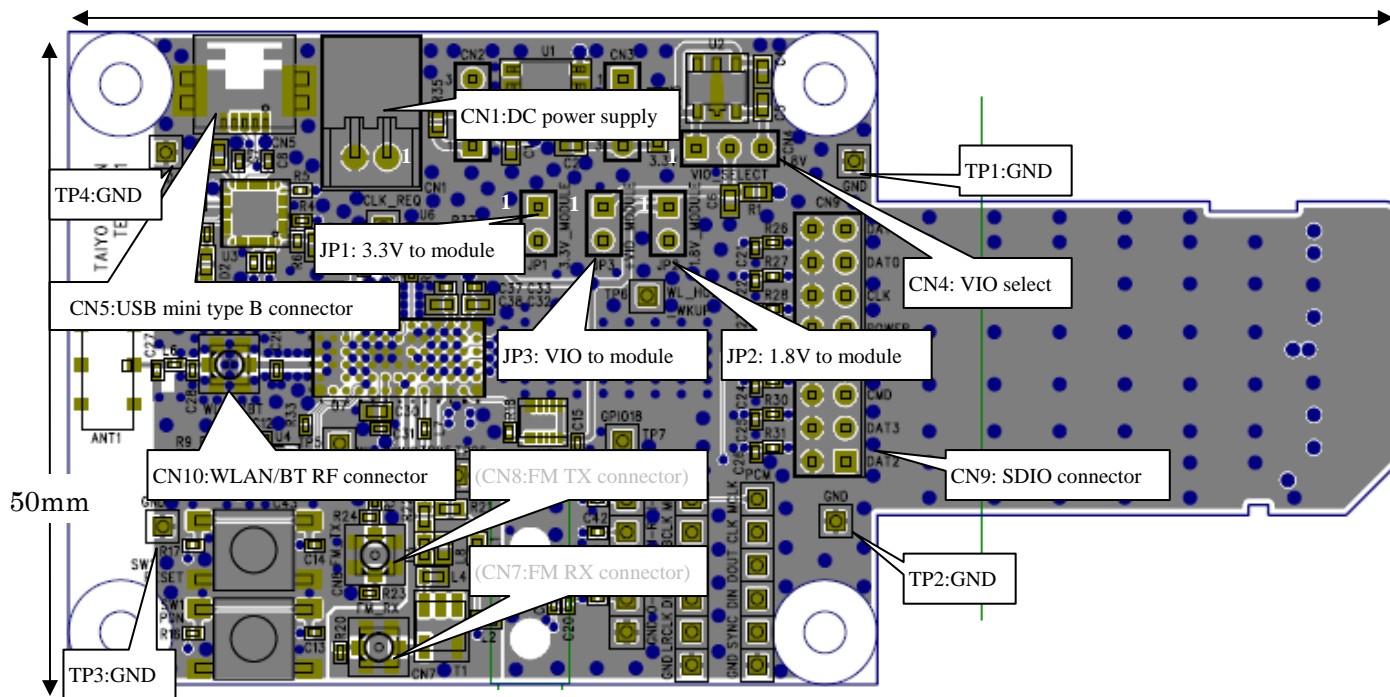

Pin description of evaluation board

JP1: 3.3V to module

No.	Pin name	Direction	Description
1		Output	3.3V output
2		input	3.3V input to the module

JP2: 1.8V to module

No.	Pin name	Direction	Description
1		Output	1.8V LDO output
2		input	1.8V input to the module

JP3: VIO to module

No.	Pin name	Direction	Description
1		Output	3.3V or 1.8V output
2		input	VIO Input to the module

CN1: DC Power Supply

No.	Pin name	Direction	Description
1	5V	Input	3.6 to 5.5V DC Power input.
2	GND	-	VIO Input to the module

CN4: VIO select (1.8V / 3.3V)

No.	Pin name	Direction	Description
1		Output	3.3V power rail
2		Input	Input power to VIO
3		Output	1.8V power rail

Note: VIO input voltage level should be same as HOST computer's IO voltage. According to the host, you need to adjust VIO input voltage level. (If you use Windows PC, VIO input setting is 3.3V normally.)

CN5: USB mini type B connector

No.	Pin name	Direction	Description
1	VBUS	Input	USB power from host
2	D-	Input/Output	USB data line minus
3	D+	Input/Output	USB data line plus
4	ID	-	-
5	GND	-	Ground

WBSBMVGXB-1TAIYO YUDEN Confidential
& Tentative

CN9:SDIO connector

No.	Pin name	Direction	Description
1	SD_DATA2	Input/Output	SDIO Data Line 2
2	GND	-	Ground
3	SD_DATA3	Input/Output	SDIO Data Line 3
4	GND	-	Ground
5	SD_CMD	Input/Output	SDIO COMMAND
6	GND	-	Ground
7	GND	-	Ground
8	GND	-	Ground
9	SDIO_POWER	Output	SDIO Power from host
10	GND	-	Ground
11	SD_CLK	Input	SDIO Clock
12	GND	-	Ground
13	SD_DATA0	Input/Output	SDIO Data Line 0
14	GND	-	Ground
15	SD_DATA1	Input/Output	SDIO Data Line 1
16	GND	-	Ground

(CN7:FM_RX connector)

Pin name	Direction	Description
FM_RX*	Input	FM_RX Radio In

(CN8:FM_TX connector)

Pin name	Direction	Description
FM_TX*	Output	FM_TX Radio Out

CN10:WLAN/BT RF connector

Pin name	Direction	Description
WLAN BT*	Output/Input	WLAN BT Radio Out

*You need to connect RF probe listed below when you measure the RF characteristics.

Recommended RF probe ;

MM126036(MURATA) / MXHS83QE3000(MURATA) / MXHS83QH3000(MURATA) or equivalent

*Note: FM function is not available. Please let us know if you use FM function.

WBSBMVGXB-1TAIYO YUDEN Confidential
& Tentative**BOM of evaluation board**

No.	PART NAME	Description	Supplier	Remark
C1	LMK107BJ475KA-T	Capacitor	Taiyo Yuden or equivalent	
C2	LMK107BJ475KA-T	Capacitor	Taiyo Yuden or equivalent	
C3	LMK107BJ475KA-T	Capacitor	Taiyo Yuden or equivalent	
C4	LMK107BJ475KA-T	Capacitor	Taiyo Yuden or equivalent	
C5	LMK107BJ475KA-T	Capacitor	Taiyo Yuden or equivalent	
C6	LMK107BJ475KA-T	Capacitor	Taiyo Yuden or equivalent	
C7	N.M.			
C8	N.M.			
C9	EMK107BJ225KA-T	Capacitor	Taiyo Yuden or equivalent	
C10	EMK107BJ225KA-T	Capacitor	Taiyo Yuden or equivalent	
C11	EMK107BJ225KA-T	Capacitor	Taiyo Yuden or equivalent	
C12	N.M.			
C13	LMK105BJ104KV-F	Capacitor	Taiyo Yuden or equivalent	
C14	LMK105BJ104KV-F	Capacitor	Taiyo Yuden or equivalent	
C15	LMK105BJ104KV-F	Capacitor	Taiyo Yuden or equivalent	
C16	LMK107BJ475KA-T	Capacitor	Taiyo Yuden or equivalent	
C17	N.M.			
C18	N.M.			
C19	N.M.			
C20	N.M.			
C21	N.M.			
C22	N.M.			
C23	N.M.			
C24	N.M.			
C25	N.M.			
C26	N.M.			
C27	N.M.			
C28	HK1005 4N7S	Inductor	Taiyo Yuden or equivalent	
C29	N.M.			
C30	AMK107BJ106MA-T	Capacitor	Taiyo Yuden or equivalent	
C31	UMK105CH100DV-F	Capacitor	Taiyo Yuden or equivalent	
C32	AMK107BJ106MA-T	Capacitor	Taiyo Yuden or equivalent	

WBSBMVGXB-1

TAIYO YUDEN Confidential
& Tentative

C33	UMK105CH100DV-F	Capacitor	Taiyo Yuden or equivalent	
C34	AMK107BJ106MA-T	Capacitor	Taiyo Yuden or equivalent	
C35	AMK107BJ106MA-T	Capacitor	Taiyo Yuden or equivalent	
C36	UMK105CH100DV-F	Capacitor	Taiyo Yuden or equivalent	
C37	UMK105CH100DV-F	Capacitor	Taiyo Yuden or equivalent	
C38	AMK107BJ106MA-T	Capacitor	Taiyo Yuden or equivalent	
C39	MCR01 JPW	Resistor	ROHM or equivalent	
C40	MCR01 JPW	Resistor	ROHM or equivalent	
C41	MCR01 JPW	Resistor	ROHM or equivalent	
C42	MCR01 JPW	Resistor	ROHM or equivalent	
C43	LMK105BJ104KV-F	Capacitor	Taiyo Yuden or equivalent	
R1	N.M.			
R2	MCR01 JPW	Resistor	ROHM or equivalent	
R3	MCR01 JPW	Resistor	ROHM or equivalent	
R4	MCR01 JPW	Resistor	ROHM or equivalent	
R5	MCR01 JPW	Resistor	ROHM or equivalent	
R6	MCR01 102J	Resistor	ROHM or equivalent	
R7	N.M.			
R8	N.M.			
R9	MCR01 JPW	Resistor	ROHM or equivalent	
R10	N.M.			
R11	N.M.			
R12	MCR01 304J	Resistor	ROHM or equivalent	
R13	MCR01 104J	Resistor	ROHM or equivalent	
R14	N.M.			
R15	MCR01 JPW	Resistor	ROHM or equivalent	
R16	MCR01 103J	Resistor	ROHM or equivalent	
R17	MCR01 103J	Resistor	ROHM or equivalent	
R18	MCR01 JPW	Resistor	ROHM or equivalent	
R19	MCR01 JPW	Resistor	ROHM or equivalent	
R20	MCR01 510J	Resistor	ROHM or equivalent	
R21	N.M.			
R22	MCR03 JPW	Resistor	ROHM or equivalent	
R23	MCR01 510J	Resistor	ROHM or equivalent	
R24	MCR01 510J	Resistor	ROHM or equivalent	
R25	MCR01 471J	Resistor	ROHM or equivalent	

WBSBMVGXB-1

TAIYO YUDEN Confidential
& Tentative

R26	MCR01 220J	Resistor	ROHM or equivalent	
R27	MCR01 220J	Resistor	ROHM or equivalent	
R28	MCR01 220J	Resistor	ROHM or equivalent	
R29	MCR01 220J	Resistor	ROHM or equivalent	
R30	MCR01 220J	Resistor	ROHM or equivalent	
R31	MCR01 220J	Resistor	ROHM or equivalent	
R32	MCR01 102J	Resistor	ROHM or equivalent	
R33	N.M.			
R34	MCR01 JPW	Resistor	ROHM or equivalent	
R35	MCR03 JPW	Resistor	ROHM or equivalent	
R36	MCR03 JPW	Resistor	ROHM or equivalent	
R37	MCR01 330J	Resistor	ROHM or equivalent	
L1	HK1608 R22J-T	Inductor	Taiyo Yuden or equivalent	
L2	HK1608 56NJ-T	Inductor	Taiyo Yuden or equivalent	
L3	HK1608 R18J-T	Inductor	Taiyo Yuden or equivalent	
L4	N.M.			
L5	HK1608 R10J-T	Inductor	Taiyo Yuden or equivalent	
L6	EVK105CH010BW-F	Capacitor	Taiyo Yuden or equivalent	
L7	HK1005 R18J-T	Inductor	Taiyo Yuden or equivalent	
L8	N.M.			
CN1	S2B-XH-A	connector	JST or equivalent	
CN2	N.M.			
CN3	N.M.			
CN4	2.54mm PITCH PIN HEADER 3	PIN	HIROSE or equivalent	
CN5	UX60SC-MB-5ST	USB-type B mini	JST or equivalent	
CN6	N.M.			
CN7	MM8430-2600RA1	RF connector	MURATA or equivalent	
CN8	MM8430-2600RA1	RF connector	MURATA or equivalent	
CN9	2.54mm PITCH PIN HEADER 16	PIN	HIROSE or equivalent	
CN10	MM8430-2600RA1	RF connector	MURATA or equivalent	
T1	TC1.5-1+		mini circuit or equivalent	
U1	S-1172B33-E6T1G	3.3V LDO	SII or equivalent	
U2	S-1155B18-U5T1G	1.8V LDO	SII or equivalent	
U3	FT232RQ	USB-UART converter	FTDI or equivalent	
U4	TPS3808G01	reset supervisor IC	T.I. or equivalent	
U5	SG-3030LC	32KHz oscillator	Epson Toyocom or equivalent	

WBSBMVGXB-1TAIYO YUDEN Confidential
& Tentative

U6	TG-5025CG 38.4MHz	TCXO 38.4MHz	Epson Toyocom or equivalent	
U7	WYSBMVGXB	WLAN/BT Module	TAIYO YUDEN	
SW1	HP03-15AFKP	SW	Nikkai or equivalent	
SW2	HP03-15AFKP	SW	Nikkai or equivalent	
D1	N.M.			
D2	N.M.			
JP1	2.54mm PITCH PIN HEADER 2	PIN	HIROSE or equivalent	
JP2	2.54mm PITCH PIN HEADER 2	PIN	HIROSE or equivalent	
JP3	2.54mm PITCH PIN HEADER 2	PIN	HIROSE or equivalent	
TP1	LC-2-S	TP	Sanhayato or equivalent	
TP2	LC-2-S	TP	Sanhayato or equivalent	
TP3	LC-2-S	TP	Sanhayato or equivalent	
TP4	LC-2-S	TP	Sanhayato or equivalent	
ANT1	AH104N2540D1	ANTENNA	Taiyo Yuden or equivalent	

REV	ECO	APPROVED	DESCRIPTION	DATE

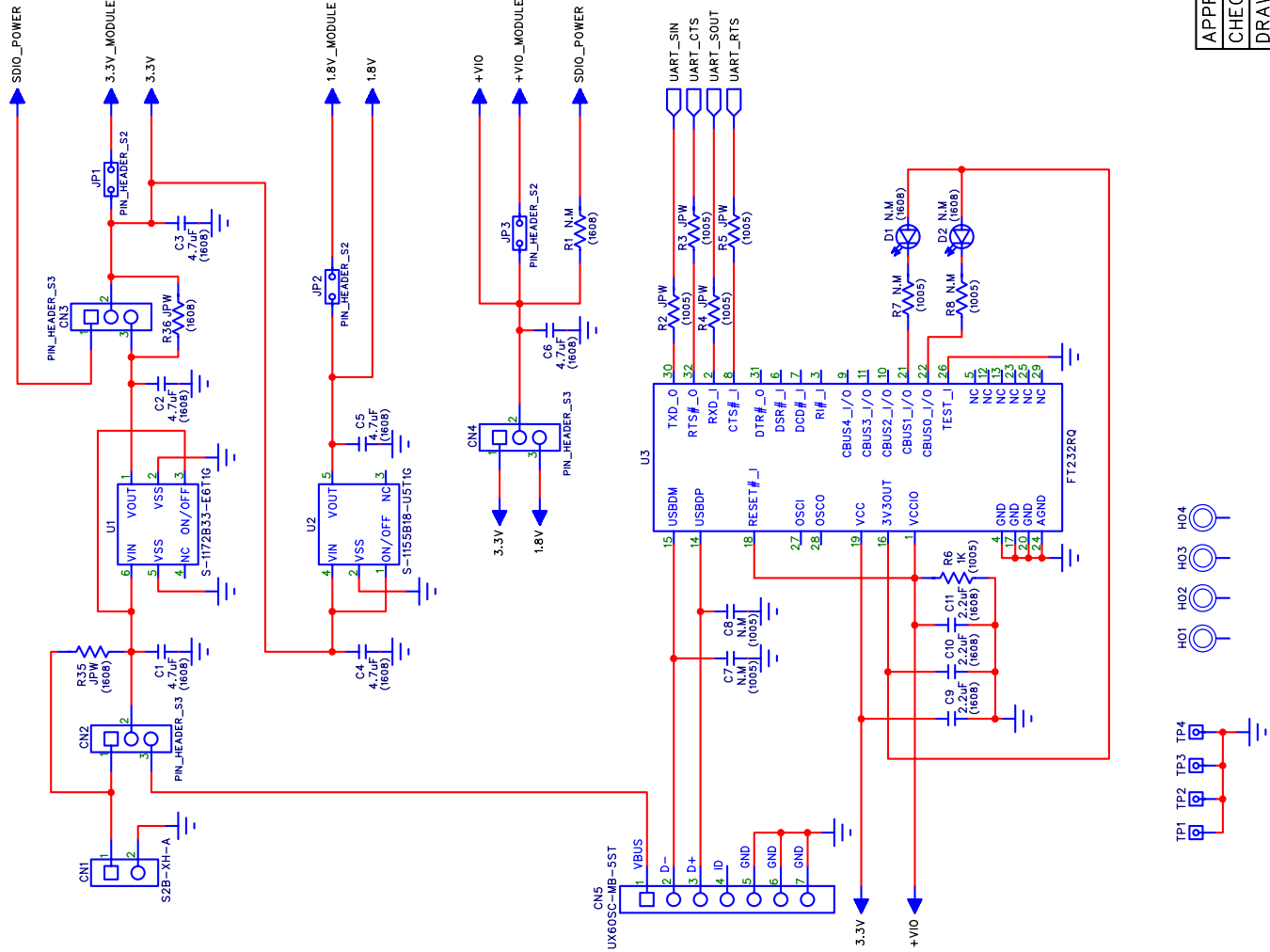

APPROVED:	Document No.
CHECKED :	HD-MC-
DRAWN : 2011/05/27	BTE8051-1
DESIGNED :	(1/3)

	Title
	Circuit schematic

REV	ECO	APPROVED	DESCRIPTION	DATE

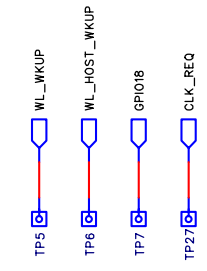
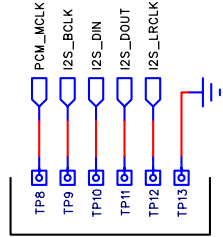
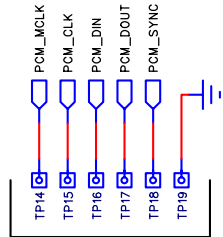
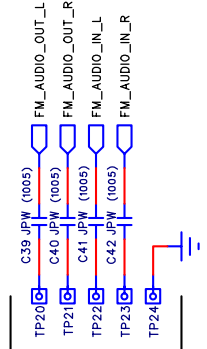
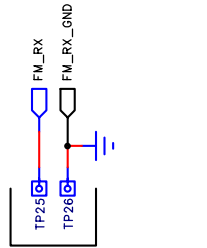
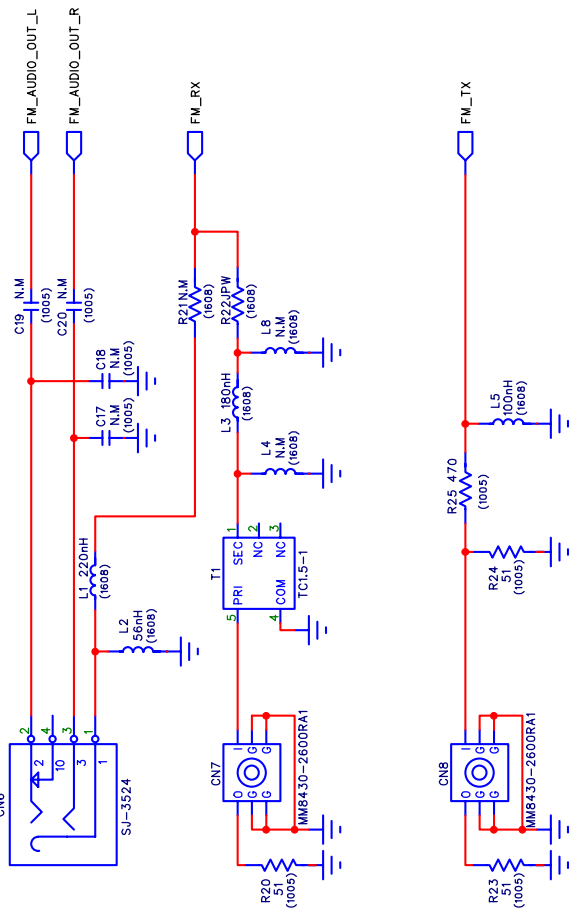
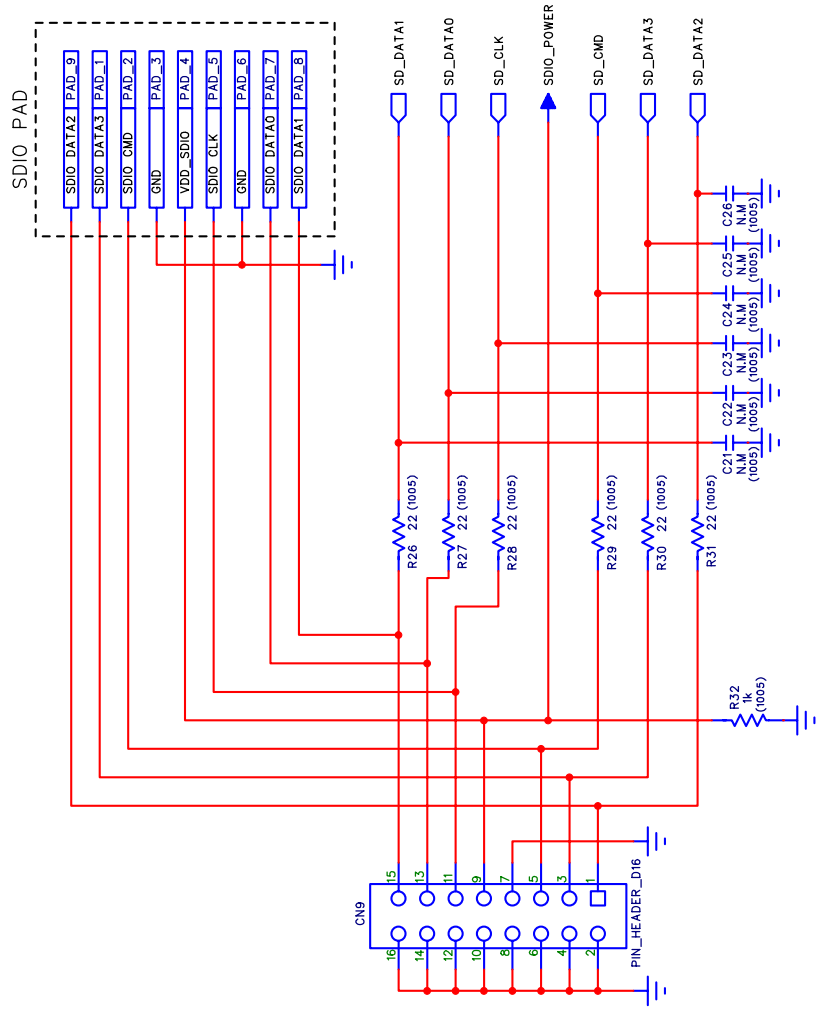

APPROVED:	Title	Document No.
CHECKED :	Circuit schematic	HD-MC-
DRAWN : 2011/05/27		BTE8051-1
DESIGNED :		(2/3)

REV	ECO	APPROVED	DESCRIPTION	DATE

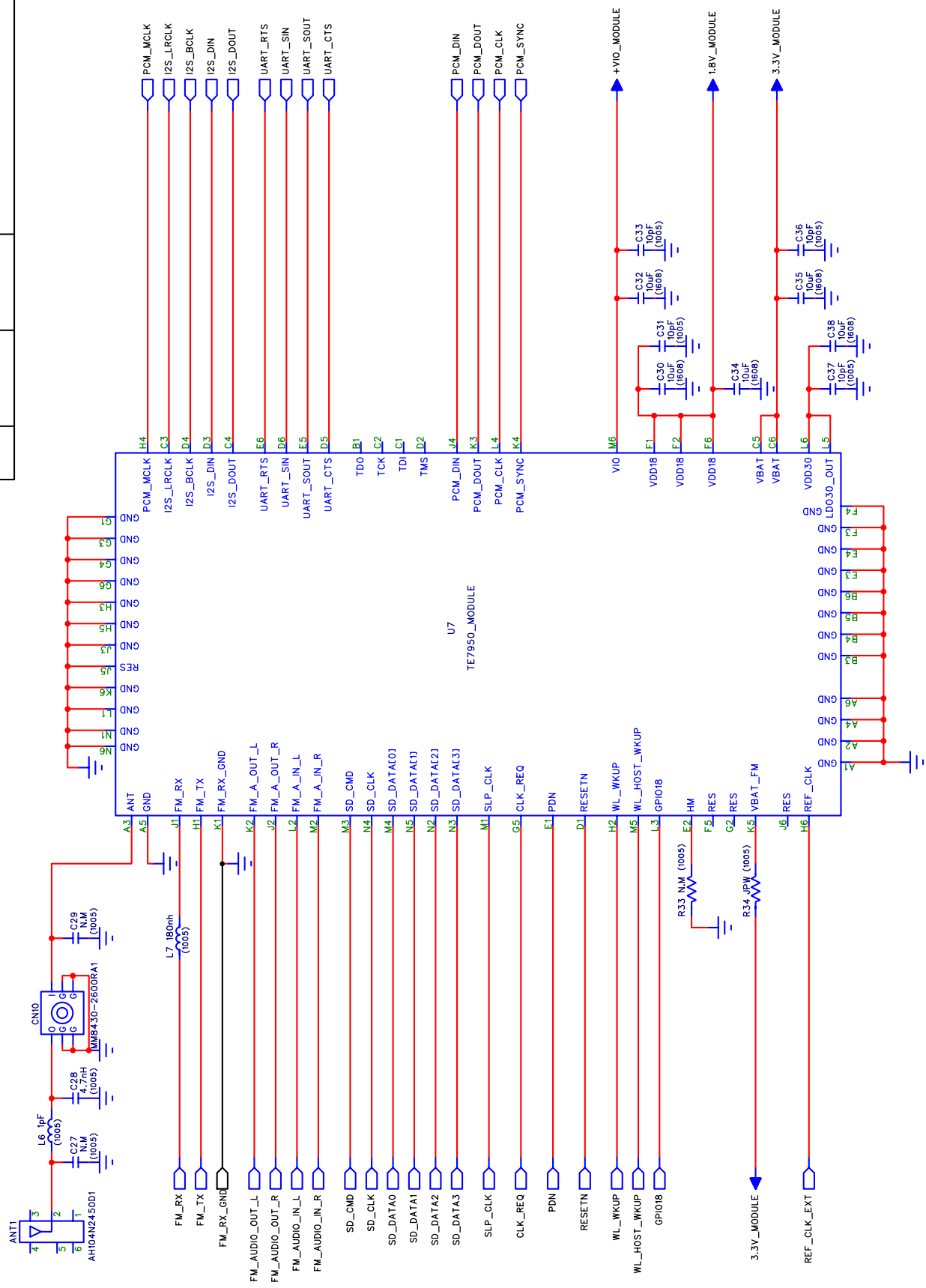

APPROVED:	Title	Document No.
CHECKED :	Circuit schematic	HD-MC-
DRAWN : 2011/05/27		BTE8051-1
DESIGNED :		(3/3)

Mouser Electronics

Authorized Distributor

Click to View Pricing, Inventory, Delivery & Lifecycle Information:

[Taiyo Yuden:](#)

[WBSBMVGXB-1](#)



Компания «ЭлектроПласт» предлагает заключение долгосрочных отношений при поставках импортных электронных компонентов на взаимовыгодных условиях!

Наши преимущества:

- Оперативные поставки широкого спектра электронных компонентов отечественного и импортного производства напрямую от производителей и с крупнейших мировых складов;
- Поставка более 17-ти миллионов наименований электронных компонентов;
- Поставка сложных, дефицитных, либо снятых с производства позиций;
- Оперативные сроки поставки под заказ (от 5 рабочих дней);
- Экспресс доставка в любую точку России;
- Техническая поддержка проекта, помощь в подборе аналогов, поставка прототипов;
- Система менеджмента качества сертифицирована по Международному стандарту ISO 9001;
- Лицензия ФСБ на осуществление работ с использованием сведений, составляющих государственную тайну;
- Поставка специализированных компонентов (Xilinx, Altera, Analog Devices, Intersil, Interpoint, Microsemi, Aeroflex, Peregrine, Syfer, Eurofarad, Texas Instrument, Miteq, Cobham, E2V, MA-COM, Hittite, Mini-Circuits, General Dynamics и др.);

Помимо этого, одним из направлений компании «ЭлектроПласт» является направление «Источники питания». Мы предлагаем Вам помощь Конструкторского отдела:

- Подбор оптимального решения, техническое обоснование при выборе компонента;
- Подбор аналогов;
- Консультации по применению компонента;
- Поставка образцов и прототипов;
- Техническая поддержка проекта;
- Защита от снятия компонента с производства.



Как с нами связаться

Телефон: 8 (812) 309 58 32 (многоканальный)

Факс: 8 (812) 320-02-42

Электронная почта: org@eplast1.ru

Адрес: 198099, г. Санкт-Петербург, ул. Калинина, дом 2, корпус 4, литера А.