

NHD-320240WG-BoTML-VZ#-030

Graphic Liquid Crystal Display Module

NHD-	Newhaven Display
320240-	320 x 240 pixels
WG-	Display Type: Graphic
Bo-	Model
T-	White LED Backlight
M-	STN- Negative Blue
L-	Transmissive, 12:00 view, Wide Temperature (-20°C ~+70°C)
VZ#-	Built-in Negative Voltage
030-	110mm FFC, Touch panel, JF1, JF2 shorted

RoHS Compliant

Newhaven Display International, Inc.

2511 Technology Drive, Suite 101
Elgin IL, 60124

Ph: 847-844-8795 Fax: 847-844-8796

www.newhavendisplay.com

nhtech@newhavendisplay.com

nhsales@newhavendisplay.com

Document Revision History

Revision	Date	Description	Changed by
0	6/7/2007	Initial Release	-
1	3/15/2010	User guide reformat	MC
2	9/2/2010	Mechanical drawing update	MP

Functions and Features

- 320 x 240 pixels
- Built-in RA8835 Controller
- +5.0V power supply
- RoHS Compliant

Mechanical Drawing

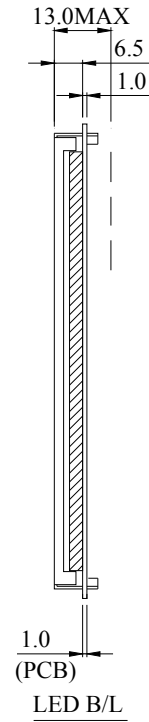
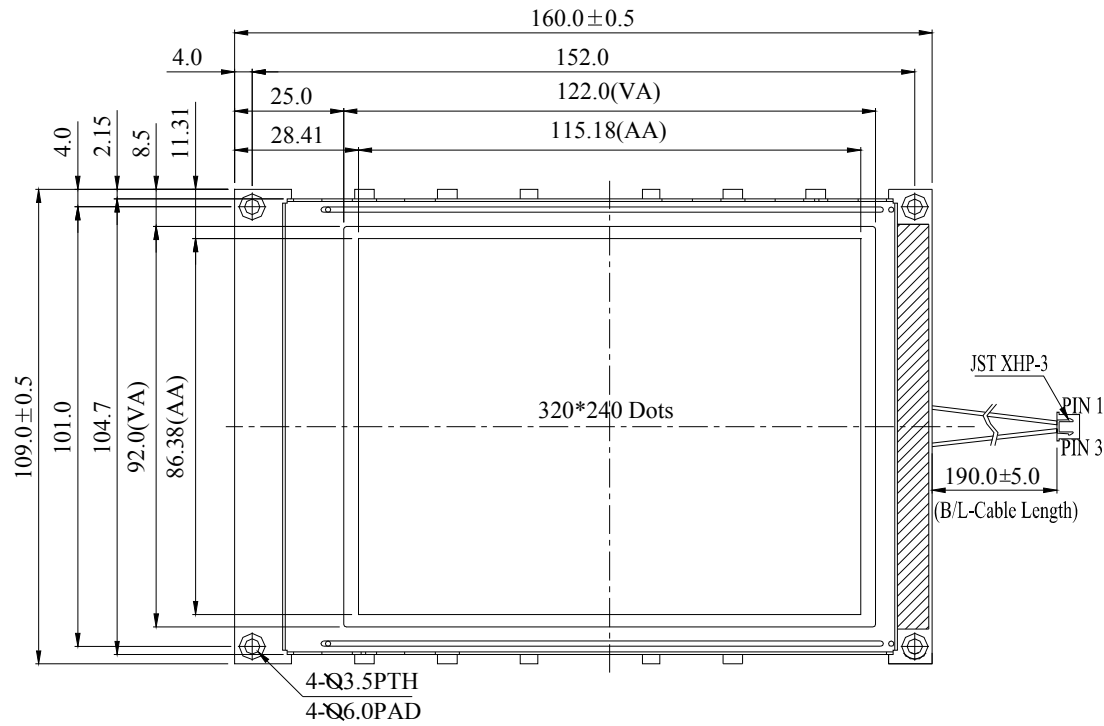

PIN NO.	SYMBOL
1	VSS
2	Vcc
3	Vo
4	A0
5	R/W
6	E
7	DB0
8	DB1
9	DB2
10	DB3
11	DB4
12	DB5
13	DB6
14	DB7
15	/CS
16	/RST
17	Vee
18	NC
19	NC
20	NC

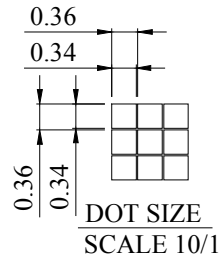

The non-specified tolerance of dimension is $\pm 0.3\text{mm}$.

Newhaven Display

NHD-320240WG-BoTML-VZ#-030

Pin Description and Wiring Diagram

Pin No.	Symbol	External Connection	Function Description
1	VSS	Power Supply	Ground
2	VDD	Power Supply	Power supply for logic (+5.0V)
3	VO	Adj Power Supply	Power supply for contrast (approx. -19.0V)
4	A0	MPU	Register select signal. A0=0: Command, A0=1: Data
5	R/W	MPU	Read/Write select signal, R/W=1: Read R/W: =0: Write
6	E	MPU	Operation enable signal. Falling edge triggered.
7-14	DB0-DB7	MPU	Bi-directional three-state data bus lines.
15	/CS	MPU	Active LOW chip select
16	/RST	MPU	Active LOW reset signal
17	VEE	Power Supply	Negative voltage output (-25V)
18	NC	-	No Connect
19	NC	-	No Connect
20	NC	-	No Connect

Recommended LCD connector: 1.0mm pitch, 20-pos FFC connector

Backlight connector: JST p/n: XHP-3 **Mates with:** JST p/n: B 3B-XH-A

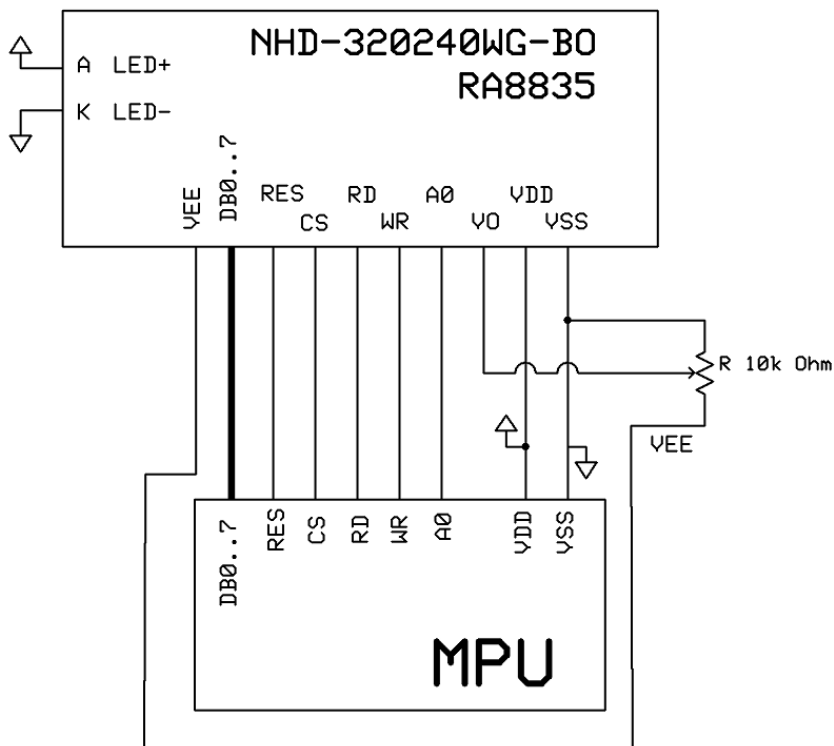

Electrical Characteristics

Item	Symbol	Condition	Min.	Typ.	Max.	Unit
Operating Temperature Range	Top	Absolute Max	-20	-	+70	°C
Storage Temperature Range	Tst	Absolute Max	-30	-	+80	°C
Supply Voltage	VDD		4.5	5.0	5.5	V
Supply Current	IDD	Ta=25°C, VDD=5.0V	95.0	100.0	110.0	mA
Supply for LCD (contrast)	VDD-VLCD	Ta=25°C	22.0	24.0	26.0	V
"H" Level input	VIH		0.5VDD	-	VDD	V
"L" Level input	VIL	-	0	-	0.2VDD	V
"H" Level output	VOH	-	2.4	-	-	V
"L" Level output	VOL	-	-	-	0.4	V
Backlight Supply Voltage	VLED		3.4	3.5	3.6	V
Backlight Supply Current	ILED	VLED=3.5V	120	160	180	mA
Backlight Lifetime		ILED=160mA	-	50,000	-	Hrs

Optical Characteristics

Item	Symbol	Condition	Min.	Typ.	Max.	Unit
Viewing Angle - Vertical	AV	Cr ≥ 3	-20	-	40	°
Viewing Angle - Horizontal	AH	Cr ≥ 3	-30	-	30	°
Contrast Ratio	Cr		-	3	-	-
Response Time (rise)	Tr	-	-	150	200	ms
Response Time (fall)	Tf	-	-	150	200	ms

Controller Information

Built-in RA8835. Download specification at http://www.newhavendisplay.com/app_notes/RA8835.pdf

Table of Commands

Table-1: Command Set

Class	Command	Code											Hex	Command Description	Command Read Parameters	
		RD	WR	A0	D7	D6	D5	D4	D3	D2	D1	D0			No. of Bytes	Section
System Control	SYSTEM SET	1	0	1	0	1	0	0	0	0	0	0	40	Initialize device and display	8	9-2-1
	SLEEP IN	1	0	1	0	1	0	1	0	0	1	1	53	Enter standby mode	0	9-2-2
Display Control	DISPLAY ON/OFF	1	0	1	0	1	0	1	1	0	0	D	58, 59	Enable and disable display and display flashing	1	9-3-1
	SCROLL	1	0	1	0	1	0	0	0	1	0	0	44	Set display start address and display regions	10	9-3-2
	CSRFORM	1	0	1	0	1	0	1	1	1	0	1	5D	Set cursor type	2	9-3-3
	CGRAM ADR	1	0	1	0	1	0	1	1	1	0	0	5C	Set start address of character generator RAM	2	9-3-6
	CSRDIR	1	0	1	0	1	0	0	1	1	CD 1	CD 0	4C to 4F	Set direction of cursor movement	0	9-3-4
	HDOT SCR	1	0	1	0	1	0	1	1	0	1	0	5A	Set horizontal scroll position	1	9-3-7
	OVLAY	1	0	1	0	1	0	1	1	0	1	1	5B	Set display overlay format	1	9-3-5
Drawing Control	CSRW	1	0	1	0	1	0	0	0	1	1	0	46	Set cursor address	2	9-r1
	CSRR	1	0	1	0	1	0	0	0	1	1	1	47	Read cursor address	2	9-4-2
Memory Control	MWRITE	1	0	1	0	1	0	0	0	0	1	0	42	Write to display memory	—	9-5-1
	MREAD	1	0	1	0	1	0	0	0	0	1	1	43	Read from display memory	—	9-5-2

Timing Characteristics

10-3-1 8080 Family Interface Timing

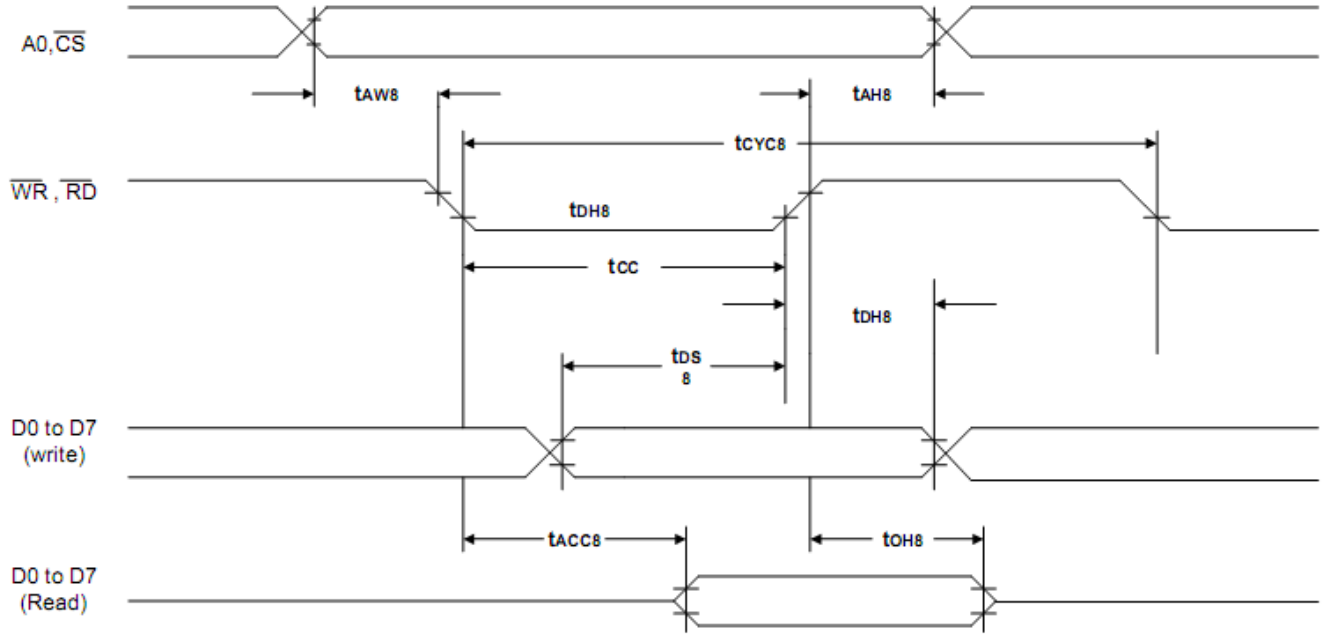

$T_a = -20 \text{ to } 75^\circ\text{C}$

Signal	Symbol	Parameter	$V_{DD} = 4.5 \text{ to } 5.5\text{V}$		$V_{DD} = 2.7 \text{ to } 4.5\text{V}$		Unit	Condition
			Min.	Max.	Min.	Max.		
A0, \overline{CS}	t_{AH8}	Address hold time	10	—	10	—	ns	CL = 100pF
	t_{AW8}	Address setup time	0	—	0	—	ns	
\overline{WR} , \overline{RD}	t_{CYC8}	System cycle time	note.	—	note.	—	ns	
	t_{CC}	Strobe pulse width	120	—	150	—	ns	
D0 to D7	t_{DS8}	Data setup time	120	—	120	—	ns	
	t_{DH8}	Data hold time	5	—	5	—	ns	
	t_{ACC8}	\overline{RD} access time	—	50	—	80	ns	
	t_{OH8}	Output disable time	10	50	10	55	ns	

Note: For memory control and system control commands:

$$t_{CYC8} = 2t_C + t_{CC} + t_{CEA} + 75 > t_{ACV} + 245$$

For all other commands:

$$t_{CYC8} = 4t_C + t_{CC} + 30$$

10-3-2 6800 Family Interface Timing

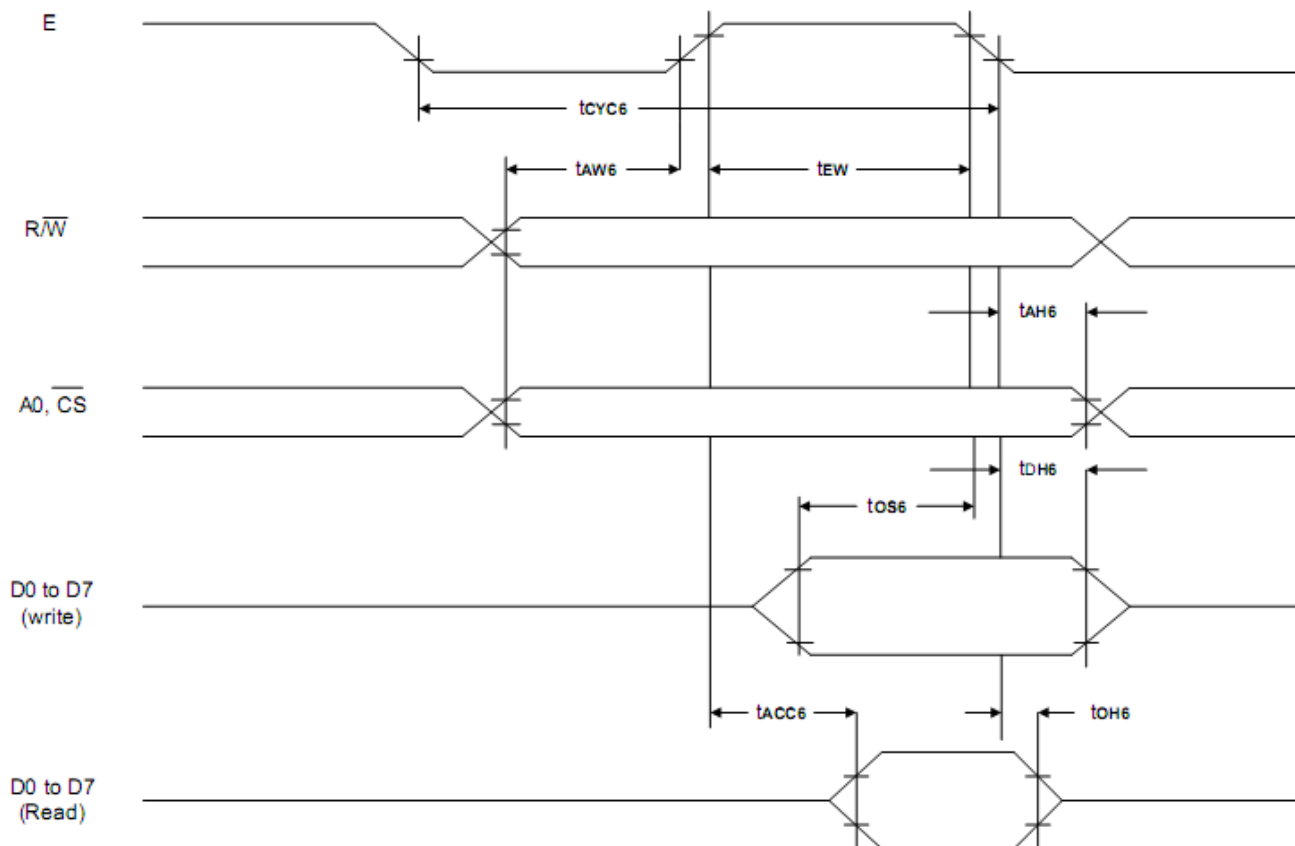

Ta = -20 to 75°C

Signal	Symbol	Parameter	V _{DD} = 4.5 to 5.5V		V _{DD} = 2.7 to 4.5V		Unit	Condition
			Min.	Max.	Min.	Max.		
A0, $\overline{\text{CS}}$, R/(W)	t _{CYC6}	System cycle time	note.	—	note.	—	ns	CL = 100 pF
	t _{AW6}	Address setup time	0	—	10	—	ns	
	t _{AH6}	Address hold time	0	—	0	—	ns	
D0 to D7	t _{DS6}	Data setup time	100	—	120	—	ns	
	t _{DH6}	Data hold time	0	—	0	—	ns	
	t _{OH6}	Output disable time	10	50	10	75	ns	
	t _{ACC6}	Access time	—	85	—	130	ns	
E	t _{EW}	Enable pulse width	120	—	150	—	ns	

Note: For memory control and system control commands:

$$t_{\text{CYC6}} = 2t_{\text{C}} + t_{\text{EW}} + t_{\text{CEA}} + 75 > t_{\text{ACV}} + 245$$

For all other commands:

$$t_{\text{CYC6}} = 4t_{\text{C}} + t_{\text{EW}} + 30$$

Example Initialization Program:

```
//-----  
#define A0 P3_0  
#define RW P3_7  
#define E P3_4  
#define CS P3_1  
#define RESET P3_6  
  
//-----  
void data_out(unsigned char i) //Data Output 16-bit Bus Interface  
{  
    A0 = 0;  
    P1 = i;  
    CS = 0;  
    RW = 0;  
    E = 1;  
    delay(1);  
    E = 0;  
    RW = 1;  
    CS = 1;  
}  
void comm_out(unsigned char j) //Command Output 8-bit Bus Interface  
{  
    A0 = 1;  
    P1 = j;  
    CS = 0;  
    RW = 0;  
    E = 1;  
    delay(1);  
    E = 0;  
    RW = 1;  
    CS = 1;  
}  
  
//-----  
//          Initialization For RA8835  
//-----  
void resetLCD()  
{  
    RESET = 0;  
    delay(5);  
    RESET = 1;  
    delay(10);  
}  
void init_LCD()
```

```
{  
comm_out(0x40);  
delay(5);  
data_out(0x34);  
data_out(0x87);  
data_out(0x07);  
data_out(0x27);  
data_out(0x39);  
data_out(0xEF);  
data_out(0x28);  
data_out(0x00);  
comm_out(0x44);  
data_out(0x00);  
data_out(0x00);  
data_out(0xEF);  
data_out(0xB0);  
data_out(0x04);  
data_out(0xEF);  
data_out(0x00);  
data_out(0x00);  
data_out(0x00);  
data_out(0x00);  
comm_out(0x5A);  
data_out(0x00);
```

Quality Information

Test Item	Content of Test	Test Condition	Note
High Temperature storage	Endurance test applying the high storage temperature for a long time.	+80°C , 200hrs	2
Low Temperature storage	Endurance test applying the low storage temperature for a long time.	-30°C , 200hrs	1,2
High Temperature Operation	Endurance test applying the electric stress (voltage & current) and the high thermal stress for a long time.	+70°C 200hrs	2
Low Temperature Operation	Endurance test applying the electric stress (voltage & current) and the low thermal stress for a long time.	-20°C , 200hrs	1,2
High Temperature / Humidity Operation	Endurance test applying the electric stress (voltage & current) and the high thermal with high humidity stress for a long time.	+60°C , 90% RH , 96hrs	1,2
Thermal Shock resistance	Endurance test applying the electric stress (voltage & current) during a cycle of low and high thermal stress.	-20°C,30min -> 25°C,5min -> 70°C,30min = 1 cycle 10 cycles	
Vibration test	Endurance test applying vibration to simulate transportation and use.	10-55Hz , 15mm amplitude. 60 sec in each of 3 directions X,Y,Z For 15 minutes	3
Static electricity test	Endurance test applying electric static discharge.	VS=800V, RS=1.5kΩ, CS=100pF One time	

Note 1: No condensation to be observed.

Note 2: Conducted after 4 hours of storage at 25°C, 0%RH.

Note 3: Test performed on product itself, not inside a container.

Precautions for using LCDs/LCMs

See Precautions at www.newhavendisplay.com/specs/precautions.pdf

Warranty Information and Terms & Conditions

http://www.newhavendisplay.com/index.php?main_page=terms



Компания «ЭлектроПласт» предлагает заключение долгосрочных отношений при поставках импортных электронных компонентов на взаимовыгодных условиях!

Наши преимущества:

- Оперативные поставки широкого спектра электронных компонентов отечественного и импортного производства напрямую от производителей и с крупнейших мировых складов;
- Поставка более 17-ти миллионов наименований электронных компонентов;
- Поставка сложных, дефицитных, либо снятых с производства позиций;
- Оперативные сроки поставки под заказ (от 5 рабочих дней);
- Экспресс доставка в любую точку России;
- Техническая поддержка проекта, помощь в подборе аналогов, поставка прототипов;
- Система менеджмента качества сертифицирована по Международному стандарту ISO 9001;
- Лицензия ФСБ на осуществление работ с использованием сведений, составляющих государственную тайну;
- Поставка специализированных компонентов (Xilinx, Altera, Analog Devices, Intersil, Interpoint, Microsemi, Aeroflex, Peregrine, Syfer, Eurofarad, Texas Instrument, Miteq, Cobham, E2V, MA-COM, Hittite, Mini-Circuits, General Dynamics и др.);

Помимо этого, одним из направлений компании «ЭлектроПласт» является направление «Источники питания». Мы предлагаем Вам помощь Конструкторского отдела:

- Подбор оптимального решения, техническое обоснование при выборе компонента;
- Подбор аналогов;
- Консультации по применению компонента;
- Поставка образцов и прототипов;
- Техническая поддержка проекта;
- Защита от снятия компонента с производства.



Как с нами связаться

Телефон: 8 (812) 309 58 32 (многоканальный)

Факс: 8 (812) 320-02-42

Электронная почта: org@eplast1.ru

Адрес: 198099, г. Санкт-Петербург, ул. Калинина, дом 2, корпус 4, литера А.