

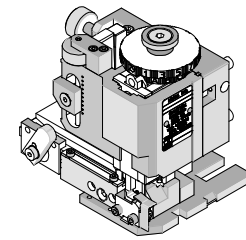

**FineAdjust
Applicator**

**Application Tooling
Specification Sheet**



Order No. 63901-0100

FEATURES

- Quick punch removal with the push of a button for fast and easy tooling change
- Applicator designed to industry standard mounting and shut height 135.80mm (5.346")
- Quick set-up time; plus the crimp height, track and feed adjustments can be set without removing the applicator from the press
- Fine adjustment allows users to achieve target with little effort by adjusting in increments of .015mm (.0006") for conductor crimp height and .063mm (.0025") for insulation height
- Independent adjustment rings allow users to quickly adjust the conductor or insulation crimp height without affecting each other
- Directly adapts to most automatic wire processing machines

SCOPE

Products: CTX64 Receptacle Terminals 0.22, 0.30, 0.35 metric and 22 AWG.

Terminal Series No.	Terminal Order No.	Wire Size		Insulation Diameter		Strip Length	
		AWG	mm ²	mm	In.	mm	In.
502306	502306-0111	-	0.22mm ² -0.35mm ²	1.10-1.65	.043-.065	4.00-4.50	.158-.177
	502306-0211						
	502306-0403	22 AWG	-				
	502306-2303						
34803	34803-0211	-	0.22mm ² -0.35mm ²	1.10-1.65	.043-.065	4.00-4.50	.158-.177
		22 AWG	-				
34863	34863-0411	-	0.22mm ² -0.35mm ²	1.10-1.65	.043-.065	4.00-4.50	.158-.177
		22 AWG	-				

DEFINITION OF TERMS

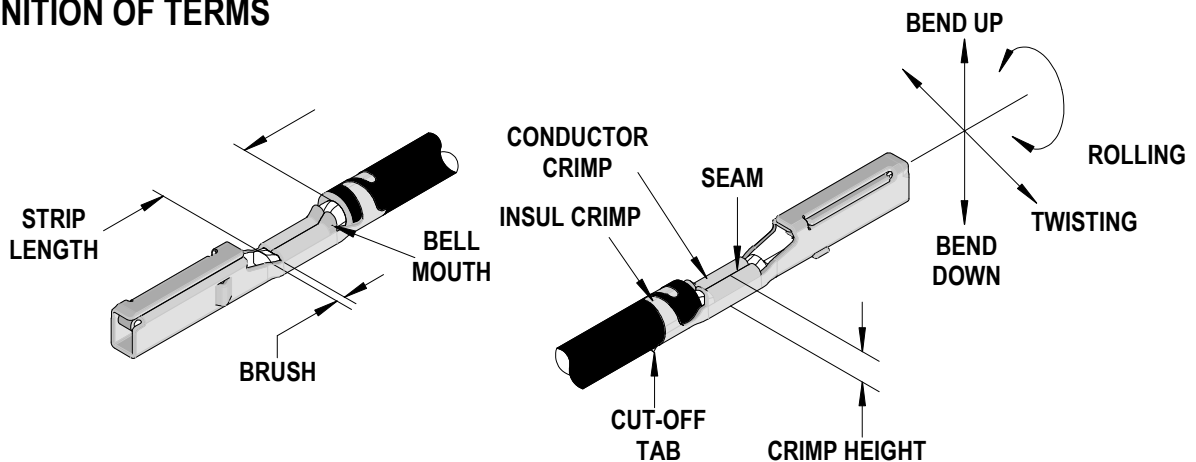

CRIMP SPECIFICATION

Terminal Series No.	Bell mouth		Cut-off Tab Maximum		* Conductor Brush	
	mm	In.	mm	In.	mm	In.
502306	0.20-0.55	.008-.022	0.30	.012	0.20-1.00	.008-.039
34803						
34863						
* Wire brush must be flush or below top of Conductor Crimp.						

Terminal Series No.	Bend up	Bend down	Twist Roll		Punch Width (Ref)				Seam Seam shall not be open and no wire allowed out of the crimping area
	Degree (Max)		Degree (Max)		Conductor		Insulation		
	mm	In	mm	In	mm	In	mm	In	
502306	1	2	4	6	1.30	.051	1.45	.057	
34803									
34863									

After crimping, the crimp profiles should measure the following:

Terminal Order No.	Wire Size		Conductor				Insulation				Pull Force Minimum N Lb.	
			Crimp Height		Crimp Width (Ref)		Crimp Height Maximum		Crimp Width Maximum			
	Wire Type	mm ² / AWG	mm	In.	mm	In.	mm	In.	mm	In.		
502306-0111	FLRY-A	0.22	0.62-0.68	.024-.027	1.30	.051	1.50	.059	1.60	.063	35	7.9
502306-0211												
34803-0211												
502306-0111	T3ZHID	0.35	0.72-0.78	.028-.031	1.30	.051	1.70	.067	1.60	.063	60	13.5
502306-0211												
502306-0403												
502306-2303												
34803-0211												
34863-0411												
502306-0111	A3	0.35	0.72-0.78	.028-.031	1.30	.051	1.95	.077	1.60	.063	60	13.5
502306-0211												
502306-0403												
502306-2303												
34803-0211												
34863-0411												
502306-0111	AVSS	0.30	0.72-0.78	.028-.031	1.30	.051	1.80	.071	1.60	.063	60	13.5
502306-0211												
34803-0211												
502306-0111	TXL	22 AWG	0.72-0.78	.028-.031	1.30	.051	1.80	.071	1.60	.063	60	13.5
502306-0211												
34803-0211												
502306-0403	TXL	22 AWG	0.69-0.75	.027-.030	1.30	.051	1.80	.071	1.60	.063	60	13.5

■ Tool Qualification Notes:

1. Pull Force should be measured with no influence from the insulation crimp.
2. The above specifications are guidelines to an optimum crimp.

PARTS LIST

FineAdjust Applicator 63901-0100				
Item	Order No	Engineering No.	Description	Quantity
Perishable Tooling				
	63901-0170	63901-0170	Tool Kit (All "Y" Items)	REF
1	63457-0041	63457-0041	Conductor Punch	1 Y
2	63455-0053	63455-0053	Conductor Anvil	1 Y
3	63454-0074	63454-0074	Insulation Punch	1 Y
4	63456-0048	63456-0048	Insulation Anvil	1 Y
5	63443-0003	63443-0003	Cut-Off Plunger	1 Y
6	63443-0012	63443-0012	Front Plunger Retainer	1 Y
Other Components				
7	11-17-0022	1739-21	Hold Down Spring	1
8	11-18-4083	60707-8	Feed Guide	1
9	11-24-1067	4996-4	Cut-off Plunger Spring	1
10	63443-0009	63443-0009	Scrap Chute	1
11	63443-0024	63443-0024	Key	1
12	63443-0090	63443-0090	Wire Stop	1
13	63443-0093	63443-0093	Shank	1
14	63443-2212	63443-2212	Coarse Spacer (12.00mm)	1
15	63443-2313	63443-2313	Fine Spacer (3.65mm)	1
16	63443-2804	63443-2804	Front Plunger Striker	1
17	63443-6109	63443-6109	Rear Cover	1
18	63443-7103	63443-7103	Terminal Hold Down	1
19	63600-1057	63600-1057	Striker Plunger Spring	1
20	63890-0032	63890-0032	Guide Height Spacer	1
21	63890-0034	63890-0034	Secondary Height Spacer	1
22	63890-0069	63890-0069	Wire Hold-Down Plunger	1
Frame				
23	63800-4901	63800-4901	Top	1
24	63801-3281	63801-3281	Base	1
25	63801-4650	63801-4650	Track	1
Hardware				
26	N/A	N/A	M3 by 6 Long SHCS	2**
27	N/A	N/A	M3 by 6 Long FHCS	1**
28	N/A	N/A	M3 by 8 Long SHCS	1**
29	N/A	N/A	M4 by 6 Long SHCS	2**
30	N/A	N/A	M4 by 12 Long BHCS	2**
31	N/A	N/A	M4 by 50 Long SHCS	2**
32	N/A	N/A	M5 by 12 Long SHCS	1**
33	N/A	N/A	#10-32 by 3/8" Long Flat Point SSS	1**
34	N/A	N/A	#10-32 Hex Jam Nut	1**
** Available from an industrial supply company such as MSC (1-800-645-7270).				

Assembly Drawing

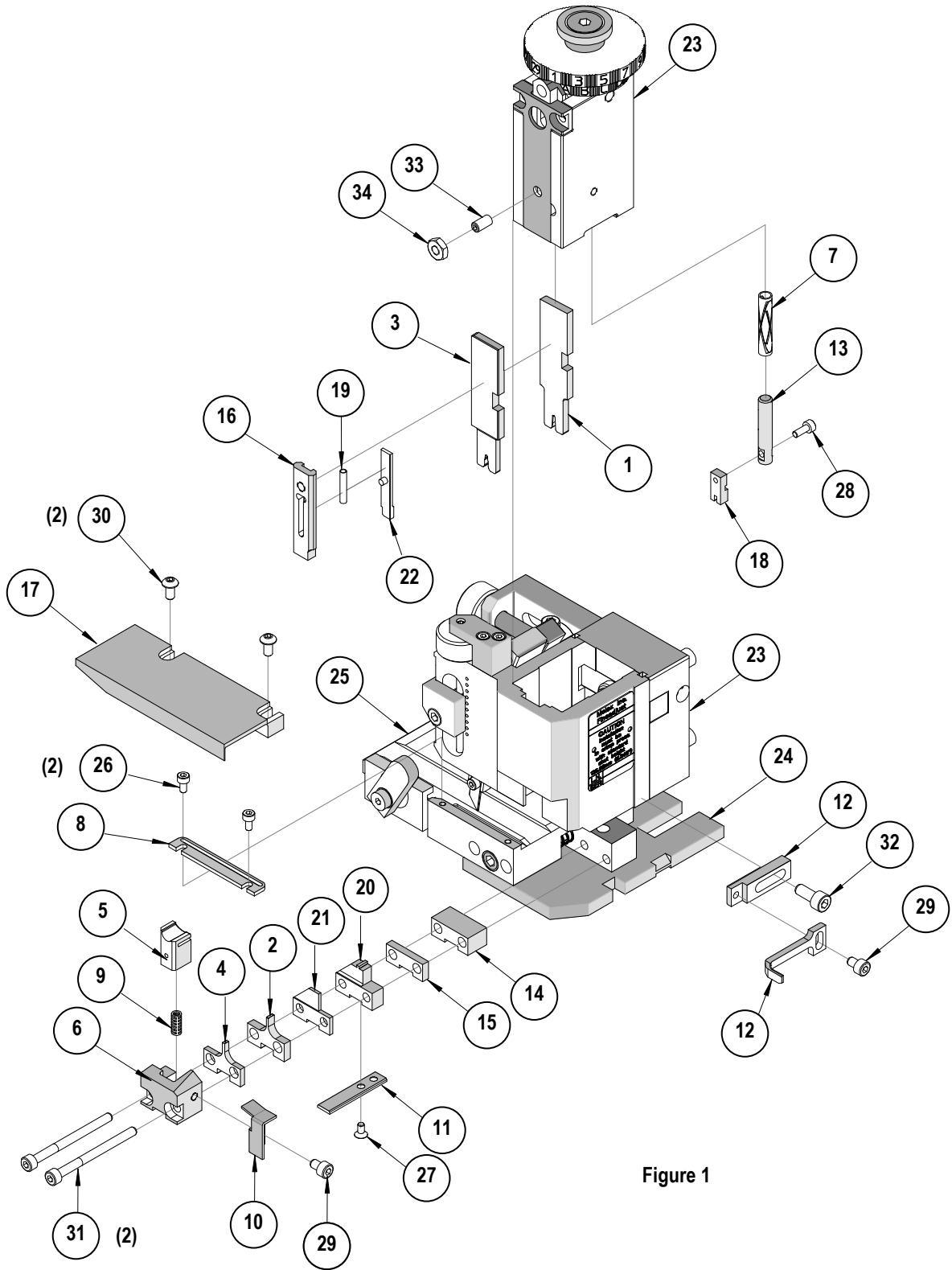

Figure 1

NOTES

1. Molex recommends an extra perishable tooling kit be maintained at your facility.
2. Verify tooling alignment by manually cycling the press and Applicator before crimping under power. Check that all screws are tight.
3. Slugs, Terminals, Dirt and Oil should be kept clear of work area.
4. Wear safety glasses at all times.
5. For recommended maintenance refer to the FineAdjust Manual.

CAUTION: This applicator should only be used in a press with a shut height of 135.80 mm (5.346"). Tooling damage could result at a lower setting.

CAUTION: To prevent injury never operate this Applicator without the guards supplied with the press or wire-processing machine in place. Reference the press or wire processing manufacturer's instruction manual.

CAUTION: Molex crimp specifications are valid only when used with Molex terminals, applicators and tooling.

Visit our Web site at <http://www.molex.com>



Компания «ЭлектроПласт» предлагает заключение долгосрочных отношений при поставках импортных электронных компонентов на взаимовыгодных условиях!

Наши преимущества:

- Оперативные поставки широкого спектра электронных компонентов отечественного и импортного производства напрямую от производителей и с крупнейших мировых складов;
- Поставка более 17-ти миллионов наименований электронных компонентов;
- Поставка сложных, дефицитных, либо снятых с производства позиций;
- Оперативные сроки поставки под заказ (от 5 рабочих дней);
- Экспресс доставка в любую точку России;
- Техническая поддержка проекта, помощь в подборе аналогов, поставка прототипов;
- Система менеджмента качества сертифицирована по Международному стандарту ISO 9001;
- Лицензия ФСБ на осуществление работ с использованием сведений, составляющих государственную тайну;
- Поставка специализированных компонентов (Xilinx, Altera, Analog Devices, Intersil, Interpoint, Microsemi, Aeroflex, Peregrine, Syfer, Eurofarad, Texas Instrument, Miteq, Cobham, E2V, MA-COM, Hittite, Mini-Circuits, General Dynamics и др.);

Помимо этого, одним из направлений компании «ЭлектроПласт» является направление «Источники питания». Мы предлагаем Вам помощь Конструкторского отдела:

- Подбор оптимального решения, техническое обоснование при выборе компонента;
- Подбор аналогов;
- Консультации по применению компонента;
- Поставка образцов и прототипов;
- Техническая поддержка проекта;
- Защита от снятия компонента с производства.



Как с нами связаться

Телефон: 8 (812) 309 58 32 (многоканальный)

Факс: 8 (812) 320-02-42

Электронная почта: org@eplast1.ru

Адрес: 198099, г. Санкт-Петербург, ул. Калинина, дом 2, корпус 4, литера А.