



This board assembly 'breaks out' the 5 x 7 pins of the eRIC RF Transceiver to a more convenient 2 x 12 x 0.1" pitch DIL pinout that matches commercial prototype breadboards. This allows the quick and easy testing and evaluation of eRIC modules for which these boards are intended.

The board is supplied with either an eRIC4 or eRIC9 module fitted together with a matching 434MHz or an 868/915 MHz antenna.

Pin	Function	Pin	Function
1	Carrier Detect	23	RF Gnd
2	Busy	22	GPIO
3	SDO	21	GPIO
4	SDI	20	GPIO
5	Host Ready	19	GPIO
6	Vcc - 3.3V	18	GPIO
7	0V Gnd	17	GPIO
8	JTag	16	GPIO
9	Reset	15	GPIO
10	GPIO	13	GPIO
11	GPIO	14	Frequency Select (eRIC9 only)
12	GPIO	GND	0V Gnd

Antenna connection is via an SMA Jack connector or alternatively the on-board eRIC UFL RF connector.

A supplied jumper optionally connects the eRIC Frequency Select Pin (14) to 0V Gnd setting the eRIC9 version module to a base operating frequency of 915MHz and restricting operation to meet FCC (USA) requirements.

Specifications

Temperature 20°C

Mechanical	Typical	Units	Notes
Size	67 x 20 x 5	mm	Excluding antenna connector
Pinout	12 x 2 DIL on 0.5" pitch		
Pin pitch	0.1	Inch	2.54mm

Schematic

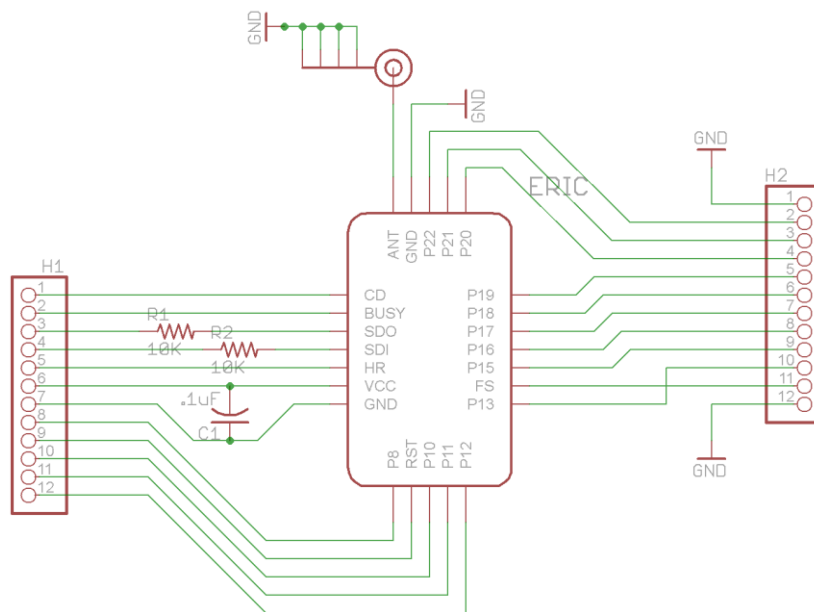

Note the 10k series resistors fitted to the SDO & SDI pins. Other eRIC pins (configured as inputs) may need to be similarly protected if connected to external 5V logic level signals.

Acknowledgements

The design is 'Open Hardware' designed and published by Rick Winscot. Details: www.quilix.com

Product Order Codes

Name	Description	Frequency	Order Code
eRIC400 Breakout Board	UK/European Version (eRIC Can Marked '4')	433MHz	eRIC4-BOB
eRIC900 Breakout Board	Europe/US Version (eRIC Can Marked '9')	868/915MHz	eRIC9-BOB
Antenna	UK & Europe	433MHz	ANTSR433
Antenna	Europe & USA	868/915MHz	ANTST900

Document History

Issue	Date	Notes/Comments
V1.0	May 2015	This version

Terms and Conditions of Use

Low Power Radio Solutions Ltd has an on-going policy to improve the performance and reliability of their products; we therefore reserve the right to make changes without notice. The information contained in this data sheet is believed to be accurate however we do not assume any responsibility for errors or any liability arising from the application or use of any product or circuit described herein. This data sheet neither states nor implies warranty of any kind, including fitness for any particular application.

easyRadio modules are a component part of an end system product and should be treated as such. Testing to fitness is the sole responsibility of the manufacturer of the device into which easyRadio products are fitted, and is expected BEFORE deployment into the field.

Any liability from defect or malfunction is limited to the replacement of product ONLY, and does not include labour or other incurred corrective expenses.

Using or continuing to use these devices hereby binds the user to these terms.



Low Power Radio Solutions Ltd.
Two Rivers Industrial Estate
Station Lane, Witney
Oxon, OX28 4BH
England

Tel: +44 (0)1993 709418
Fax: +44 (0)1993 708575
Web: <http://www.lprs.co.uk>
Email: info@lprs.co.uk
Technical: technical@lprs.co.uk



Компания «ЭлектроПласт» предлагает заключение долгосрочных отношений при поставках импортных электронных компонентов на взаимовыгодных условиях!

Наши преимущества:

- Оперативные поставки широкого спектра электронных компонентов отечественного и импортного производства напрямую от производителей и с крупнейших мировых складов;
- Поставка более 17-ти миллионов наименований электронных компонентов;
- Поставка сложных, дефицитных, либо снятых с производства позиций;
- Оперативные сроки поставки под заказ (от 5 рабочих дней);
- Экспресс доставка в любую точку России;
- Техническая поддержка проекта, помощь в подборе аналогов, поставка прототипов;
- Система менеджмента качества сертифицирована по Международному стандарту ISO 9001;
- Лицензия ФСБ на осуществление работ с использованием сведений, составляющих государственную тайну;
- Поставка специализированных компонентов (Xilinx, Altera, Analog Devices, Intersil, Interpoint, Microsemi, Aeroflex, Peregrine, Syfer, Eurofarad, Texas Instrument, Miteq, Cobham, E2V, MA-COM, Hittite, Mini-Circuits, General Dynamics и др.);

Помимо этого, одним из направлений компании «ЭлектроПласт» является направление «Источники питания». Мы предлагаем Вам помощь Конструкторского отдела:

- Подбор оптимального решения, техническое обоснование при выборе компонента;
- Подбор аналогов;
- Консультации по применению компонента;
- Поставка образцов и прототипов;
- Техническая поддержка проекта;
- Защита от снятия компонента с производства.



Как с нами связаться

Телефон: 8 (812) 309 58 32 (многоканальный)

Факс: 8 (812) 320-02-42

Электронная почта: org@eplast1.ru

Адрес: 198099, г. Санкт-Петербург, ул. Калинина, дом 2, корпус 4, литера А.