

THIS DRAWING IS UNPUBLISHED. RELEASED FOR PUBLICATION 20
 © COPYRIGHT 20 BY ALL RIGHTS RESERVED.

LOC		DIST		REVISIONS			
P	LTR	DESCRIPTION	DATE	DWN	APVD		
	E2	REVISED PER ECO-11-004917	12MAR2011	RK	HMR		

- 1 MATERIALS AND FINISH
 HOUSING: PA 6-6, UL 94-V0, COLOR: GREEN.
 CLAMP: BRASS, NICKEL PLATED.
 CONTACT SPRING : PHOSPHOR BRONZE, TIN PLATED.
 CLAMPING SCREW: M3, BRASS, NICKEL PLATED.
- 2. WIRE SIZE RANGE: 12 - 30 AWG
- 3 NOT CUMULATIVE TOLERANCE.
- 4. INK MARKING, COLOR: BLACK.
- 5 WIRE ENTRY CLOSED
- 6 PRELIMINARY

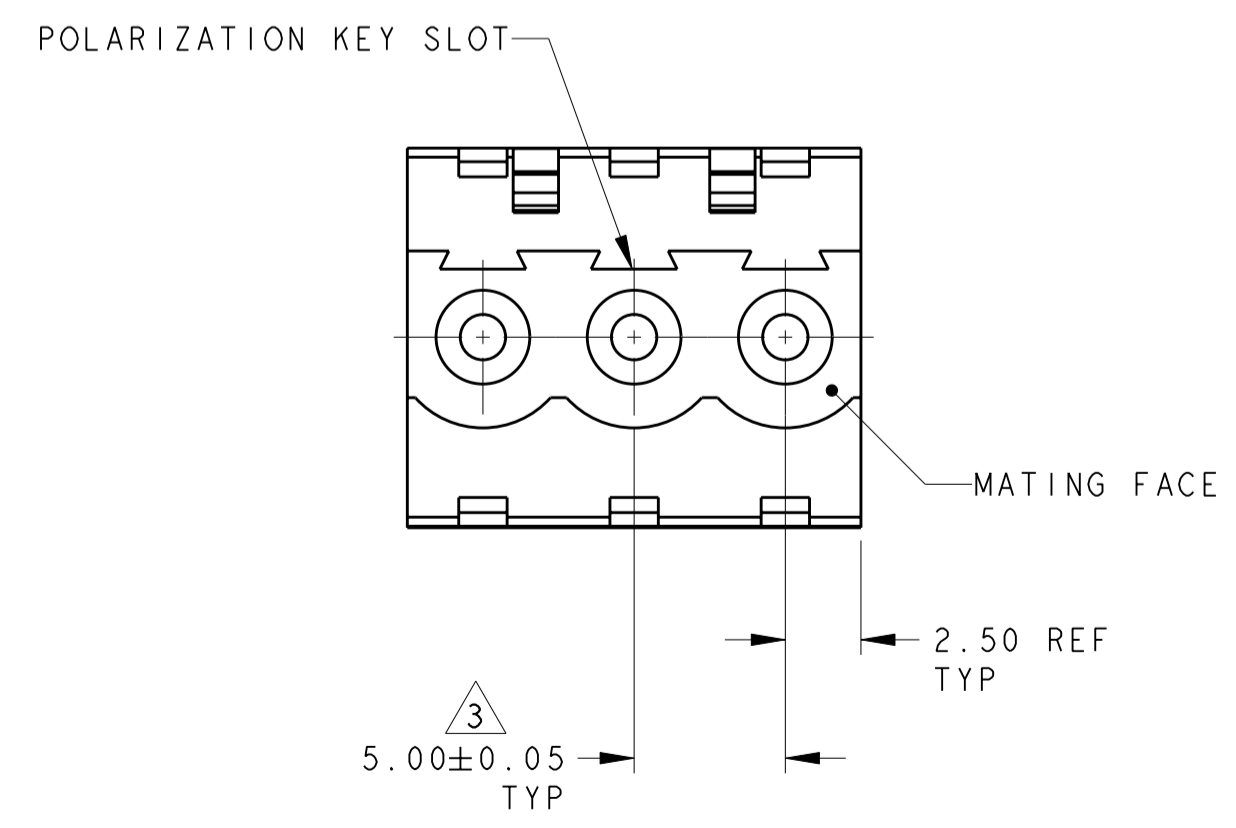
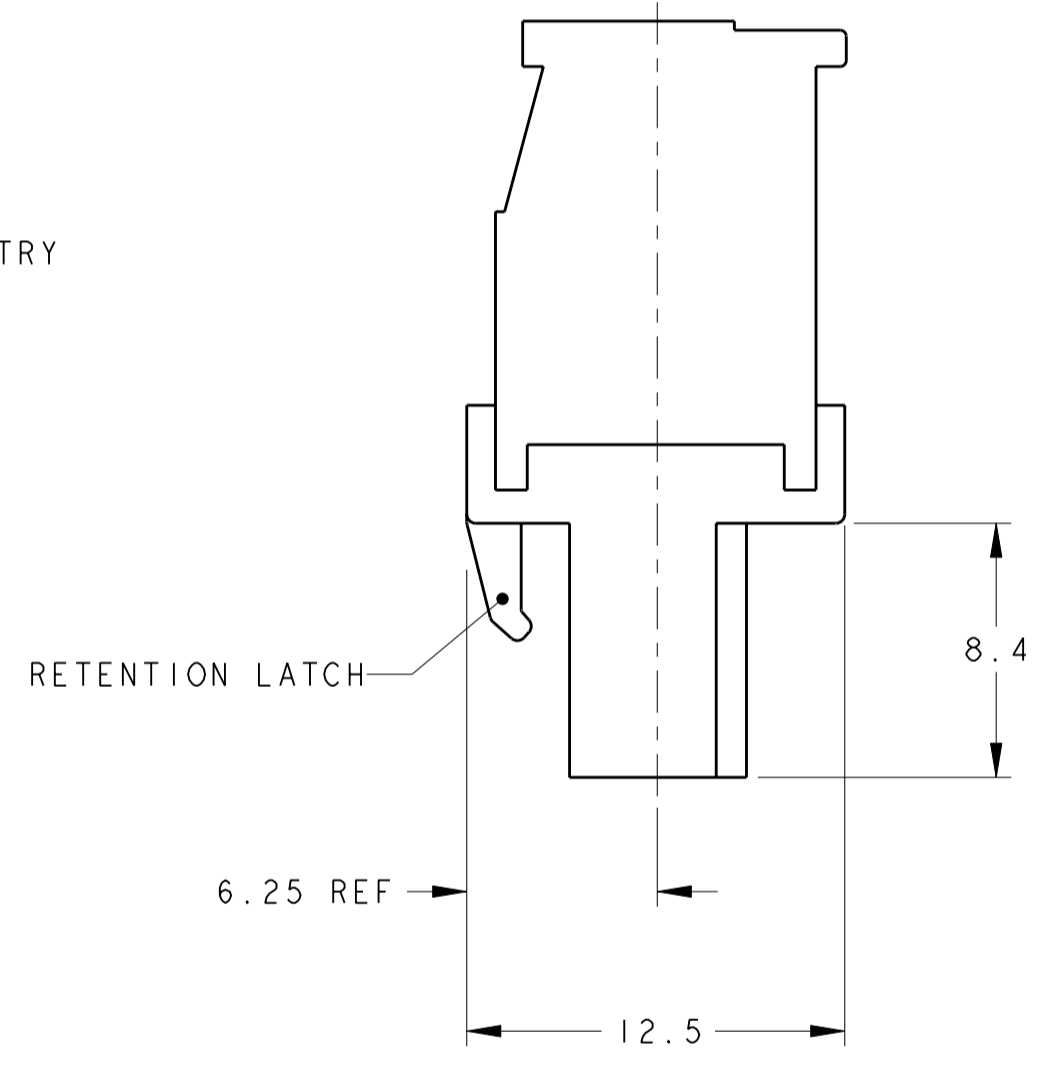
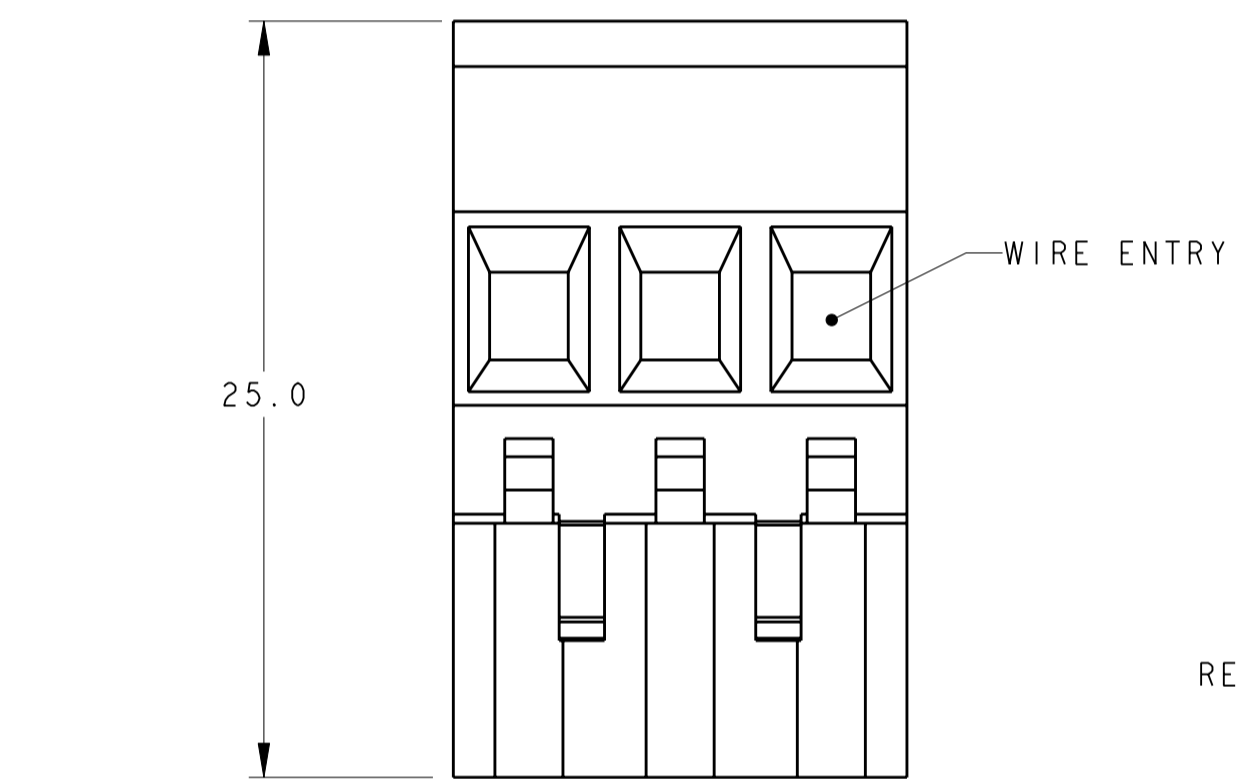
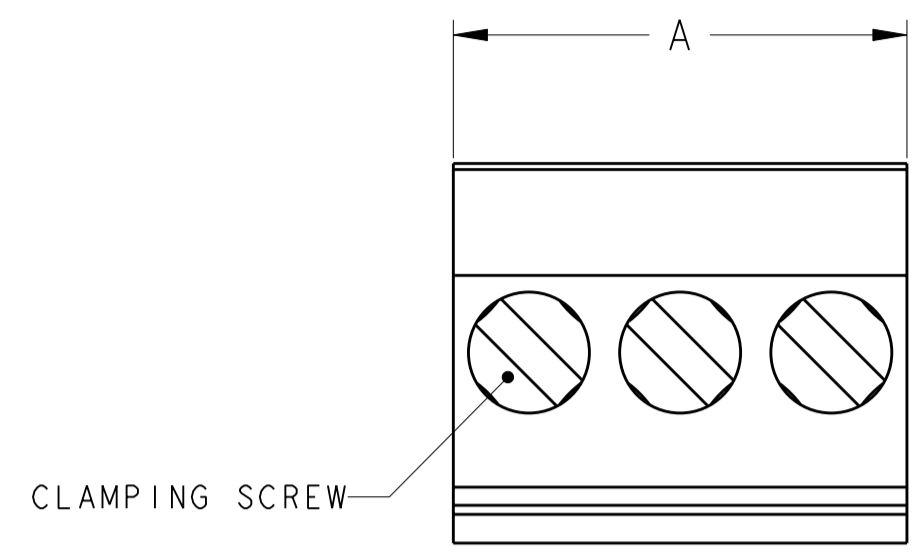

6	TIN PLATED	SEE SHEET 3	70.0	14	3-284046-5
6	TIN PLATED	SEE SHEET 3	50.0	10	3-284046-4
6	TIN PLATED	SEE SHEET 3	90.0	18	3-284046-3
6	TIN PLATED	SEE SHEET 3	80.0	16	3-284046-2
	TIN PLATED	SEE SHEET 2	15.0	3	3-284046-1
		SEE SHEET 2	10.0	2	3-284046-0
	0.00076[.000030]	SEE SHEET 2	25.0	5	2-284046-9
	SELECT GOLD	-	25.0	5	2-284046-8
		SEE SHEET 2	65.0	13	2-284046-7
		SEE SHEET 2	40.0	8	2-284046-6
		-	125.0	25	2-284046-5
		-	120.0	24	2-284046-4
		-	115.0	23	2-284046-3
		-	110.0	22	2-284046-2
		-	150.0	21	2-284046-1
		-	100.0	20	2-284046-0
		-	95.0	19	1-284046-9
		-	90.0	18	1-284046-8
		-	85.0	17	1-284046-7
		-	80.0	16	1-284046-6
		-	75.0	15	1-284046-5
		-	70.0	14	1-284046-4
		-	65.0	13	1-284046-3
		-	60.0	12	1-284046-2
		-	55.0	11	1-284046-1
		-	50.0	10	1-284046-0
		-	45.0	9	284046-9
		-	40.0	8	284046-8
		-	35.0	7	284046-7
		-	30.0	6	284046-6
		-	25.0	5	284046-5
		-	20.0	4	284046-4
		-	15.0	3	284046-3
		-	10.0	2	284046-2

CONTACT FINISH	MARKING	A	NO OF POSN	PART NUMBER
----------------	---------	---	------------	-------------

THIS DRAWING IS A CONTROLLED DOCUMENT.

DWN S.WELDON 05FEB2003
 CHK C.RICHARD 05FEB2003
 APVD C.RICHARD 05FEB2003

STE TE Connectivity

NAME: TERMINAL BLOCK, VERTICAL PLUG, STACKING, RIGHT HAND, 5.00mm PITCH

SIZE: A2 CAGE CODE: 00779 DRAWING NO: C-284046 RESTRICTED TO: -

MATERIAL: TOLERANCES UNLESS OTHERWISE SPECIFIED: 0 PLC ±.3, 1 PLC ±.3, 2 PLC ±.25, 3 PLC ±.25, 4 PLC ±.25, ANGLES ±2, FINISH

CUSTOMER DRAWING SCALE: 4:1 SHEET 1 OF 3 REV E2

THIS DRAWING IS UNPUBLISHED. RELEASED FOR PUBLICATION 20
 © COPYRIGHT 20 BY ALL RIGHTS RESERVED.

LOC	DIST	REVISIONS			
P	LTR	DESCRIPTION	DATE	DWN	APVD
FT	0	-	SEE SHEET 1	-	-

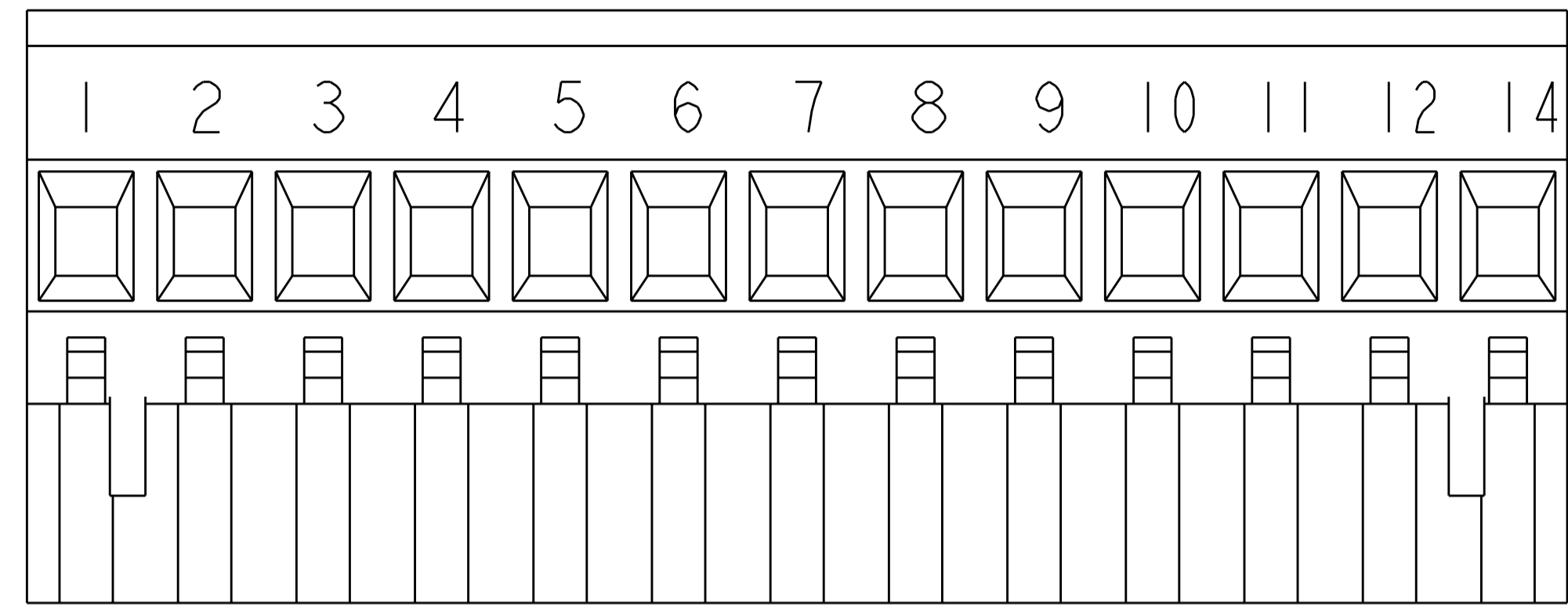

2-284046-7 AS SHOWN

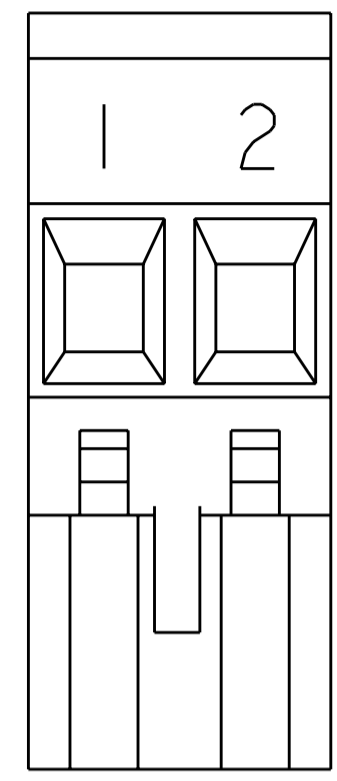

3-284046-0 AS SHOWN

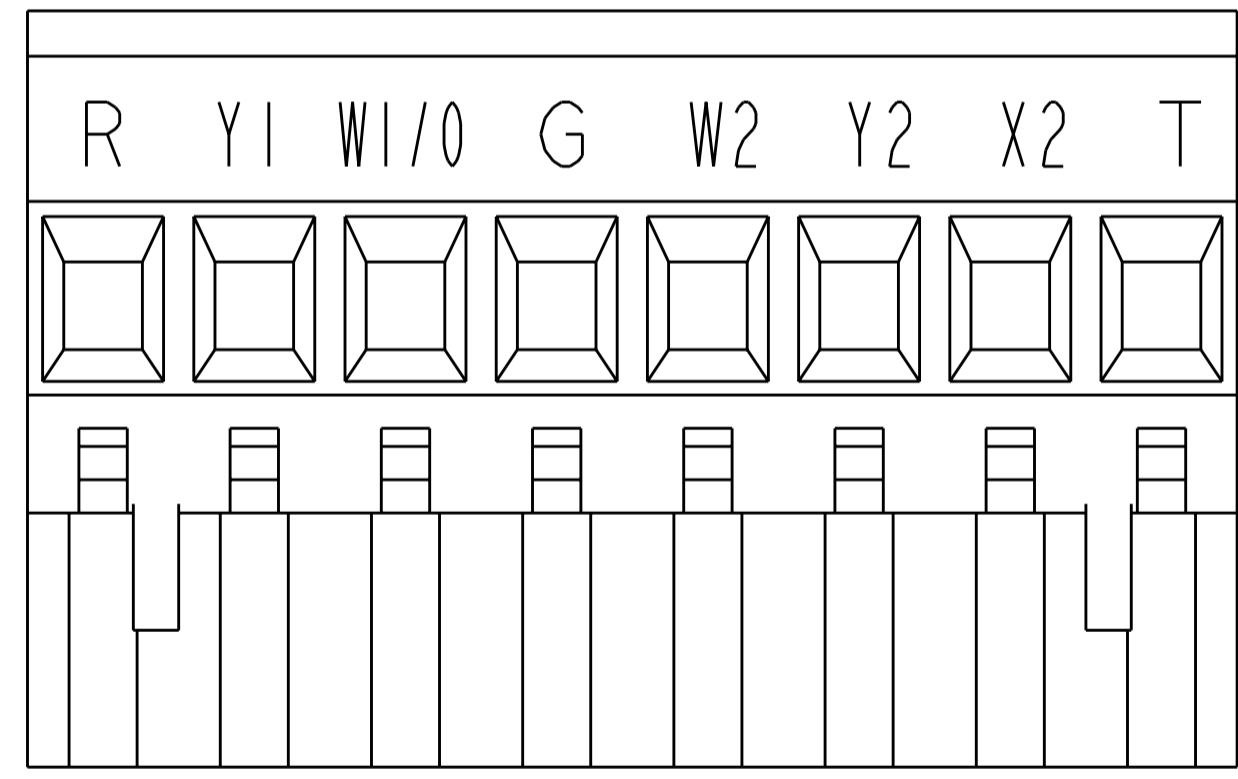

2-284046-6 AS SHOWN

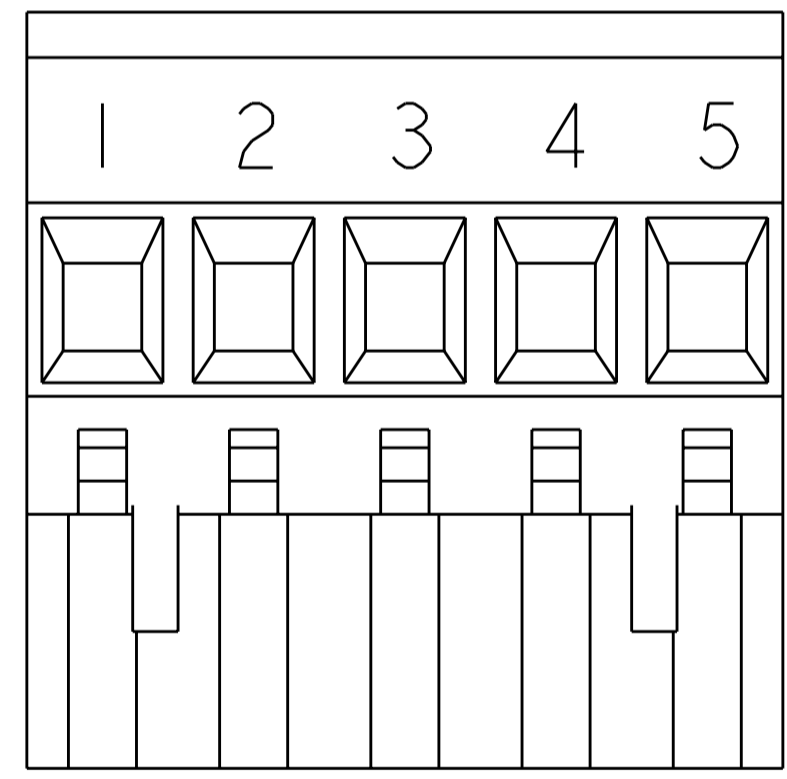

2-284046-9 AS SHOWN

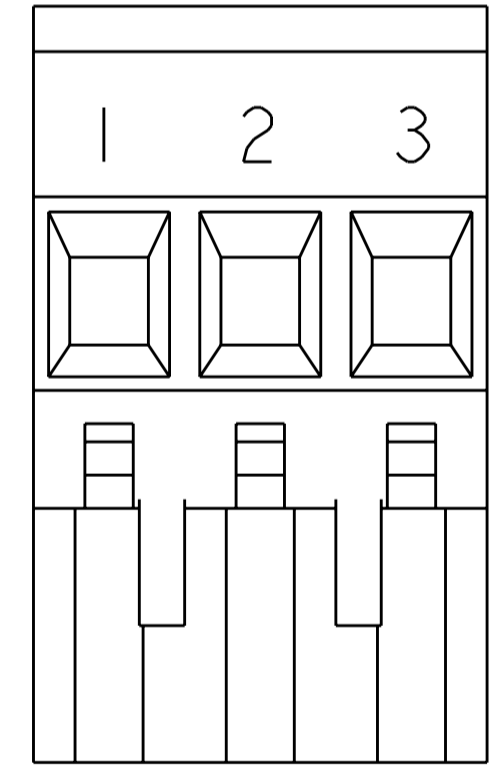

3-284046-1 AS SHOWN

THIS DRAWING IS A CONTROLLED DOCUMENT.		DWN S. WELDON 05FEB2003	 TE Connectivity	
DIMENSIONS: mm		CHK C. RICHARD 05FEB2003		
TOLERANCES UNLESS OTHERWISE SPECIFIED:		APVD C. RICHARD 05FEB2003	NAME TERMINAL BLOCK, VERTICAL PLUG, STACKING, RIGHT HAND, 5.00mm PITCH	
0 PLC ±- 1 PLC ±.3 2 PLC ±.25 3 PLC ±- 4 PLC ±- ANGLES ±2 FINISH		PRODUCT SPEC -	SIZE A200779	DRAWING NO C-284046
MATERIAL -		APPLICATION SPEC -	RESTRICTED TO -	SCALE 4:1
		WEIGHT -	SHEET 2 OF 3	
		CUSTOMER DRAWING		REV E2

THIS DRAWING IS UNPUBLISHED. RELEASED FOR PUBLICATION 20
 © COPYRIGHT 20 BY - ALL RIGHTS RESERVED.

LOC	DIST	REVISIONS			
P	LTR	DESCRIPTION	DATE	DWN	APVD
FT	0	-	SEE SHEET 1	-	-

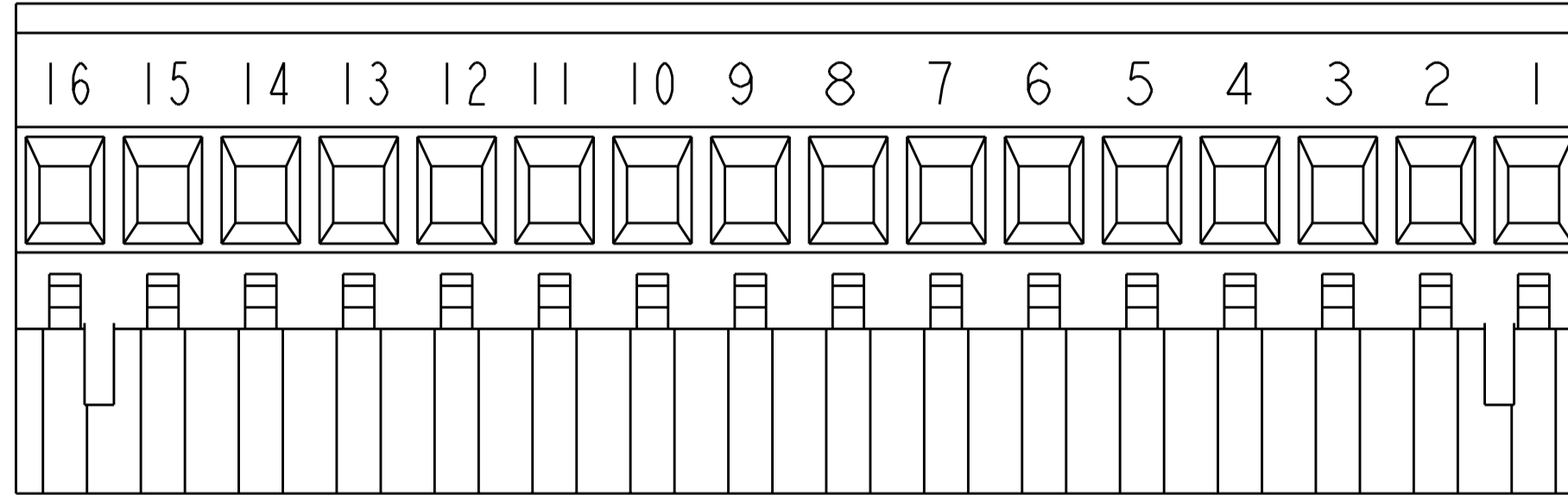

3-284046-2 AS SHOWN $\triangle 5$

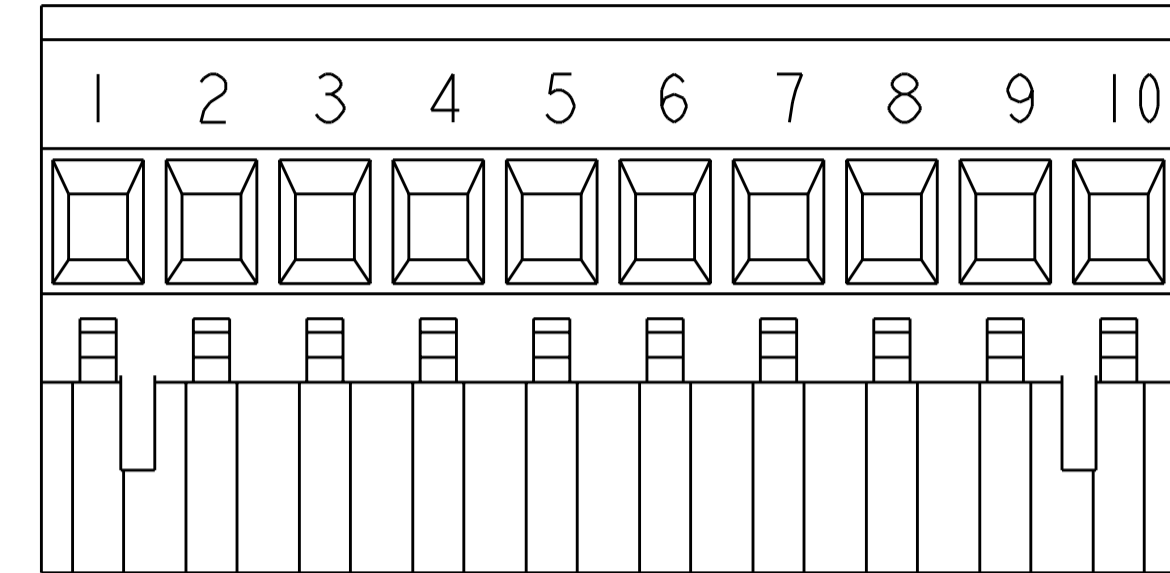

3-284046-4 AS SHOWN

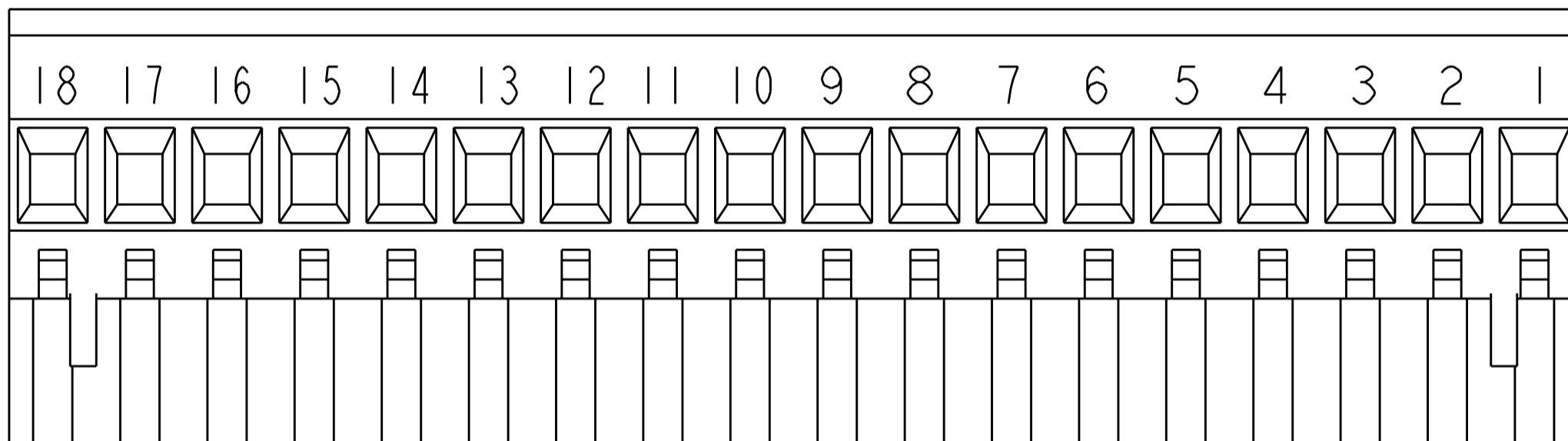

3-284046-3 AS SHOWN $\triangle 5$

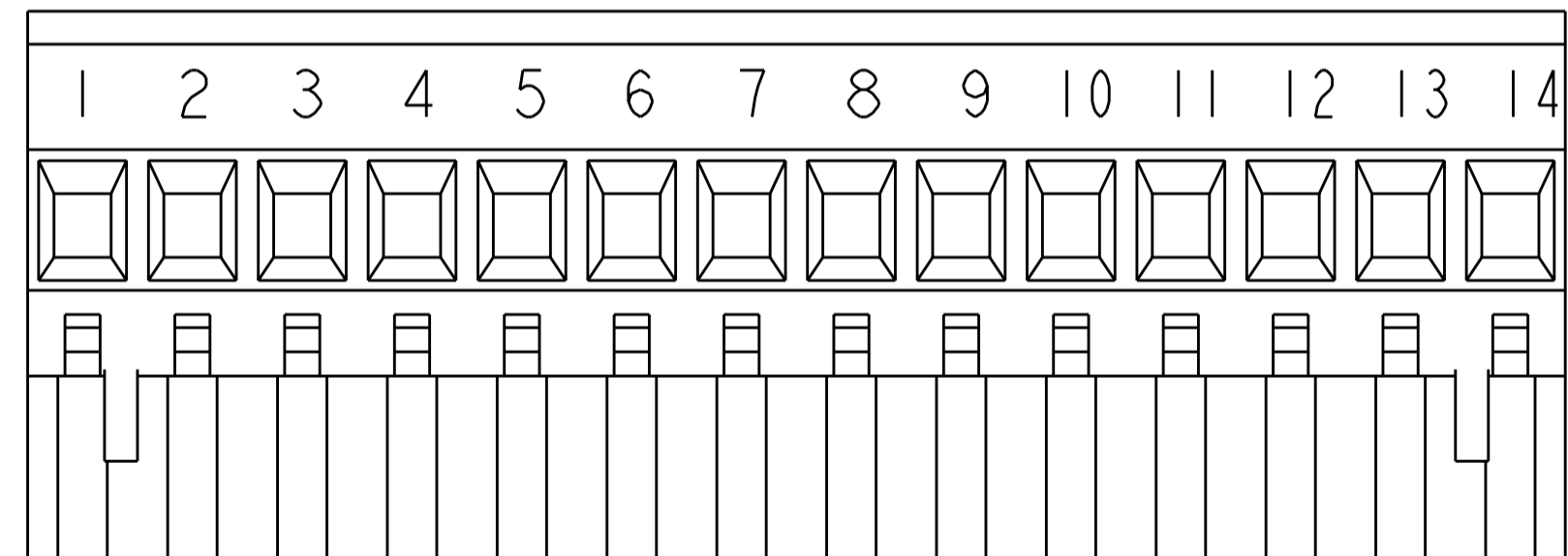

3-284046-5 AS SHOWN

THIS DRAWING IS A CONTROLLED DOCUMENT.		DWN S.WELDON 05FEB2003	 TE Connectivity	
DIMENSIONS: mm		CHK C.RICHARD 05FEB2003		
TOLERANCES UNLESS OTHERWISE SPECIFIED:		APVD C.RICHARD 05FEB2003	NAME TERMINAL BLOCK, VERTICAL PLUG, STACKING, RIGHT HAND, 5.00mm PITCH	
0 PLC ±- 1 PLC ±.3 2 PLC ±.25 3 PLC ±- 4 PLC ±- ANGLES ±2 FINISH		PRODUCT SPEC -	SIZE A2	CAGE CODE 00779
MATERIAL -		APPLICATION SPEC -	DRAWING NO. C-284046	RESTRICTED TO -
		WEIGHT -	SCALE 3:1	SHEET 3 OF 3 REV E2
		CUSTOMER DRAWING		



Компания «ЭлектроПласт» предлагает заключение долгосрочных отношений при поставках импортных электронных компонентов на взаимовыгодных условиях!

Наши преимущества:

- Оперативные поставки широкого спектра электронных компонентов отечественного и импортного производства напрямую от производителей и с крупнейших мировых складов;
- Поставка более 17-ти миллионов наименований электронных компонентов;
- Поставка сложных, дефицитных, либо снятых с производства позиций;
- Оперативные сроки поставки под заказ (от 5 рабочих дней);
- Экспресс доставка в любую точку России;
- Техническая поддержка проекта, помощь в подборе аналогов, поставка прототипов;
- Система менеджмента качества сертифицирована по Международному стандарту ISO 9001;
- Лицензия ФСБ на осуществление работ с использованием сведений, составляющих государственную тайну;
- Поставка специализированных компонентов (Xilinx, Altera, Analog Devices, Intersil, Interpoint, Microsemi, Aeroflex, Peregrine, Syfer, Eurofarad, Texas Instrument, Miteq, Cobham, E2V, MA-COM, Hittite, Mini-Circuits, General Dynamics и др.);

Помимо этого, одним из направлений компании «ЭлектроПласт» является направление «Источники питания». Мы предлагаем Вам помощь Конструкторского отдела:

- Подбор оптимального решения, техническое обоснование при выборе компонента;
- Подбор аналогов;
- Консультации по применению компонента;
- Поставка образцов и прототипов;
- Техническая поддержка проекта;
- Защита от снятия компонента с производства.



Как с нами связаться

Телефон: 8 (812) 309 58 32 (многоканальный)

Факс: 8 (812) 320-02-42

Электронная почта: org@eplast1.ru

Адрес: 198099, г. Санкт-Петербург, ул. Калинина, дом 2, корпус 4, литера А.