

4 x 48 W MOSFET quad bridge power amplifier

Datasheet - production data

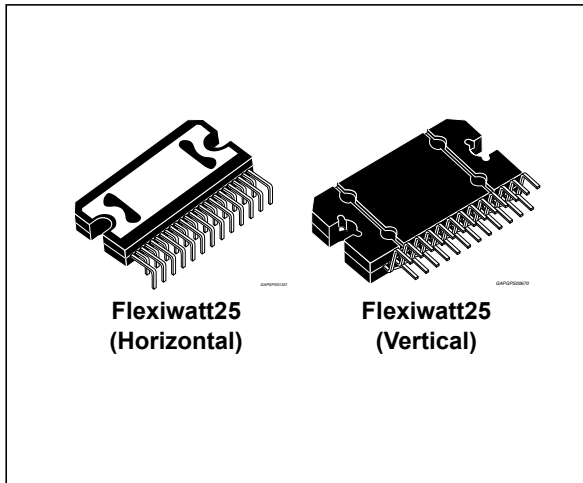

Features

- Multipower BCD technology
- High output power capability:
 - 4 x 48 W/4 Ω max.
 - 4 x 28 W/4 Ω @ 14.4 V, 1 kHz, 10%
 - 4 x 72 W/2 Ω max.
- MOSFET output power stage
- Excellent 2 Ω driving capability
- Hi-Fi class distortion
- Low output noise
- Standby function
- Mute function

- Automute at min. supply voltage detection
- Low external component count:
 - Internally fixed gain (26 dB)
 - No external compensation
 - No bootstrap capacitors
- Output DC offset detector
- Protections:
 - Output short circuit to GND, to V_S , across the load
 - Very inductive loads
 - Overrating chip temperature with soft thermal limiter
 - Load dump voltage
 - Fortuitous open GND
 - Reversed battery
 - ESD

Description

The TDA7851F is a breakthrough MOSFET technology class AB audio power amplifier, designed for high-power car radio.

The fully complementary P-Channel/N-Channel output structure allows a rail-to-rail output voltage swing. This, combined with high output current and minimized saturation losses, sets new power references in the car-radio field, with unparalleled distortion performance.

Table 1. Device summary

Order code	Package	Packing
TDA7851F	Flexiwatt25 (vertical)	Tube
TDA7851FH-QIX	Flexiwatt25 (horizontal)	Tube

Contents

- 1 Block diagram and application circuit 5**
 - 1.1 Block diagram 5
 - 1.2 Application circuit 5

- 2 Pin description 6**
 - 2.1 Pin connection 6
 - 2.2 Thermal data 6

- 3 Electrical specifications 7**
 - 3.1 Absolute maximum ratings 7
 - 3.2 Electrical characteristics 7
 - 3.3 Electrical characteristics curves 9

- 4 Application hints 12**
 - 4.1 SVR 12
 - 4.2 Input stage 12
 - 4.3 Standby and muting 12
 - 4.4 Heatsink definition 12

- 5 Package information 13**
 - 5.1 Flexiwatt 25 (vertical) package information 13
 - 5.2 Flexiwatt 25 (horizontal) package information 15

- 6 Revision history 17**

List of tables

Table 1.	Device summary	1
Table 2.	Thermal data	6
Table 3.	Absolute maximum ratings	7
Table 4.	Electrical characteristics	7
Table 5.	Flexiwatt 25 (vertical) package mechanical data	13
Table 6.	Flexiwatt 25 (horizontal) package mechanical data	15
Table 7.	Document revision history	17

List of figures

Figure 1.	Block diagram	5
Figure 2.	Application circuit	5
Figure 3.	Pin connection (top view)	6
Figure 4.	Quiescent current vs. supply voltage	9
Figure 5.	Output power vs. supply voltage ($R_L = 4 \Omega$)	9
Figure 6.	Output power vs. supply voltage ($R_L = 2 \Omega$)	9
Figure 7.	Distortion vs. output power ($R_L = 4 \Omega$)	9
Figure 8.	Distortion vs. output power ($R_L = 2 \Omega$)	9
Figure 9.	Distortion vs. frequency ($R_L = 4 \Omega$)	9
Figure 10.	Distortion vs. frequency ($R_L = 2 \Omega$)	10
Figure 11.	Crosstalk vs. frequency.	10
Figure 12.	Supply voltage rejection vs. frequency	10
Figure 13.	Output attenuation vs. supply voltage.	10
Figure 14.	Power dissipation and efficiency vs. output power ($R_L = 4 \Omega$, SINE)	10
Figure 15.	Power dissipation and efficiency vs. output power ($R_L = 2 \Omega$, SINE)	10
Figure 16.	Power dissipation vs. output power ($R_L = 4 \Omega$, audio program simulation).	11
Figure 17.	Power dissipation vs. output power ($R_L = 2 \Omega$, audio program simulation).	11
Figure 18.	ITU R-ARM frequency response, weighting filter for transient pop.	11
Figure 19.	Flexiwatt 25 (vertical) package outline	13
Figure 20.	Flexiwatt 25 (horizontal) package outline	15

1 Block diagram and application circuit

1.1 Block diagram

Figure 1. Block diagram

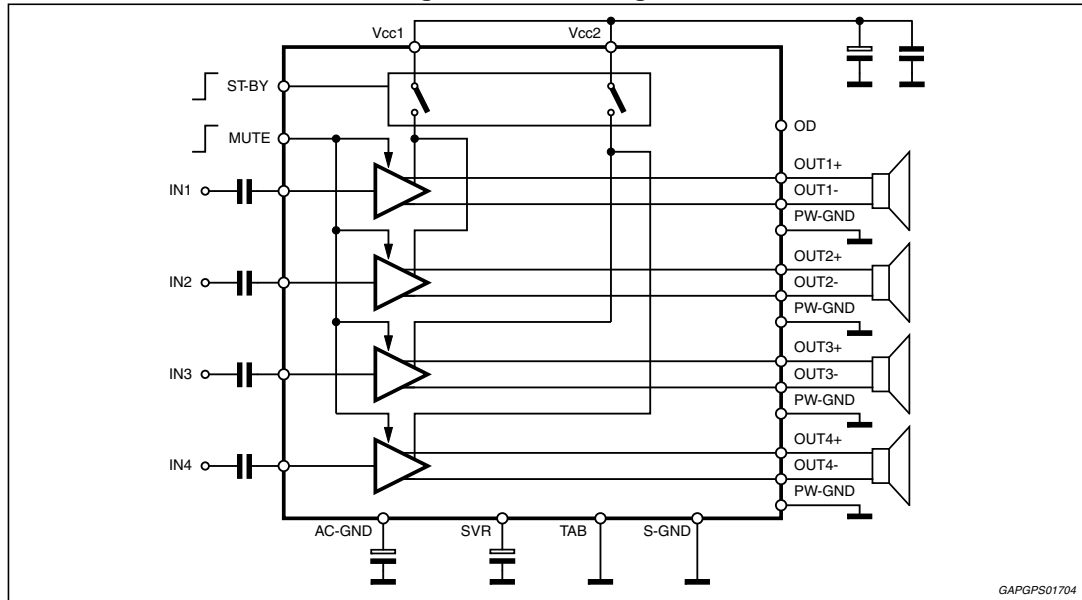

1.2 Application circuit

Figure 2. Application circuit

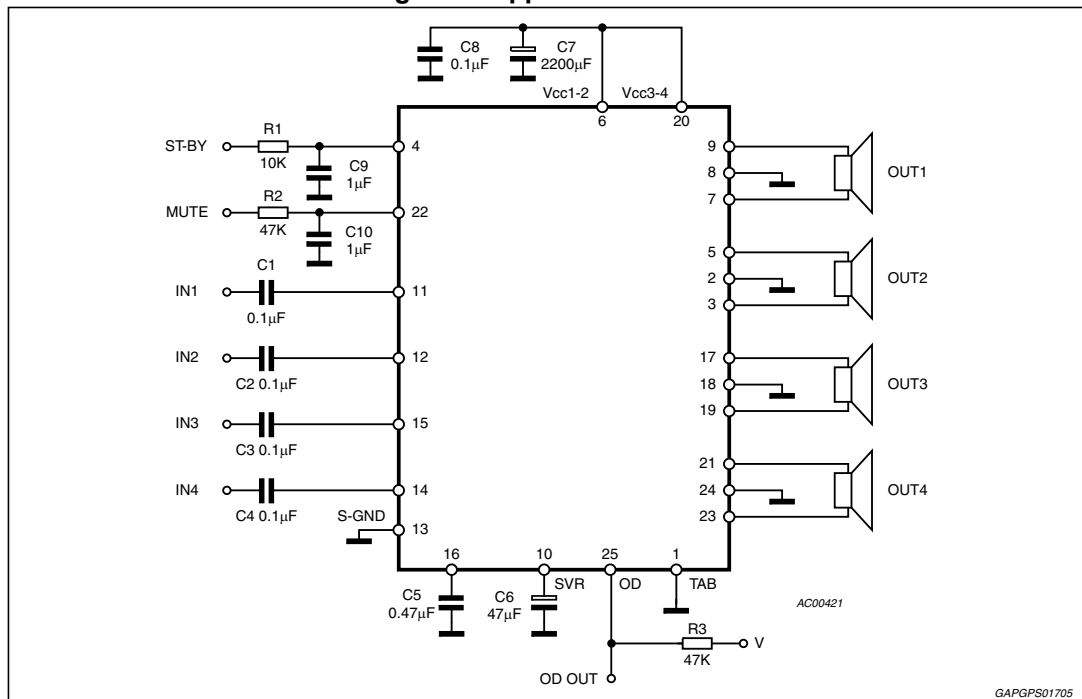

2 Pin description

2.1 Pin connection

Figure 3. Pin connection (top view)

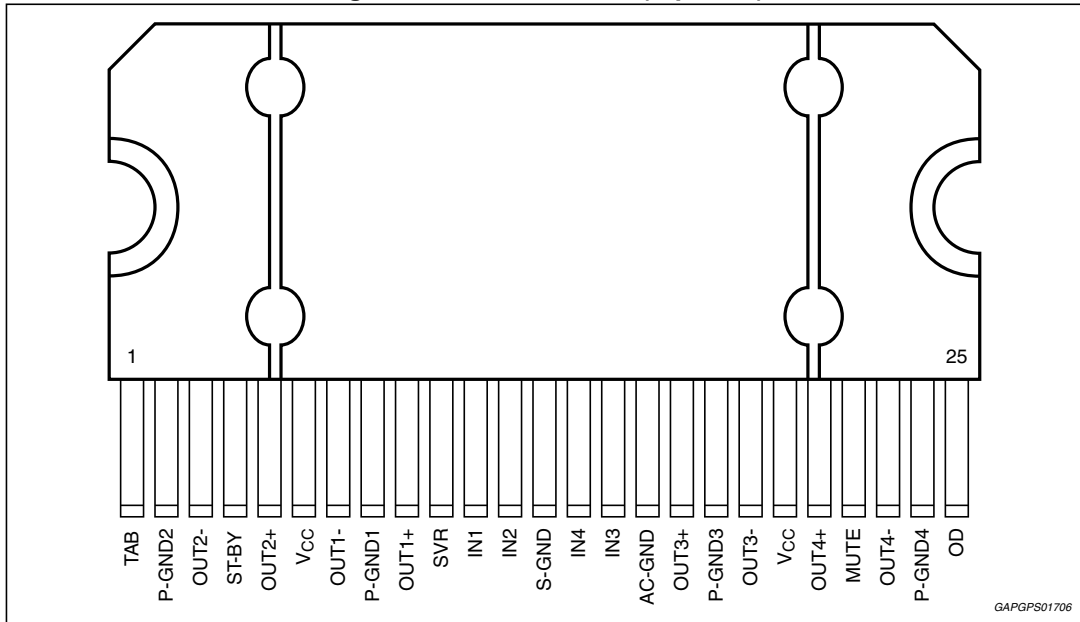

2.2 Thermal data

Table 2. Thermal data

Symbol	Parameter	Value	Unit
$R_{th\ j-case}$	Thermal resistance junction-to-case	max 1	°C/W

3 Electrical specifications

3.1 Absolute maximum ratings

Table 3. Absolute maximum ratings

Symbol	Parameter	Value	Unit
V_S	Operating supply voltage	18	V
$V_{S(DC)}$	DC supply voltage	28	V
$V_{S(pk)}$	Peak supply voltage (for $t = 50$ ms)	50	V
I_O	Output peak current Non repetitive ($t = 100$ μ s)	10	A
	Repetitive (duty cycle 10% at $f = 10$ Hz)	9	A
P_{tot}	Power dissipation $T_{case} = 70$ °C	85	W
T_j	Junction temperature	150	°C
T_{stg}	Storage temperature	-55 to 150	°C

3.2 Electrical characteristics

Refer to the test and application diagram, $V_S = 14.4$ V; $R_L = 4$ Ω ; $R_g = 600$ Ω ; $f = 1$ kHz;
 $T_{amb} = 25$ °C; unless otherwise specified.

Table 4. Electrical characteristics

Symbol	Parameter	Test condition	Min.	Typ.	Max.	Unit
V_S	Supply voltage range	-	8	-	18	V
I_{q1}	Quiescent current	$R_L = \infty$	100	150	300	mA
V_{OS}	Output offset voltage	Play mode / Mute mode	-60	-	+60	mV
dV_{OS}	During mute ON/OFF output offset voltage	ITU R-ARM weighted see Figure 18	-10	-	+10	mV
	During standby ON/OFF output offset voltage		-10	-	+10	mV
G_V	Voltage gain	-	25	26	27	dB
dG_V	Channel gain unbalance	-			± 1	dB
P_O	Output power	$V_S = 14.4$ V; THD = 10%	25	28	-	W
		$V_S = 14.4$ V; THD = 1%		22		W
		$V_S = 14.4$ V; THD = 10%, 2 Ω	-	48	-	W
		$V_S = 14.4$ V; THD = 1%, 2 Ω		38		W
$P_{Omax.}$	Max. output power ⁽¹⁾	$V_S = 14.4$ V; $R_L = 4$ Ω $V_S = 14.4$ V; $R_L = 2$ Ω ; $V_S = 15.2$ V; $R_L = 4$ Ω (square wave input (2 Vrms))	-	45 75 48	-	W

Table 4. Electrical characteristics (continued)

Symbol	Parameter	Test condition	Min.	Typ.	Max.	Unit
THD	Distortion	$P_O = 4\text{ W}$	-	0.01	0.05	%
e_{No}	Output noise	"A" Weighted $Bw = 20\text{ Hz to }20\text{ kHz}$	-	35 50	100	μV μV
SVR	Supply voltage rejection	$f = 100\text{ Hz}; V_r = 1\text{ Vrms}$	50	70	-	dB
f_{ch}	High cut-off frequency	$P_O = 0.5\text{ W}$	100	300	-	kHz
R_i	Input Impedance	-	70	100	130	k Ω
C_T	Cross talk	$f = 1\text{ kHz } P_O = 4\text{ W}$ $f = 10\text{ kHz } P_O = 4\text{ W}$	60	70 60	- -	dB dB
I_{SB}	Standby current consumption	$V_{St-By} = 1.2\text{ V}$	-	-	20	μA
		$V_{St-By} = 0$	-	-	10	μA
I_{pin5}	Standby pin current	$V_{St-By} = 1.2\text{ V to }2.6\text{ V}$	-	-	± 1	μA
$V_{SB\ out}$	Standby out threshold voltage	(Amp: ON)	2.6	-	-	V
$V_{SB\ in}$	Standby in threshold voltage	(Amp: OFF)	-	-	1.2	V
A_M	Mute attenuation	$P_{Oref} = 4\text{ W}$	80	90	-	dB
$V_{M\ out}$	Mute out threshold voltage	(Amp: Play)	2.6	-	-	V
$V_{M\ in}$	Mute in threshold voltage	(Amp: Mute)	-	-	1.2	V
$V_{AM\ in}$	V_S automute threshold	(Amp: Mute) Att. $\geq 80\text{ dB}; P_{Oref} = 4\text{ W}$	6.7	7	-	V
		(Amp: Play) Att. $< 0.1\text{ dB}; P_O = 0.5\text{ W}$	-	7.5	8	V
I_{pin23}	Muting pin current	$V_{MUTE} = 1.2\text{ V}$ (Sourced current)	7	12	18	μA
		$V_{MUTE} = 2.6\text{ V}$	-5	-	18	μA
Offset detector						
V_{OFF}	Detected diff. output offset	$V_{ST-BY} = 5\text{ V}$	± 1	± 2	± 3	V
V_{OFF_SAT}	Off detector sat voltage	$V_o > \pm 3\text{ V}, I_{off\ Det} = 1\text{ mA}$ $0\text{ V} < V_{off\ Det} < 18\text{ V}$	-	0.2	0.4	V
V_{OFF_LK}	Off detector leakage current	$V_o < \pm 1\text{ V}$	-	0	15	μA

1. Saturated square wave output

3.3 Electrical characteristics curves

Figure 4. Quiescent current vs. supply voltage

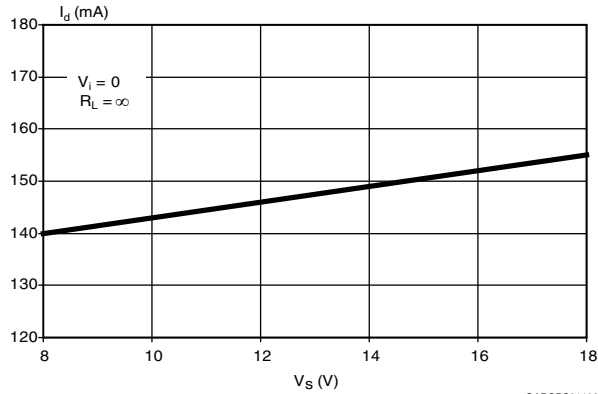

Figure 5. Output power vs. supply voltage ($R_L = 4 \Omega$)

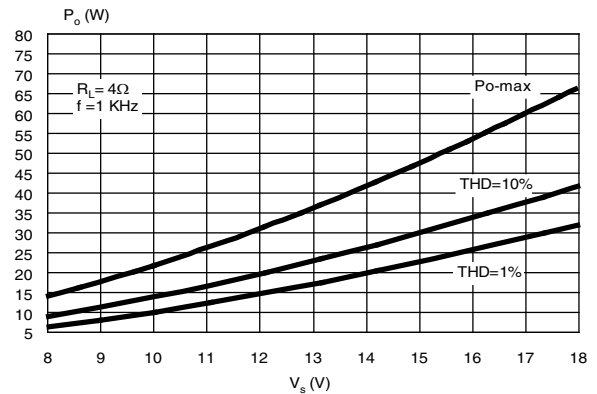

Figure 6. Output power vs. supply voltage ($R_L = 2 \Omega$)

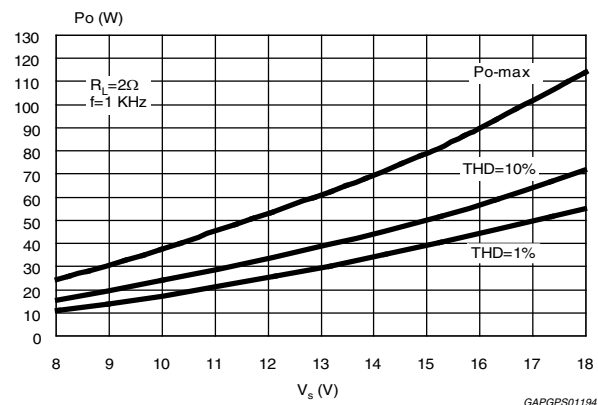

Figure 7. Distortion vs. output power ($R_L = 4 \Omega$)

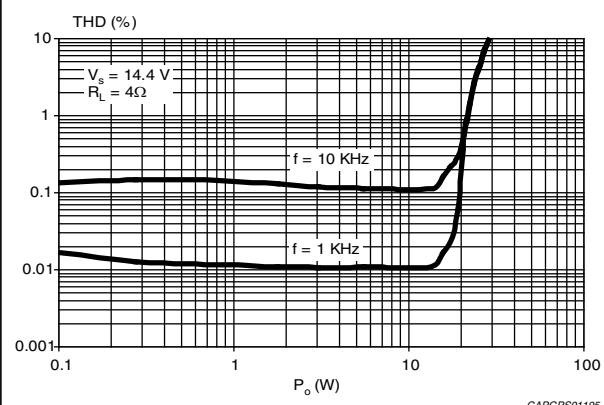

Figure 8. Distortion vs. output power ($R_L = 2 \Omega$)

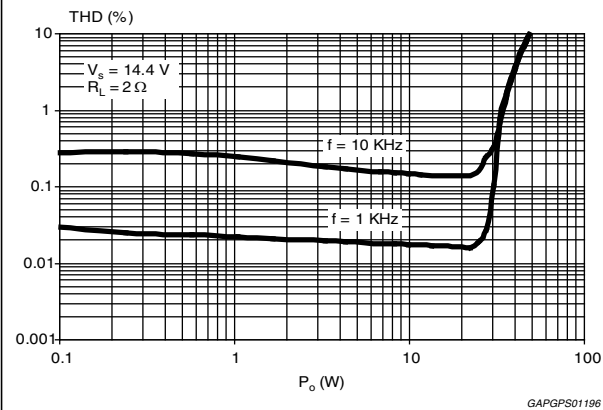

Figure 9. Distortion vs. frequency ($R_L = 4 \Omega$)

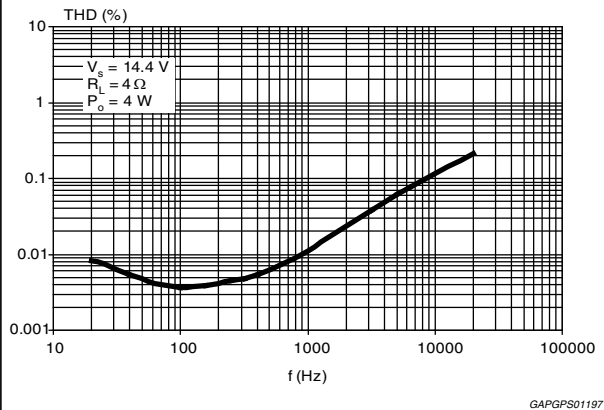

Figure 10. Distortion vs. frequency ($R_L = 2 \Omega$)

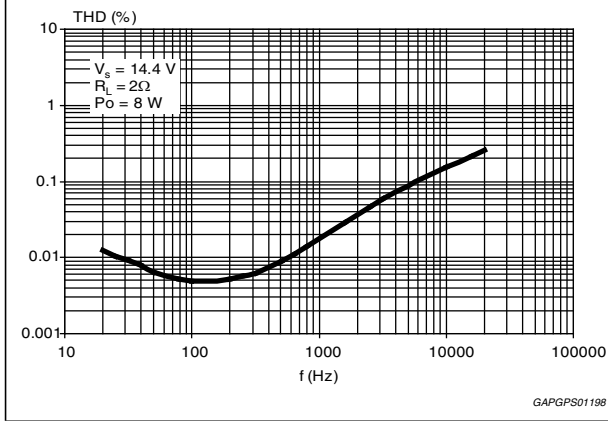

Figure 11. Crosstalk vs. frequency

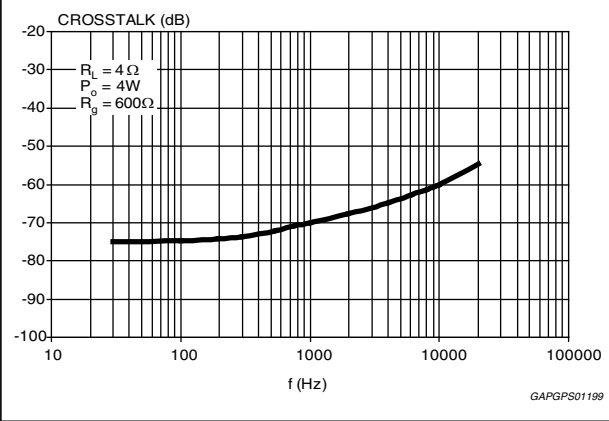

Figure 12. Supply voltage rejection vs. frequency

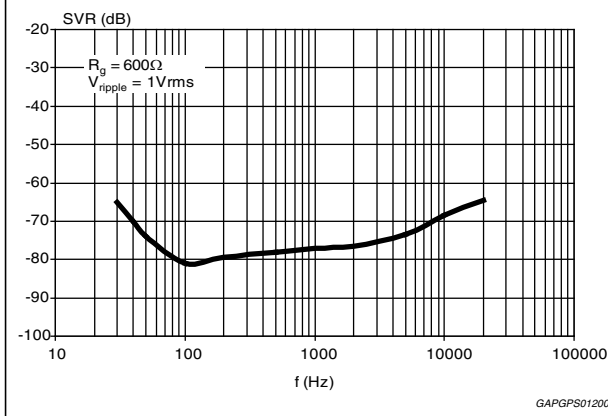

Figure 13. Output attenuation vs. supply voltage

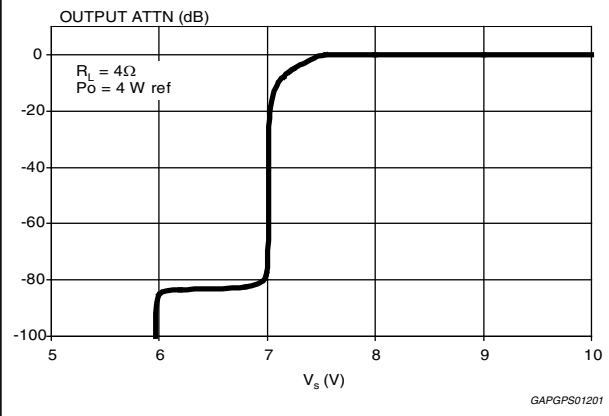

Figure 14. Power dissipation and efficiency vs. output power ($R_L = 4 \Omega$, SINE)

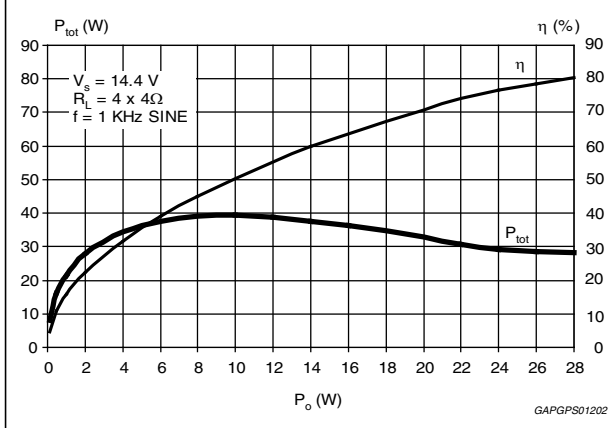

Figure 15. Power dissipation and efficiency vs. output power ($R_L = 2 \Omega$, SINE)

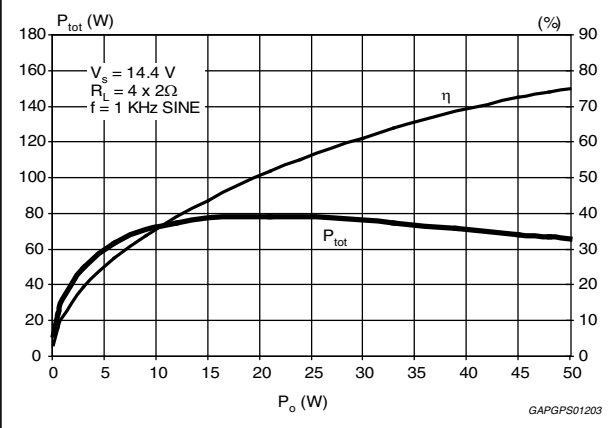

Figure 16. Power dissipation vs. output power ($R_L = 4 \Omega$, audio program simulation)

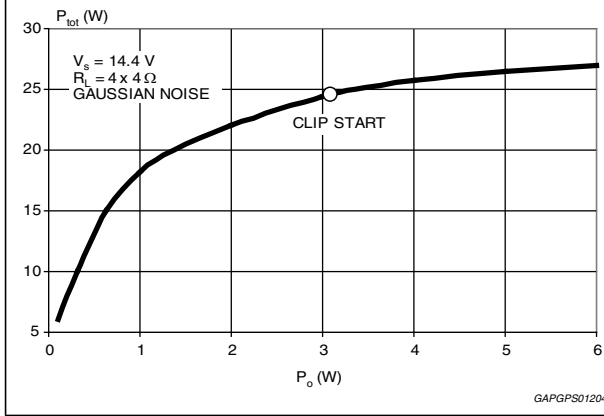

Figure 17. Power dissipation vs. output power ($R_L = 2 \Omega$, audio program simulation)

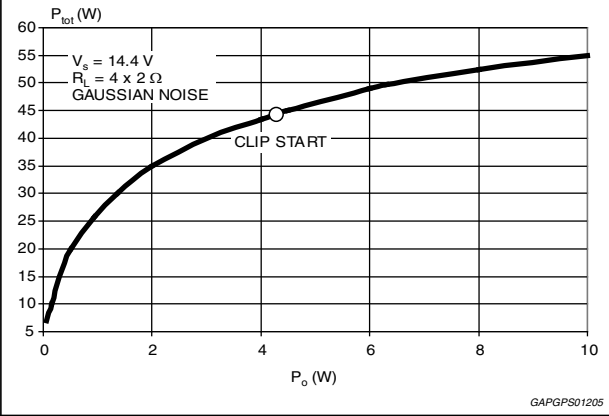
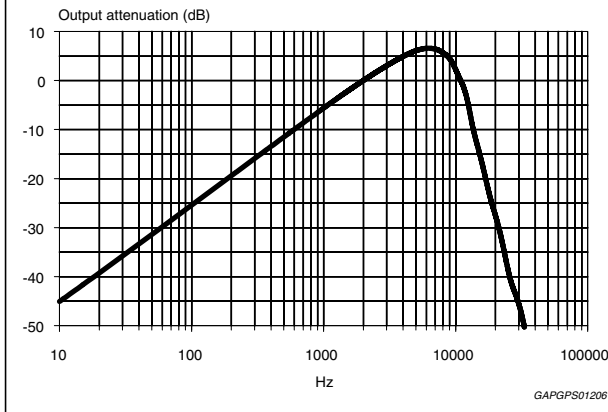

Figure 18. ITU R-ARM frequency response, weighting filter for transient pop



4 Application hints

4.1 SVR

Besides its contribution to the ripple rejection, the SVR capacitor governs the turn ON/OFF time sequence and, consequently, plays an essential role in the pop optimization during ON/OFF transients. To conveniently serve both needs, **its minimum recommended value is 10 μ F**.

4.2 Input stage

The TDA7851's inputs are ground-compatible and can stand very high input signals (± 8 Vpk) without any performance degradation.

If the standard value for the input capacitors (0.1 μ F) is adopted, the low frequency cut-off amounts to 16 Hz.

The input capacitors should be 1/4 of the capacitor connected to AC-GND pin for optimum pop performance.

4.3 Standby and muting

Standby and muting facilities are both CMOS-compatible. In absence of true CMOS ports or microprocessors, a direct connection to Vs of these two pins is admissible but a 470 k Ω equivalent resistance should be present between the power supply and muting and standby pins.

R-C cells have always to be used in order to smooth down the transitions for preventing any audible transient noise.

About standby, the time constant to be assigned in order to obtain a virtually pop-free transition has to be slower than 2.5 V/ms.

4.4 Heatsink definition

Under normal usage (4 Ohm speakers) the heatsink's thermal requirements have to be deduced from [Figure 16](#), which reports the simulated power dissipation when real music/speech programmers are played out. Noise with Gaussian-distributed amplitude was employed for this simulation. Based on that, frequent clipping occurrence (worst-case) causes $P_{diss} = 26$ W. Assuming $T_{amb} = 70$ °C and $T_{CHIP} = 150$ °C as boundary conditions, the heatsink's thermal resistance should be approximately 2 °C/W. This would avoid any thermal shutdown occurrence even after long-term and full-volume operation.

5 Package information

In order to meet environmental requirements, ST offers these devices in different grades of ECOPACK® packages, depending on their level of environmental compliance. ECOPACK® specifications, grade definitions and product status are available at: www.st.com. ECOPACK® is an ST trademark.

5.1 Flexiwatt 25 (vertical) package information

Figure 19. Flexiwatt 25 (vertical) package outline

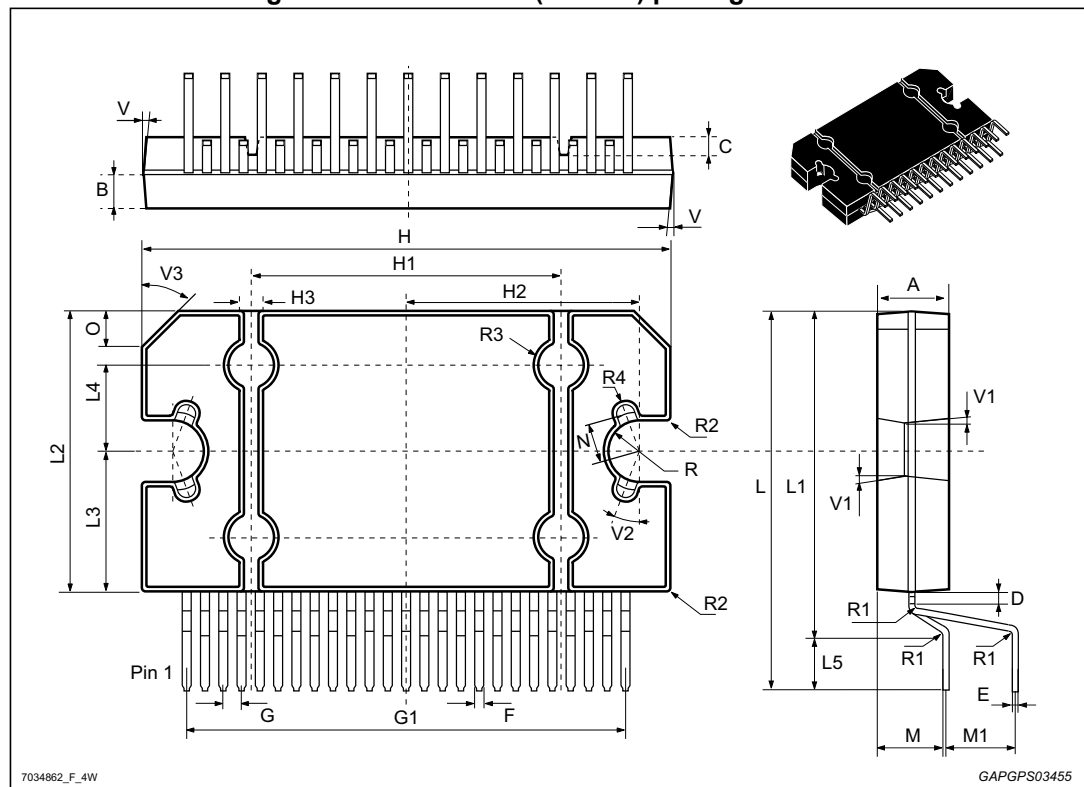

Table 5. Flexiwatt 25 (vertical) package mechanical data

Ref	Dimensions					
	Millimeters			Inches ⁽¹⁾		
	Min.	Typ.	Max.	Min.	Typ.	Max.
A	4.45	4.50	4.65	0.1752	0.1772	0.1831
B	1.80	1.90	2.00	0.0709	0.0748	0.0787
C	-	1.40	-	-	0.0551	-
D	0.75	0.90	1.05	0.0295	0.0354	0.0413
E	0.37	0.39	0.42	0.0146	0.0154	0.0165

Table 5. Flexiwatt 25 (vertical) package mechanical data (continued)

Ref	Dimensions					
	Millimeters			Inches ⁽¹⁾		
	Min.	Typ.	Max.	Min.	Typ.	Max.
F ⁽²⁾	-	-	0.570	-	-	0.0224
G	0.80	1.00	1.20	0.0315	0.0394	0.0472
G1	23.75	24.00	24.25	0.9350	0.9449	0.9547
H ⁽³⁾	28.90	29.23	29.30	1.1378	1.1508	1.1535
H1	-	17.00	-	-	0.6693	-
H2	-	12.80	-	-	0.5039	-
H3	-	0.80	-	-	0.0315	-
L	22.07	22.47	22.87	0.8689	0.8846	0.9004
L1	18.57	18.97	19.37	0.7311	0.7469	0.7626
L2 ⁽³⁾	15.50	15.70	15.90	0.6102	0.6181	0.6260
L3	7.70	7.85	7.95	0.3031	0.3091	0.3130
L4	-	5.00	-	-	0.1969	-
L5	3.35	3.50	3.65	0.1319	0.1378	0.1437
M	3.70	4.00	4.30	0.1457	0.1575	0.1693
M1	3.60	4.00	4.40	0.1417	0.1575	0.1732
N	-	2.20	-	-	0.0866	-
O	-	2.00	-	-	0.0787	-
R	-	1.70	-	-	0.0669	-
R1	-	0.50	-	-	0.0197	-
R2	-	0.30	-	-	0.0118	-
R3	-	1.25	-	-	0.0492	-
R4	-	0.50	-	-	0.0197	-
V	5°			5°		
V1	3°			3°		
V2	20°			20°		
V3	45°			45°		

1. Values in inches are converted from mm and rounded to 4 decimal digits.
2. Dam-bar protusion not included.
3. Molding protusion included.

5.2 Flexiwatt 25 (horizontal) package information

Figure 20. Flexiwatt 25 (horizontal) package outline

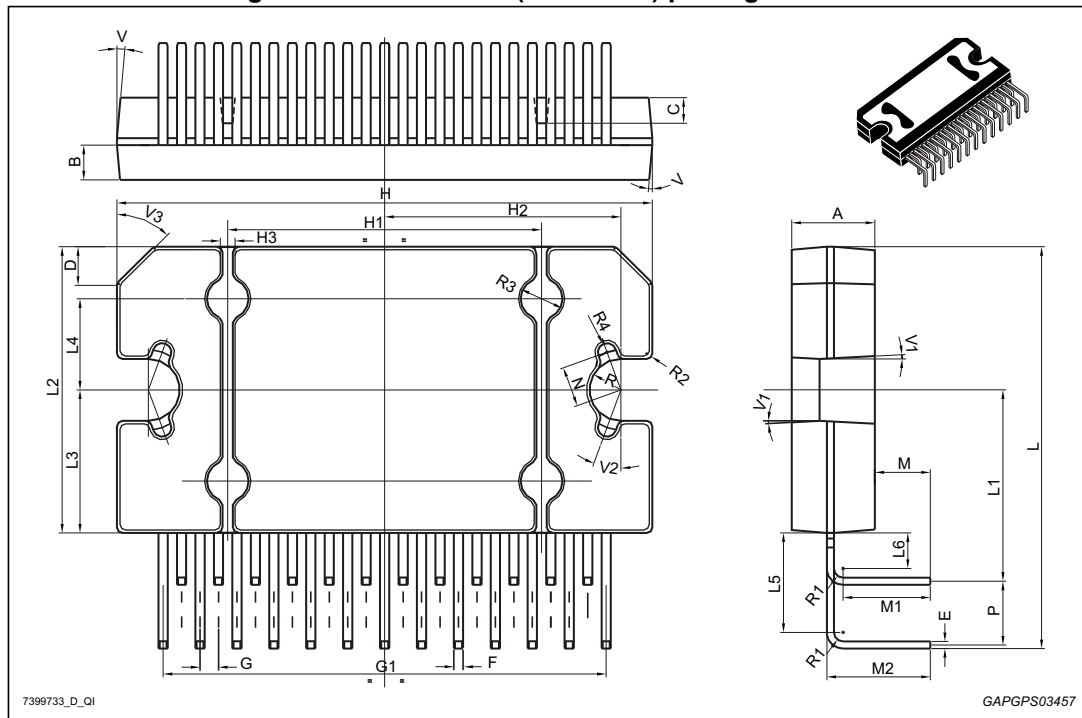

Table 6. Flexiwatt 25 (horizontal) package mechanical data

Ref	Dimensions					
	Millimeters			Inches ⁽¹⁾		
	Min.	Typ.	Max.	Min.	Typ.	Max.
A	4.45	4.50	4.65	0.1752	0.1772	0.1831
B	1.80	1.90	2.00	0.0709	0.0748	0.0787
C	-	1.40	-	-	0.0551	-
D	-	2.00	-	-	0.0787	-
E	0.37	0.39	0.42	0.0146	0.0154	0.0165
F ⁽²⁾	-	-	0.57	-	-	0.0224
G	0.75	1.00	1.25	0.0295	0.0394	0.0492
G1	23.70	24.00	24.30	0.9331	0.9449	0.9567
H ⁽³⁾	28.90	29.23	29.30	1.1378	1.1508	1.1535
H1	-	17.00	-	-	0.6693	-
H2	-	12.80	-	-	0.5039	-
H3	-	0.80	-	-	0.0315	-
L	21.64	22.04	22.44	0.8520	0.8677	0.8835

Table 6. Flexiwatt 25 (horizontal) package mechanical data (continued)

Ref	Dimensions					
	Millimeters			Inches ⁽¹⁾		
	Min.	Typ.	Max.	Min.	Typ.	Max.
L1	10.15	10.5	10.85	0.3996	0.4134	0.4272
L2 ⁽³⁾	15.50	15.70	15.90	0.6102	0.6181	0.6260
L3	7.70	7.85	7.95	0.3031	0.3091	0.3130
L4	-	5	-	-	0.1969	-
L5	5.15	5.45	5.85	0.2028	0.2146	0.2303
L6	1.80	1.95	2.10	0.0709	0.0768	0.0827
M	2.75	3.00	3.50	0.1083	0.1181	0.1378
M1	-	4.73	-	-	0.1862	-
M2	-	5.61	-	-	0.2209	-
N	-	2.20	-	-	0.0866	-
P	3.20	3.50	3.80	0.1260	0.1378	0.1496
R	-	1.70	-	-	0.0669	-
R1	-	0.50	-	-	0.0197	-
R2	-	0.30	-	-	0.0118	-
R3	-	1.25	-	-	0.0492	-
R4	-	0.50	-	-	0.0197	-
V	5°			5°		
V1	3°			3°		
V2	20°			20°		
V3	45°			45°		

1. Values in inches are converted from mm and rounded to 4 decimal digits.
2. Dam-bar protusion not included.
3. Molding protusion included.

6 Revision history

Table 7. Document revision history

Date	Revision	Changes
09-Jul-2010	1	Initial release.
13-Jun-2012	2	Updated: <i>Features on page 1</i> ; <i>Section 3.2: Electrical characteristics on page 7</i> .
18-Sep-2013	3	Updated disclaimer.
05-Feb-2016	4	Updated <i>Table 1: Device summary on page 1</i> (added new order code). Updated <i>Section 5: Package information</i> (added Flexiwatt25 horizontal package information).

IMPORTANT NOTICE – PLEASE READ CAREFULLY

STMicroelectronics NV and its subsidiaries (“ST”) reserve the right to make changes, corrections, enhancements, modifications, and improvements to ST products and/or to this document at any time without notice. Purchasers should obtain the latest relevant information on ST products before placing orders. ST products are sold pursuant to ST’s terms and conditions of sale in place at the time of order acknowledgement.

Purchasers are solely responsible for the choice, selection, and use of ST products and ST assumes no liability for application assistance or the design of Purchasers’ products.

No license, express or implied, to any intellectual property right is granted by ST herein.

Resale of ST products with provisions different from the information set forth herein shall void any warranty granted by ST for such product.

ST and the ST logo are trademarks of ST. All other product or service names are the property of their respective owners.

Information in this document supersedes and replaces information previously supplied in any prior versions of this document.

© 2016 STMicroelectronics – All rights reserved



Компания «ЭлектроПласт» предлагает заключение долгосрочных отношений при поставках импортных электронных компонентов на взаимовыгодных условиях!

Наши преимущества:

- Оперативные поставки широкого спектра электронных компонентов отечественного и импортного производства напрямую от производителей и с крупнейших мировых складов;
- Поставка более 17-ти миллионов наименований электронных компонентов;
- Поставка сложных, дефицитных, либо снятых с производства позиций;
- Оперативные сроки поставки под заказ (от 5 рабочих дней);
- Экспресс доставка в любую точку России;
- Техническая поддержка проекта, помощь в подборе аналогов, поставка прототипов;
- Система менеджмента качества сертифицирована по Международному стандарту ISO 9001;
- Лицензия ФСБ на осуществление работ с использованием сведений, составляющих государственную тайну;
- Поставка специализированных компонентов (Xilinx, Altera, Analog Devices, Intersil, Interpoint, Microsemi, Aeroflex, Peregrine, Syfer, Eurofarad, Texas Instrument, Miteq, Cobham, E2V, MA-COM, Hittite, Mini-Circuits, General Dynamics и др.);

Помимо этого, одним из направлений компании «ЭлектроПласт» является направление «Источники питания». Мы предлагаем Вам помощь Конструкторского отдела:

- Подбор оптимального решения, техническое обоснование при выборе компонента;
- Подбор аналогов;
- Консультации по применению компонента;
- Поставка образцов и прототипов;
- Техническая поддержка проекта;
- Защита от снятия компонента с производства.



Как с нами связаться

Телефон: 8 (812) 309 58 32 (многоканальный)

Факс: 8 (812) 320-02-42

Электронная почта: org@eplast1.ru

Адрес: 198099, г. Санкт-Петербург, ул. Калинина, дом 2, корпус 4, литера А.