

# ICB2FL02G

## Smart Ballast Control IC for Fluorescent Lamp Ballasts

Published by Infineon Technologies AG  
<http://www.infineon.com>

**Power Management & Drives**



Never stop thinking

**ICB2FL02G**

<b>Revision History</b>		
<b>Preliminary Datasheet ICB2FL02G</b>		
Actual Release: V1.2 Date: 08.02.2010		Previous Release: V1.1 - 17.03.2009
Page of actual Rel.	Page of prev. Rel.	Subjects changed since last release
3	3	Updated Product Highlights; Updated Description
14	14	Text Update: R41, R42 and R43 → R41, R42,R43 and R44
23	23	Figure 17 update
25	25	Text Update: R41, R42 and R43 → R41, R42,R43 and R44
26	26	Text Update: R41, R42 and R43 → R41, R42,R43 and R44
29	29	Chapter 2.6.2 Text and Figure update
39	39	Figure 37 Additional explanation in the Diagram
40	40	Update Protection Function Matrix open filament LS → open filament HS @ LVS1
47	47	Chapter 5.3.3.1 Footnote Update
51	51	Enlarged tolerance for Customer Test Mode
53	53	Chapter 6.2: BOM Update deleted Partnumbers of MOSFETs

For questions on technology, delivery and prices please contact the Infineon Technologies Offices in Germany or the Infineon Technologies Companies and Representatives worldwide: see the address list on the last page or our webpage at <http://www.infineon.com>

**Published by**  
**Infineon Technologies AG**  
**81726 Munich, Germany**  
**© 2007 Infineon Technologies AG**  
**All Rights Reserved.**

**Legal Disclaimer**

The information given in this document shall in no event be regarded as a guarantee of conditions or characteristics. With respect to any examples or hints given herein, any typical values stated herein and/or any information regarding the application of the device, Infineon Technologies hereby disclaims any and all warranties and liabilities of any kind, including without limitation, warranties of non-infringement of intellectual property rights of any third party.

**Information**

For further information on technology, delivery terms and conditions and prices, please contact the nearest Infineon Technologies Office ([www.infineon.com](http://www.infineon.com)).

**Warnings**

Due to technical requirements, components may contain dangerous substances. For information on the types in question, please contact the nearest Infineon Technologies Office. Infineon Technologies components may be used in life-support devices or systems only with the express written approval of Infineon Technologies, if a failure of such components can reasonably be expected to cause the failure of that life-support device or system or to affect the safety or effectiveness of that device or system. Life support devices or systems are intended to be implanted in the human body or to support and/or maintain and sustain and/or protect human life. If they fail, it is reasonable to assume that the health of the user or other persons may be endangered.

## 2<sup>nd</sup> Generation FL-Controller for Fluorescent Lamp Ballasts

### Product Highlights

- Lowest Count of external Components
- 900V-Half-Bridge driver with coreless Transformer Technology
- Supports Customer In-Circuit Test Mode for reduced Tester Time
- Supports Multi-Lamp Designs
- Integrated digital Timers up to 40 seconds
- Numerous Monitoring and Protection Features for highest Reliability
- Very high accuracy of frequencies and timers over the whole temperature range
- Very low standby losses
- Special detection thresholds for dimming applications

### Features PFC

- Discontinuous Mode PFC for Load Range 0 to 100%
- Integrated digital Compensation of PFC Control Loop
- Improved Compensation for low THD of AC Input Current also in DCM Operation
- Adjustable PFC Current Limitation

### Features Lamp Ballast Inverter

- Adjustable Detection of Overload and Rectifier Effect (EOL)
- Detection of Capacitive Load operation
- Improved Ignition Control allows Operation close to the magnetic Saturation of the lamp Inductors
- Restart with skipped Preheating at short interruptions of Line Voltage (for Emergency Lighting)
- Parameters adjustable by Resistors only
- Pb-free Lead Plating; RoHS compliant

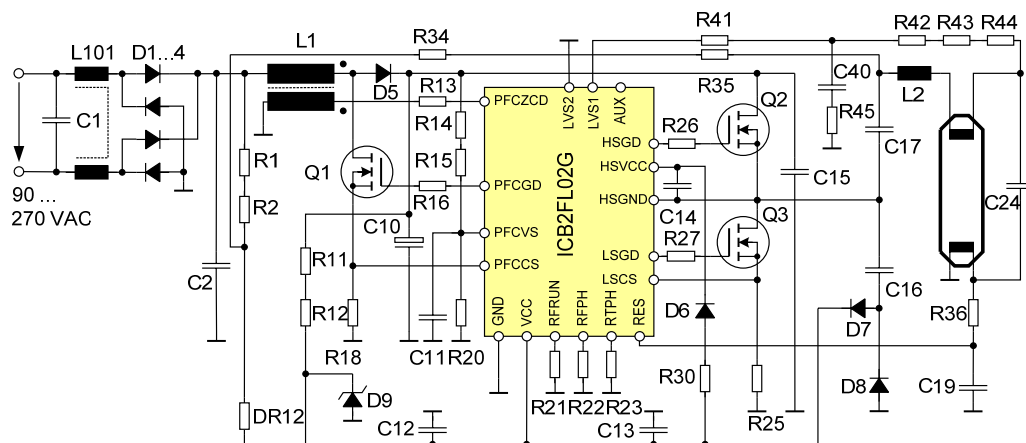

Figure 1 Typical Application Circuit of Ballast for a single Fluorescent Lamp

### Description

The FL-Controller ICB2FL02G is designed to control fluorescent lamp ballast including a discontinuous mode Power Factor Correction (PFC), a lamp inverter control and a high voltage level shift half-bridge driver with special detection thresholds for dimming applications. The control concept covers requirements for T5 lamp ballasts for single and multi-lamp designs. ICB2FL02G is based on the 2<sup>nd</sup> Generation FL-Controller Technology, is easy to use and simply to design in. Therefore a basis for a cost effective solution for fluorescent lamp ballasts of high reliability. Figure 1 shows a typical application circuit of ballast for a single fluorescent T8 lamp with current mode preheating.

## Table of Contents

<b>1</b>	<b>Pin Configuration and Description.....</b>	<b>6</b>
1.1	<i>Pin Configuration.....</i>	6
1.2	<i>Pin Description.....</i>	6
<b>2</b>	<b>Functional Description .....</b>	<b>11</b>
2.1	<i>Typical Application Circuitry.....</i>	11
2.2	<i>Normal Start Up .....</i>	12
2.2.1	Operating Levels from UVLO to Soft Start.....	13
2.2.2	Operating Levels from Soft Start to Run Mode.....	15
2.3	<i>Filament Detection during Start Up and Run Mode.....</i>	17
2.3.1	Start Up with broken Low Side Filament.....	17
2.3.2	Low Side Filament Detection during Run Mode.....	18
2.3.3	Start Up with broken High Side Filament.....	19
2.4	<i>PFC Pre Converter.....</i>	20
2.4.1	Discontinuous Conduction and Critical Conduction Mode Operation.....	20
2.4.2	PFC Bus Voltage Sensing.....	21
2.4.2.1	Bus Over Voltage and PFC Open Loop.....	21
2.4.2.2	Bus Voltage 95% and 75% Sensing.....	21
2.4.3	PFC Structure of Mixed Signal.....	22
2.4.4	THD Correction via ZCD Signal.....	23
2.4.5	Optional THD Correction dedicated for DCM Operation.....	24
2.5	<i>Detection of End-of-Life and Rectifier Effect.....</i>	25
2.5.1	Detection of End of Life 1 (EOL1) – Lamp Overvoltage.....	25
2.5.2	Detection of End of Life 2 (EOL2) – Rectifier Effect.....	26
2.6	<i>Detection of Capacitive Load.....</i>	27
2.6.1	Capacitive Load 2 (Over Current / Operation below Resonance).....	28
2.6.2	Adjustable self adapting Dead Time.....	29
2.7	<i>Emergency Lighting.....</i>	30
2.7.1	Short Term PFC Bus Under Voltage.....	31
2.7.2	Long Term PFC Bus Under Voltage.....	32
2.8	<i>Built in Customer Test Mode Operation.....</i>	33
2.8.1	Pre Heating Test Mode.....	33
2.8.1.1	Skip the Pre Heating Phase – Set RTPH Pin to GND.....	33
2.8.1.2	IC remains in Pre Heating Phase.....	34
2.8.2	Deactivation of the Filament Detection.....	35
2.8.3	Built in Customer Test Mode (Clock Acceleration).....	36
2.8.3.1	Enabling of the Clock Acceleration.....	36
2.8.3.2	Starting the Chip with accelerated Clock.....	36
<b>3</b>	<b>State Diagram .....</b>	<b>37</b>
3.1	<i>Features during different operating modes.....</i>	37
3.2	<i>Operating Flow of the Start UP Procedure into the Run Mode.....</i>	38
3.3	<i>Auto Restart and Latched Fault Condition Mode.....</i>	39
<b>4</b>	<b>Protection Functions Matrix.....</b>	<b>40</b>
<b>5</b>	<b>Electrical Characteristics .....</b>	<b>41</b>

<b>5.1</b>	<b><i>Absolute Maximum Ratings</i></b> .....	<b>41</b>
<b>5.2</b>	<b><i>Operating Range</i></b> .....	<b>43</b>
<b>5.3</b>	<b><i>Characteristics</i></b> .....	<b>44</b>
5.3.1	<i>Power Supply Section</i> .....	44
5.3.2	<i>PFC Section</i> .....	45
5.3.2.1	<i>PFC Current Sense (PFCCS)</i> .....	45
5.3.2.2	<i>PFC Zero Current Detection (PFCZCD)</i> .....	45
5.3.2.3	<i>PFC Bus Voltage Sense (PFCVS)</i> .....	45
5.3.2.4	<i>PFC PWM Generation</i> .....	46
5.3.2.5	<i>PFC Gate Drive (PFCGD)</i> .....	46
5.3.2.6	<i>Auxiliary (AUX)</i> .....	46
5.3.3	<i>Inverter Section</i> .....	47
5.3.3.1	<i>Low Side Current Sense (LSCS)</i> .....	47
5.3.3.2	<i>Low Side Gate Drive (LSGD)</i> .....	48
5.3.3.3	<i>Inverter Control Run (RFRUN)</i> .....	49
5.3.3.4	<i>Inverter Control Preheating (RFPH, RTPH)</i> .....	49
5.3.3.5	<i>Restart after Lamp Removal (RES)</i> .....	50
5.3.3.6	<i>Lamp Voltage Sense (LVS1, LVS2)</i> .....	50
5.3.3.7	<i>High Side Gate Drive (HSGD)</i> .....	51
5.3.3.8	<i>Timer Section</i> .....	51
5.3.3.9	<i>Built in Customer Test Mode</i> .....	51
<b>6</b>	<b><i>Application Example</i></b> .....	<b>52</b>
6.1	<i>Schematic Ballast 54W T5 Single Lamp</i> .....	52
6.2	<i>Bill of Material</i> .....	53
6.3	<i>Multi Lamp Ballast Topologies</i> .....	54
<b>7</b>	<b><i>Package Outlines</i></b> .....	<b>55</b>

# 1 Pin Configuration and Description

## 1.1 Pin Configuration

Pin	Symbol	Function
1	LSCS	Low side current sense (inverter)
2	LSGD	Low side Gate drive (inverter)
3	V <sub>CC</sub>	Supply voltage
4	GND	Low side Ground
5	PFCGD	PFC Gate drive
6	PFCCS	PFC current sense
7	PFCZCD	PFC zero current detector
8	PFCVS	PFC voltage sense
9	RFRUN	Set R for run frequency
10	RFPH	Set R for preheat frequency
11	RTPH	Set R for preheating time
12	RES	Restart after lamp removal
13	LVS1	Lamp voltage sense 1
14	LVS2	Lamp voltage sense 2
15	AUX	Auxiliary output
16		Creepage distance
17	HSGND	High side ground
18	HSVCC	High side supply voltage
19	HSGD	High side Gate drive (inverter)
20		Not connected

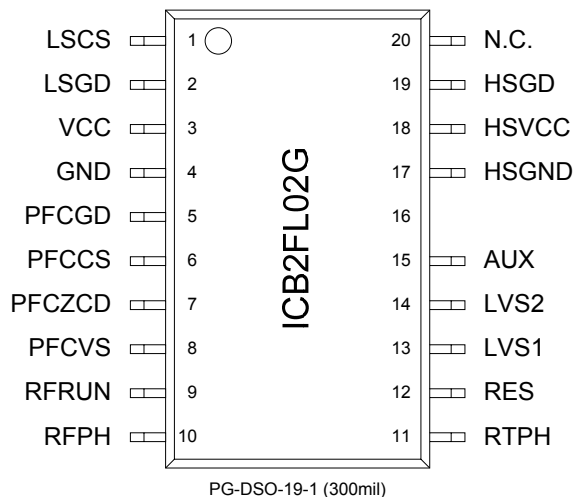

Figure 2 Package PG-DSO-19-1

## 1.2 Pin Description

### LSCS (Low-side current sense, Pin 1)

This pin is directly connected to the shunt resistor which is located between the Source terminal of the low-side MOSFET of the inverter and ground.

Internal clamping structures and filtering measures allow for sensing the Source current of the low side inverter MOSFET without additional filter components.

There is a first threshold of 0.8V. If this threshold is exceeded for longer than 500ns during preheat or run mode, an inverter over current is detected and causes a latched shut down of the IC. The ignition control is activated if the sensed slope at the LSCS pin reaches typically 205 mV/μs ± 25 mV/μs and exceeds the 0.8V threshold. This stops the decreasing of the frequency and waits for ignition. The ignition control is now continuously monitored by the LSCS PIN. The Ignition control is designed to handle a choke operation in saturation while ignition in order to reduce the choke size.

If the sensed current signal exceeds a second threshold of 1.6V for longer than 500ns during start-up, soft start, ignition mode and pre-run, the IC changes over into a latched shut down.

There are further thresholds active at this pin during run mode that detects a capacitive mode operation. A threshold of -50mV senses the current before the high-side MOSFET is turned on. A voltage level below of this threshold indicates a faulty operation (Capload 2). Finally a second threshold at 2.0 V senses even short overcurrent during turn-on of the high-side MOSFET such as they are typical for reverse recovery currents of a diode (Capload 2). If one of these comparator thresholds indicate wrong operating conditions for longer than 620μs (Capload 2) in run mode, the IC turns off the Gates and changes into fault mode due to detected capacitive mode operation (non-zero voltage switching).

The threshold of -50mV is also used to adjust the dead time between turn-off and turn-on of the half-bridge drivers in a range of 1.05μs to 2.0μs during all operating modes.

### LSGD (Low-side Gate drive, Pin 2)

The Gate of the low-side MOSFET in a half-bridge inverter topology is controlled by this pin. There is an active L-level during UVLO (under voltage lockout) and a limitation of the max H-level at 11.0 V during normal operation. In order to turn-on the MOSFET softly (with a reduced  $di_{DRAIN}/dt$ ); the Gate voltage rises within 220ns typically from L-level to H-level. The fall time of the Gate voltage is less than 50ns in order to turn off quickly. This measure produces different switching speeds during turn-on and turn-off as it is usually achieved with a diode parallel to a resistor in the Gate drive loop. It is recommended to use a resistor of typically 10Ω between drive pin and Gate in order to avoid oscillations and in order to shift the power dissipation of discharging the Gate capacitance into this resistor. The dead time between LSGD signal and HSGD signal is self adapting between 1.05μs and 2.0μs.

### V<sub>CC</sub> (Supply voltage, Pin 3)

This pin provides the power supply of the ground related section of the IC. There is a turn-on threshold at 14.1V and an UVLO threshold at 10.6V. Upper supply voltage level is 17.5V. There is an internal zener diode clamping V<sub>CC</sub> at 16.3V (at I<sub>VCC</sub>=2mA typically). The maximum zener current is internally limited to 5mA. For higher current levels an external zener diode is required. Current consumption during UVLO and during fault mode is less than 170μA. A ceramic capacitor close to the supply and GND pin is required in order to act as a low-impedance power source for Gate drive and logic signal currents. In order to use a skipped preheating after short interruptions of mains supply it is necessary to feed the start-up current (160μA) from the bus voltage. Note: for external V<sub>CC</sub> supply see notes in flowchart chapter 3.3.

### GND (Ground, Pin 4)

This pin is connected to ground and represents the ground level of the IC for supply voltage, Gate drive and sense signals.

### PFCGD (PFC Gate drive, Pin 5)

The Gate of the MOSFET in the PFC preconverter designed in boost topology is controlled by this pin. There is an active L-level during UVLO and a limitation of the max H-level at 11.0 V during normal operation. In order to turn-on the MOSFET softly (with a reduced  $di_{DRAIN}/dt$ ), the Gate drive voltage rises within 220ns from L-level to H-level.

The fall time of the Gate voltage is less than 50ns in order to turn off quickly.

A resistor of typically 10Ω between drive pin and Gate in order to avoid oscillations and in order to shift the power dissipation of discharging the Gate capacitance into this resistor is recommended.

The PFC section of the IC controls a boost converter as a PFC preconverter in discontinuous conduction mode (DCM). Typically the control starts with Gate drive pulses with a fixed on-time of typically 4.0μs at V<sub>ACIN</sub> = 230V increasing up to 22.7μs and with an off-time of 47μs. As soon as sufficient zero current detector (ZCD) signals are available, the operation mode changes from a fixed frequent operation to an operation with variable frequency. The PFC works in a critical conduction mode operation (CritCM) when rated and / or medium load conditions are present. That means triangular shaped currents in the boost converter choke without gaps and variable operating frequency. During low load (detected by an internal compensator) we get an operation with discontinuous conduction mode (DCM) that means triangular shaped currents in the boost converter choke with gaps when reaching the zero current level and variable operating frequency in order to avoid steps in the consumed line current.

### PFCCS (PFC current sense, Pin 6)

The voltage drop across a shunt resistor located between Source of the PFC MOSFET and GND is sensed with this pin. If the level exceeds a threshold of 1.0 V for longer than 200ns the PFC Gate drive is turned off as long as the zero current detector (ZCD) enables a new cycle. If there is no ZCD signal available within 52μs after turn-off of the PFC Gate drive, a new cycle is initiated from an internal start-up timer.

### PFCZCD (PFC zero current detector, Pin 7)

This pin senses the point of time when the current through boost inductor becomes zero during off-time of the PFC MOSFET in order to initiate a new cycle.

The moment of interest appears when the voltage of the separate ZCD winding changes from positive to negative level which represents a voltage of zero at the inductor windings and therefore the end of current flow from lower input voltage level to higher output voltage level. There is a threshold with hysteresis, for increasing level 1.5V, for decreasing level 0.5V, which detects the change of inductor voltage.

A resistor, connected between ZCD winding and PIN 7, limits the sink and source current of the sense pin when the voltage of the ZCD winding exceeds the internal clamping levels (6.3V and -2.9V typically @ 5mA) of the IC.

If the sensed voltage level of the ZCD winding is not sufficient (e.g. during start-up), an internal start-up timer will initiate a new cycle every 52µs after turn-off of the PFC Gate drive. The source current out of this pin during the on-time of the PFC-MOSFET indicates the voltage level of the AC supply voltage. During low input voltage levels the on-time of the PFC-MOSFET is enlarged in order to minimize gaps in the line current during zero crossing of the line voltage and improve the THD (Total Harmonic Distortion) of the line current. An optimization of the THD is possible by trimming of the resistor between this pin and the ZCD-winding.

### PFCVS (PFC voltage sense, Pin 8)

The intermediate circuit voltage (bus voltage) at the smoothing capacitor is sensed by a resistive divider at this pin. The internal reference voltage for rated bus voltage is 2.5V. There are further thresholds at 0.3125V (12.5% of rated bus voltage) for the detection of open control loop and at 1.875V (75% of rated bus voltage) for the detection of an under voltage and at 2.725V (109% of rated bus voltage) for the detection of an overvoltage. The overvoltage threshold operates with a hysteresis of 100mV (4% of rated bus voltage). For the detection of a successful start-up the bus voltage is sensed at 95% (2.375V). It is recommended to use a small capacitor between this pin and GND as a spike suppression filter.

In run mode, a PFC overvoltage stops the PFC Gate drive within 5µs. As soon as the bus voltage is less than 105% of rated level, the Gate drives are enabled again. If the overvoltage lasts for longer than 625ms, an inverter overvoltage is detected and turns off the inverter the gate drives also. This causes a power down and a power up when  $V_{BUS} < 109\%$ . A bus under- ( $V_{BUS} > 75\%$ ) or inverter overvoltage during run mode is handled as fault U. In this situation the IC changes into power down mode and generates a delay of 100ms by an internal timer. Then start-up conditions are checked and if valid, a further start-up is initiated. If start-up conditions are not valid, a further delay of 100ms is generated.

This procedure is repeated maximum seven times. If a start-up is successful within these seven cycles, the situation is interpreted as a short interruption of mains supply and the preheating is skipped. Any further start-up attempt is initiated including the preheating.

### RFRUN (Set R for run frequency, Pin 9)

A resistor from this pin to ground sets the operating frequency of the inverter during run mode. Typical run frequency range is 20 kHz to 120 kHz. The set resistor  $R_{RFRUN}$  can be calculated based on the run frequency  $f_{RUN}$  according to the equation:

$$R_{RFRUN} = \frac{5 \cdot 10^8 \Omega Hz}{f_{RUN}}$$

### RFPH (Set R for preheat frequency, Pin 10)

A resistor from this pin to ground sets together with the resistor at pin 9 the operating frequency of the inverter during preheat mode. Typical preheat frequency range is run frequency (as a minimum) to 150 kHz. The set resistor  $R_{RFPH}$  can be calculated based on the preheat frequency  $f_{PH}$  and the resistor  $R_{RFRUN}$  according to the equation:

$$R_{RFPH} = \frac{R_{RFRUN}}{\frac{f_{PH} \cdot R_{RFRUN}}{5 \cdot 10^8 \Omega Hz} - 1}$$

### RTPH (Set R for preheating time, Pin 11)

A resistor from this pin to ground sets the preheating time of the inverter during preheat mode. A set resistor range from zero to 25kΩ corresponds to a range of preheating time from zero to 2500ms subdivided in 127 steps.

$$R_{RTPH} = \frac{t_{PreHeating}}{100 \frac{ms}{k\Omega}}$$

### RES (Restart, Pin 12)

A source current out of this pin via resistor and filament to ground monitors the existence of the low-side filament of the fluorescent lamp for restart after lamp removal. A capacitor from this pin directly to ground eliminates a superimposed AC voltage that is generated as a voltage drop across the low-side filament. With a second sense resistor the filament of a paralleled lamp can be included into the lamp removal sense. Note: during start up, the chip supply voltage  $V_{CC}$  has to be below 14.1V before  $V_{RES}$  reaches the filament detection level.



During typical start-up with connected filaments of the lamp a current source  $I_{RES3}$  ( $-21.3 \mu\text{A}$ ) is active as long as  $V_{CC} > 10.6\text{V}$  and  $V_{RES} < V_{RES1}$  ( $1.6\text{V}$ ). An open low-side filament is detected, when  $V_{RES} > V_{RES1}$ . Such a condition will prevent the start-up of the IC. In addition the comparator threshold is set to  $V_{RES2}$  ( $1.3\text{V}$ ) and the current source changes to  $I_{RES4}$  ( $-17.7 \mu\text{A}$ ). Now the system is waiting for a voltage level lower than  $V_{RES2}$  at the RES pin that indicates a connected low-side filament, which will enable the start-up of the IC.

An open high-side filament is detected when there is no sink current  $I_{LVSSINK}$  ( $>18 \mu\text{A}$ ) into both of the LVS pins before the  $V_{CC}$  Start-up threshold is reached. Under these conditions the current source at the RES pin is  $I_{RES1}$  ( $-42.6 \mu\text{A}$ ) as long as  $V_{CC} > 10.6\text{V}$  and  $V_{RES} < V_{RES1}$  ( $1.6\text{V}$ ) and the current source is  $I_{RES2}$  ( $-35.4 \mu\text{A}$ ) when the threshold has changed to  $V_{RES2}$  ( $1.3\text{V}$ ). In this way the detection of the high-side filament is mirrored to the levels on the RES pin.

There is a further threshold of  $3.2\text{V}$  active at the RES pin during run mode. If the voltage level rises above this threshold for longer than  $620\mu\text{s}$ , the IC changes over into latched fault mode.

In any case of fault detection with different reaction times the IC turns-off the Gate drives and changes into power down mode with a current consumption of  $170 \mu\text{A}$  max. An internal timer generates a delay time of  $200 \text{ms}$ , before start-up conditions are checked again. As soon as start-up conditions are valid, a second start-up attempt is initiated. If this second attempt fails, the IC remains in latched fault mode until a reset is generated by UVLO or lamp removal. The RES PIN can be deactivated via set the PIN to GND (durable).

### LVS1 (Lamp voltage sense 1, Pin 13)

Before start-up this pin senses a current fed from the rectified line voltage via resistors through the high-side filaments of the lamp for the detection of an inserted lamp.

The sensed current fed into the LVS pin has to exceed  $12 \mu\text{A}$  typically at a voltage level of  $6.0 \text{V}$  at the LVS pin. The reaction on the high side filament detection is mirrored to the RES pin (see pin 12). In addition the detection of available mains supply after an interruption is sensed by this pin. Together with pin LVS2 and pin RES the IC can monitor the lamp removal of totally four lamps. If the functionality of this pin is not required, e.g. for single lamp designs, it can be disabled by connecting this pin to ground.

During run mode the lamp voltage is monitored with this pin by sensing a current proportional to the lamp voltage via resistors. An overload is indicated by an excessive lamp voltage. If the peak to peak lamp voltage effects a peak to peak current above a threshold of  $210\mu\text{A}_{PP}$  for longer than  $620\mu\text{s}$ , a fault EOL1 (end-of-life) is assumed. If the DC current at the LVS pin exceeds a threshold of  $\pm 42\mu\text{A}$  for longer than  $2500\text{ms}$ , a fault EOL2 (rectifier effect) is assumed. The levels of AC sense current and DC sense current can be set separately by external RC network. Note, in case of a deactivation of the LVS1/2 PIN, a reactivation starts, when the voltage at LVS1/2 PIN exceeds  $V_{LVSEnable1}$  in RUN Mode.

### LVS2 (Lamp voltage sense 2, Pin 14)

LVS2 has the same functionality as pin LVS1 for monitoring in parallel an additional lamp circuitry.

### AUX (Auxiliary output, Pin 15)

This pin provides a control current for a NPN bipolar transistor during DCM operating mode of the PFC section. There is a source current of  $-450\mu\text{A}$  plus the current which is fed into pin PFCZCD from the detector winding available only during the enlarged off-time. That differ the discontinuous conduction mode (DCM) from the critical conduction mode (CritCM). With this transistor a resistor for damping oscillations can be switched to the ZCD winding in order to minimize the line current harmonics during DCM operating mode. If this function is not used, this pin has to be not connected.

### Pin 16 Not Existing

PIN 16 does not exist, in order to provide a wider creepage distance to the high-side gate driver. Please pay attention to relevant standards.

### HSGND (High-side ground, Pin 17)

This pin is connected to the Source terminal of the high-side MOSFET which is also the node of high-side and low-side MOSFET. This pin represents the floating ground level of the high-side driver and the high-side supply.

**HSVCC (High-side supply voltage, Pin 18)**

This pin provides the power supply of the high-side ground related section of the IC. An external capacitor between pin 17 and pin 18 acts like a floating battery which has to be recharged cycle by cycle via high voltage diode from low-side supply voltage during on-time of the low-side MOSFET. There is an UVLO threshold with hysteresis that enables high-side section at 10.1V and disables it at 8.4V.

**HSGD (High-side Gate drive, Pin 19)**

The Gate of the high-side MOSFET in a half-bridge inverter topology is controlled by this pin. There is an active L-level during UVLO and a

limitation of the max H-level at 11.0 V during normal operation. The switching characteristics are the same as described for LSGD (pin 2). It is recommended to use a resistor of about 10  $\Omega$  between drive pin and Gate in order to avoid oscillations and in order to shift the power dissipation of discharging the Gate capacitance into this resistor. The dead time between LSGD signal and HSGD signal is self adapting between 1.05 $\mu$ s and 2.0 $\mu$ s (typically).

**Not connected (Pin 20)**

This pin is internally not connected.

## 2 Functional Description

### 2.1 Typical Application Circuitry

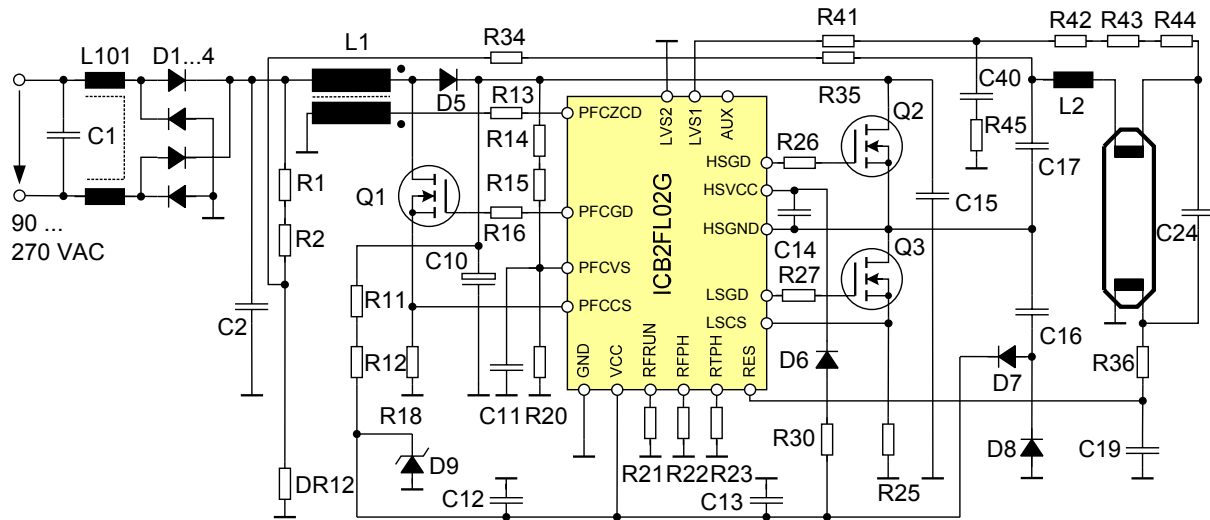

**Figure 3 Application Circuit of Ballast for a single Fluorescent Lamp (FL)**

The schematic in Figure 3 shows a typical application for a T5 single fluorescence lamp. It is designed for universal input voltage from 90 V<sub>AC</sub> until 270 V<sub>AC</sub>. The following chapters are explaining the components and referring to this schematic.

## 2.2 Normal Start Up

This chapter describes the basic operation flow (8 phases) from the UVLO (Under Voltage Lock Out) into Run Mode without any error detection. For detailed information see the following chapters 2.2.1 and 2.2.2. Figure 4 shows the 8 different phases during a typical start from UVLO (phase 1 Figure 4) to Run Mode (phase 8 Figure 4) into normal Operation (no failure detected).

In case the AC line input is switched ON, the  $V_{CC}$  voltage rises to the UVLO threshold  $V_{CC} = 10.6\text{ V}$  (no IC activities during UVLO). If  $V_{CC}$  exceeds the first threshold of  $V_{CC} = 10.6\text{ V}$ , the IC starts the first level of detection activity, the high and low side filament detection during the Start Up Hysteresis (phase 2 Figure 4).

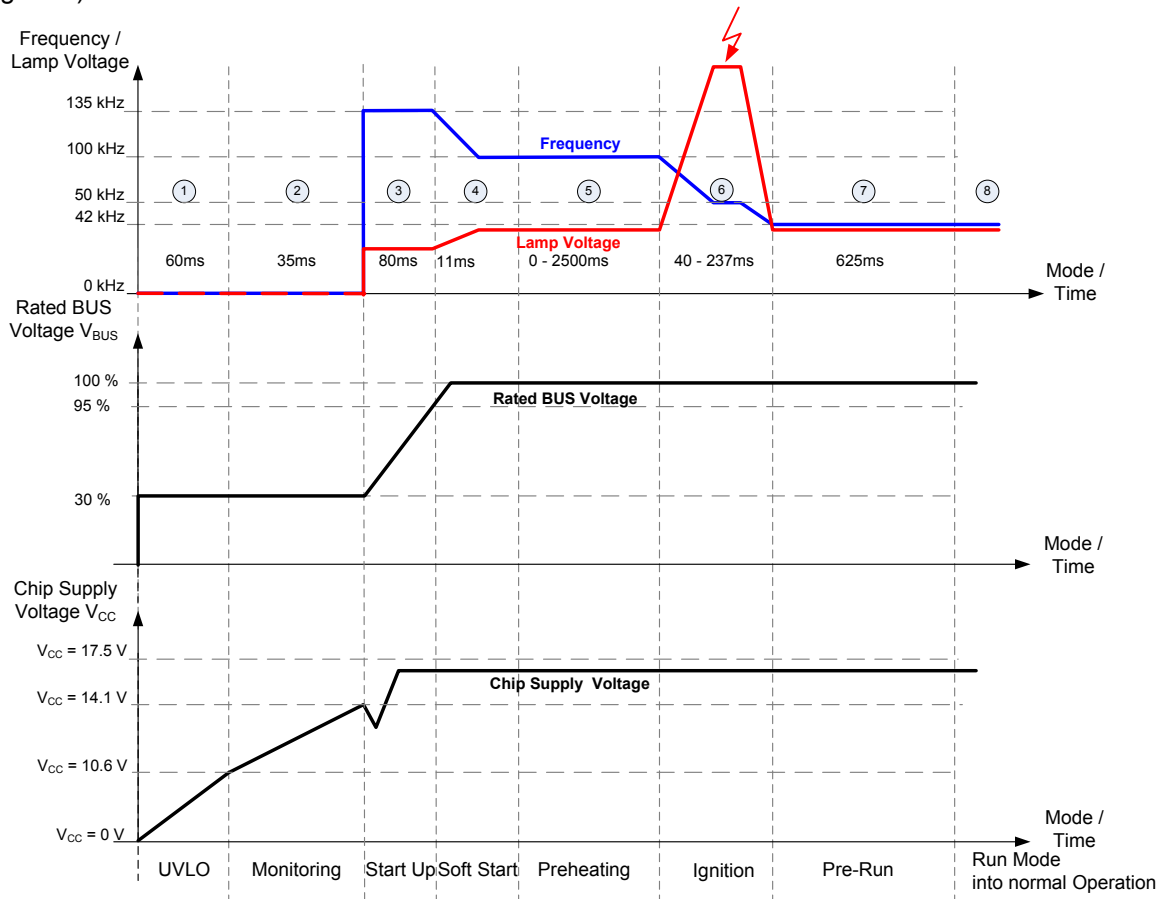

**Figure 4 Typical Start Up Procedure in Run Mode (in normal Operation)**

Followed by the end of the Start Up Hysteresis (phase 2 Figure 4)  $V_{CC} > 14.1\text{ V}$  and before phase 3 is active, a second level of detection activity senses for  $130\text{ }\mu\text{s}$  (propagation delay of the IC) whether the rated bus voltage is below 12.5 % or above 105 %. If the previous bus voltage conditions are fulfilled and the filaments are detected, the IC starts the operation with an internally fixed startup frequency of typically 135 kHz (all gates are active). In case the bus voltage reaches a level of 95% of the rated bus voltage within latest 80ms (phase 3 Figure 4), the IC enters the Soft Start. During the Soft Start (phase 4 Figure 4), the Start Up frequency shifts from 135 kHz down to the set preheating frequency (chapter 2.2.2). In the Soft Start phase, the lamp voltage rises and the chip supply voltage reaches its working level from  $10.6\text{ V} < V_{CC} < 17.5\text{ V}$ . After finish the Soft Start, the IC enters the Preheating mode (phase 5 Figure 4) for preheating the filaments (adjustable time) in order to extend the life cycle of the FL filaments. By finishing the preheating, the controller starts the Ignition (phase 6 Figure 4). During the Ignition phase, the frequency decreases from the set preheating frequency down to the set operation frequency (adjustable see chapter 2.2.2). If the Ignition is successful, the IC enters the Pre – Run mode (phase 7 Figure 4).

This mode is in order to prevent a malfunction of the IC due to an instable system e.g. the lamp parameters are not in a steady state condition. After finish the 625 ms Pre Run phase, the IC switches over to the Run mode (phase 8 Figure 4) with a complete monitoring.

### 2.2.1 Operating Levels from UVLO to Soft Start

This chapter describes the operating flow from phase 1 (UVLO) until phase 4 (Soft Start) in detail. The control of the ballast is able to start the operation within less than 100 ms (IC in active Mode). This is achieved by a small Start Up capacitor (about 1µF C12 and C13 – fed by start up resistors R11 and R12 in Figure 3) and the low current consumption during the UVLO ( $I_{VCC} = 130 \mu A$  – phase 1 Figure 5) and Start Up Hysteresis ( $I_{VCC} = 160 \mu A$  – defines the start up resistors – phase 2 Figure 5) phases. The chip supply stage of the IC is protected against over voltage via an internal Zener clamping network which clamps the voltage at 16.3 V and allows a current of 2.5 mA. For clamping currents above 2.5 mA, an external Zener diode (D9 Figure 3) is required.<sup>1</sup>

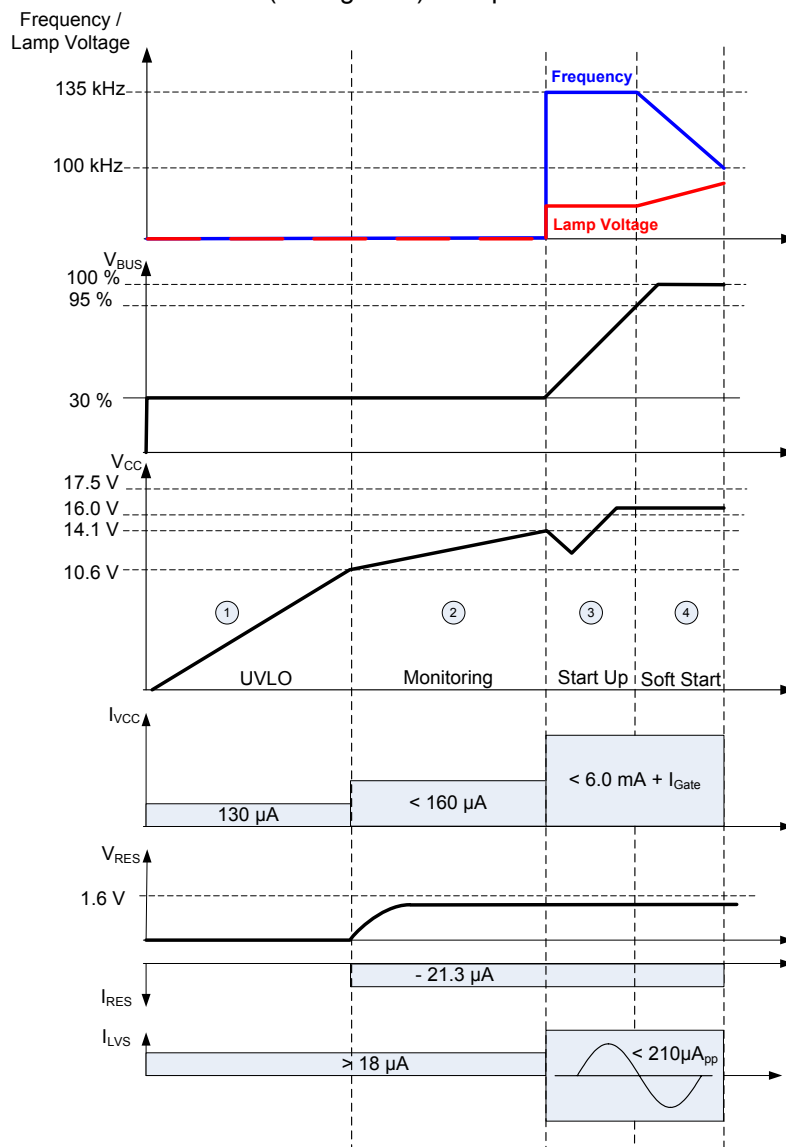

**Figure 5 Progress of Level during a typical Start – UP**

<sup>1</sup> I<sub>Gate</sub> depends on MOSFET

---

**Functional Description**

In case of  $V_{CC}$  exceeds the 10.6 V level and stays below 14.1 V (Start up Hysteresis – phase 2 Figure 5), the IC checks whether the lamps are assembled by detecting a current across the filaments.

The low side filaments are checked from a source current of typical  $I_{RES3} = -21.3 \mu A$  out of PIN 12 RES

(Figure 5  $I_{RES}$ ). This current produces a voltage drop of  $V_{RES} < 1.6 V$  (filament is ok) at the low side filament sense resistor (R 36 in Figure 3), connected to GND (via low side filament). An open low side filament is detected (see chapter 2.3.2), when the voltage at the RES PIN exceeds the  $V_{RES} > 1.6V$  threshold (Figure 5  $V_{RES}$ ).

The high side filaments are checked by a current of  $I_{LVS} > 12 \mu A$  typically via resistors R41, R42, R43 and R44 (Figure 3) into the LVS1 PIN 13 (for a single lamp operation) and LVS2 PIN 14 for a multi lamp operation. Note: in case of a single lamp operation, the unused LVS PIN has to be disabled via connection to GND. An open high side filament is detected (see 2.3.3) when there is no sink current into the LVS PIN. This causes a higher source current out of the RES PIN (typical  $42.6 \mu A / 35.4 \mu A$ ) in order to exceed  $V_{RES} > 1.6 V$ . In case of defect filaments, the IC keeps monitoring until there is an adequate current from the RES or the LVS PIN present (e.g. in case of removal a defect lamp).

When  $V_{CC}$  exceeds the 14.1 V threshold - by the end of the start up hysteresis in phase 2 Figure 5 - the IC waits for 130 $\mu s$  and senses the bus voltage. When the rated bus voltage is in the corridor of  $12.5\% < V_{BUSrated} < 105\%$  the IC powers up the system and enters phase 3 (Figure 5  $V_{BUSrated} > 95\%$  sensing) when not, the IC initiates an UVLO when the chip supply voltage is below  $V_{CC} < 10.6 V$ . As soon as the condition for a power up is fulfilled, the IC starts the inverter gate operation with an internal fixed Start Up frequency of 135 kHz. The PFC gate drive starts with a delay of app. 300 $\mu s$ . Now, the bus voltage will be checked for a rated level above 95 % for a duration of 80 ms (phase 3 Figure 5). When leaving phase 3, the IC enters the Soft Start phase and shifts the frequency from the internal fixed Start Up frequency of 135 kHz down to the set Preheating frequency e.g.  $f_{RFPH} = 100$  kHz.

## 2.2.2 Operating Levels from Soft Start to Run Mode

This chapter describes the operating flow from phase 5 (Preheating mode) until phase 8 (Run mode) in detail. In order to extend the life time of the filaments, the controller enters - after the Soft Start Phase - the Preheating mode (phase 5 Figure 6). The preheating frequency is set by resistors R22 PIN RFPH to GND in combination with R21 (Figure 3) typ. 100 kHz e.g. R22 = 8.2 kΩ in parallel to R21 = 11.0 kΩ see Figure 3 at the R<sub>FRUN</sub> - PIN). The preheating time can be selected by the programming resistor (R23 in Figure 3) at PIN RTPH from 0 ms up to 2500 ms (phase 5 Figure 6).

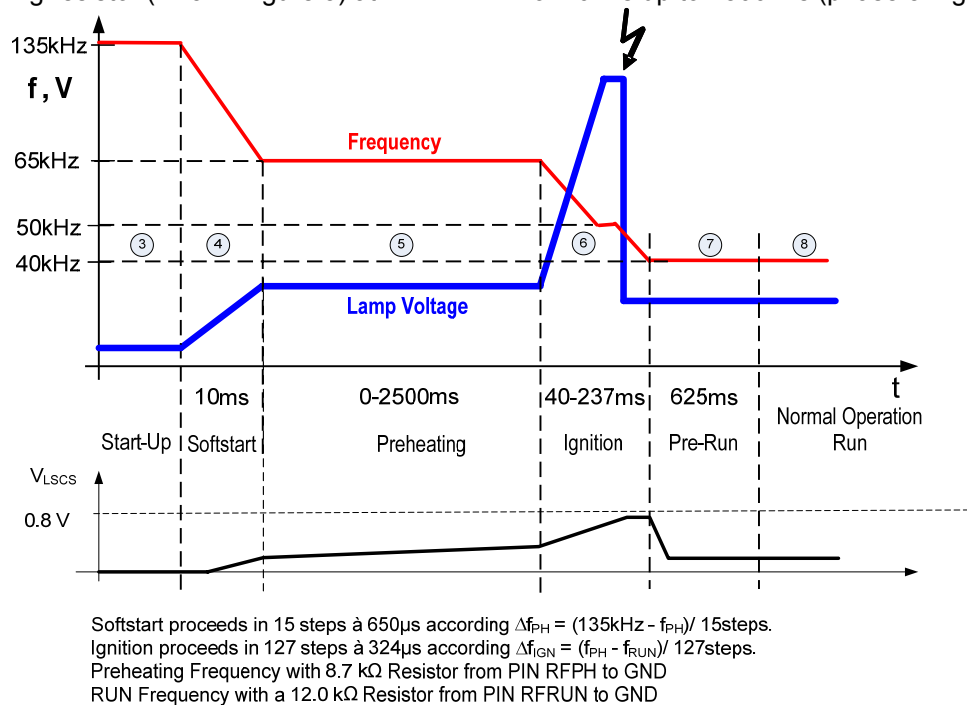

**Figure 6 Typical Variation of Operating Frequency during Start Up**

During Ignition (phase 6 Figure 6), the operating frequency of the inverter is shifted downward in  $t_{typ} = 40\text{ ms}$  ( $t_{max} = 237\text{ ms}$ ) to the run frequency set by a resistor (R21 in Figure 3) at PIN RFRUN to GND (typical 45 kHz with 11.0 kΩ resistor). During this frequency shifting, the voltage and current in the resonant circuit will rise when the operation is close to the resonant frequency with increasing voltage across the lamp. The ignition control is activated if the sensed slope at the LSCS pin reaches typically  $205\text{ mV}/\mu\text{s} \pm 25\text{ mV}/\mu\text{s}$  and exceeds the 0.8V threshold. This stops the decreasing of the frequency and waits for ignition. The ignition control is now continuously monitored by the LSCS PIN. The maximum duration of the Ignition procedure is limited to 237 ms. Is there no Ignition within this time frame, the ignition control is disabled and the IC changes over into the latched fault mode. Furthermore, in order to reduce the lamp choke, the ignition control is designed to operate with a lamp choke in magnetic saturation during ignition. For an operation in magnetic saturation during ignition; the voltage at the shunt at the LSCS pin 1 has to be  $V_{LSCS} = 0.75\text{V}$  when ignition voltage is reached. If the ignition is successful, the IC enters the Pre – Run mode (phase 7 Figure 6). The Pre Run mode is a safety mode in order to prevent a malfunction of the IC due to an instable system e.g. the lamp parameters are not in a steady state condition. After 625 ms Pre Run mode, the IC changes into the Run Mode (phase 8 Figure 6). The Run mode monitors the complete system regarding bus over- and under voltage, open loop, over current of PFC and / or Inverter, lamp over voltage (EOL1) and rectifier effect (EOL2) (see chapter 2.5) and capacitive load 2 (see chapter 2.6).

**Functional Description**

Figure 7 shows the lamp voltage versus the frequency during the different phases from Preheating to the Run Mode. The lamp voltage rises by the end of the Preheating phase with a decreasing frequency (e.g. 100 kHz to 50 kHz) up to 700 V during Ignition. After Ignition, the lamp voltage drops down to its working level with continuo decreasing the frequency (Figure 7) down to its working level e.g. 45 kHz (set by a resistor at the R<sub>FRUN</sub> pin to ground). After stops the decreasing of the frequency, the IC enters the Pre Run mode.

**Lamp Voltage vs Frequency @ different Modes**

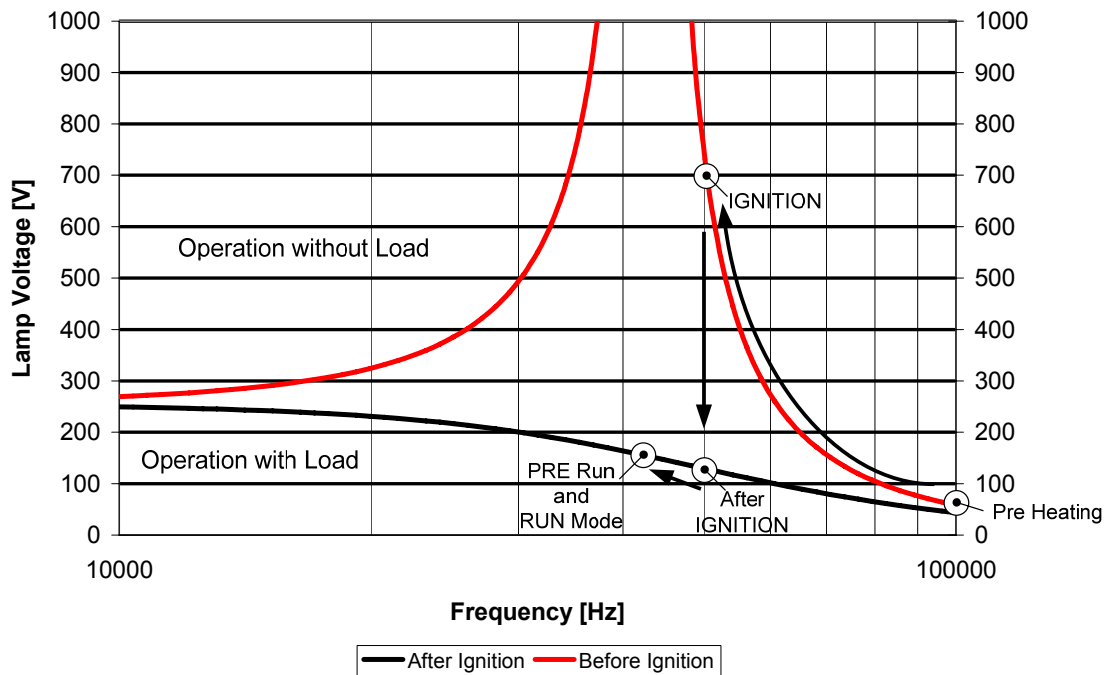

**Figure 7 Lamp Voltage versus Frequency during the different Start up Phases**



## 2.3 Filament Detection during Start Up and Run Mode

The low and high side filament detection is sensed via the RES and the LVS pins. The low side filament detection during start up and run mode is detected via the RES pin only. An open high side filament during start up will be sensed via the LVS and the RES pins.

### 2.3.1 Start Up with broken Low Side Filament

A source current of  $I_{RES3} = - 21.3 \mu A$  out of the RES pin (12) monitors during a start up (also in Run mode) the existence of a low side filament. In case of an open low side filament during the start up hysteresis ( $10.6V < V_{CC} < 14.1V$ ) a capacitor (C19 in Figure 3) will be charged up via  $I_{RES3} = - 21.3 \mu A$ . When the voltage at the RES pin (12) exceeds  $V_{RES1} = 1.6 V$ , the controller prevents a power up and clamps the RES voltage internally at  $V_{RES} = 5.0 V$ . The gate drives of the PFC and inverter stage do not start working.

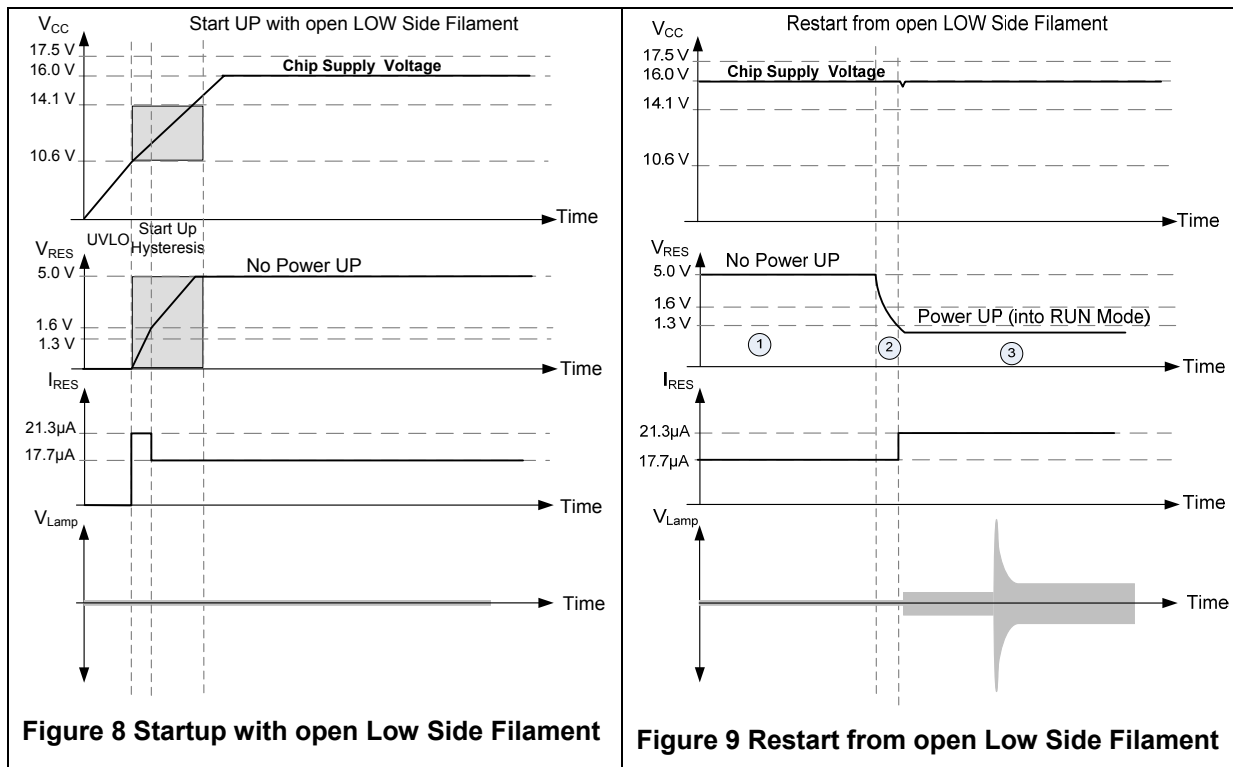

The IC comparators are set now to a threshold of  $V_{RES1} = 1.3V$  and to  $I_{RES4} = - 17.7 \mu A$ , the controller waits until the voltage at the RES pin drops below  $V_{RES1} = 1.3V$ . When a filament is present (Figure 9 section 2), the voltage drops below  $1.3V$  and the value of the source current out of the RES pin is set from  $I_{RES4} = - 17.7 \mu A$  up to  $I_{RES3} = - 21.3 \mu A$ . Now the controller powers up the system including Soft Start and Preheating into the Run mode.

### 2.3.2 Low Side Filament Detection during Run Mode

In case of an open low side filament during Run mode, the current out of the RES pin  $I_{RES3} = -21.3 \mu A$  charges up the capacitor C19 in Figure 3. If the voltage at the RES pin exceeds the  $V_{RES3} = 3.2V$  threshold, the controller detects an open low side filament and stops the gate drives after a delay of  $t = 620 \mu s$  of an internal timer.

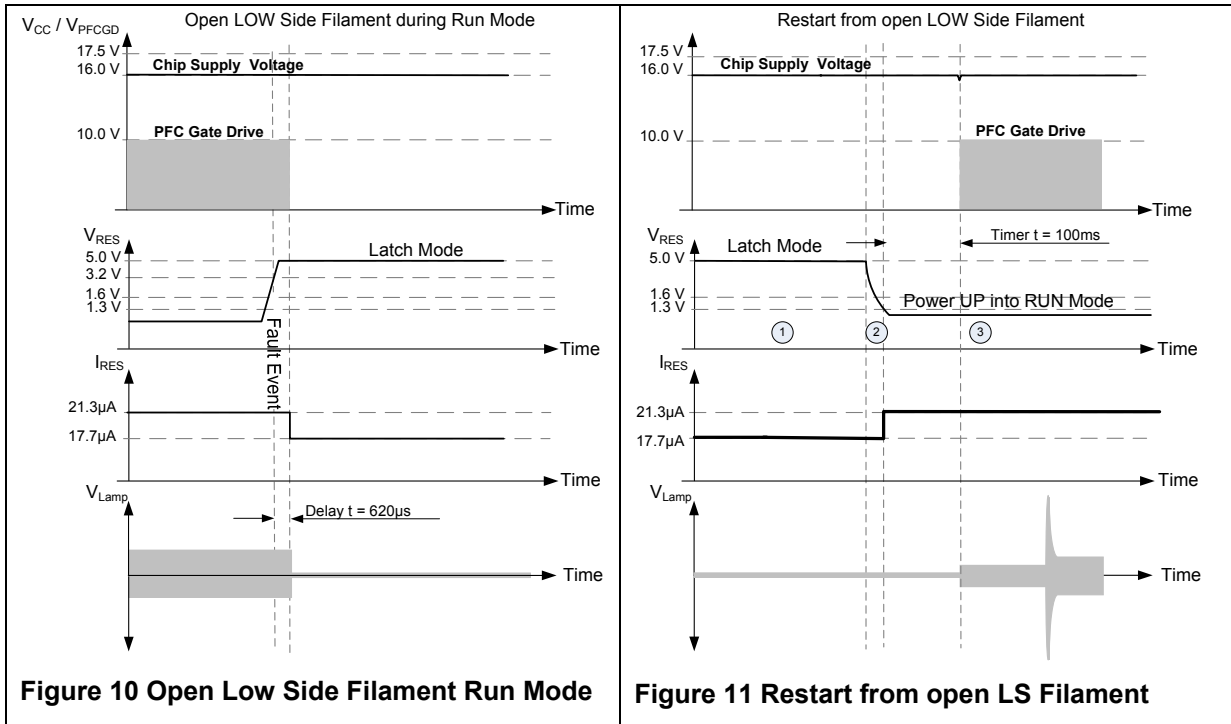

A restart is initiated when a filament is detected e.g. in case of a lamp removal. In case of a filament is present (Figure 11 section 2), the voltage drops below 1.3V and the value of the source current out of the RES pin is set from  $I_{RES4} = -17.7 \mu A$  up to  $I_{RES3} = -21.3 \mu A$ . The controller powers up the system including Soft Start and Preheating into the Run mode (Figure 11 section 3).

### 2.3.3 Start Up with broken High Side Filament

An open high side filament during the start up hysteresis ( $10.6V < V_{CC} < 14.1V$ ) is detected, when the current into the LVS pin 13 or 14 is below  $I_{LVS} = 12 \mu A$  (typically). In that case, the current out of the RES pin 12 rises up to  $I_{RES1} = -42.6 \mu A$ . That causes a voltage at the RES pin crosses  $V_{RES1} = 1.6V$ . The source current is now set to  $I_{RES2} = -35.4 \mu A$  and another threshold of  $V_{RES2} = 1.3V$  is active. The controller prevents a power up (see Figure 12), the gate drives of the PFC and inverter stage do not start working.

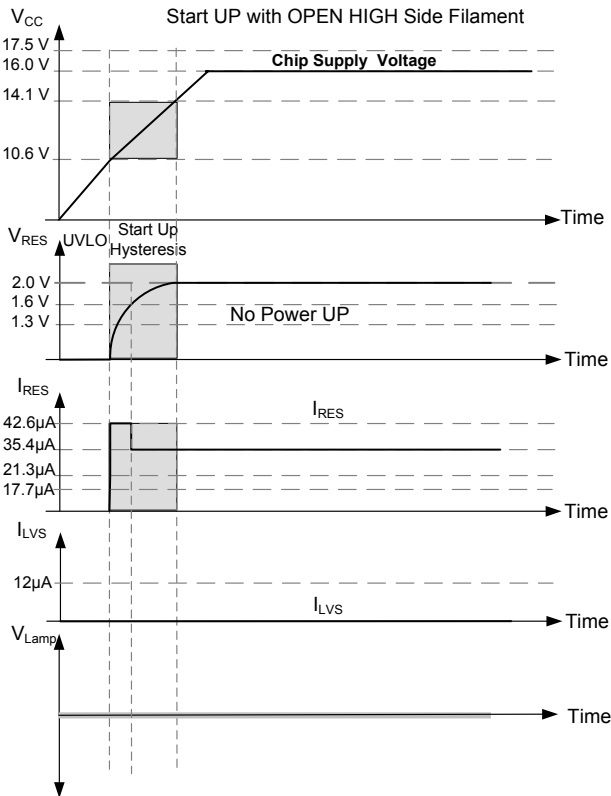

Figure 12 Start Up with open high Side Filament

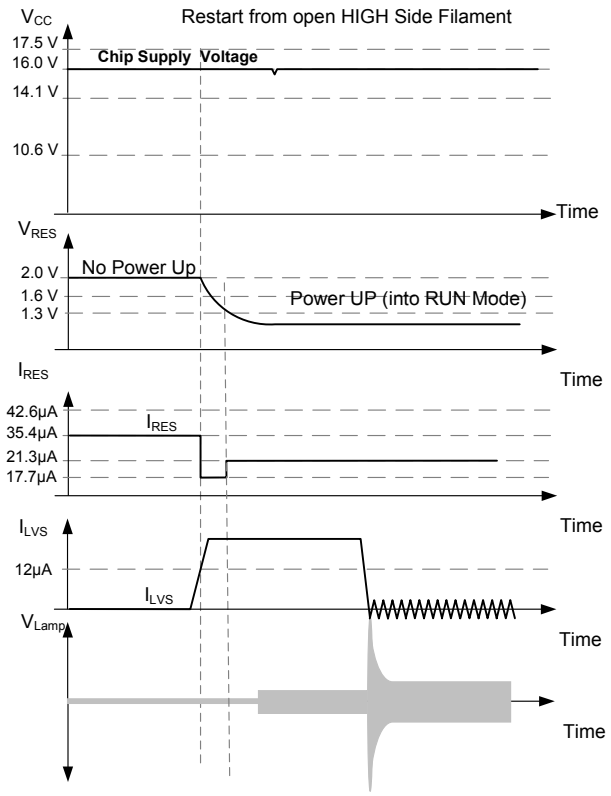

Figure 13 Restart from open high Side Filament

When the high side filament is present, e.g. insert a lamp, the current of the active LVS pins exceeds  $I_{LVS} > 12 \mu A$  (typically), the res current drops from  $I_{RES2} = -35.4 \mu A$  down to  $I_{RES4} = -17.7 \mu A$  (Figure 13). Now the controller senses the low side filament. When a low side filament is also present, and the controller drops (after a short delay due to a capacitor at the res pin) below  $V_{RES2} = 1.3V$ , the res current is set to  $I_{RES3} = -21.3 \mu A$ , the controller powers up the system.

Functional Description

2.4 PFC Pre Converter

2.4.1 Discontinuous Conduction and Critical Conduction Mode Operation

The digital controlled PFC pre converter starts with an internally fixed ON time of typical  $t_{ON} = 4.0\mu s$  and variable frequency. The ON – time is enlarged every 280  $\mu s$  (typical) up to a maximum ON – time of 22.7  $\mu s$ . The control switches quite immediately from the discontinuous conduction mode (DCM) over into critical conduction mode (CritCM) as soon as a sufficient ZCD signal is available. The frequency range in CritCM is 22 kHz until 500 kHz, depending on the power (Figure 14) with a variation of the ON time from 22.7  $\mu s > t_{ON} > 0.5\mu s$ .

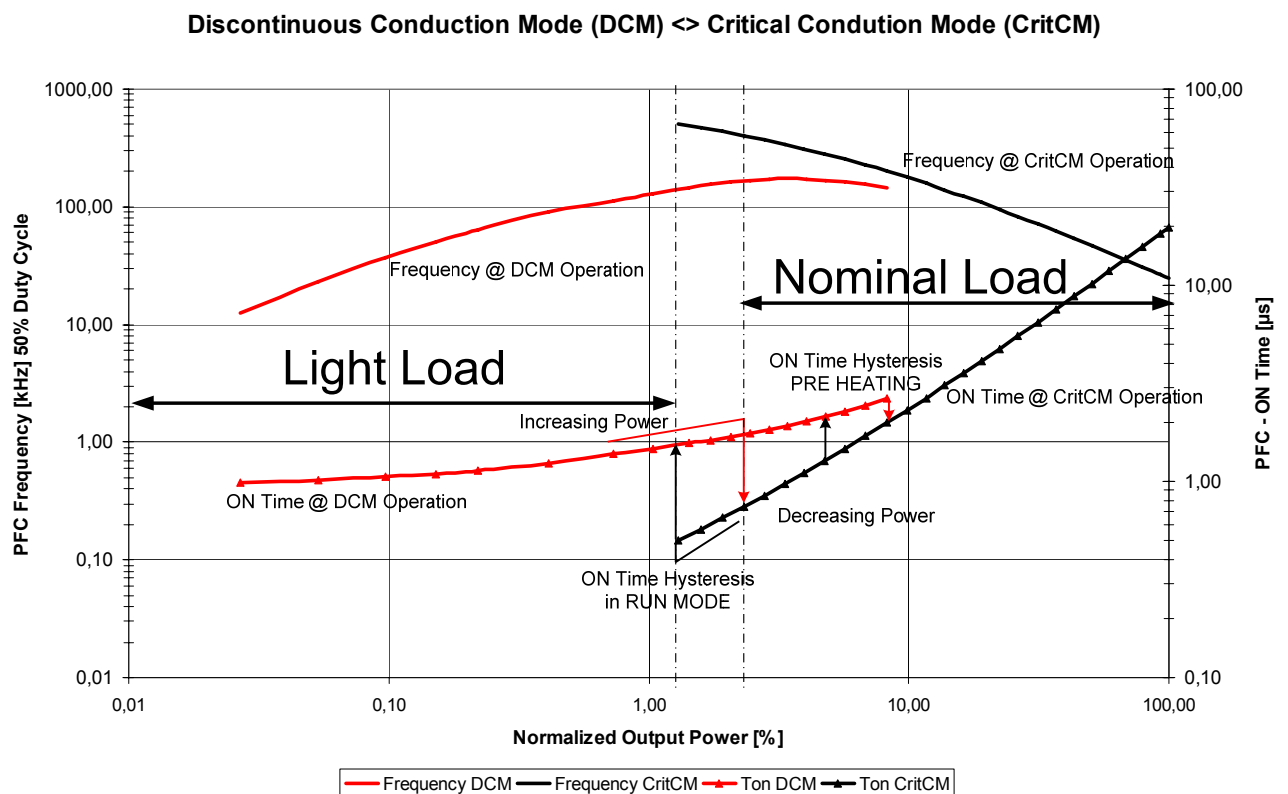

**Figure 14 Operating Frequency and ON Time versus Power in DCM and CritCM Operation**

For lower loads ( $P_{OUTNorm} < 8\%$  from the normalized load<sup>2</sup>) the control operates in discontinuous conduction mode (DCM) with an ON – time from 4.0 $\mu s$  and increasing OFF – time. The frequency during DCM is variable in a range from 144 kHz down to typically 22 kHz @ 0.1 % Load (Figure 14). With this control method, the PFC converter enables a stable operation from 100 % load down to 0.1 %. Figure 14 shows the ON time range in DCM and CritCM (Critical Conduction Mode) operation. In the overlapping area of CritCM and DCM is a hysteresis of the ON time which causes a negligible frequency change.

<sup>2</sup> Normalized Power @ Low Line Input Voltage and maximum Load

### 2.4.2 PFC Bus Voltage Sensing

Over voltage, open loop, bus 95 % and under voltage states (Figure 15) of the PFC bus voltage are sensed at the PFCVS pin via the network R14, R15, R20 and C11 Figure 3 (C11 acts as a spike suppression filter).

#### 2.4.2.1 Bus Over Voltage and PFC Open Loop

The bus voltage loop control is completely integrated (Figure 16) and provided by an 8 Bit sigma – delta A/D – converter with a typical sampling rate of 280  $\mu$ s and a resolution of 4 mV/Bit. After leaving phase 2 (monitoring), the IC starts the power up ( $V_{CC} > 14.1V$ ). After power up, the IC senses for 130 $\mu$ s the bus voltage below 12.5% (open loop) or above 105% (bus over voltage). In case of a bus over voltage ( $V_{BUSrated} > 109\%$ ) or open loop ( $V_{BUSrated} < 12.5\%$ ) in phases 3 until 8 the IC shuts off the gate drives of the PFC within 5 $\mu$ s respective in 1 $\mu$ s. In this case, the PFC restarts automatically when the bus voltage is within the corridor ( $12.5\% < V_{BUSrated} < 105\%$ ) again. Is the bus voltage after the 130 $\mu$ s valid, the bus voltage sensing is set to  $12.5\% < V_{BUSrated} < 109\%$ . In case leaving these thresholds for longer than 1 $\mu$ s (open loop) or 5 $\mu$ s (overvoltage) the PFC gate drive stops working until the voltage drops below 105% or exceeds the 12.5% level. If the bus over voltage (>109%) lasts for longer than 625ms in run mode, the inverter gates also shut off and a power down with complete restart is attempt (Figure 15).

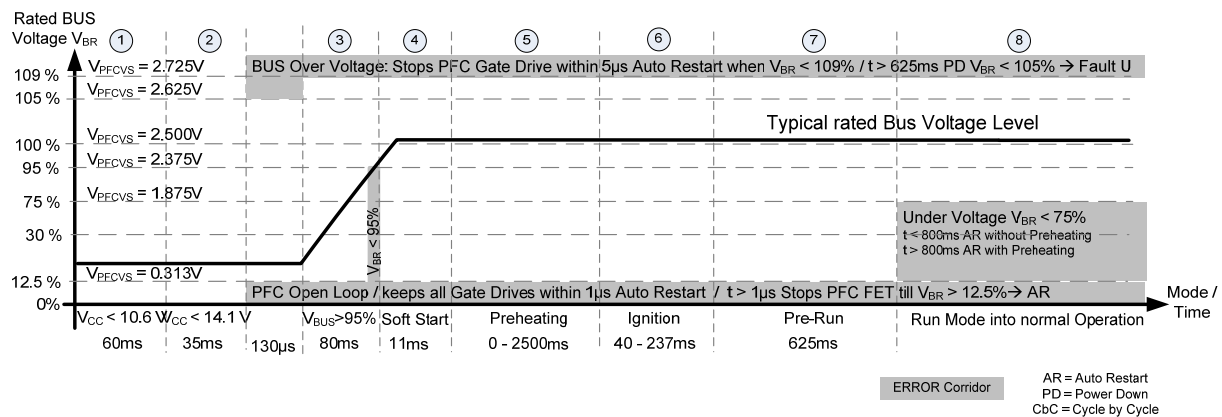

Figure 15 PFC Bus Voltage Operating Level and Error Detection

#### 2.4.2.2 Bus Voltage 95% and 75% Sensing

When the rated bus voltage is in the corridor of  $12.5\% < V_{BUSrated} < 109\%$ , the IC will check whether the bus voltage exceeds the 95 % threshold (Figure 15 phase 3) within 80 ms before entering the soft start phase 4. Another threshold is activated when the IC enters the run mode (phase 8). When the rated bus voltage drops below 75% for longer than 84  $\mu$ s, a power down with a complete restart is attempted when a counter exceeds 800 ms. In case of a short term bus under voltage (the bus voltage reaches its working level in run mode before exceeding typically 800 ms (min. 500ms) the IC skips phases 1 until 5 and starts with ignition (condition for emergency lighting see 2.7.1). The internal reference level of the bus voltage sense  $V_{PFCVS}$  is 2.5 V (100 % of the rated bus voltage) with a high accuracy. A surge protection is activated in case of a rated bus voltage of  $V_{BUS} > 109\%$  and a low side current sense voltage of  $V_{LSCS} > 0.8V$  for longer as 500ns in PRE RUN and RUN Mode.

### 2.4.3 PFC Structure of Mixed Signal

A digital NOTCH filter eliminates the input voltage ripple - independent from the mains frequency. A subsequent error amplifier with PI characteristic cares for a stable operation of the PFC pre converter (Figure 16).

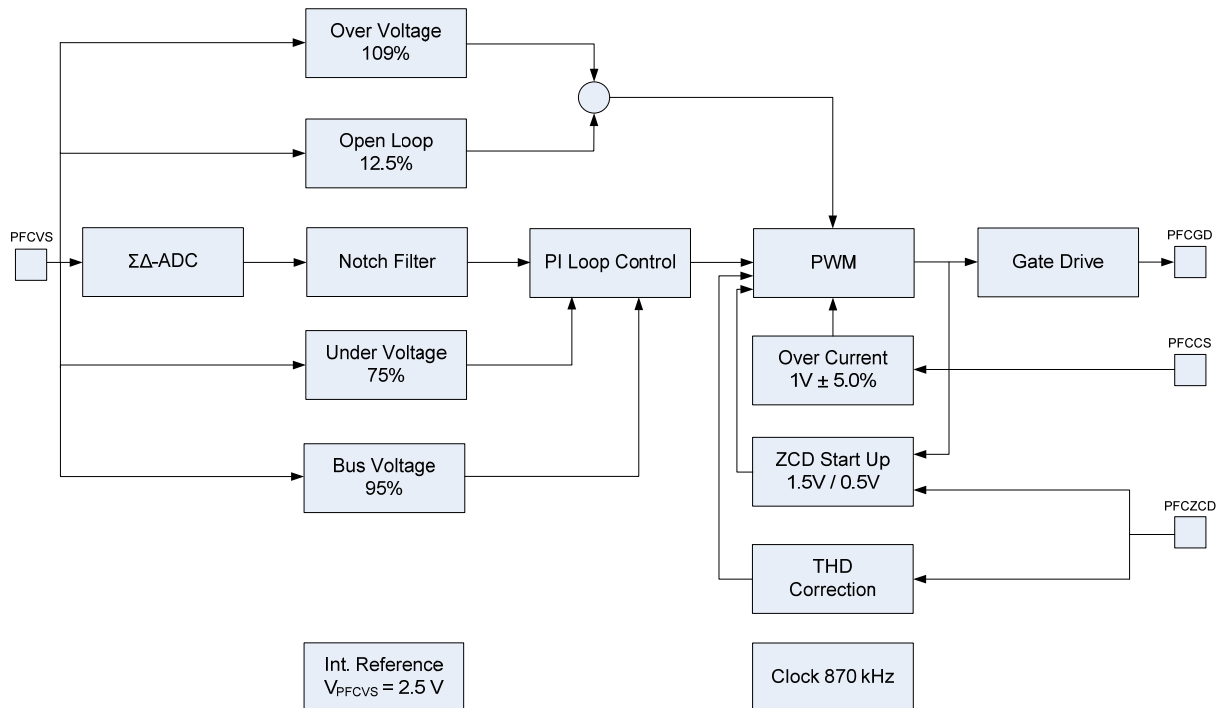
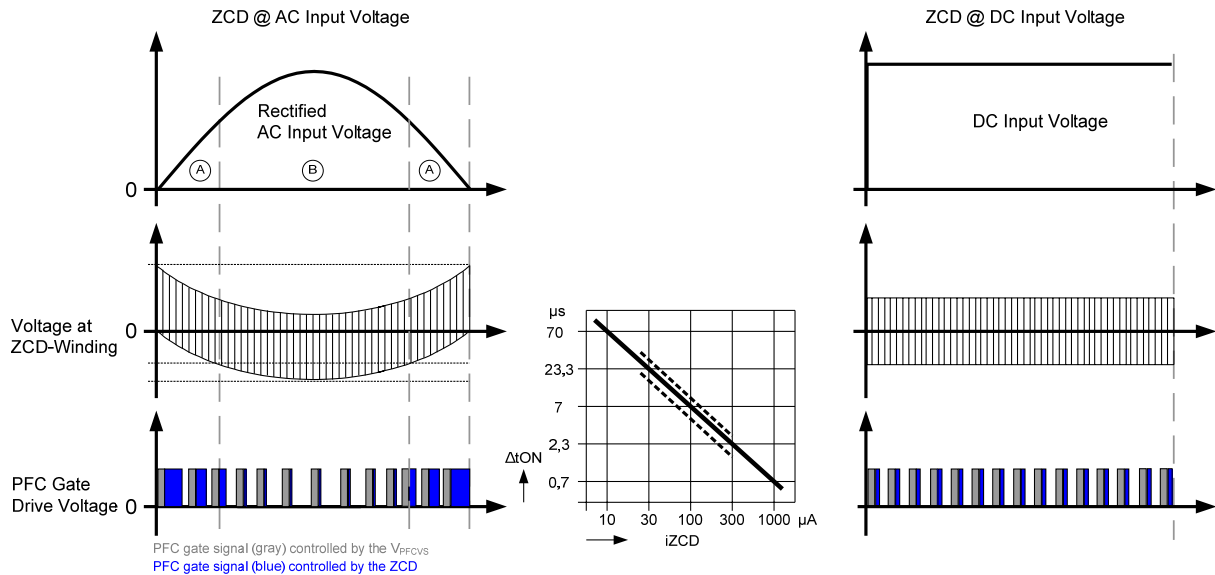

**Figure 16 Structure of the mixed digital and analog control of the PFC pre converter**

The zero current detection (ZCD) is sensed by the PFCZCD pin via R13 (Figure 3). The information of finished current flow during demagnetization is required in CritCM and in DCM as well. The input is equipped with a special filtering including a blanking of typically 500 ns and a large hysteresis of typically 0.5 V and 1.5 V  $V_{PFCZCD}$  (Figure 16).

### 2.4.4 THD Correction via ZCD Signal

An additional feature is the THD correction (Figure 16). In order to optimize the improved THD (especially in the zones A shown in Figure 17 ZCD @ AC Input Voltage), there is a possibility to extend pulse width of the gate signal (blue part of the PFC gate signal in Figure 17) via variable PFC ZCD resistor (see Resistor R13 in Figure 3) in addition to the gate signal controlled by the  $V_{PFCVS}$  signal (gray part of the PFC gate signal in Figure 17).



**Figure 17 THD Optimization using adjustable Pulse Width Extension**

In case of DC input voltage (see DC Input Voltage in Figure 17), the pulse width gate signal is fixed as a combination of the gate signal controlled by the  $V_{PFCVS}$  pin (gray) and the additional pulse width signal controlled by the ZCD pin (blue) shown in Figure 17 ZCD @ DC Input Voltage. The PFC current limitation at pin PFCCS interrupts the ON – time of the PFC MOSFET if the voltage drop at the shunt resistors R18 (Figure 3) exceeds the  $V_{PFCCS} = 1.0\text{ V}$  (Figure 16). This interrupt will restart after the next sufficient signal from ZCD is available (Auto Restart). The first value of the resistor can be calculated by the ratio of the PFC mains choke and ZCD winding the bus voltage and a current of typically 1.5 mA (see equation below). An adjustment of the ZCD resistor causes an optimized THD.

$$R_{ZCD} = \frac{N_{ZCD} * V_{BUS}}{N_{PFC} * 1.5mA}$$

**Equation 1  $R_{ZCD}$  a good practical Value**

### 2.4.5 Optional THD Correction dedicated for DCM Operation

For applications with a wide input voltage range and / or for applications using a wide variation of the power e.g. dimming, the application might work in the DCM (Discontinuous Conduction Mode). In order to minimize the high order harmonics during DCM, the detection of the DCM should be as close as possible at the point of inflection of the PFC drain source voltage shown in Figure 18.

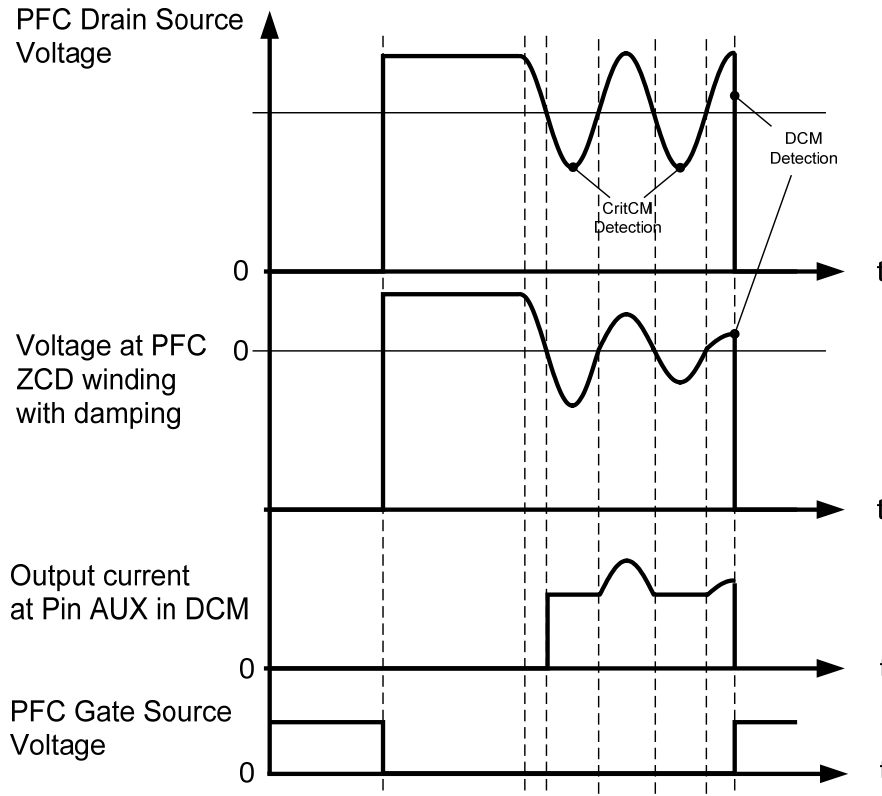

**Figure 18 Signal Shapes with optional damping of oscillations during DCM operation of PFC.**

This can be realized with an optional damping network (R4, D10 and Q4 see Figure 19) from the AUX pin to the ZCD resistor R13.

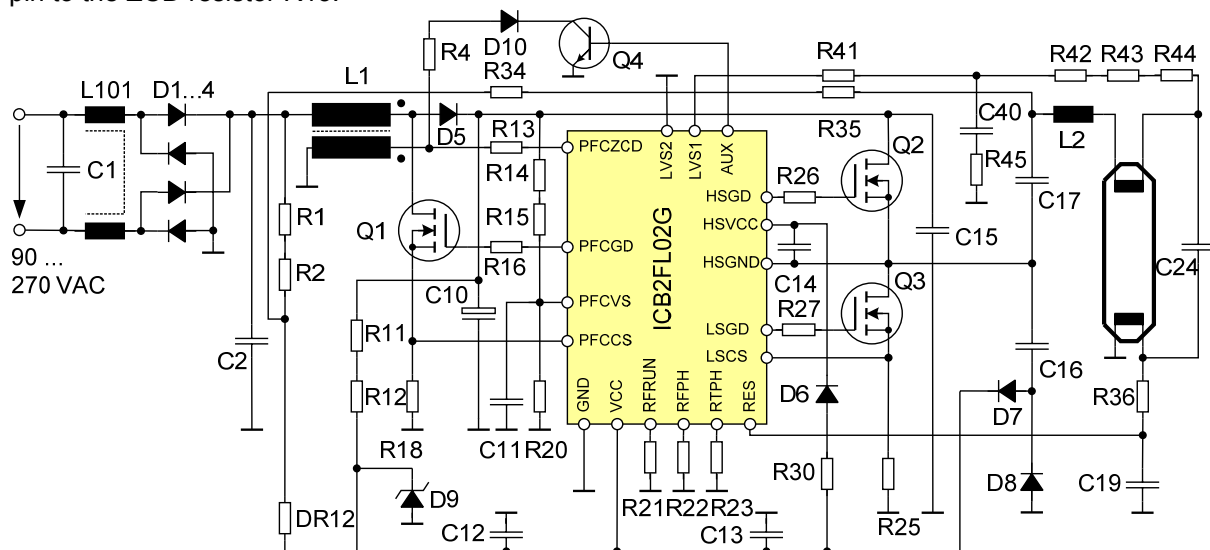

**Figure 19 Optional Circuit for attenuating oscillations during DCM operation of PFC**



## 2.5 Detection of End-of-Life and Rectifier Effect

Two effects are present by End of Life (EOL): lamp over voltage (EOL1) and a rectifier effect (EOL2). After Ignition (see 1 in Figure 20), the lamp voltage breaks down to its run voltage level with decreasing frequency. By reaching the run frequency, the IC enters the Pre Run Mode for 625 ms. During this period, the EOL detection is still disabled. In the subsequent RUN Mode (2 in Figure 20) the detection of EOL1 (lamp over voltage see 3 Figure 20) and EOL2 (rectifier effect see 4 Figure 20) is complete enabled.

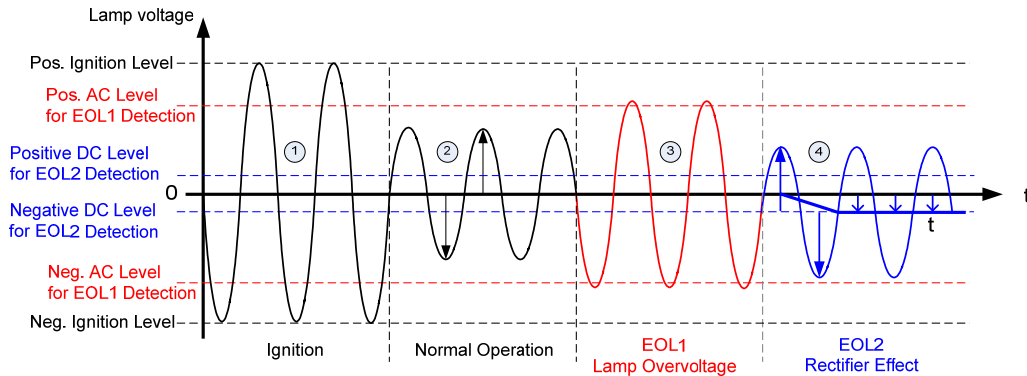

Figure 20 End of Life and Rectifier Effect

### 2.5.1 Detection of End of Life 1 (EOL1) – Lamp Overvoltage

The event of EOL1 is detected by measuring the positive and negative peak level of the lamp voltage via an AC current fed into the LVS pin (Figure 21). This AC current is fed into the LVS pins (LVS1 for single lamp and LVS2 for multi lamp applications) via Network R41, R42, R43, R44 and the low pass filter C40 and R45 see Figure 3. If the sensed AC current exceeds  $210 \mu A_{PP}$  for longer than  $620 \mu s$ , the status of end-of-life (EOL1) is detected (lamp overvoltage / overload see Figure 21 LVSAC Current). The EOL1 fault results in a latched power down mode (after trying a single restart) the controller is continuously monitoring the status until EOL1 status changes e.g. a new lamp is inserted.

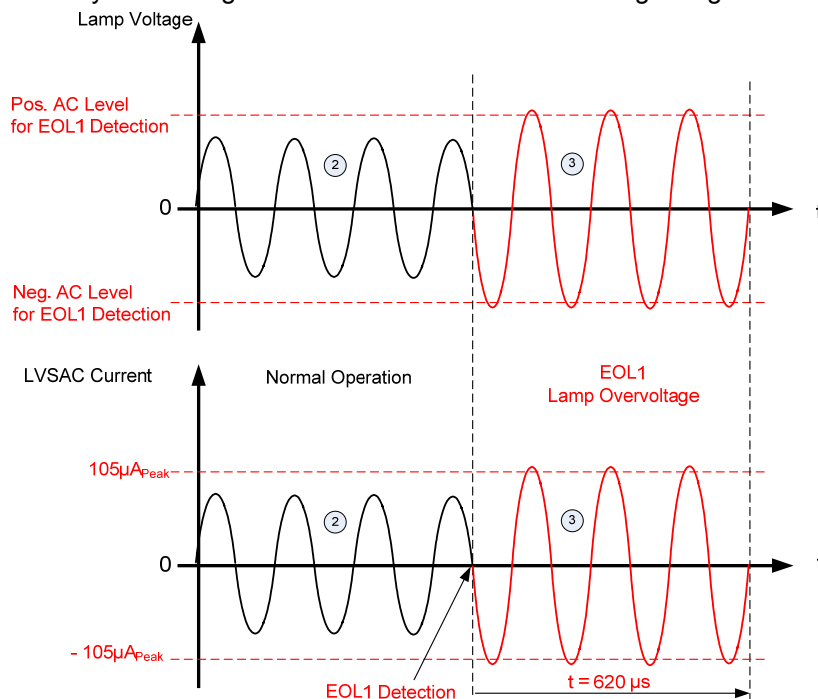

Figure 21 End of Life (EOL1) Detection, Lamp Voltage versus AC LVS Current

### 2.5.2 Detection of End of Life 2 (EOL2) – Rectifier Effect

The rectifier effect (EOL2) is detected by measuring the positive and negative DC level of the lamp voltage via a current fed into the LVS pin (Figure 22). This current is fed into the LVS pins (LVS1 for single lamp and LVS2 for multi lamp applications) via Network R41, R42, R43 and R44 (see Figure 3). If the sensed DC current exceeds  $\pm 42 \mu\text{A}$  (Figure 22 LVSDC Current) for longer than 2500 ms, the status of end-of-life (EOL2) is detected. The EOL2 fault results in a latched power down mode (after trying a single restart) the controller is continuously monitoring. The insert of a new lamp or the interruption of the input voltage resets the status of the IC.

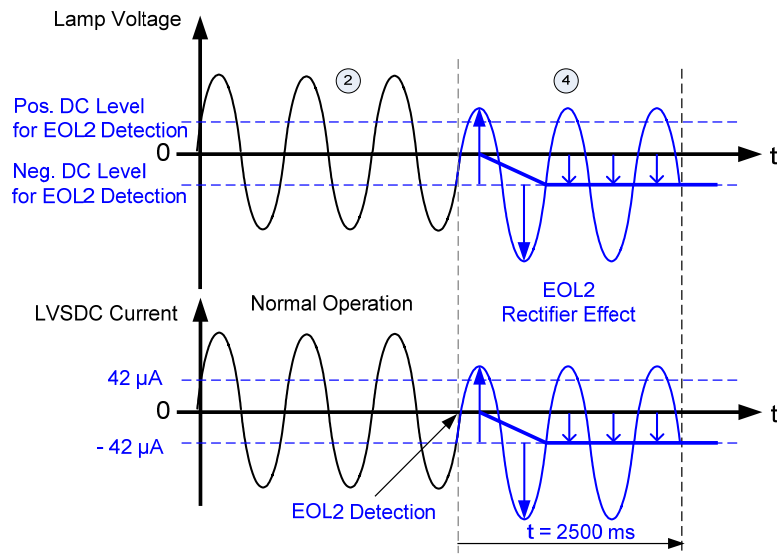

Figure 22 End of Life (EOL2) Detection, Lamp Voltage versus DC LVS Current

## 2.6 Detection of Capacitive Load

In order to prevent a malfunction in the area of Capacitive Load (see Figure 23) during Run Mode due to certain deviations from the normal load (e.g. harmed lamp, sudden break of the lamp tube ...), the IC has two integrated thresholds – sensed only via the LSCS (pin 1). The controller detects working with short over current (CapLoad 2). This state (CapLoad 2) is affecting an operation below the resonance in the capacitive load area (Figure 23). In this case the IC results in a latched power down mode after a single restart. After latching the power down mode, the controller is continuously monitoring the input voltage and lamp filaments and restarts after interrupting the input voltage or inserting a new lamp.

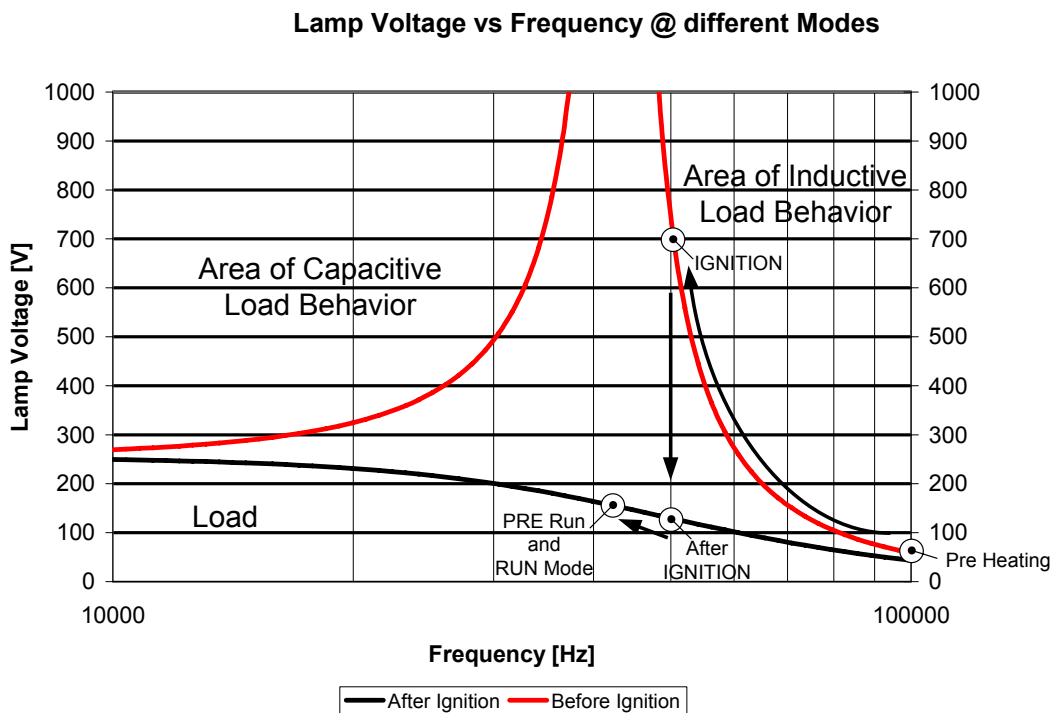

Figure 23 Capacitive and Inductive Operation

### 2.6.1 Capacitive Load 2 (Over Current / Operation below Resonance)

A capacitive load 2 operation is detected if the voltage at the LSCS pin drops below a second threshold of  $V_{LSCS} = -50\text{ mV}$  directly before the high side MOSFET is turned on or exceeds a third threshold of  $V_{LSCS} = 2.0\text{ V}$  during ON switching of the high side MOSFET. If this over current is present for longer than  $620\text{ }\mu\text{s}$ , the IC results a latched power down mode after trying a single restart. The controller keeps monitoring continuously the status until an adequate load is present e.g. a new lamp is inserted, then the IC changes into a normal operation.

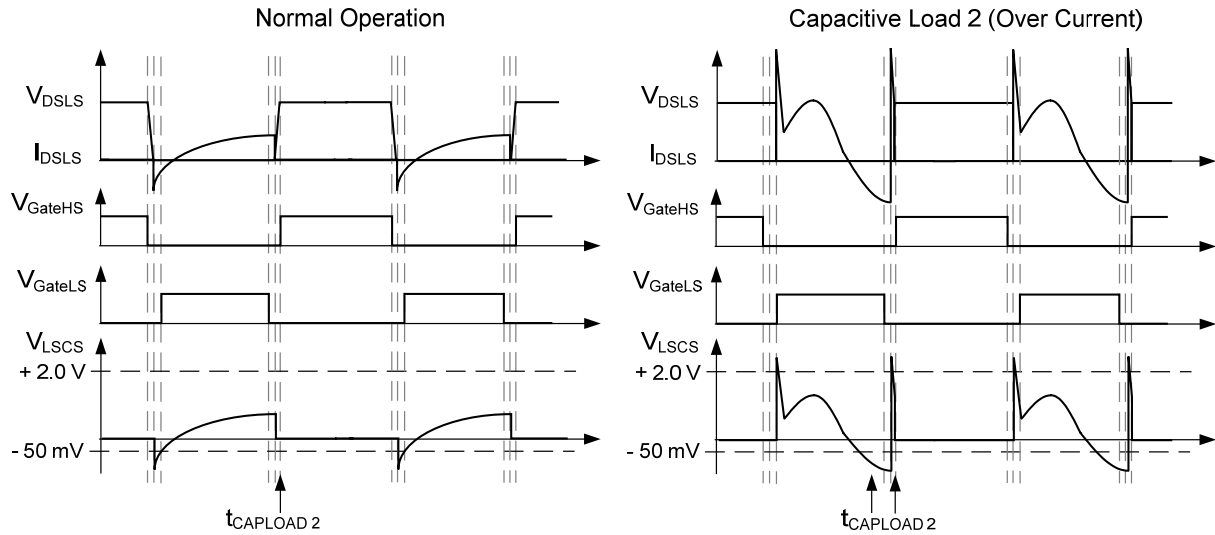

Figure 24 Capacitive Mode 2 – Operation with Over Current

### 2.6.2 Adjustable self adapting Dead Time

The dead time between the turn OFF and turn ON of the half – bridge drivers is adjustable (C16 see Figure 3) and detected via a second threshold ( $-50\text{ mV}$ ) of the LSCS voltage. The range of the dead time adjustment is  $1.05\text{ }\mu\text{s}$  up to  $2.0\text{ }\mu\text{s}$  during all operating modes. Start of the dead time measurement is the OFF switching of the high side MOSFET. The finish of the dead time measurement is, when  $V_{LSCS}$  drops for longer than typical  $280\text{ ns}$  (internal fixed propagation delay) below  $-50\text{ mV}$ . This time will be stored (stored dead time) and the low side gate driver switches ON. The high side gate driver turns ON again after OFF switching of the low side switch and the stored dead time.

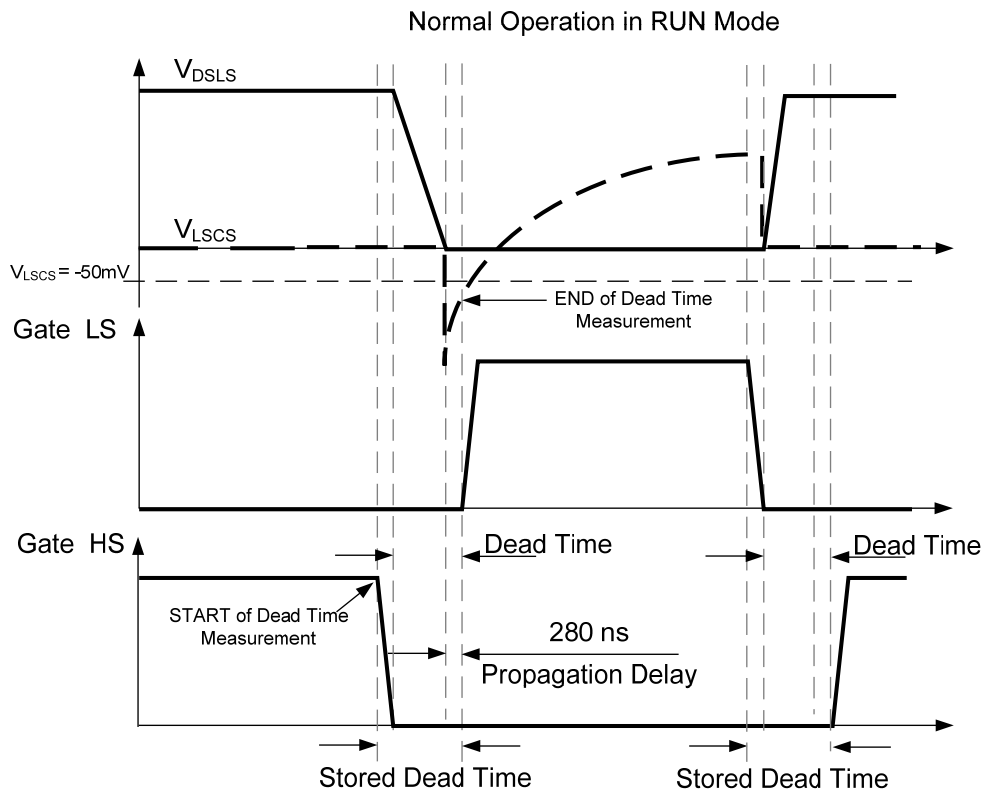

Figure 25 Dead Time of ON and OFF of the Half Bridge Drivers

## 2.7 Emergency Lighting

Line interruptions (bus voltage drops) are detected by the PFCVS. If the rated PFC bus voltage drops below  $V_{BUSRated} < 75\%$  during run mode, the controller detects a PFC bus under voltage. In order to meet the emergency lighting standards, the controller distinguishes two different states of a PFC bus under voltage, a short and a long term PFC bus under voltage. A timer increases the time as long as a bus under voltage is present. A short term bus under voltage is detected if the timer value stays below  $t < 800\text{ms}$  typically (500ms min.) after the bus voltage reaches the nominal level again. This causes a restart without preheating (emergency standard of VDE0108) see Figure 26. When the timer exceeds  $t > 800\text{ms}$ , the controller forces a complete restart of the system due to a long term bus under voltage (Figure 27).

### 2.7.1 Short Term PFC Bus Under Voltage

A short term PFC bus under voltage (Figure 26) is detected if the duration of the under voltage does not exceed 800 ms (timer stays below  $t < 800\text{ms}$  see Figure 26). In that case, the PFC and inverter drivers are immediately switched off and the controller is continuously monitoring the status of the bus voltage in a latched power down mode ( $I_{CC} < 170 \mu\text{A}$ ). If the signal at the LVS PIN exceeds  $18\mu\text{A}$  and the rated bus voltage is above 12.5% within the timer is below  $t < 800 \text{ms}$ , the controller restarts from power up without preheating. The timer resets to 0 when entering the Run Mode.

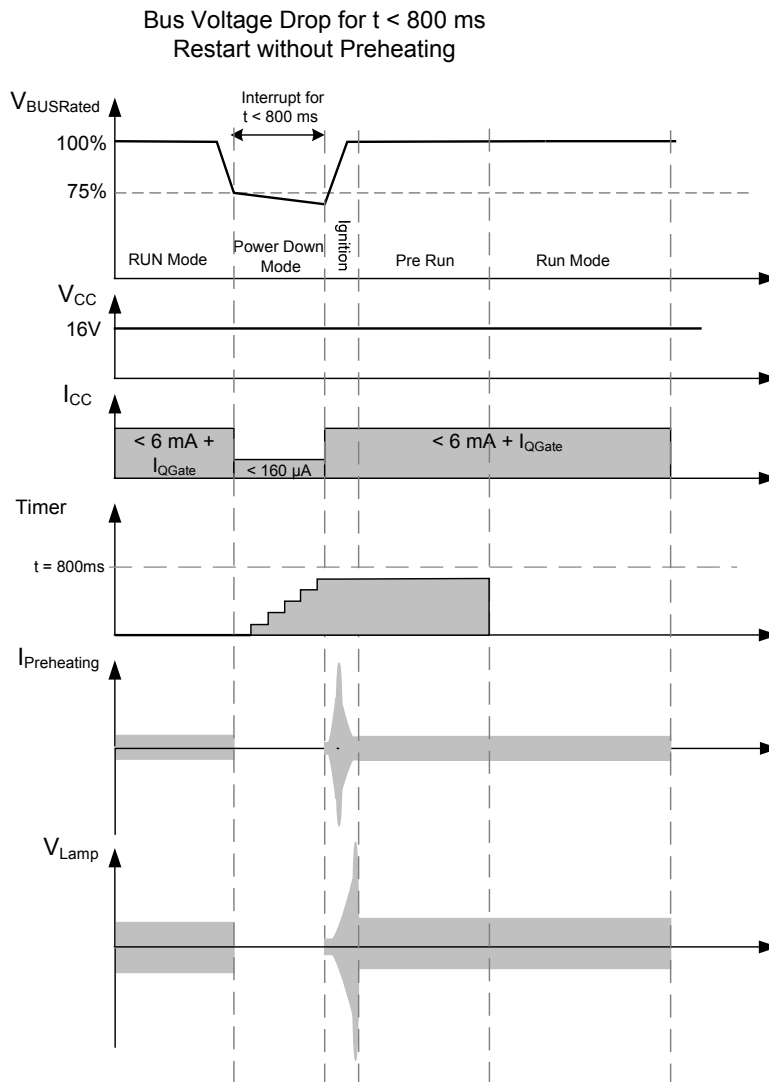

Figure 26 BUS Voltage Drop below 75% (rated Bus Voltage) for  $t < 800 \text{ms}$  during RUN Mode

### 2.7.2 Long Term PFC Bus Under Voltage

If the duration of the bus under voltage exceeds  $t > 800\text{ms}$  see Figure 27, the controller forces an under voltage lock out (UVLO). The chip supply voltage drops below  $V_{CC} = 10.6\text{V}$  and the chip supply current is below  $I_{CC} < 130\mu\text{A}$ . When the  $V_{CC}$  voltage exceeds the  $10.6\text{V}$  threshold again, the IC current consumption is below  $I_{CC} < 160\mu\text{A}$ . In that case, the controller resets the timer and restarts with the full start up procedure including Monitoring, Power Up, Start Up, Soft Start, Preheating, Ignition, Pre Run and Run Mode as shown in Figure 27.

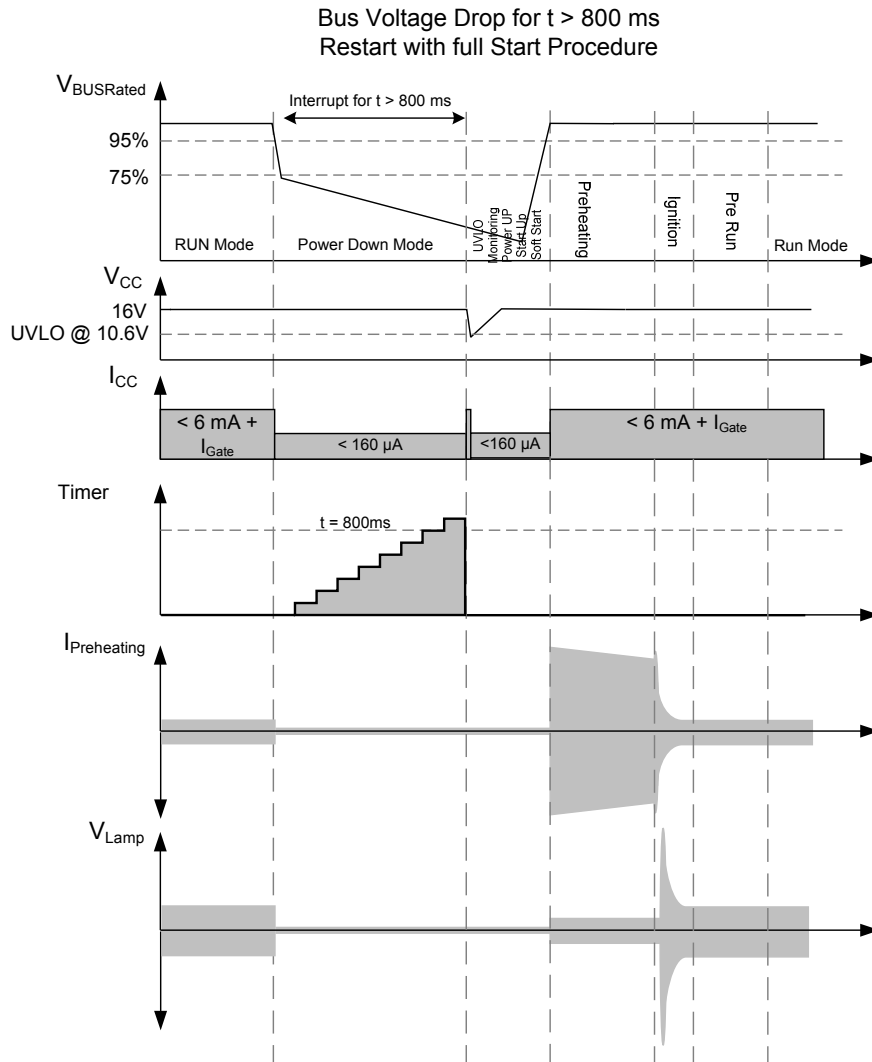

Figure 27 BUS Voltage Drop below 75% (rated Bus Voltage) for  $t > 800\text{ms}$  during RUN Mode



## 2.8 Built in Customer Test Mode Operation

In order to decrease the final ballast testing time for customers, the 2<sup>nd</sup> generation of ballast IC supports an integrated built in Customer Test Mode and several functions to disable some features and states of the IC.

### 2.8.1 Pre Heating Test Mode

This feature forces the IC to stay in the pre heating mode (see chapter 2.8.1.2) or to starts the ignition immediately without any preheating (see chapter 2.8.1.1 skip pre heating). A resistor at this pin defines the duration of the pre heating phase. Normally, the pre heating phase is in a range of 0ms up to 2500ms set via a resistor  $R_{RTPH} = 0\Omega$  up to 25k $\Omega$  from the RTPH pin to GND. The pre heating phase is skipped when the RTPH pin is set to GND. If the signal at this pin is  $V_{RTPH} > 5.0\text{ V}$ , the IC remains in the pre heating mode.

#### 2.8.1.1 Skip the Pre Heating Phase – Set RTPH Pin to GND

The Pre Heating phase can be skipped in set the RTPH pin 11 to GND. Figure 28 shows a standard start up with a set pre heating time via resistor at the RTPH pin 11 to GND (e.g. 8.2 k $\Omega$  this is equal to a pre heating phase of app. 820ms). The pre heating phase can be skipped in setting the RTPH pin 11 directly to GND. In that case, the ignition is directly after the soft start phase.

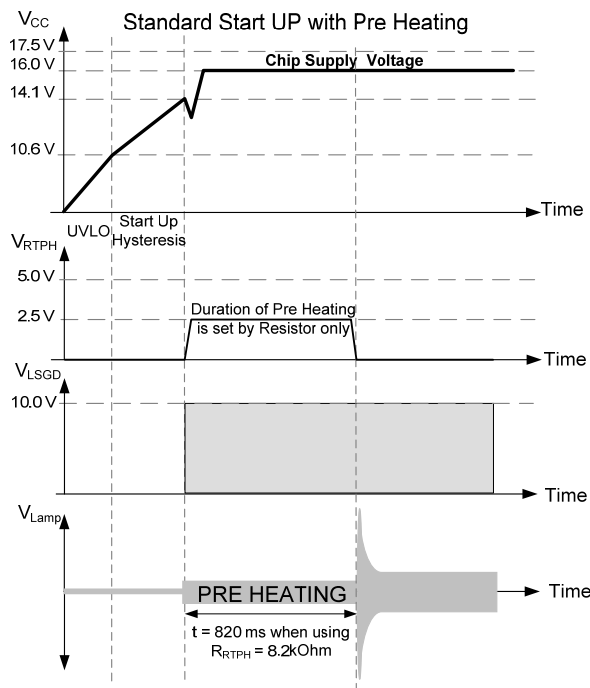

Figure 28 Start UP WITH Pre Heating

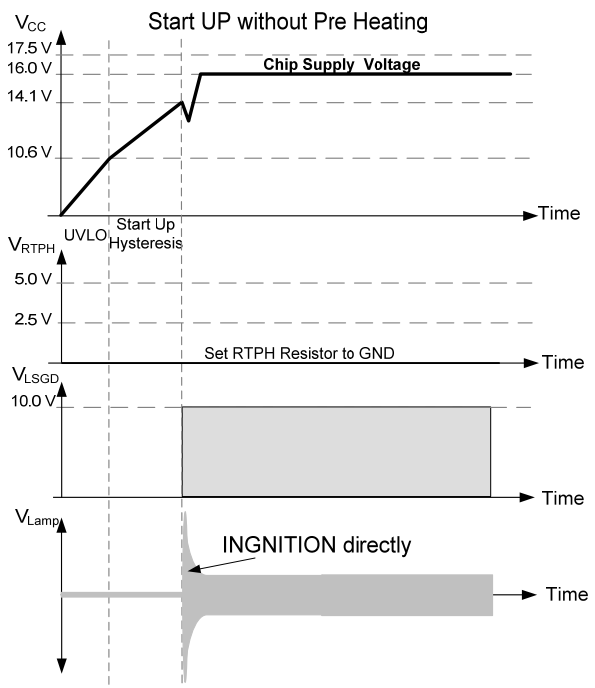

Figure 29 Start UP WITHOUT Pre Heating

2.8.1.2 IC remains in Pre Heating Phase

This feature gives the customer the flexibility to align the pre heating frequency to the filament power in the pre heating phase. Figure 30 shows a standard start up with the set preheating time of e.g. 820ms with an 8.2 kΩ resistor at the RTPH pin 11. To force the IC remains in pre heating, the voltage level at the RTPH pin 11 has to set to 5.0 V. The duration of this 5.0 V signal defines the time of the pre heating see  $I_{PreHeat}$  in figure below.

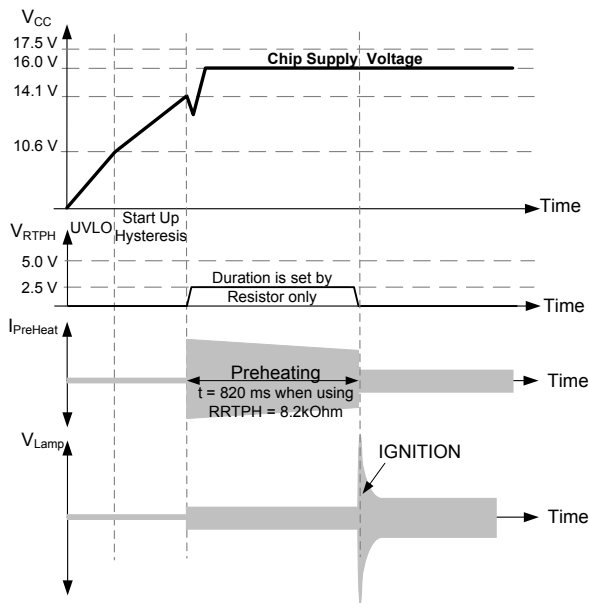

Figure 30 Start UP with Pre Heating

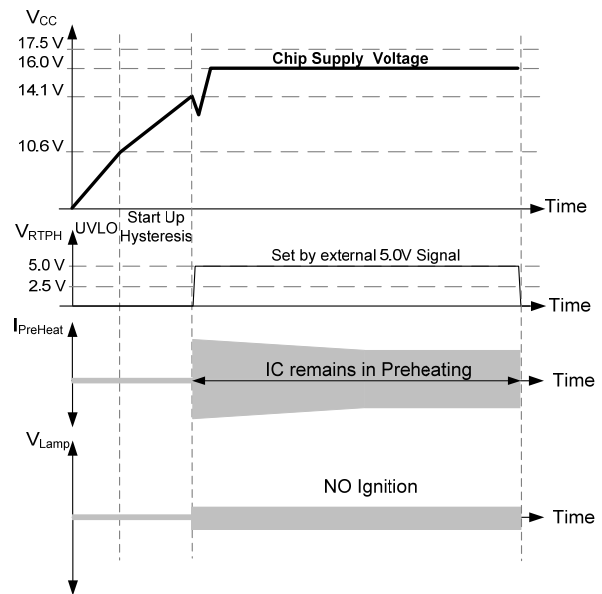

Figure 31 Start UP IC REMAINS in Pre Heating

### 2.8.2 Deactivation of the Filament Detection

In order to deactivate the filament detection of the low or high side filament, set the RES pin 12 or the LVS1 / LVS2 pin 13 / 14 to GND. In that case, the IC starts up into normal operation without checking the filaments e.g. when using an equivalent lamp resistive load instead of a load.

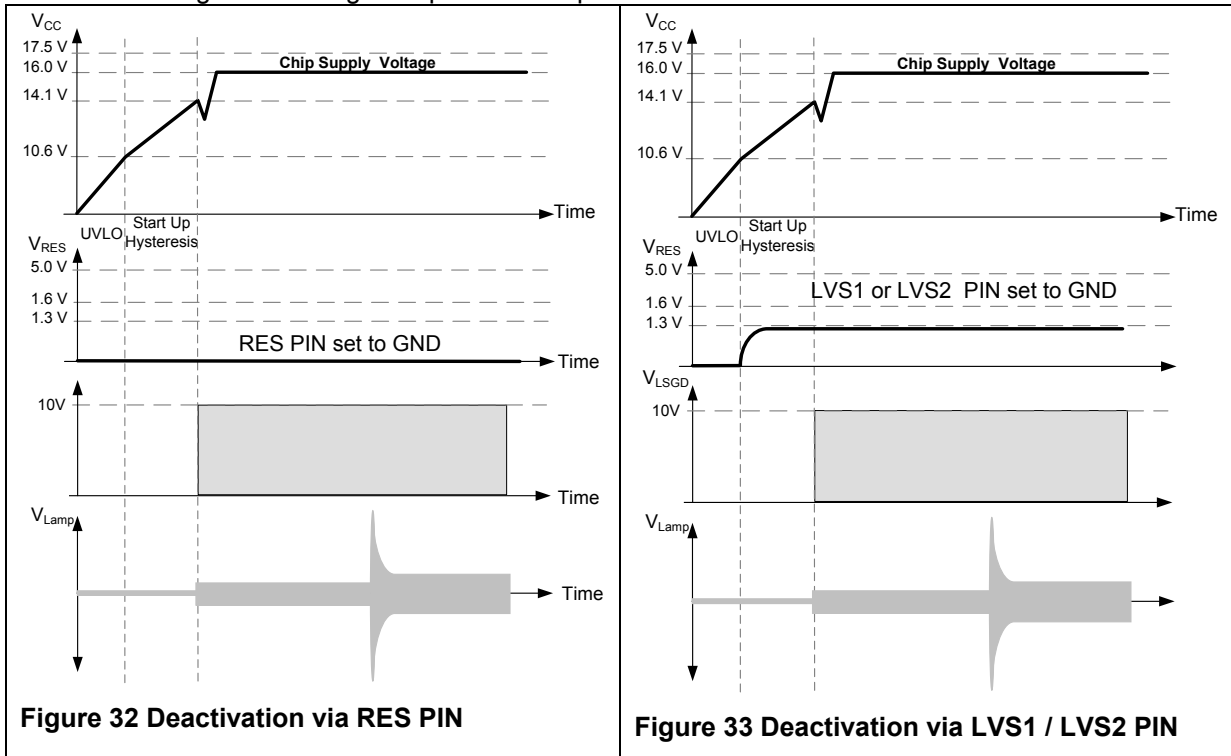

Figure 32 shows the deactivation of the low and high side filament via set the RES pin 12 to GND. Figure 33 shows the deactivation of the high side filament detection via set the LVS1 or LVS2 pin to GND.

**Note**

In case using just one path of a ballast design (single or dual lamp in series) one of the not used LVS pins has to be set to GND.

### 2.8.3 Built in Customer Test Mode (Clock Acceleration)

The built in customer test mode, supported by this IC, saves testing time for customers in terms of ballast end test. In that mode, the IC accelerates the internal clock in order to reduce the time of the 4 different procedures by the following factors (see Table 1).

Phase	Duration for Test [ms]	Acceleration Factor	Nominal Duration [ms]
Preheating	625	4	2500 (max)
Time Out Ignition	118.5	2	237
Pre Run Mode	41.7	15	625
EOL2	41,7	60	2500

Table 1 Specified Acceleration Factors

#### 2.8.3.1 Enabling of the Clock Acceleration

The clock acceleration (Built in Customer Test Mode) is activated when the chip supply voltage exceeds  $V_{CC} > 14.1V$  and the voltages at the Run Frequency and Preheating Frequency pin are set to  $V_{RFRUN} = V_{RFPH} = 5.0V (\pm 5\%)$  see Figure 34 Clock Acceleration (Built in Customer Test Mode). A RES pin voltage of  $V_{RES} > 3.5V$  up to  $5.0V (\pm 5\%)$  prevents a power up of the IC, the IC remains in a mode before powering up. This status is hold as long as the voltage at the RES pin is at  $V_{RES} > 3.5V$  up to  $5.0V (\pm 5\%)$  – no power up. Note: after the activation of the clock acceleration mode, the voltage level of  $5.0V$  at the Run Frequency and Preheating Frequency pin ( $V_{RFRUN} = V_{RFPH}$ ) can be released.

#### 2.8.3.2 Starting the Chip with accelerated Clock

In order to start the IC with an accelerated clock, set the voltage at the RES pin to GND ( $V_{RES} = 0V$ ). Figure 34 Clock Acceleration (Built in Customer Test Mode). The IC powers up the system and starts working with an accelerated clock. Now the duration of the different modes are accelerated by Factors shown in Table 1.

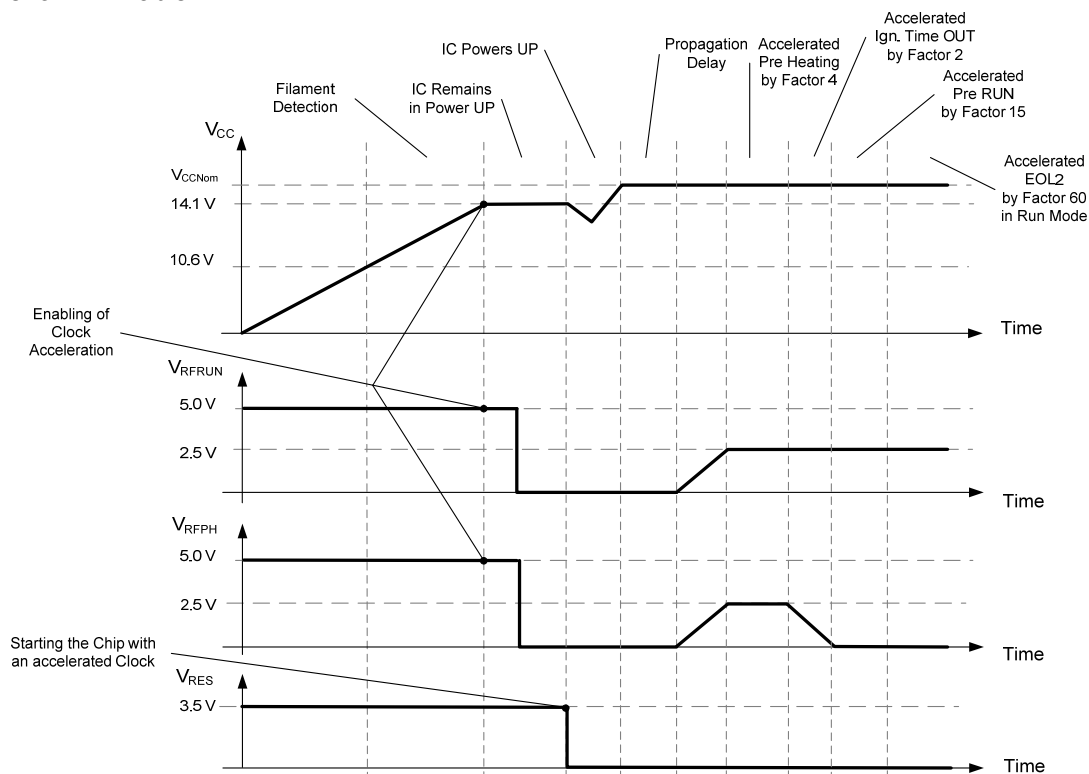

Figure 34 Clock Acceleration (Built in Customer Test Mode)

### 3 State Diagram

#### 3.1 Features during different operating modes

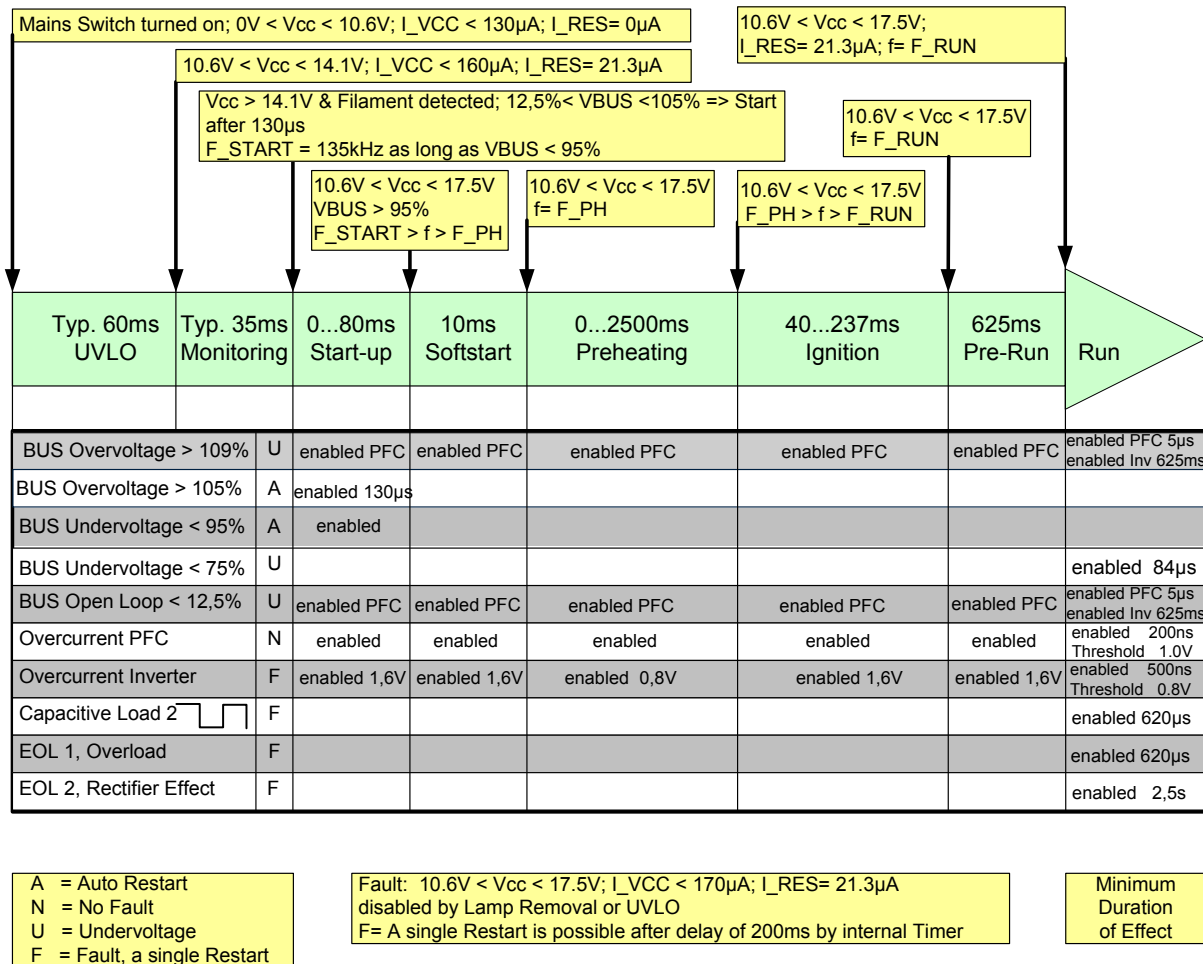

Figure 35 Monitoring Features during different operating Modes

3.2 Operating Flow of the Start UP Procedure into the Run Mode

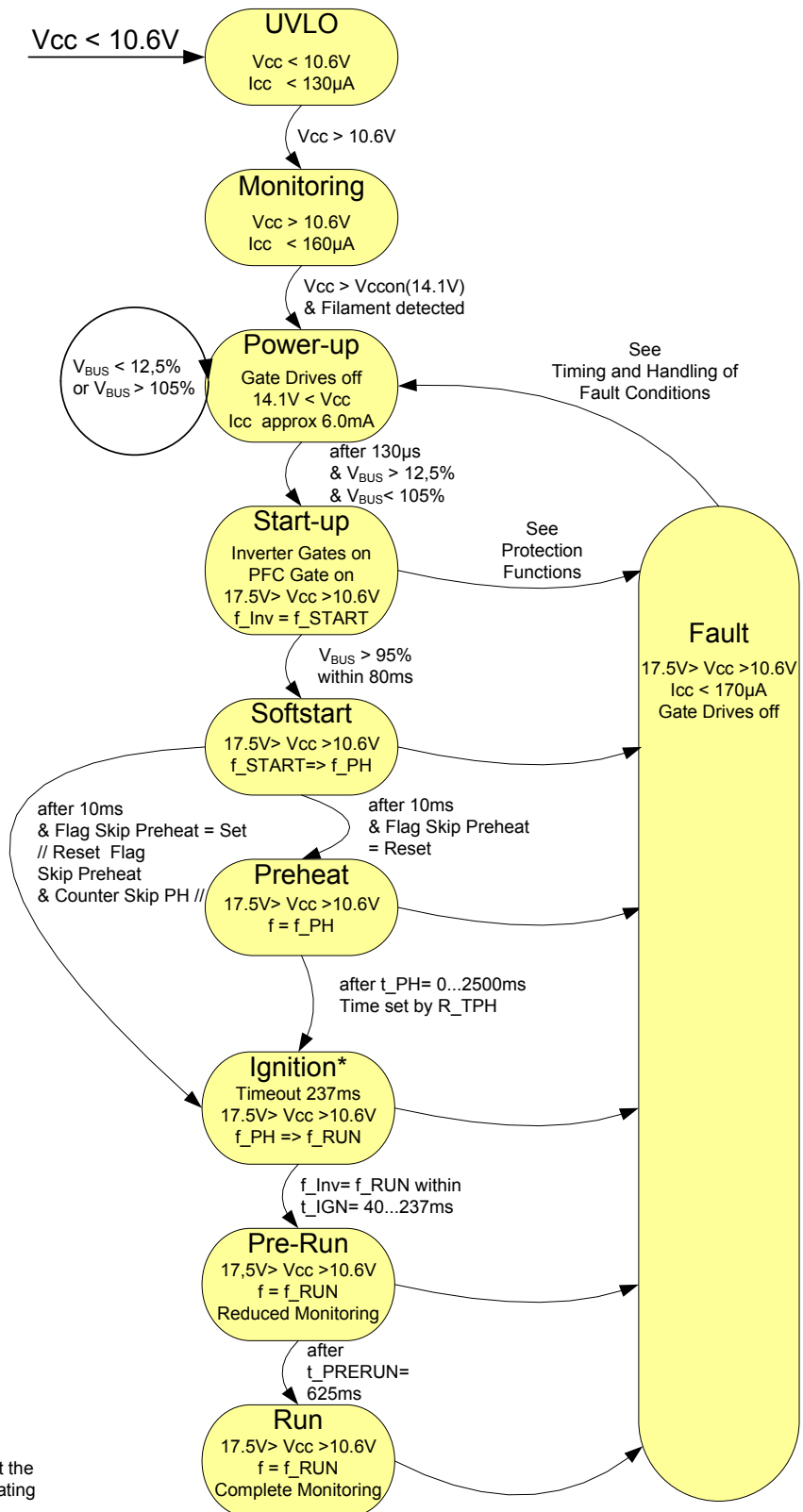

Figure 36 Operating Flow during Start-up Procedure

3.3 Auto Restart and Latched Fault Condition Mode

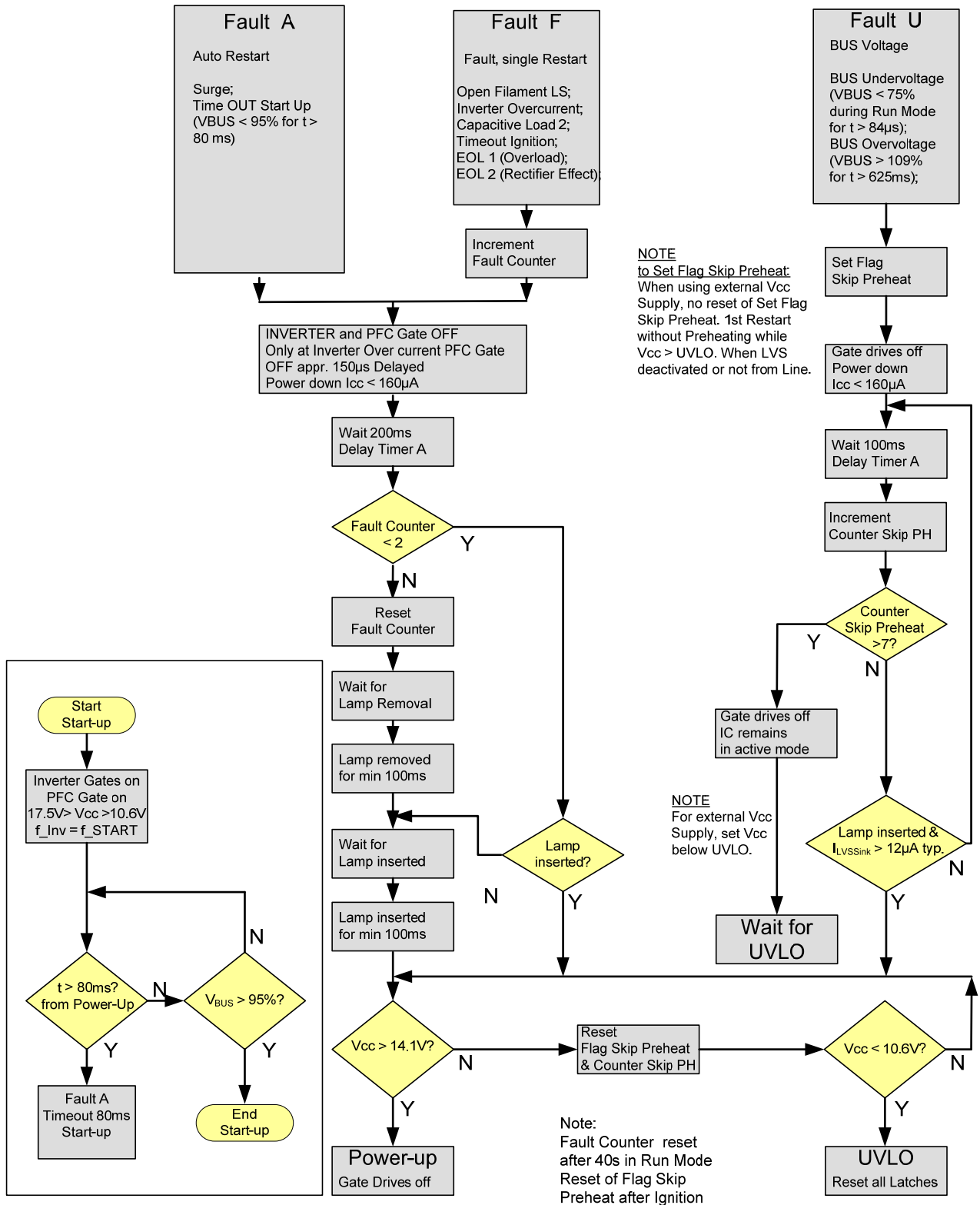

Figure 37 Operating Process during Start-up Mode and Handling of Fault Conditions

## 4 Protection Functions Matrix

Description of Fault	Characteristics of fault			Operating Mode Detection is active								Consequence
	Name of Fault	Type of fault	Minimum Duration of effect	Monitoring	Power-up 130µs	Start-up until VBUS > 95%	Softstart 10ms	Preheat Mode 0 – 2500ms	Ignition Mode 40 – 237ms	Pre-Run Mode 625ms	Run Mode	
Supply voltage Vcc < 14.1V before power up	Below start-up threshold	S	1µs	X								Prevents power up
Supply voltage Vcc < 10.6V after power up	Below UVLO threshold	S	5µs	X	X	X	X	X	X	X	X	Power down, Reset failure latch
Current into LVS1 pin <18µA before power up	open filament HS	S	100µs	X								Prevents power up
Current into LVS2 pin <18µA before power up	open filament HS	S	100µs	X								Prevents power up
Voltage at RES pin > 1.6V before power up	open filament LS	S	100µs	X								Prevents power up
Voltage at RES pin > 3.2V	open filament LS	F	620µs								X	Power down,latched Fault Mode, 1 Restart
Bus voltage < 12.5% of rated level 10µs after power up	Open Loop detection	S	1µs		X							Keep Gate drives off, re-start after Vcc hysteresis
Bus voltage < 12.5% of rated level	Open Loop detection	N	1µs			X	X	X	X	X	X	Stops PFC FET until VBUS > 12.5%
Bus voltage < 12.5% of rated level	Shut down option	U	625ms								X	Power down, restart when VBUS> 12.5%
Bus voltage < 75% of rated level add. shut down delay 120µs	Under-voltage	U	84µs								X	Power down, 100ms delay, restart, skip pre-heating max 7 times
Bus voltage < 95% of rated level during start-up	Timeout max start-up time	A	80ms			X						Power down, 200ms delay, restart
Bus voltage > 105% of rated level 10µs after power up	Over-voltage	S	5µs		X							Keep Gate drives off, re-start after Vcc hysteresis
Bus voltage > 109% of rated level in active operation	PFC Overvoltage	N	5µs			X	X	X	X	X	X	Stops PFC FET until VBUS< 105%
Bus voltage > 109% of rated level in active operation	Inverter Overvoltage	U	625ms								X	Power down, restart when VBUS<105%
+/- peak level of lamp voltage at Pin LVS above threshold	EOL 1 Overvoltage	F	620µs								X	Power down,latched Fault Mode, 1 Restart
DC level of lamp voltage above +/- threshold	EOL 2 Rect. Effect	F	2500ms								X	Power down,latched Fault Mode, 1 Restart
Capacitive Load 2, operation below resonance	Cap.Load 2 Overload	F	620µs								X	Power down,latched Fault Mode, 1 Restart
Run frequency cannot be achieved	Timeout Ignition	F	237ms						X			Power down,latched Fault Mode, 1 Restart
Voltage at PFCCS pin > 1.0V	PFC Overcurrent	N	200ns			X	X	X	X	X	X	Stops on-time of PFC FET immediately
Voltage at LSCS pin > 0.8V	Inverter current lim	N	200ns						X			Activates Ignition control
Voltage at LSCS pin > 0.8V	Inverter overcurrent	F	500ns					X			X	Power down,latched Fault Mode, 1 Restart
Voltage at LSCS pin > 1.6V	Inverter overcurrent	F	500ns			X	X		X	X		Power down,latched Fault Mode, 1 Restart
Voltage at LSCS pin > 0.8V & VBUS > 109% (Surge)	Inverter overcurrent	A	500ns							X	X	Power down, restart when VBUS<109%
After jump into latched fault mode F wait			200ms	A single restart attempt after delay of internal timer								
Reset of failure latch in run mode after			40s	Reset of failure latch by UVLO or 40s in run mode								
S = Start-up condition, N = No Fault, A = Auto-Restart, U = Undervoltage												
F = Fault with a single Restart, a second F leads to a latched fault / <b>Note: all values @ typical 50 Hz mains frequency</b>												



## 5 Electrical Characteristics

Note: All voltages without the high side signals are measured with respect to ground (pin 4). The high side voltages are measured with respect to pin17. The voltage levels are valid if other ratings are not violated.

### Absolute Maximum Ratings

#### 5.1 Absolute Maximum Ratings

Note: Absolute maximum ratings are defined as ratings, which when being exceeded may lead to destruction of the integrated circuit. For the same reason make sure, that any capacitor that will be connected to pin 3 (VCC) and pin 18 (HSVCC) is discharged before assembling the application circuit.

Parameter	Symbol	Limit Values		Unit	Remarks
		min.	max.		
LSCS Voltage	$V_{LSCS}$	- 5	6	V	
LSCS Current	$I_{LSCS}$	- 3	3	mA	
LSGD Voltage	$V_{LSGD}$	- 0.3	$V_{cc}+0.3$	V	Internally clamped to 11V
LSGD Peak Source Current	$I_{LSGDs_{omax}}$	- 75	5	mA	< 500ns
LSGD Peak Sink Current	$I_{LSGDs_{imax}}$	- 50	400	mA	< 100ns
VCC Voltage	$V_{VCC}$	- 0.3	18	V	
VCC Zener Clamp Current	$I_{VCCzener}$	- 5	5	mA	IC in Power Down Mode
PFCGD Voltage	$V_{PFCGD}$	- 0.3	$V_{cc}+0.3$	V	
PFCGD Peak Source Current	$I_{PFCGDs_{omax}}$	- 150	5	mA	< 500ns
PFCGD Peak Sink Current	$I_{PFCGDs_{imax}}$	- 100	700	mA	< 100ns
PFCCS Voltage	$V_{PFCCS}$	- 5	6	V	
PFCCS Current	$I_{PFCCS}$	- 3	3	mA	
PFCZCD Voltage	$V_{PFCZCD}$	- 3	6	V	
PFCZCD Current	$I_{PFCZCD}$	- 5	5	mA	
PFCVS Voltage	$V_{PFCVS}$	- 0.3	5.3	V	
RFRUN Voltage	$V_{RFRUN}$	- 0.3	5.3	V	
RFPH Voltage	$V_{RFPH}$	- 0.3	5.3	V	
RTPH Voltage	$V_{RTPH}$	- 0.3	5.3	V	
RES Voltage	$V_{RES}$	- 0.3	5.3	V	
LVS1 Voltage	$V_{LVS1}$	- 6	7	V	
LVS1 Current1	$I_{LVS1\_1}$	- 1	1	mA	IC in Power Down Mode
LVS1 Current2	$I_{LVS1\_2}$	- 3	3	mA	IC in active Mode
LVS2 Voltage	$V_{LVS2}$	- 6	7	V	
LVS2 Current1	$I_{LVS2\_1}$	- 1	1	mA	IC in Power Down Mode
LVS2 Current2	$I_{LVS2\_2}$	- 3	3	mA	IC in active Mode

### Absolute Maximum Ratings

Parameter	Symbol	Limit Values		Unit	Remarks
		min.	max.		
AUX Voltage	$V_{AUX}$	- 0.3	5.3	V	
HSGND Voltage	$V_{HSGND}$	- 900	900	V	Referring to GND
HSGND Voltage Transient	$dV_{HSGND}/dt$	- 40	40	V/ns	
HSVCC Voltage	$V_{HSVCC}$	- 0.3	18	V	Referring to HSGND
HSGD Voltage	$V_{HSGD}$	- 0.3	$V_{HSVCC}+0.3$	V	Internally clamped to 11V
HSGD Peak Source Current	$I_{HSGD_{smax}}$	- 75	0	mA	< 500ns
HSGD Peak Sink Current	$I_{HSGD_{smax}}$	0	400	mA	< 100ns
Junction Temperature	$T_J$	- 25	150	°C	
Storage Temperature	$T_S$	- 55	150	°C	
Maximum Power Dissipation	$P_{TOT}$	—	2	W	PG_DSO-19-1 $T_{amb}=25^{\circ}C$
Thermal Resistance (2 Chips)	$R_{thJA}$	—	60	K/W	PG_DSO-19-1
Thermal Resistance (HS Chip)	$R_{thJAHS}$	—	120	K/W	PG_DSO-19-1
Thermal Resistance (LS Chip)	$R_{thJALS}$	—	120	K/W	PG_DSO-19-1
Soldering Temperature		—	260	°C	Wave Soldering <sup>1)</sup>
ESD Capability	$V_{ESD}$	—	2	kV	Human Body Model <sup>2)</sup>
Creepage Distance HS vs. LS		1.9	2.0	mm	
Rated Bus Voltage (95%)	$V_{PFCV95}$	2.33	2.43	V	

<sup>1)</sup> According to JESD22A111

<sup>2)</sup> According to EIA/JESD22-A114-B (discharging an 100 pF Capacitor through an 1.5kΩ series Resistor)

## Operating Range

## 5.2 Operating Range

Parameter	Symbol	Limit Values		Unit	Remarks
		min.	Max.		
HSVCC Supply Voltage	$V_{HSVCC}$	$V_{HSVCCoff}$	17.5	V	Referring to HSGND
HSGND Voltage	$V_{HSGND}$	- 900	900	V	Referring to GND
VCC Voltage @ 25°C	$V_{VCC}$	$V_{VCCoff}$	17.5	V	$T_J = 25^\circ\text{C}$
VCC Voltage @ 125°C	$V_{VCC}$	$V_{VCCoff}$	18.0	V	$T_J = 125^\circ\text{C}$
LSCS Voltage Range	$V_{LSCS}$	- 4	5	V	In active Mode
PFCVS Voltage Range	$V_{PFCVS}$	0	4	V	
PFCCS Voltage Range	$V_{PFCCS}$	- 4	5	V	In active Mode
PFZCD Current Range	$I_{PFZCD}$	- 3	3	mA	In active Mode
LVS1, LVS2 Voltage Range	$V_{LVS1,LVS2}$	- 6	6 <sup>1)</sup>	V	
LVS1, LVS2 Current Range	$I_{LVS1,LVS2}$	<sup>2)</sup>	210	μA	IC Power Down Mode
LVS1, LVS2 Current Range	$I_{LVS1,LVS2}$	- 2.5	2.5	mA	IC active Mode
RFPH Frequency	$F_{RFPHrange}$	$F_{RUN}$	150	kHz	
RFPH Source Current Range	$I_{RFPH}$	- 500	0	μA	@ $V_{RFPH} = 2.5\text{V}$
RTPH Voltage Range	$V_{RTPH}$	0	2.5	V	
Junction Temperature	$T_J$	- 25	125	°C	
Adjustable Preheating Freq.	$F_{RFPH}$	$F_{RFRUN}$	150	kHz	Range set by RFPH
Adjustable Run Frequency	$F_{RFRUN}$	20	120 <sup>3)</sup>	kHz	Range set by RFRUN
Adjustable Preheating Time	$t_{RTPH}$	0	2500	ms	Range set by RTPH
Set Resistor for Run Feq.	$R_{RFRUN}$	4	25	kΩ	
Set Resistor for Preheat Feq.	$R_{RFPH}$	4	—	kΩ	$R_{RFRUN}$ parallel to $R_{RFPH}$
Set Resistor for Preheat Time	$R_{RTPH}$	0	25	kΩ	
Mains Frequency	$f_{Mains}$	45	65	Hz	NOTCH Filter Operation

<sup>1)</sup> Limited by Maximum of Current Range at LVS1, LVS2

<sup>2)</sup> Limited by Minimum of Voltage Range at LVS1, LVS2

<sup>3)</sup> For higher Run-frequencies the maximum Load to the Gate-Drives must be smaller

## 5.3 Characteristics

## 5.3.1 Power Supply Section

Note: The electrical Characteristics involve the spread of values given within the specified supply voltage and junction temperature range  $T_J$  from  $-25\text{ }^\circ\text{C}$  to  $125\text{ }^\circ\text{C}$ . Typical values represent the median values, which are related to  $25\text{ }^\circ\text{C}$ . If not otherwise stated, a supply voltage of  $15\text{V}$  and  $V_{HSVCC} = 15\text{V}$  is assumed and the IC operates in active mode. Furthermore, all voltages are referring to GND if not otherwise mentioned.

Parameter	Symbol	Limit Values			Unit	Test Condition
		min.	typ.	max.		
VCC Quiescent Current1	$I_{VCCqu1}$	—	90	130	$\mu\text{A}$	$V_{VCC} = V_{VCCoff} - 0.5\text{V}$
VCC Quiescent Current2	$I_{VCCqu2}$	—	120	160	$\mu\text{A}$	$V_{VCC} = V_{VCCOn} - 0.5\text{V}$
VCC Supply Current <sup>2)</sup>	$I_{VCCSupply}$	—	4.2	6.0	$\text{mA}$	$V_{PFCVS} > 2.725\text{V}$
VCC Supply Current in Latched Fault Mode	$I_{VCCLatch}$	—	110	170	$\mu\text{A}$	$V_{RES} = 5\text{V}$
LSVCC Turn-On Threshold	$V_{VCCOn}$	13.6	14.1	14.6	$\text{V}$	Hysteresis
LSVCC Turn-Off Threshold	$V_{VCCOff}$	10.0	10.6	11.0	$\text{V}$	
LSVCC Turn-On/Off Hyst.	$V_{VCCHys}$	3.2	3.6	4.0	$\text{V}$	
VCC Zener Clamp Voltage	$V_{VCCClamp}$	15.5	16.3	16.9	$\text{V}$	$I_{VCC} = 2\text{mA}/V_{RES} = 5\text{V}$
VCC Zener Clamp Current	$I_{VCCZener}$	2.5	—	5	$\text{mA}$	$V_{VCC} = 17.5\text{V}/V_{RES} = 5\text{V}$
High Side Leakage Current	$I_{HSGNDleak}$	—	0.01	2	$\mu\text{A}$	$V_{HSGND} = 800\text{V}, V_{GND} = 0\text{V}$
HSVCC Quiescent Current	$I_{HSVCCqu1}$ <sup>1)</sup>	—	170	250	$\mu\text{A}$	$V_{HSVCC} = V_{HSVCCOn} - 0.5\text{V}$
HSVCC Quiescent Current <sup>2)</sup>	$I_{HSVCCqu2}$ <sup>1)</sup>	0.3	0.65	1.2	$\text{mA}$	$V_{HSVCC} > V_{HSVCCOn}$
HSVCC Turn-On Threshold	$V_{HSVCCOn}$ <sup>1)</sup>	9.6	10.1	10.7	$\text{V}$	Hysteresis
HSVCC Turn-Off Threshold	$V_{HSVCCOff}$ <sup>1)</sup>	7.9	8.4	9.1	$\text{V}$	
HSVCC Turn-On/Off Hyst.	$V_{HSVCCHy}$ <sup>1)</sup>	1.4	1.7	2.0	$\text{V}$	
Low Side Ground	GND					

<sup>1)</sup> Referring to High Side Ground (HSGND)

<sup>2)</sup> With inactive Gate

**Electrical Characteristics**

## 5.3.2 PFC Section

**5.3.2.1 PFC Current Sense (PFCCS)**

Parameter	Symbol	Limit Values			Unit	Test Condition
		min.	typ.	max.		
Turn – Off Threshold	$V_{PFCCSOff}$	0.95	1.0	1.05	V	
Over Current Blanking + Propagation Delay <sup>1)</sup>	$t_{PFCCSOff}$	140	200	260	ns	
Leading Edge Blanking	$t_{Blanking}$	180	250	310	ns	Pulse Width when $V_{PFCCS} > 1.0V$
PFCCS Bias Current	$I_{PFCCSBias}$	- 0.5	—	0.5	$\mu A$	$V_{PFCCS} = 1.5V$

<sup>1)</sup> Propagation Delay = 50ns

**5.3.2.2 PFC Zero Current Detection (PFCZCD)**

Parameter	Symbol	Limit Values			Unit	Test Condition
		min.	typ.	max.		
Zero Crossing upper Thr. <sup>1)</sup>	$V_{PFCZCDUp}$	1.4	1.5	1.6	V	
Zero Crossing lower Thr. <sup>2)</sup>	$V_{PFCZCDLow}$	0.4	0.5	0.6	V	
Zero Crossing Hysteresis	$V_{PFCZCDHys}$	—	1.0	—	V	
Clamping of pos. Voltages	$V_{PFCZCDpclip}$	4.1	4.6	5.1	V	$I_{PFCZCDSink} = 2mA$
Clamping of neg. Voltages	$V_{PFCZCDnclip}$	- 1.7	- 1.4	- 1.0	V	$I_{PFCZCDSource} = - 2mA$
PFCZCD Bias Current	$I_{PFCZCDBias}$	- 0.5	—	5.0	$\mu A$	$V_{PFCZCD} = 1.5V$
PFCZCD Bias Current	$I_{PFCZCDBias}$	- 0.5	—	0.5	$\mu A$	$V_{PFCZCD} = 0.5V$
PFCZCD Ringing Su. <sup>3)</sup> Time	$t_{Ringsup}$	350	500	650	ns	
Limit Value for ON Time Extension	$\Delta t \times I_{ZCD}$	500	700	900	pAxs	

<sup>1)</sup> Turn OFF Threshold

<sup>2)</sup> Turn ON Threshold

<sup>3)</sup> Ringing Suppression Time

**5.3.2.3 PFC Bus Voltage Sense (PFCVS)**

Parameter	Symbol	Limit Values			Unit	Test Condition
		min.	Typ.	max.		
Trimmed Reference Voltage	$V_{PFCVSRef}$	2.47	2.50	2.53	V	$\pm 1.2 \%$
Overvoltage turn Off (109%)	$V_{PFCVSRUp}$	2.68	2.73	2.78	V	
Overvoltage turn On (105%)	$V_{PFCVSLow}$	2.57	2.63	2.68	V	
Overvoltage Hysteresis	$V_{PFCVSHys}$	70	100	130	mV	4 % rated Bus Voltage
Under voltage (75%)	$V_{PFCVSUV}$	1.835	1.88	1.915	V	
Under voltage (12.5%)	$V_{PFCVSUV}$	0.237	0.31	0.387	V	
Rated Bus Voltage (95%)	$V_{PFCVS95}$	2.325	2.38	2.425	V	
PFCVS Bias Current	$I_{PFCVSBias}$	- 1.0	—	1.0	$\mu A$	$V_{PFCVS} = 2.5V$

**Electrical Characteristics**
**5.3.2.4 PFC PWM Generation**

Parameter	Symbol	Limit Values			Unit	Test Condition
		min.	Typ.	max.		
Initial ON – Time <sup>1)</sup>	$t_{PFCON\_initial}$	—	4.0	—	$\mu s$	$V_{PFCZCD} = 0V$
Max. ON – Time <sup>2)</sup>	$t_{PFCON\_max}$	18	22.7	26	$\mu s$	$0.45V < V_{PFCVS} < 2.45V$
Switch Threshold from CritCM into DCM	$t_{PFCON\_min}$	160	270	370	ns	
Repetition Time <sup>1)</sup>	$t_{PFCRep}$	47	52	57	$\mu s$	$V_{PFCZCD} = 0V$
Off Time	$t_{PFCOff}$	42	47	52	$\mu s$	

<sup>1)</sup> When missing Zero Crossing Signal

<sup>2)</sup> At the Maxima of the AC Line Input Voltage

**5.3.2.5 PFC Gate Drive (PFCGD)**

Parameter	Symbol	Limit Values			Unit	Test Condition
		min.	Typ.	max.		
PFCGD Low Voltage	$V_{PFCGDLow}$	0.4	0.7	0.9	V	$I_{PFCGD} = 5mA$
		0.4	0.75	1.1	V	$I_{PFCGD} = 20mA$
		- 0.2	0.3	0.6	V	$I_{PFCGD} = -20mA$
PFCGD High Voltage	$V_{PFCGDHigh}$	10.0	11.0	11.6	V	$I_{PFCGD} = -20mA$
		9.0	—	—	V	$I_{PFCGD} = -1mA / V_{VCC}^{1)}$
		8.5	—	—	V	$I_{PFCGD} = -5mA / V_{VCC}^{1)}$
PFCGD active Shut Down	$V_{PFCGASD}$	0.4	0.75	1.1	V	$I_{PFCGD} = 20mA V_{VCC}=5V$
PFCGD UVLO Shut Down	$V_{PFCGDuvlo}$	0.3	1.0	1.5	V	$I_{PFCGD} = 5mA V_{VCC}=2V$
PFCGD Peak Source Current	$I_{PFCGDSouce}$	—	- 100	—	mA	<sup>2) + 3)</sup>
PFCGD Peak Sink Current	$I_{PFCGDSink}$	—	500	—	mA	<sup>2) + 3)</sup>
PFCGD Voltage during sink Current	$V_{PFCGDHigh}$	11.0	11.7	12.3	V	$I_{PFCGDSinkH} = 3mA$
PFC Rise Time	$V_{PFCGDRise}$	80	220	380	ns	$2V > V_{LSDG} > 8V^{2)}$
PFC Fall Time	$V_{PFCGDFall}$	20	45	70	ns	$8V > V_{LSDG} > 2V^{2)}$

<sup>1)</sup>  $V_{VCC} = V_{VCCoff} + 0.3V$

<sup>2)</sup>  $R_{Load} = 4\Omega$  and  $C_{Load} = 3.3nF$

<sup>3)</sup> The Parameter is not Subject to Production Test – verified by Design / Characterization

**5.3.2.6 Auxiliary (AUX)**

Parameter	Symbol	Limit Values			Unit	Test Condition
		min.	typ.	max.		
AUX Voltage OFF Level	$V_{AUXOff}$	—	—	0.24	V	$I_{AUX} = 1mA$
AUX Voltage ON Level 1	$V_{AUXOn1}$	1.7	2.6	3.1	V	$I_p = 0A^{1)}$
AUX Voltage ON Level 2	$V_{AUXOn2}$	1.8	2.6	3.1	V	$I_p = 1mA^{1)}$
AUX Current	$I_{AUX}$	- 0.60	-0.45	- 0.3	mA	$V_{AUX} = 1V / I_p = 0A$

<sup>1)</sup>  $I_p$  = the positive Current into PIN ZCD

## 5.3.3 Inverter Section

## 5.3.3.1 Low Side Current Sense (LSCS)

Parameter	Symbol	Limit Values			Unit	Test Condition
		min.	typ.	max.		
Overcurrent Shut Down Volt.	$V_{LSCSOVC1}$	1.5	1.6	1.7	V	<sup>1)</sup>
Overcurrent Shut Down Volt.	$V_{LSCSOVC2}$	0.75	0.8	0.85	V	<sup>2)</sup>
Duration of Overcurrent	$t_{LSCSOVC}$	450	600	700	ns	
Capacitive Mode Det. Level 2	$V_{LSCSCap2}$	1.8	2.0	2.2	V	During Run Mode
Capacitive Mode Duration 2	$t_{LSCSCap2}$	—	50	—	ns	<sup>3)</sup>
Capacitive Mode Det. Level 3	$V_{LSCSCap3}$	-70	-50	-27	mV	
Capacitive Mode Duration 3	$t_{LSCSCap3}$	—	280	—	ns	<sup>4)</sup>
LSCS Bias Current	$I_{LSCSBias}$	-1.0	—	1.0	$\mu$ A	@ $V_{LSCS} = 1.5V$

<sup>1)</sup> Overcurrent Voltage Threshold active during: Start Up, Soft start, Ignition and Pre Run Mode

<sup>2)</sup> Overcurrent Voltage Threshold active during: Preheating and Run Mode

<sup>3)</sup> Active during Turn ON of the HSGD in Run Mode

<sup>4)</sup> Active before Turn ON of the HSGD in Run Mode

## Electrical Characteristics

## 5.3.3.2 Low Side Gate Drive (LSGD)

Parameter	Symbol	Limit Values			Unit	Test Condition
		min.	typ.	max.		
LSGD Low Voltage	$V_{\text{LSGDLow}}$	0.4	0.7	1.0	V	$I_{\text{LSGD}} = 5\text{mA}^{5)}$
		0.4	0.8	1.2	V	$I_{\text{LSGD}} = 20\text{mA}^{5)}$
		- 0.3	0.2	0.5	V	$I_{\text{LSGD}} = - 20\text{mA}$ (Source)
LSGD High Voltage	$V_{\text{LSGDHigh}}$	10.0	10.8	11.6	V	<sup>1)</sup>
		9.0	—	—	V	<sup>2)</sup>
		8.5	—	—	V	<sup>3)</sup>
LSGD active Shut Down	$V_{\text{LSGDASD}}$	0.4	0.75	1.1	V	$V_{\text{CC}}=5\text{V} / I_{\text{LSGD}} = 20\text{mA}^{5)}$
LSGD UVLO Shut Down	$V_{\text{LSGDUVLO}}$	0.3	1.0	1.5	V	$V_{\text{CC}}=2\text{V} / I_{\text{LSGD}} = 5\text{mA}^{5)}$
LSGD Peak Source Current	$I_{\text{LSGDSource}}$	—	- 50	—	mA	<sup>4) + 6)</sup>
LSGD Peak Sink Current	$I_{\text{LSGDSink}}$	—	300	—	mA	<sup>4) + 6)</sup>
LSGD Voltage during <sup>5)</sup>	$V_{\text{LSGDHigh}}$	—	11.7	—	V	$I_{\text{LSGDsinkH}} = 3\text{mA}$
LSGD Rise Time	$t_{\text{LSGDRise}}$	80	220	380	ns	$2\text{V} < V_{\text{LSGD}} < 8\text{V}^{4)}$
LSGD Fall Time	$t_{\text{LSGDFall}}$	20	35	60	ns	$8\text{V} > V_{\text{LSGD}} > 2\text{V}^{4)}$

<sup>1)</sup>  $I_{\text{LSGD}} = - 20\text{mA}$  Source Current

<sup>2)</sup>  $V_{\text{CCOFF}} + 0.3\text{V}$  and  $I_{\text{LSGD}} = - 1\text{mA}$  Source Current

<sup>3)</sup>  $V_{\text{CCOFF}} + 0.3\text{V}$  and  $I_{\text{LSGD}} = - 5\text{mA}$  Source Current

<sup>4)</sup> Load:  $R_{\text{Load}} = 10\Omega$  and  $C_{\text{Load}} = 1\text{nF}$

<sup>5)</sup> Sink Current

<sup>6)</sup> The Parameter is not Subject to Production Test – verified by Design / Characterization



**Electrical Characteristics**
**5.3.3.3 Inverter Control Run (RFRUN)**

Parameter	Symbol	Limit Values			Unit	Test Condition
		min.	typ.	max.		
Fixed Start – Up Frequency	$F_{StartUp}$	121.5	135	148.5	kHz	
Duration of Soft Start	$t_{SoftStart}$	9	11	13.5	ms	<sup>1)</sup>
RFRUN Voltage in Run Mode	$V_{RFRUN}$	—	2.5	—	V	@ $100\mu A < I_{RFRUN} < 600\mu A$
Run Frequency	$F_{RFRUN}$	49	50	51	kHz	$R_{RFRUN} = 10k\Omega$
Adjustable Run Frequency	$F_{RFRUN1}$	—	20	—	kHz	$I_{RFRUN} = -100\mu A$
	$F_{RFRUN2}$	—	40	—	kHz	$I_{RFRUN} = -200\mu A$
	$F_{RFRUN3}$	—	100	—	kHz	$I_{RFRUN} = -500\mu A$
RFRUN max. Current Range	$I_{RFRUNmax}$	—	-1000	-650	$\mu A$	@ $V_{RFRUN} = 0V$

<sup>1)</sup> Shift Start Up Frequency to Preheating Frequency

**5.3.3.4 Inverter Control Preheating (RFPH, RTPH)**

Parameter	Symbol	Limit Values			Unit	Test Condition
		min.	typ.	max.		
RFPH Voltage Preheating	$V_{RFPH}$	—	2.5	—	V	$V_{RFPH} = 0V$ in Run Mode
Preheating Frequency	$F_{RFPH1}$	97	100	103	kHz	$R_{RFPH} = R_{RFRUN} = 10k\Omega$
RFPH max. Current Range	$I_{RFPHmax}$	—	-1000	-550	$\mu A$	@ $V_{RFPH} = 0V$
Current for set Preh. Time	$I_{RTPH}$	—	-100	—	$\mu A$	
Preheating Time	$t_{RTPH1}$	950	1000	1050	ms	$R_{RTPH1} = 10k\Omega$
	$t_{RTPH2}$	50	100	150	ms	$R_{RTPH2} = 1k\Omega$
	$t_{RTPH3}$	—	500	—	ms	$R_{RTPH3} = 5k\Omega$
	$t_{RTPH4}$	—	2000	—	ms	$R_{RTPH4} = 20k\Omega$
	$t_{RTPH5}$	—	2500	—	ms	$R_{RTPH5} = 25k\Omega$

**Electrical Characteristics**
**5.3.3.5 Restart after Lamp Removal (RES)**

Parameter	Symbol	Limit Values			Unit	Test Condition
		min.	typ.	max.		
High Side Filament In Det.	$V_{RES1}$	1.55	1.60	1.65	V	UVLO, $V_{CC} < V_{CCON}$
	$V_{RES2}$	1.25	1.30	1.35	V	
	$V_{RES3}$	—	3.2	—	V	Run Mode
RES Current Source	$I_{RES1}$	- 53.2	-42.6	-32.0	$\mu$ A	$V_{RES} = 1V$ ; $LVS1 = 5\mu A$
	$I_{RES2}$	-44.2	-35.4	-26.6	$\mu$ A	$V_{RES} = 2V$ ; $LVS1 = 5\mu A$
	$I_{RES3}$	- 26.6	-21.3	- 16.0	$\mu$ A	$V_{RES} = 1V$ ; $LVS1 = 30\mu A$
	$I_{RES4}$	- 22.1	-17.7	-13.3	$\mu$ A	$V_{RES} = 2V$ ; $LVS1 = 30\mu A$

**5.3.3.6 Lamp Voltage Sense (LVS1, LVS2)**

Parameter	Symbol	Limit Values			Unit	Test Condition
		min.	typ.	max.		
Source Current before Startup	$I_{LVSSource}$	- 5.0	- 3.0	- 2.0	$\mu$ A	$V_{LVS} = 0V$
Enable Lamp Monitoring	$V_{LVSEnable1}$	350	530	750	mV	<sup>1)</sup>
Sink Current for Lamp Det.	$I_{LVSSink}$	8.0	12.0	18.0	$\mu$ A	$V_{LVS} > V_{LVSClamp}$
Positive Clamping Voltage	$V_{LVSClamp}$	—	6.5	—	V	@ $I_{LVS} = 300\mu A$
AC EOLCurrent Threshold	$I_{LVSSourceAC}$	190	210	230	$\mu$ App	$I_{LVS} > I_{LVSEOLpp}$ EOL 1
Positive EOL Current Thr.	$I_{LVSDCPos}$	34	42	50	$\mu$ A	$I_{LVS} > I_{LVSDCPos}$ EOL 2
Negative EOL Current Thr.	$I_{LVSDCNeg}$	- 50	- 42	- 34	$\mu$ A	$I_{LVS} > I_{LVSDCNeg}$ EOL 2

<sup>1)</sup> If  $V_{LVS} < V_{LVSEnable1}$  Monitoring is disabled

### 5.3.3.7 High Side Gate Drive (HSGD)

Parameter	Symbol	Limit Values			Unit	Test Condition
		Min.	typ.	max.		
HSGD Low Voltage	$V_{HSGDLow}$	0.02	0.05	0.1	V	$I_{HSGD} = 5mA$ (sink)
		0.5	1.1	2.5	V	$I_{HSGD} = 100mA$ (sink)
		- 0.4	- 0.2	- 0.05	V	$I_{LSGD} = - 20mA$ (source)
HSGD High Voltage	$V_{HSGDHigh}$	9.7	10.5	11.2	V	$V_{CCHS}=15V$ $I_{HSGD} = - 20mA$ (source)
		7.8	—	—	V	$V_{CCHSOFF} + 0.3V$ $I_{HSGD} = - 1mA$ (source)
HSGD active Shut Down	$V_{HSGDASD}$	0.05	0.22	0.5	V	$V_{CCHS}=5V$ $I_{HSGD} = 20mA$ (sink)
HSGD Peak Source Current	$I_{HSGDSource}$	—	- 50	—	mA	$R_{Load} = 10\Omega + C_{Load} = 1nF$ <sup>1)</sup>
HSGD Peak Sink Current	$I_{HSGDSink}$	—	300	—	mA	$R_{Load} = 10\Omega + C_{Load} = 1nF$ <sup>1)</sup>
HSGD Rise Time	$T_{HSGDRise}$	140	220	300	ns	$2V < V_{LSGD} < 8V$ $R_{Load} = 10\Omega + C_{Load} = 1nF$
HSGD Fall Time	$T_{HSGDFall}$	20	35	70	ns	$8V > V_{LSGD} > 2V$ $R_{Load} = 10\Omega + C_{Load} = 1nF$

<sup>1)</sup> The Parameter is not Subject to Production Test – verified by Design / Characterization

### 5.3.3.8 Timer Section

Delay Timer 1	$t_{TIMER1}$	70	100	160	ms	For Lamp Detection
Delay Timer 2	$t_{TIMER2}$	74	84	94	ms	For $V_{BUS} > 95\%$
Inverter Time	$t_{inv}$	100	130	160	$\mu s$	
Inverter Dead Time Max	$t_{DeadMax}$	1.75	2.0	2.25	$\mu s$	
Inverter Dead Time Min	$t_{DeadMin}$	0.8	1.05	1.3	$\mu s$	
$\Delta$ Inverter Dead Time Max	$t_{DeadMax}$	- 200	—	200	ns	
$\Delta$ Inverter Dead Time Min	$t_{DeadMin}$	- 200	—	200	ns	
Min. Duration of Ignition	$t_{Ignition}$	34	40	48	ms	
Max. Duration of Ignition	$t_{NOIgnition}$	197	—	236	ms	
Duration of Pre – Run	$t_{PRERUN}$	565	625	685	ms	

### 5.3.3.9 Built in Customer Test Mode

Voltage at RTPH Pin	$V_{RTPH}$	0	V	Preheating Time = 0ms (Skipped Preheating)
Voltage at RTPH Pin	$V_{RTPH}$	5.0	V <sup>1)</sup>	IC remains in Preheating
Voltage at LVS1 / LVS2 Pin	$V_{LVS1,2}$	0	V	Disables Lamp Voltage Sense
Voltage at RES Pin	$V_{RES}$	0	V	Disable the Filament Detection
Voltage at RFPH Pin	$V_{RFPH}$	5.0	V <sup>1)</sup>	Built in Customer Test Mode - Clock Acceleration. Decreasing Time for the following Procedures. Preheating by Factor 4 Timeout Ignition by Factor 2 Pre RUN by Factor 15; EOL by 60
Voltage at RFRUN Pin	$V_{RFRUN}$	5.0	V <sup>1)</sup>	
Voltage at $V_{CC}$ Pin	$V_{CC}$	> 14.1	V	
Voltage at RES Pin	$V_{RES}$	0	V	

<sup>1)</sup> Tolerance for this voltage is:  $\pm 5\%$ ; Enlarged tolerance for these voltages is:  $-5\% / +10\%$  for a temperature range between  $-25^\circ C$  and  $40^\circ C$

## 6 Application Example

### 6.1 Schematic Ballast 54W T5 Single Lamp

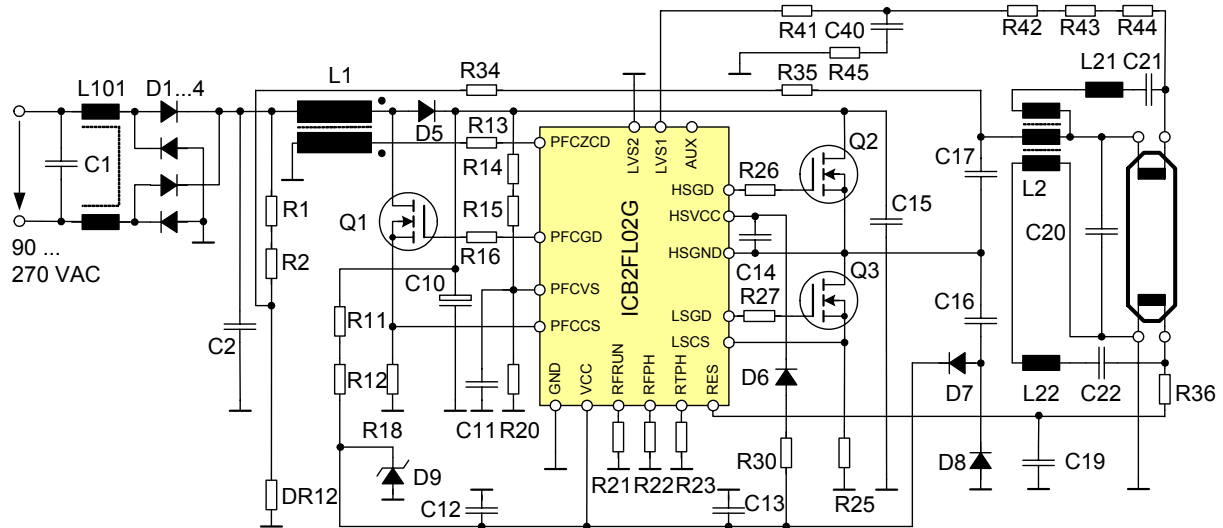

Figure 38: Application Circuit of Ballast for single Fluorescent Lamp Voltage Mode Preheating



### 6.3 Multi Lamp Ballast Topologies

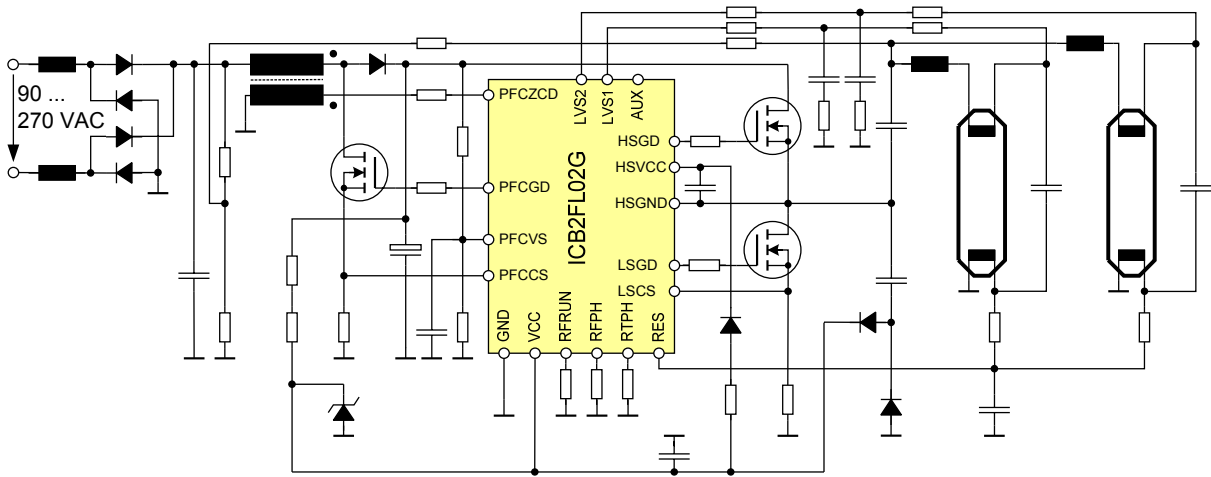

Figure 39: Application Circuit of Ballast for two Fluorescent Lamps Current Mode Preheating

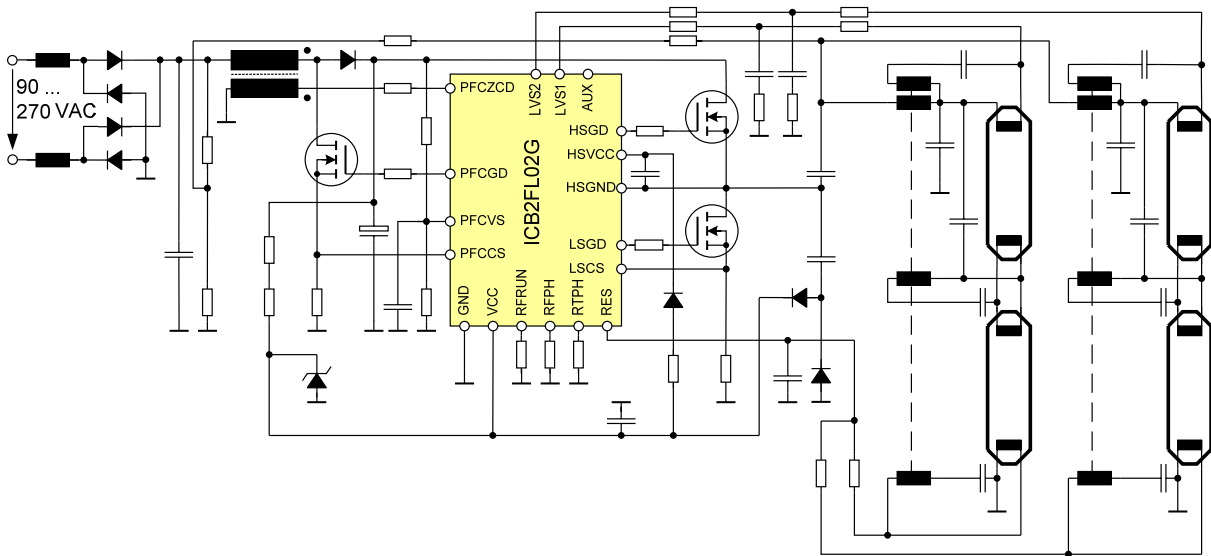

Figure 40: Application Circuit of Ballast for four Fluorescent Lamps Voltage Mode Preheating





Компания «ЭлектроПласт» предлагает заключение долгосрочных отношений при поставках импортных электронных компонентов на взаимовыгодных условиях!

Наши преимущества:

- Оперативные поставки широкого спектра электронных компонентов отечественного и импортного производства напрямую от производителей и с крупнейших мировых складов;
- Поставка более 17-ти миллионов наименований электронных компонентов;
- Поставка сложных, дефицитных, либо снятых с производства позиций;
- Оперативные сроки поставки под заказ (от 5 рабочих дней);
- Экспресс доставка в любую точку России;
- Техническая поддержка проекта, помощь в подборе аналогов, поставка прототипов;
- Система менеджмента качества сертифицирована по Международному стандарту ISO 9001;
- Лицензия ФСБ на осуществление работ с использованием сведений, составляющих государственную тайну;
- Поставка специализированных компонентов (Xilinx, Altera, Analog Devices, Intersil, Interpoint, Microsemi, Aeroflex, Peregrine, Syfer, Eurofarad, Texas Instrument, Miteq, Cobham, E2V, MA-COM, Hittite, Mini-Circuits, General Dynamics и др.);

Помимо этого, одним из направлений компании «ЭлектроПласт» является направление «Источники питания». Мы предлагаем Вам помощь Конструкторского отдела:

- Подбор оптимального решения, техническое обоснование при выборе компонента;
- Подбор аналогов;
- Консультации по применению компонента;
- Поставка образцов и прототипов;
- Техническая поддержка проекта;
- Защита от снятия компонента с производства.



#### Как с нами связаться

**Телефон:** 8 (812) 309 58 32 (многоканальный)

**Факс:** 8 (812) 320-02-42

**Электронная почта:** [org@eplast1.ru](mailto:org@eplast1.ru)

**Адрес:** 198099, г. Санкт-Петербург, ул. Калинина, дом 2, корпус 4, литера А.