

THIS DRAWING IS UNPUBLISHED. RELEASED FOR PUBLICATION
 © COPYRIGHT - By - ALL RIGHTS RESERVED.

LOC		DIST		REVISIONS			
P	LTR	DESCRIPTION	DATE	DWN	APVD		
GP	00						
	U2	REVISED PER ECO-12-011709	26JUN2012	RW	SY		

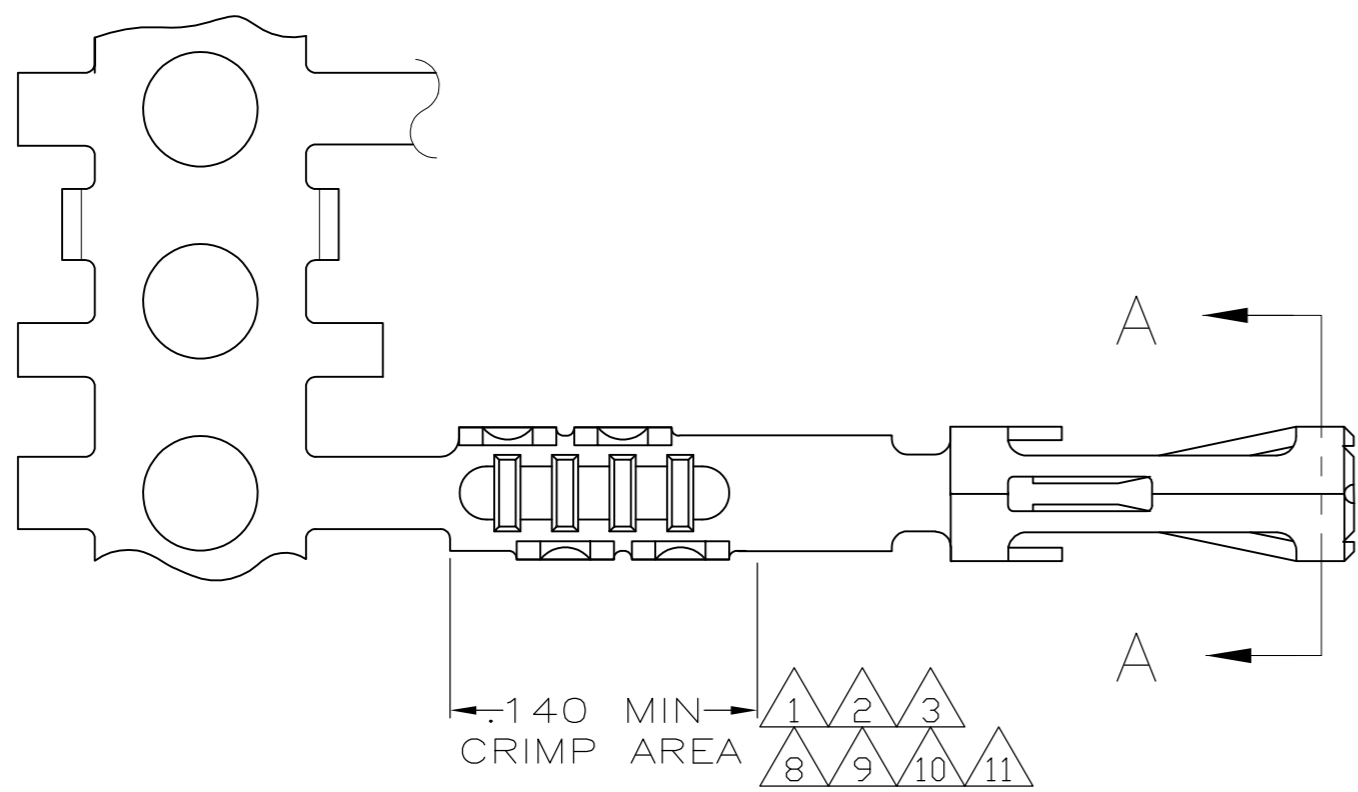

←.140 MIN
CRIMP AREA

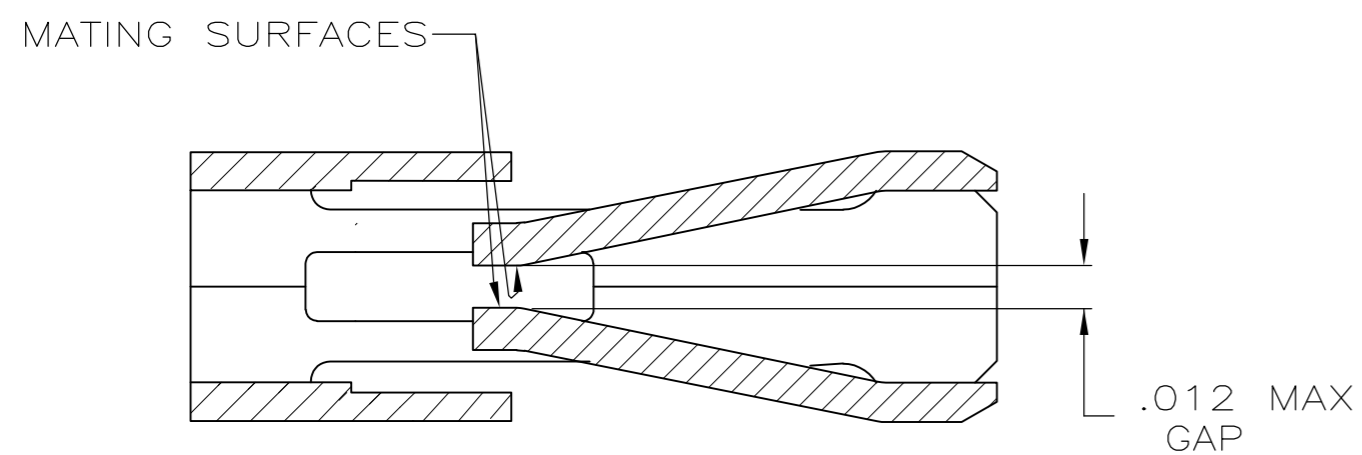
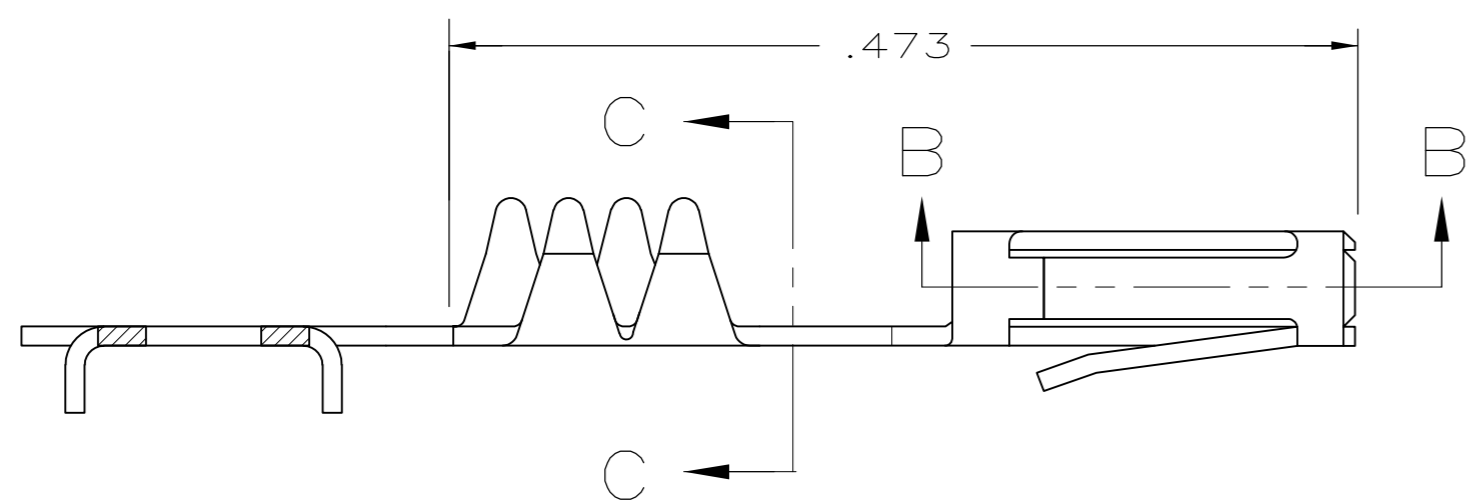

SECTION B-B
SCALE 20:1

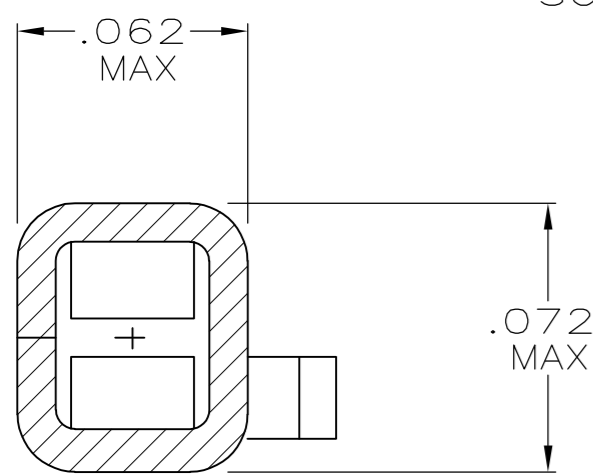

SECTION A-A
SCALE 20:1

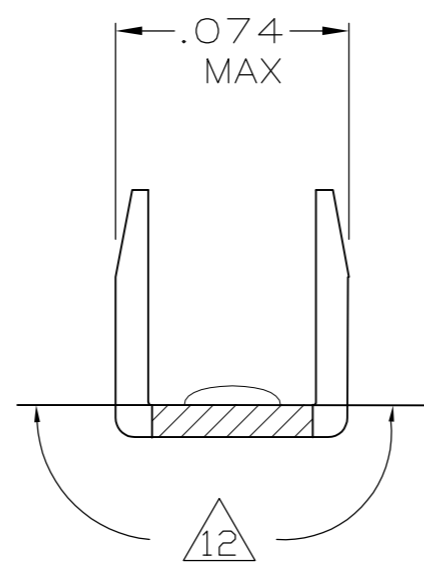

SECTION C-C
SCALE 20:1

SEE NOTES ON SHEET 2

SUPSD BY 487406-2

11	12	2-487406-6
10	12	2-487406-4
9	12	2-487406-3
8	12	2-487406-2
7		1-487406-0
6		487406-9
4		487406-4
3		487406-3
2		487406-2
1		487406-1
FINISH		PART NUMBER

THIS DRAWING IS A CONTROLLED DOCUMENT.		DWN 11-10-84 D.DOLLYHIGH		
DIMENSIONS: INCHES		CHK 11-10-84 J.COMPTON		
TOLERANCES UNLESS OTHERWISE SPECIFIED:		APVD -	NAME	
0 PLC ± -		PRODUCT SPEC	RECEPTACLE CONTACT, STANDARD PRESSURE	
1 PLC ± -		108-9024	-	
2 PLC ± -		APPLICATION SPEC	-	
3 PLC ± .005		114-16015	SIZE	CAGE CODE
4 PLC ± -		WEIGHT -	A2	00779
ANGLES ± -		CUSTOMER DRAWING	DRAWING NO	RESTRICTED TO
FINISH SEE TABLE		SCALE 10:1	C=487406	-
MATERIAL PHOSPHOR BRONZE		SHEET 1 of 2	REV U2	

THIS DRAWING IS UNPUBLISHED. RELEASED FOR PUBLICATION
 © COPYRIGHT - By - ALL RIGHTS RESERVED.

LOC	DIST	REVISIONS					
GP	00	P	LTR	DESCRIPTION	DATE	DWN	APVD
		-	-	SEE SHEET 1	-	-	-

- 1 PREPLATED WITH NICKEL UNDERPLATE .000050 THK ON ENTIRE CONTACT WITH GOLD .000015 THK ON MATING AREA AND PLATED WITH BRIGHT TIN-LEAD .000100 THK IN CRIMP AREA,
-OR-
NICKEL .000050 MIN THK UNDERPLATE ON ENTIRE CONTACT, GOLD FLASH OVER PALLADIUM-NICKEL, .000015 MIN TOTAL THK ON MATING SURFACES AND BRIGHT TIN/LEAD .000100 MIN THK IN CRIMP AREA.
- 2 PREPLATED WITH NICKEL UNDERPLATE .000050 THK ON ENTIRE CONTACT WITH GOLD .000030 THK ON MATING AREA AND PLATED WITH BRIGHT TIN-LEAD .000100 THK IN CRIMP AREA,
-OR-
NICKEL .000050 MIN THK UNDERPLATE ON ENTIRE CONTACT, GOLD FLASH OVER PALLADIUM-NICKEL, .000030 MIN TOTAL THK ON MATING AREA AND BRIGHT TIN/LEAD .000100 MIN THK ON CRIMP AREA.
- 3 PREPLATED WITH NICKEL UNDERPLATE .000050 THK ON ENTIRE CONTACT WITH GOLD .000050 THK ON MATING AREA AND PLATED WITH BRIGHT TIN-LEAD .000100 THK IN CRIMP AREA,
-OR-
NICKEL .000050 MIN THK UNDERPLATE ON ENTIRE CONTACT, GOLD FLASH OVER PALLADIUM-NICKEL, .000050 MIN TOTAL THK ON MATING AREA AND BRIGHT TIN/LEAD .000100 MIN THK ON CRIMP AREA.
- 4 .000100 BRIGHT TIN-LEAD OVER .000050 PRE-PLATED NICKEL UNDERPLATE ON ENTIRE CONTACT.
- 5. MATING POST LENGTH ACCEPTED:
SINGLE ROW HOUSINGS .220-.323
DOUBLE ROW HOUSINGS .235-.323
- 6 PREPLATED WITH NICKEL UNDERPLATE .000050 THK ON ENTIRE CONTACT WITH GOLD .000050 THK ON MATING AREA AND GOLD FLASH OVER ENTIRE CONTACT,
-OR-
NICKEL .000050 MIN THK UNDERPLATE ON ENTIRE CONTACT, GOLD FLASH OVER PALLADIUM-NICKEL, .000050 MIN TOTAL THK ON MATING AREA AND GOLD FLASH OVER ENTIRE CONTACT.
- 7 PREPLATED WITH NICKEL UNDERPLATE .000050 THK ON ENTIRE CONTACT WITH GOLD .000030 THK ON MATING AREA AND PLATED WITH GOLD .000030 THK ON ENTIRE CONTACT EXCEPT .000003 MIN THK PERMISSIBLE ON INTERIOR OF CONTACT BOX EXCLUSIVE OF MATING AREA.
- 8 PREPLATED WITH NICKEL UNDERPLATE .000050 MIN THK ON ENTIRE CONTACT WITH GOLD .000015 MIN THK ON MATING AREA AND PLATED WITH GOLD FLASH IN CRIMP AREA,
-OR-
NICKEL .000050 MIN THK UNDERPLATE ON ENTIRE CONTACT, GOLD FLASH OVER PALLADIUM-NICKEL, .000015 MIN TOTAL THK ON MATING AREA AND GOLD FLASH IN CRIMP AREA.
- 9 PREPLATED WITH NICKEL UNDERPLATE .000050 MIN THK ON ENTIRE CONTACT WITH GOLD .000030 MIN THK ON MATING AREA AND PLATED WITH GOLD FLASH IN CRIMP AREA,
-OR-
NICKEL .000050 MIN THK UNDERPLATE ON ENTIRE CONTACT, GOLD FLASH OVER PALLADIUM-NICKEL, .000030 MIN TOTAL THK ON MATING AREA AND GOLD FLASH IN CRIMP AREA.
- 10 PRE-PLATED WITH NICKEL UNDERPLATE .000050 THICK ON ENTIRE CONTACT WITH GOLD FLASH IN CRIMP AREA AND .000100 MIN TIN ON MATING AREA.
- 11 PRE-PLATED WITH NICKEL UNDERPLATE .000050 THICK ON ENTIRE CONTACT WITH GOLD .000050 THICK ON MATING AREA AND PLATED WITH GOLD FLASH IN CRIMP AREA,
-OR-
NICKEL .000050 MIN THK UNDERPLATE ON ENTIRE CONTACT, GOLD FLASH OVER PALLADIUM-NICKEL, .000050 MIN TOTAL THK ON MATING AREA AND GOLD FLASH IN CRIMP AREA.
- 12 GOLD PLATING MAY OR MAY NOT BE PRESENT ON THE BOTTOM OF THE CRIMP BARREL IN THIS AREA.

487406

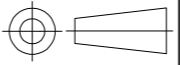
THIS DRAWING IS A CONTROLLED DOCUMENT.		DWN D.DOLLYHIGH 11-10-84	 TE Connectivity				
DIMENSIONS: INCHES		CHK J.COMPTON 11-10-84					
		TOLERANCES UNLESS OTHERWISE SPECIFIED:	NAME				
0 PLC ± - 1 PLC ± - 2 PLC ± - 3 PLC ± .005 4 PLC ± - ANGLES ± -		APVD -	RECEPTACLE CONTACT, STANDARD PRESSURE				
MATERIAL PHOSPHOR BRONZE		FINISH SEE TABLE	PRODUCT SPEC 108-9024	SIZE A2	CAGE CODE 00779	DRAWING NO C=487406	RESTRICTED TO -
		WEIGHT -	CUSTOMER DRAWING		SCALE 10:1	SHEET 2 of 2	REV U2



Компания «ЭлектроПласт» предлагает заключение долгосрочных отношений при поставках импортных электронных компонентов на взаимовыгодных условиях!

Наши преимущества:

- Оперативные поставки широкого спектра электронных компонентов отечественного и импортного производства напрямую от производителей и с крупнейших мировых складов;
- Поставка более 17-ти миллионов наименований электронных компонентов;
- Поставка сложных, дефицитных, либо снятых с производства позиций;
- Оперативные сроки поставки под заказ (от 5 рабочих дней);
- Экспресс доставка в любую точку России;
- Техническая поддержка проекта, помощь в подборе аналогов, поставка прототипов;
- Система менеджмента качества сертифицирована по Международному стандарту ISO 9001;
- Лицензия ФСБ на осуществление работ с использованием сведений, составляющих государственную тайну;
- Поставка специализированных компонентов (Xilinx, Altera, Analog Devices, Intersil, Interpoint, Microsemi, Aeroflex, Peregrine, Syfer, Eurofarad, Texas Instrument, Miteq, Cobham, E2V, MA-COM, Hittite, Mini-Circuits, General Dynamics и др.);

Помимо этого, одним из направлений компании «ЭлектроПласт» является направление «Источники питания». Мы предлагаем Вам помощь Конструкторского отдела:

- Подбор оптимального решения, техническое обоснование при выборе компонента;
- Подбор аналогов;
- Консультации по применению компонента;
- Поставка образцов и прототипов;
- Техническая поддержка проекта;
- Защита от снятия компонента с производства.



Как с нами связаться

Телефон: 8 (812) 309 58 32 (многоканальный)

Факс: 8 (812) 320-02-42

Электронная почта: org@eplast1.ru

Адрес: 198099, г. Санкт-Петербург, ул. Калинина, дом 2, корпус 4, литера А.