

790-046S
Crimp Terminated Cable Plug Connector with
Integrated Banding Porch, Socket Contacts
How To Order

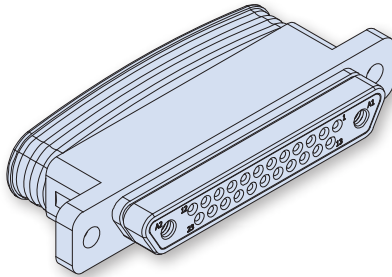

790-046S Cable Receptacles

CRIMP SOCKET CONTACTS, INTEGRATED BANDING PORCH



Rugged, lightweight 790-046S connectors feature machined aluminum shells, fluorosilicone face seals and wire grommets for environmental protection. Contacts are rear-release snap-in crimp. Connectors are supplied with crimp contacts packaged separately. Size #23 signal pins accept up to #22 AWG wire. Size #16 contacts accept #16-18 AWG wire. Size #12 contacts accept #12-14 AWG wire. Size 12 and 16 cavities also accept coaxial contacts purchased separately. Connector shell features an integrated banding porch for attachment of EMI shielding.

HOW TO ORDER			
Sample Part Number			
790-046S	H-10P4	M	B
Base Part Number	Shell Size - Insert Arrangements	Shell Finish	Mounting Hardware
790-046S Cable Receptacle with Crimp Socket Contacts and Integrated Banding Porch	See Table 1 for Available Insert Arrangements. To order a connector without size #16 or #12 power pins, substitute "W" instead of "P" in the insert arrangement. Example: 36P2 is supplied with 2 power pins. 36W2 is supplied less the power pins. See Section B for coaxial contacts purchased separately.	M Electroless Nickel <i>general purpose applications</i> MT Nickel-PTFE 1000 Hour Grey™ <i>maximum corrosion protection and durability (non-reflective grey)</i> ZNU Zinc-Nickel with Black Chromate <i>tactical applications (non-reflective black)</i> Additional shell finishes are listed on page C-9.	B Thru-Hole, No Hardware P Female Jackpost M Hex Socket Head, Jacking MF Hex Socket Head, Floating S Slotted Head, Jacking SF Slotted Head, Floating

SPECIFICATIONS	
Current Rating	#23 5 AMPS, #16 13 A., #12 23 A.
Dielectric Withstanding Voltage	#23 500 VAC RMS, #12 and #16 1800 VAC RMS
Insulation Resistance	5000 megohms minimum
Operating Temperature	-65° C. to +150° C.
Shock	300 g.
Vibration	37 g.

MATERIALS AND FINISHES	
Shell	Aluminum alloy
Contacts	Copper alloy, 50 microinches gold plated
Insulators	Liquid crystal polymer (LCP)
Retention Clips	Beryllium copper alloy
Interfacial Seal, Grommet	Flourosilicone rubber
Hardware	300 series stainless steel

Dimensions in Inches (millimeters) are subject to change without notice.



790-046S Crimp Terminated Cable Plug Connector with Integrated Banding Porch, Socket Contacts Dimensions

Table I Contact Arrangements

Layout	Contact Quantity		Face View
	#23	#16#12	
A-5	5		
B-2P2	2		
B-9	9		
C-13	13		
D-15	15		
D-3P3	3		
D-7P2	5	2	
E-11P2	9	2	
E-19	19		
E-7P3	4	3	
F-15P2	13	2	
F-23	23		
F-5P5	5		
G-33	33		
H-10P4	6	4	
H-29P7	22	7	
H-36P2	34	2	
H-54P2	52	2	
H-5P5		5	
H-66	66		
J-17P4	13	4	
J-25P2	23	2	
J-33	33		
J-7P7	7		
K-27P4	23	4	
K-35P2	33	2	
K-43	43		
K-9P9	9		
L-6P6		6	
L-78	78		
M-102	102		

CROSS-SECTIONAL VIEW OF 790-046S

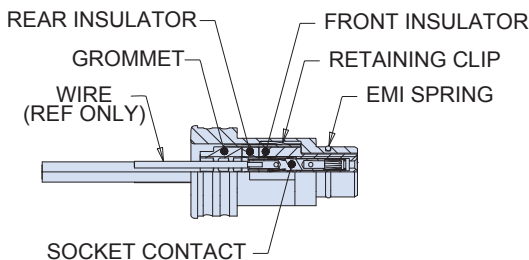

790-046S Dimensions

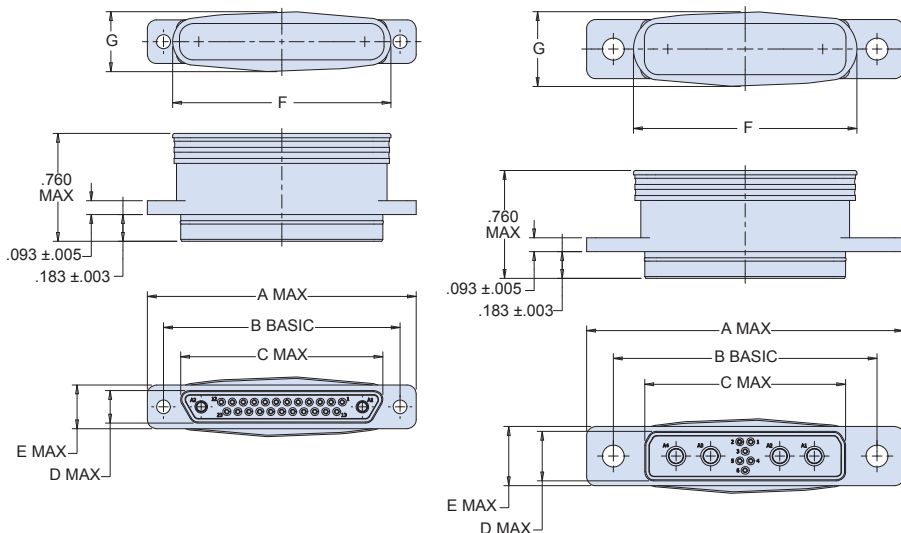

**SHELL SIZES A, B, C, D,
E, F, G, J, K**

SHELL SIZES H, L

790-046S DIMENSIONS

Shell Size	A Max.		B Basic		C Max.		D Max.		E Max.		F Max.		G Max.	
	In.	mm.	In.	mm.	In.	mm.	In.	mm.	In.	mm.	In.	mm.	In.	mm.
A	.785	19.94	.565	14.35	.335	8.51	.233	5.92	.308	7.82	.440	11.18	.360	9.14
B	.935	23.75	.715	18.16	.485	12.32	.233	5.92	.308	7.82	.590	14.99	.370	9.40
C	1.085	27.56	.865	21.97	.635	16.13	.233	5.92	.308	7.82	.740	18.80	.390	9.91
D	1.185	30.10	.965	24.51	.735	18.67	.233	5.92	.308	7.82	.840	21.34	.400	10.16
E	1.335	33.91	1.115	28.32	.885	22.48	.233	5.92	.308	7.82	.990	25.15	.400	10.16
F	1.485	37.72	1.265	32.13	1.035	26.29	.233	5.92	.308	7.82	1.140	28.96	.410	10.41
G	1.435	36.45	1.215	30.86	1.010	25.65	.320	8.13	.395	10.03	1.130	28.70	.490	12.45
H	2.175	55.25	1.800	45.72	1.385	35.18	.349	8.86	.410	10.41	1.525	38.74	.510	12.95
J	1.845	46.86	1.615	41.02	1.390	35.31	.233	5.92	.308	7.82	1.490	37.85	.410	10.41
K	2.240	56.90	2.015	51.18	1.795	45.59	.233	5.92	.308	7.82	1.890	48.01	.430	10.92
L	2.420	61.47	2.036	51.71	1.623	41.22	.349	8.86	.410	10.41	1.760	44.70	.520	13.21
M	2.575	65.41	2.200	55.88	1.745	44.32	.407	10.34	.470	11.94	1.850	46.99	.615	15.62

Dimensions in Inches (millimeters) are subject to change without notice.



Компания «ЭлектроПласт» предлагает заключение долгосрочных отношений при поставках импортных электронных компонентов на взаимовыгодных условиях!

Наши преимущества:

- Оперативные поставки широкого спектра электронных компонентов отечественного и импортного производства напрямую от производителей и с крупнейших мировых складов;
- Поставка более 17-ти миллионов наименований электронных компонентов;
- Поставка сложных, дефицитных, либо снятых с производства позиций;
- Оперативные сроки поставки под заказ (от 5 рабочих дней);
- Экспресс доставка в любую точку России;
- Техническая поддержка проекта, помощь в подборе аналогов, поставка прототипов;
- Система менеджмента качества сертифицирована по Международному стандарту ISO 9001;
- Лицензия ФСБ на осуществление работ с использованием сведений, составляющих государственную тайну;
- Поставка специализированных компонентов (Xilinx, Altera, Analog Devices, Intersil, Interpoint, Microsemi, Aeroflex, Peregrine, Syfer, Eurofarad, Texas Instrument, Miteq, Cobham, E2V, MA-COM, Hittite, Mini-Circuits, General Dynamics и др.);

Помимо этого, одним из направлений компании «ЭлектроПласт» является направление «Источники питания». Мы предлагаем Вам помощь Конструкторского отдела:

- Подбор оптимального решения, техническое обоснование при выборе компонента;
- Подбор аналогов;
- Консультации по применению компонента;
- Поставка образцов и прототипов;
- Техническая поддержка проекта;
- Защита от снятия компонента с производства.



Как с нами связаться

Телефон: 8 (812) 309 58 32 (многоканальный)

Факс: 8 (812) 320-02-42

Электронная почта: org@eplast1.ru

Адрес: 198099, г. Санкт-Петербург, ул. Калинина, дом 2, корпус 4, литера А.