

General Purpose, Pulse and DC Transient Suppression
**F622 Series Metallized Polyester Film,
 5 mm Lead Spacing, 50 – 630 VDC**

Overview

The F622 Series is constructed of metallized stacked polyester film capacitor with radial leads of tinned wire. Radial leads are electrically welded to the contact metal layer on the ends of the capacitor winding. The capacitor is encapsulated in a self-extinguishing material meeting the requirements of UL 94 V-0.

Applications

Typical applications include high performance, high temperature blocking, coupling, decoupling, bypassing and interference suppression in low voltage applications such as automotive. Not for use with the mains.

Benefits

- Voltage range: 50 – 630 VDC
- Capacitance range: 0.001 – 2.2 μ F
- Lead spacing: 5 mm
- Capacitance tolerance: \pm 10%, \pm 20%, \pm 5% on request
- Climatic category: 55/125/56
- Tape and reel packaging in accordance with IEC 60286-2
- RoHS Compliant and lead-free terminations
- Operating temperature range of -55°C to +125°C
- Designed for high performance, high temperature applications

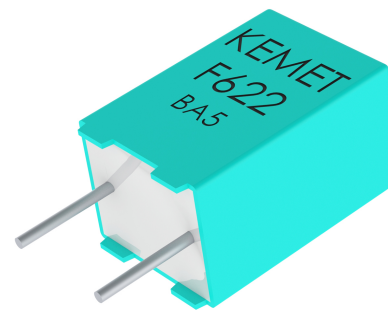

Part Number System

F	622	J	F	104	M	050	C
Capacitor Class	Series	Lead Spacing (mm)	Size Code	Capacitance Code (pF)	Capacitance Tolerance	Rated Voltage (VDC)	Packaging
F = Film	Metallized Polyester	J = 5	See Dimension Table	First two digits represent significant figures. Third digit specifies number of zeros.	J = \pm 5% K = \pm 10% M = \pm 20%	050 = 50 063 = 63 100 = 100 250 = 250 400 = 400 500 = 500 630 = 630	See Ordering Options Table

Ordering Options Table

Lead Spacing Nominal (mm)	Type of Leads and Packaging	Lead Length (mm)	Lead and Packaging Code
5	Standard Lead and Packaging Options		
	Bulk (Bag) – Short Leads	4 +2/-0	C
	Bulk (Bag) – Long Leads	17 +0/-1	A
	Tape & Reel (Standard Reel)	H ₀ = 18.5 +/-0.5	L
	Other Lead and Packaging Options		
	Bulk (Bag) – Max Length Leads	20 +5/-0	ALL0L
	Ammo Pack	H ₀ = 18.5 +/-0.5	R

Dimensions – Millimeters

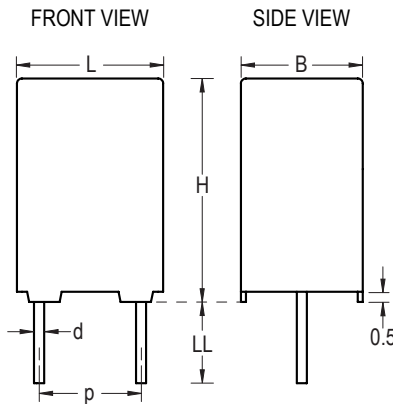

Size Code	p		B		H		L		d	
	Nominal	Tolerance	Nominal	Tolerance	Nominal	Tolerance	Nominal	Tolerance	Nominal	Tolerance
JF	5.0	+/-0.4	2.5	Maximum	6.5	Maximum	7.2	Maximum	0.5	+/-0.05
JG	5.0	+/-0.4	3.5	Maximum	7.5	Maximum	7.2	Maximum	0.5	+/-0.05
JM	5.0	+/-0.4	4.5	Maximum	9.5	Maximum	7.2	Maximum	0.5	+/-0.05
JQ	5.0	+/-0.4	5.0	Maximum	10.0	Maximum	7.2	Maximum	0.5	+/-0.05
JT	5.0	+/-0.4	6.0	Maximum	11.0	Maximum	7.2	Maximum	0.5	+/-0.05

Note: See Ordering Options Table for lead length (LL) options.

Performance Characteristics

Capacitance Tolerance	±20%, ±10%, ±5% on request			
Category Temperature Range	-55°C to 125°C			
Voltage Derating	Above +85°C DC and AC voltage derating is 1.25%/°C			
Rated Temperature	+85°C			
Climatic Category	-55 to +125°C			
	Average relative humidity ≤ 75%			
	RH = 95% for 30 days per year			
	RH = 85% for further days limited by average value per year			
Test Voltage	1.6 x V _R VDC for 2 seconds			
Capacitance Drift	Maximum 3% after a 2 year storage period at a temperature of +10°C to +40°C and a relative humidity of 40% to 60%			
Reliability	Operational life > 200,000 hours			
	Failure rate < 3 FIT, T = +40°C, V = 0.5 x V _R			
	Failure criteria: open circuit, short circuit, cap change > 10%, DF 2 times the catalog limits, IR < 50 MΩ			
Maximum Pulse Steepness	dV/dt according to Table 1. For peak to peak voltages lower than rated voltage (V _{pp} < V _R), the specified dV/dt can be multiplied by the factor V _R /V _{pp} .			
Temperature Coefficient	+400 (±200) ppm/°C at 1 kHz			
Self Inductance	Approximately 6 nH/cm for the total length of capacitor winding and the leads			
Dissipation Factor tanδ	Maximum Values at +23°C			
		C ≤ 0.1 μF	0.1 μF < C ≤ 1.0 μF	C > 1.0 μF
	1 kHz	0.8%	0.8%	0.8%
	10 kHz	1.2%	1.2%	1.5%
	100 kHz	2.5%		
Insulation Resistance	Measured at +20°C, according to IEC 60384-2			
	Minimum Values Between Terminals			
		C ≤ 0.33 μF	C > 0.33 μF and < 1 μF	C > 1.0 μF
	V _R ≤ 100 VDC	15,000 MΩ	5,000 MΩ • μF	1,000 MΩ • μF
	V _R > 100 VDC	30,000 MΩ	10,000 MΩ • μF	

Maximum Voltage (V_{rms}) vs. Frequency (Sinusoidal Waveform/ $T \leq 40^\circ\text{C}$)

Lead Spacing 5 mm

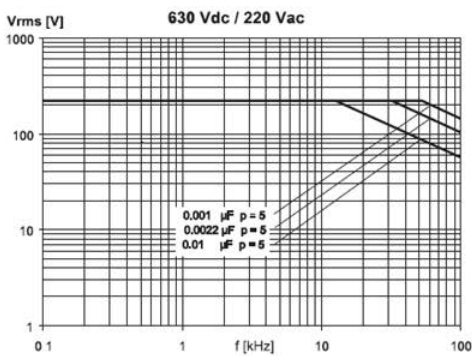
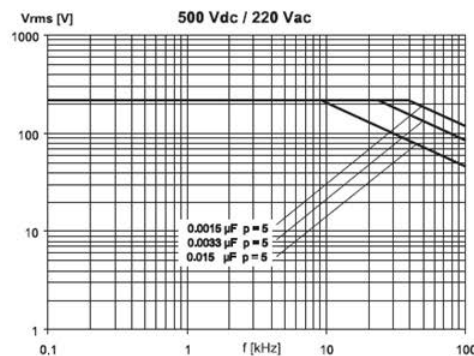
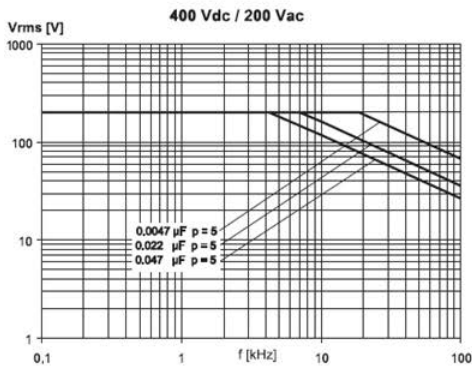
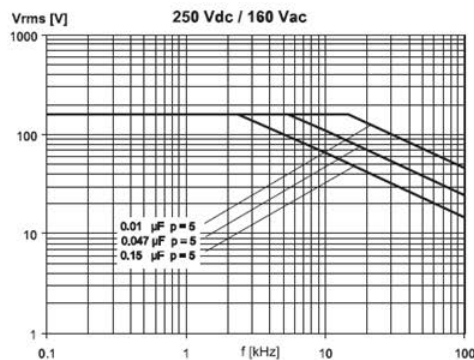
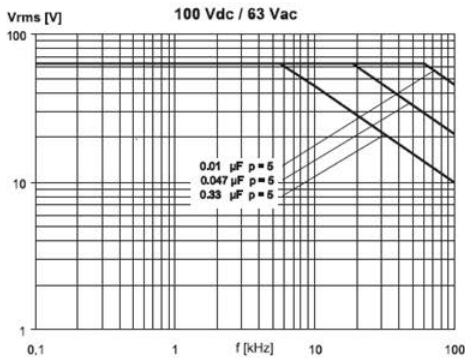
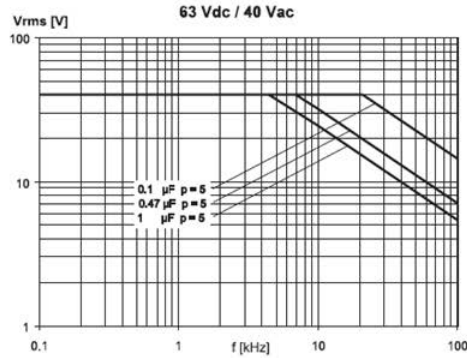
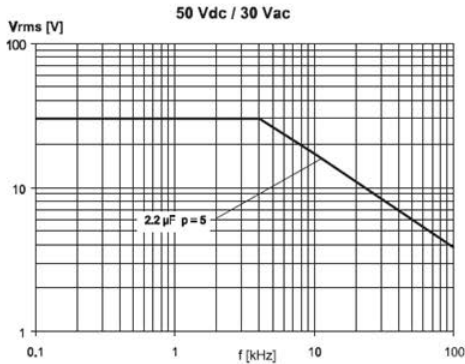

Maximum Current (I_{rms}) vs. Frequency (Sinusoidal Waveform/ $T \leq 40^\circ\text{C}$)

Lead Spacing 5 mm

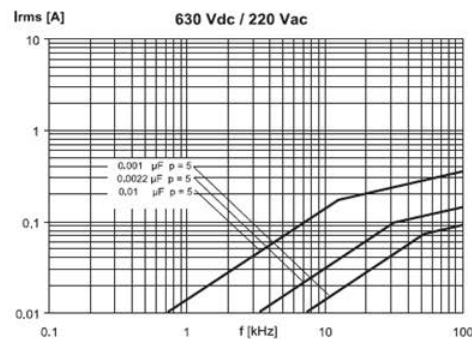
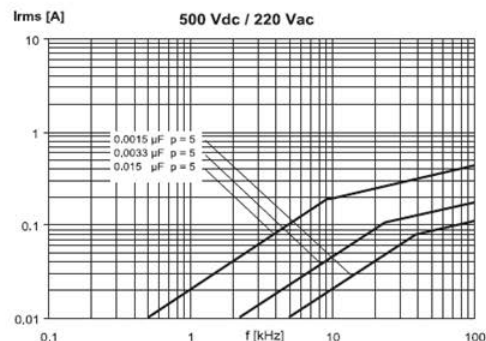
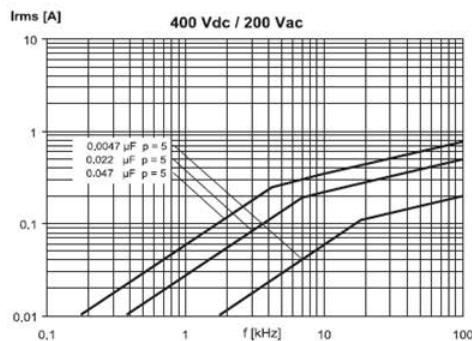
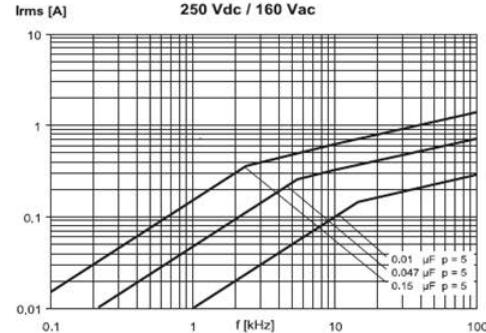
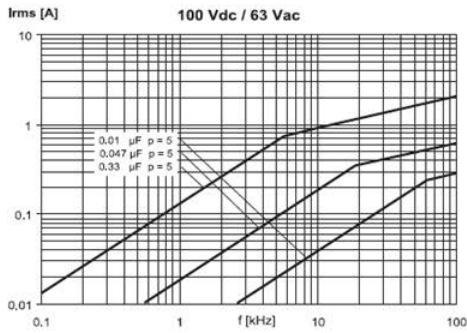
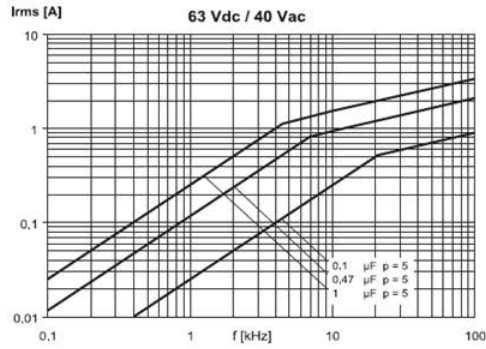
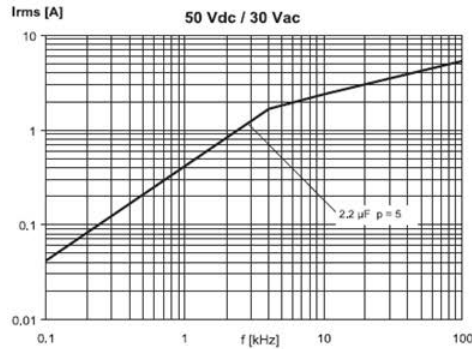

Environmental Test Data

Damp Heat Test	Test Conditions	T = +40°C, RH = 93%, t = 56 days
	Test Criteria	$\Delta C/C \leq \pm 5\%$ $\Delta \tan\delta \leq 0.005$ (1 kHz) IR after test 0.5 x IR minimum
Endurance Test	Test Conditions	T = +100°C, U = 1.25 x (0.8 x U _R)
	Test Criteria	t = 2,000 hours $\Delta C/C \leq \pm 5\%$ $\Delta \tan\delta \leq 0.005$ (1 kHz) $\Delta \tan\delta \leq 0.010$ (100 kHz) IR after test 0.5 x IR minimum

Environmental Compliance

All KEMET MKT capacitors are RoHS Compliant and Halogen Free.



Table 1 – Ratings & Part Number Reference

VDC	VAC	Capacitance Value (µF)	Size Code	Max Dimensions in mm			Lead Spacing (p)	dV/dt (V/µs)	Part Number
				B	H	L			
50	30	2.2	JT	6.0	11.0	7.2	5.0	200	F622JT225(1)050(2)
63	40	0.10	JF	2.5	6.5	7.2	5.0	250	F622JF104(1)063(2)
63	40	0.12	JF	2.5	6.5	7.2	5.0	250	F622JF124(1)063(2)
63	40	0.15	JF	2.5	6.5	7.2	5.0	250	F622JF154(1)063(2)
63	40	0.18	JF	2.5	6.5	7.2	5.0	250	F622JF184(1)063(2)
63	40	0.22	JF	2.5	6.5	7.2	5.0	250	F622JF224(1)063(2)
63	40	0.27	JG	3.5	7.5	7.2	5.0	250	F622JG274(1)063(2)
63	40	0.33	JG	3.5	7.5	7.2	5.0	250	F622JG334(1)063(2)
63	40	0.39	JG	3.5	7.5	7.2	5.0	250	F622JG394(1)063(2)
63	40	0.47	JG	3.5	7.5	7.2	5.0	250	F622JG474(1)063(2)
63	40	0.56	JM	4.5	9.5	7.2	5.0	250	F622JM564(1)063(2)
63	40	0.68	JM	4.5	9.5	7.2	5.0	250	F622JM684(1)063(2)
63	40	0.82	JM	4.5	9.5	7.2	5.0	250	F622JM824(1)063(2)
63	40	1.0	JQ	5.0	10.0	7.2	5.0	250	F622JQ105(1)063(2)
63	40	1.2	JT	6.0	11.0	7.2	5.0	250	F622JT125(1)063(2)
63	40	1.5	JT	6.0	11.0	7.2	5.0	250	F622JT155(1)063(2)
100	63	0.0047	JF	2.5	6.5	7.2	5.0	300	F622JF472(1)100(2)
100	63	0.0056	JF	2.5	6.5	7.2	5.0	300	F622JF562(1)100(2)
100	63	0.0068	JF	2.5	6.5	7.2	5.0	300	F622JF682(1)100(2)
100	63	0.0082	JF	2.5	6.5	7.2	5.0	300	F622JF822(1)100(2)
100	63	0.010	JF	2.5	6.5	7.2	5.0	300	F622JF103(1)100(2)
100	63	0.012	JF	2.5	6.5	7.2	5.0	300	F622JF123(1)100(2)
100	63	0.015	JF	2.5	6.5	7.2	5.0	300	F622JF153(1)100(2)
100	63	0.018	JF	2.5	6.5	7.2	5.0	300	F622JF183(1)100(2)
100	63	0.022	JF	2.5	6.5	7.2	5.0	300	F622JF223(1)100(2)
100	63	0.027	JF	2.5	6.5	7.2	5.0	300	F622JF273(1)100(2)
100	63	0.033	JF	2.5	6.5	7.2	5.0	300	F622JF333(1)100(2)
100	63	0.039	JF	2.5	6.5	7.2	5.0	300	F622JF393(1)100(2)
100	63	0.047	JF	2.5	6.5	7.2	5.0	300	F622JF473(1)100(2)
100	63	0.056	JF	2.5	6.5	7.2	5.0	300	F622JF563(1)100(2)
100	63	0.068	JF	2.5	6.5	7.2	5.0	300	F622JF683(1)100(2)
100	63	0.082	JG	3.5	7.5	7.2	5.0	300	F622JG823(1)100(2)
100	63	0.10	JG	3.5	7.5	7.2	5.0	300	F622JG104(1)100(2)
100	63	0.12	JM	4.5	9.5	7.2	5.0	300	F622JM124(1)100(2)
100	63	0.15	JM	4.5	9.5	7.2	5.0	300	F622JM154(1)100(2)
100	63	0.18	JM	4.5	9.5	7.2	5.0	300	F622JM184(1)100(2)
100	63	0.22	JQ	5.0	10.0	7.2	5.0	300	F622JQ224(1)100(2)
100	63	0.27	JT	6.0	11.0	7.2	5.0	300	F622JT274(1)100(2)
100	63	0.33	JT	6.0	11.0	7.2	5.0	300	F622JT334(1)100(2)
100	63	0.39	JT	6.0	11.0	7.2	5.0	300	F622JT394(1)100(2)
100	63	0.47	JT	6.0	11.0	7.2	5.0	300	F622JT474(1)100(2)
250	160	0.0010	JF	2.5	6.5	7.2	5.0	400	F622JF102(1)250(2)
250	160	0.0012	JF	2.5	6.5	7.2	5.0	400	F622JF122(1)250(2)
250	160	0.0015	JF	2.5	6.5	7.2	5.0	400	F622JF152(1)250(2)
250	160	0.0018	JF	2.5	6.5	7.2	5.0	400	F622JF182(1)250(2)
250	160	0.0022	JF	2.5	6.5	7.2	5.0	400	F622JF222(1)250(2)
250	160	0.0027	JF	2.5	6.5	7.2	5.0	400	F622JF272(1)250(2)
250	160	0.0033	JF	2.5	6.5	7.2	5.0	400	F622JF332(1)250(2)
250	160	0.0039	JF	2.5	6.5	7.2	5.0	400	F622JF392(1)250(2)
250	160	0.0047	JF	2.5	6.5	7.2	5.0	400	F622JF472(1)250(2)
250	160	0.0056	JF	2.5	6.5	7.2	5.0	400	F622JF562(1)250(2)
250	160	0.0068	JF	2.5	6.5	7.2	5.0	400	F622JF682(1)250(2)
250	160	0.082	JF	2.5	6.5	7.2	5.0	400	F622JF823(1)250(2)
250	160	0.010	JF	2.5	6.5	7.2	5.0	400	F622JF103(1)250(2)
250	160	0.012	JF	2.5	6.5	7.2	5.0	400	F622JF123(1)250(2)
250	160	0.015	JF	2.5	6.5	7.2	5.0	400	F622JF153(1)250(2)
250	160	0.018	JF	2.5	6.5	7.2	5.0	400	F622JF183(1)250(2)
250	160	0.022	JG	3.5	7.5	7.2	5.0	400	F622JG223(1)250(2)
250	160	0.027	JG	3.5	7.5	7.2	5.0	400	F622JG273(1)250(2)
VDC	VAC	Capacitance Value (µF)	Size Code	B (mm)	H (mm)	L (mm)	Lead Spacing (p)	dV/dt (V/µs)	Part Number

(1) K = ±10%, M = ±20%, J = ±5% on request.

(2) Insert lead and packaging code. See table for available options.

Table 1 – Ratings & Part Number Reference cont'd

VDC	VAC	Capacitance Value (µF)	Size Code	Max Dimensions in mm			Lead Spacing (p)	dV/dt (V/µs)	Part Number
				B	H	L			
250	160	0.033	JG	3.5	7.5	7.2	5.0	400	F622JG333(1)250(2)
250	160	0.039	JG	3.5	7.5	7.2	5.0	400	F622JG393(1)250(2)
250	160	0.047	JM	4.5	9.5	7.2	5.0	400	F622JM473(1)250(2)
250	160	0.056	JM	4.5	9.5	7.2	5.0	400	F622JM563(1)250(2)
250	160	0.068	JM	4.5	9.5	7.2	5.0	400	F622JM683(1)250(2)
250	160	0.082	JM	4.5	9.5	7.2	5.0	400	F622JM823(1)250(2)
250	160	0.10	JQ	5.0	10.0	7.2	5.0	400	F622JQ104(1)250(2)
250	160	0.12	JT	6.0	11.0	7.2	5.0	400	F622JT124(1)250(2)
250	160	0.15	JT	6.0	11.0	7.2	5.0	400	F622JT154(1)250(2)
400	200	0.0010	JF	2.5	6.5	7.2	5.0	600	F622JF102(1)400(2)
400	200	0.0012	JF	2.5	6.5	7.2	5.0	600	F622JF122(1)400(2)
400	200	0.0015	JF	2.5	6.5	7.2	5.0	600	F622JF152(1)400(2)
400	200	0.0018	JF	2.5	6.5	7.2	5.0	600	F622JF182(1)400(2)
400	200	0.0022	JF	2.5	6.5	7.2	5.0	600	F622JF222(1)400(2)
400	200	0.0027	JF	2.5	6.5	7.2	5.0	600	F622JF272(1)400(2)
400	200	0.0033	JF	2.5	6.5	7.2	5.0	600	F622JF332(1)400(2)
400	200	0.0039	JF	2.5	6.5	7.2	5.0	600	F622JF392(1)400(2)
400	200	0.0047	JF	2.5	6.5	7.2	5.0	600	F622JF472(1)400(2)
400	200	0.0056	JG	3.5	7.5	7.2	5.0	600	F622JG562(1)400(2)
400	200	0.0068	JG	3.5	7.5	7.2	5.0	600	F622JG682(1)400(2)
400	200	0.0082	JG	3.5	7.5	7.2	5.0	600	F622JG822(1)400(2)
400	200	0.010	JG	3.5	7.5	7.2	5.0	600	F622JG103(1)400(2)
400	200	0.012	JG	3.5	7.5	7.2	5.0	600	F622JG123(1)400(2)
400	200	0.015	JG	3.5	7.5	7.2	5.0	600	F622JG153(1)400(2)
400	200	0.018	JM	4.5	9.5	7.2	5.0	600	F622JM183(1)400(2)
400	200	0.022	JM	4.5	9.5	7.2	5.0	600	F622JM223(1)400(2)
400	200	0.027	JM	4.5	9.5	7.2	5.0	600	F622JM273(1)400(2)
400	200	0.033	JQ	5.0	10.0	7.2	5.0	600	F622JQ333(1)400(2)
400	200	0.039	JQ	5.0	10.0	7.2	5.0	600	F622JQ393(1)400(2)
400	200	0.047	JT	6.0	11.0	7.2	5.0	600	F622JT473(1)400(2)
400	200	0.056	JT	6.0	11.0	7.2	5.0	600	F622JT563(1)400(2)
500	220	0.0010	JF	2.5	6.5	7.2	5.0	700	F622JF102(1)500(2)
500	220	0.0012	JF	2.5	6.5	7.2	5.0	700	F622JF122(1)500(2)
500	220	0.0015	JF	2.5	6.5	7.2	5.0	700	F622JF152(1)500(2)
500	220	0.0018	JF	2.5	6.5	7.2	5.0	700	F622JF182(1)500(2)
500	220	0.0022	JG	3.5	7.5	7.2	5.0	700	F622JG222(1)500(2)
500	220	0.0027	JG	3.5	7.5	7.2	5.0	700	F622JG272(1)500(2)
500	220	0.0033	JG	3.5	7.5	7.2	5.0	700	F622JG332(1)500(2)
500	220	0.0039	JG	3.5	7.5	7.2	5.0	700	F622JG392(1)500(2)
500	220	0.0047	JG	3.5	7.5	7.2	5.0	700	F622JG472(1)500(2)
500	220	0.0056	JM	4.5	9.5	7.2	5.0	700	F622JM562(1)500(2)
500	220	0.0068	JM	4.5	9.5	7.2	5.0	700	F622JM682(1)500(2)
500	220	0.0082	JM	4.5	9.5	7.2	5.0	700	F622JM822(1)500(2)
500	220	0.010	JQ	5.0	10.0	7.2	5.0	700	F622JQ103(1)500(2)
500	220	0.012	JT	6.0	11.0	7.2	5.0	700	F622JT123(1)500(2)
500	220	0.015	JT	6.0	11.0	7.2	5.0	700	F622JT153(1)500(2)
630	220	0.0010	JF	2.5	6.5	7.2	5.0	800	F622JF102(1)630(2)
630	220	0.0012	JF	2.5	6.5	7.2	5.0	800	F622JF122(1)630(2)
630	220	0.0015	JG	3.5	7.5	7.2	5.0	800	F622JG152(1)630(2)
630	220	0.0018	JG	3.5	7.5	7.2	5.0	800	F622JG182(1)630(2)
630	220	0.0022	JG	3.5	7.5	7.2	5.0	800	F622JG222(1)630(2)
630	220	0.0027	JG	3.5	7.5	7.2	5.0	800	F622JG272(1)630(2)
630	220	0.0033	JM	4.5	9.5	7.2	5.0	800	F622JM332(1)630(2)
630	220	0.0039	JM	4.5	9.5	7.2	5.0	800	F622JM392(1)630(2)
630	220	0.0047	JM	4.5	9.5	7.2	5.0	800	F622JM472(1)630(2)
630	220	0.0056	JM	4.5	9.5	7.2	5.0	800	F622JM562(1)630(2)
630	220	0.0068	JQ	5.0	10.0	7.2	5.0	800	F622JQ682(1)630(2)
630	220	0.0082	JT	6.0	11	7.2	5.0	800	F622JT822(1)630(2)
630	220	0.010	JT	6.0	11	7.2	5.0	800	F622JT103(1)630(2)
VDC	VAC	Capacitance Value (µF)	Size Code	B (mm)	H (mm)	L (mm)	Lead Spacing (p)	dV/dt (V/µs)	Part Number

(1) K = ±10%, M = ±20%, J = ±5% on request.

(2) Insert lead and packaging code. See table for available options.

Soldering Process

The implementation of the RoHS directive has resulted in the selection of SnAgCu (SAC) alloys or SnCu alloys as primary solder. This has increased the liquidus temperature from that of 183°C for SnPb eutectic alloy to 217 – 221°C for the new alloys. As a result, the heat stress to the components, even in wave soldering, has increased considerably due to higher pre-heat and wave temperatures. Polypropylene capacitors are especially sensitive to heat (the melting point of polypropylene is 160 – 170°C). Wave soldering can be destructive, especially for mechanically small polypropylene capacitors (with lead spacing of 5 mm to 15 mm), and great care has to be taken during soldering. The recommended solder profiles from KEMET should be used. Please consult KEMET with any questions. In general, the wave soldering curve from IEC Publication 61760-1 Edition 2 serves as a solid guideline for successful soldering. Please see Figure 1.

Reflow soldering is not recommended for through-hole film capacitors. Exposing capacitors to a soldering profile in excess of the above the recommended limits may result to degradation or permanent damage to the capacitors.

Do not place the polypropylene capacitor through an adhesive curing oven to cure resin for surface mount components. Insert through-hole parts after the curing of surface mount parts. Consult KEMET to discuss the actual temperature profile in the oven, if through-hole components must pass through the adhesive curing process. A maximum two soldering cycles is recommended. Please allow time for the capacitor surface temperature to return to a normal temperature before the second soldering cycle.

Manual Soldering Recommendations

Following is the recommendation for manual soldering with a soldering iron.

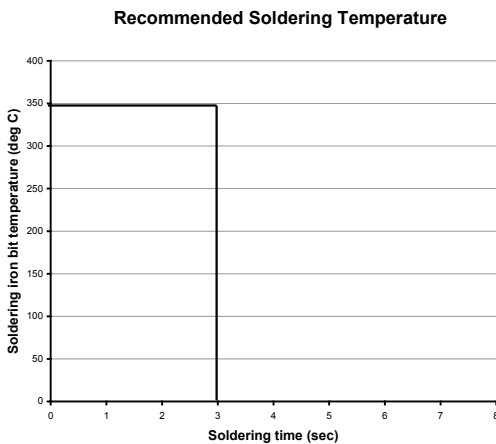

The soldering iron tip temperature should be set at 350°C (+10°C maximum) with the soldering duration not to exceed more than 3 seconds.

Wave Soldering Recommendations

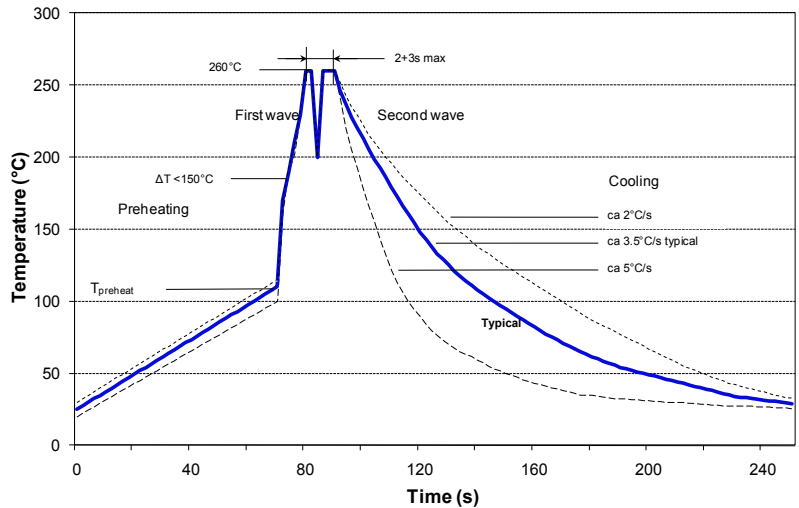

Soldering Process cont'd

Wave Soldering Recommendations cont'd

1. The table indicates the maximum set-up temperature of the soldering process

Figure 1

Dielectric Film Material	Maximum Preheat Temperature			Maximum Peak Soldering Temperature	
	Capacitor Pitch ≤ 10 mm	Capacitor Pitch = 15 mm	Capacitor Pitch > 15 mm	Capacitor Pitch ≤ 15 mm	Capacitor Pitch > 15 mm
Polyester	130°C	130°C	130°C	270°C	270°C
Polypropylene	100°C	110°C	130°C	260°C	270°C
Paper	130°C	130°C	140°C	270°C	270°C
Polyphenylene Sulphide	150°C	150°C	160°C	270°C	270°C

2. The maximum temperature measured inside the capacitor:

Set the temperature so that inside the element the maximum temperature is below the limit:

Dielectric Film Material	Maximum temperature measured inside the element
Polyester	160°C
Polypropylene	110°C
Paper	160°C
Polyphenylene sulphide	160°C

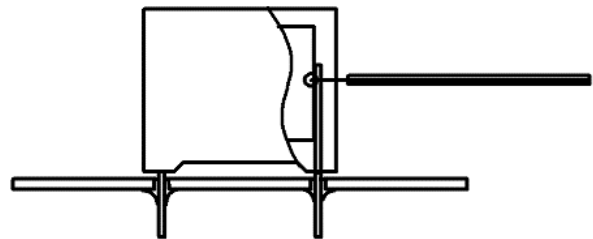

Temperature monitored inside the capacitor.

Selective Soldering Recommendations

Selective dip soldering is a variation of reflow soldering. In this method, the printed circuit board with through-hole components to be soldered is preheated and transported over the solder bath as in normal flow soldering without touching the solder. When the board is over the bath, it is stopped and pre-designed solder pots are lifted from the bath with molten solder only at the places of the selected components, and pressed against the lower surface of the board to solder the components.

The temperature profile for selective soldering is similar to the double wave flow soldering outlined in this document, **however, instead of two baths, there is only one bath with a time from 3 to 10 seconds.** In selective soldering, the risk of overheating is greater than in double wave flow soldering, and great care must be taken so that the parts are not overheated.

Construction

Stacked

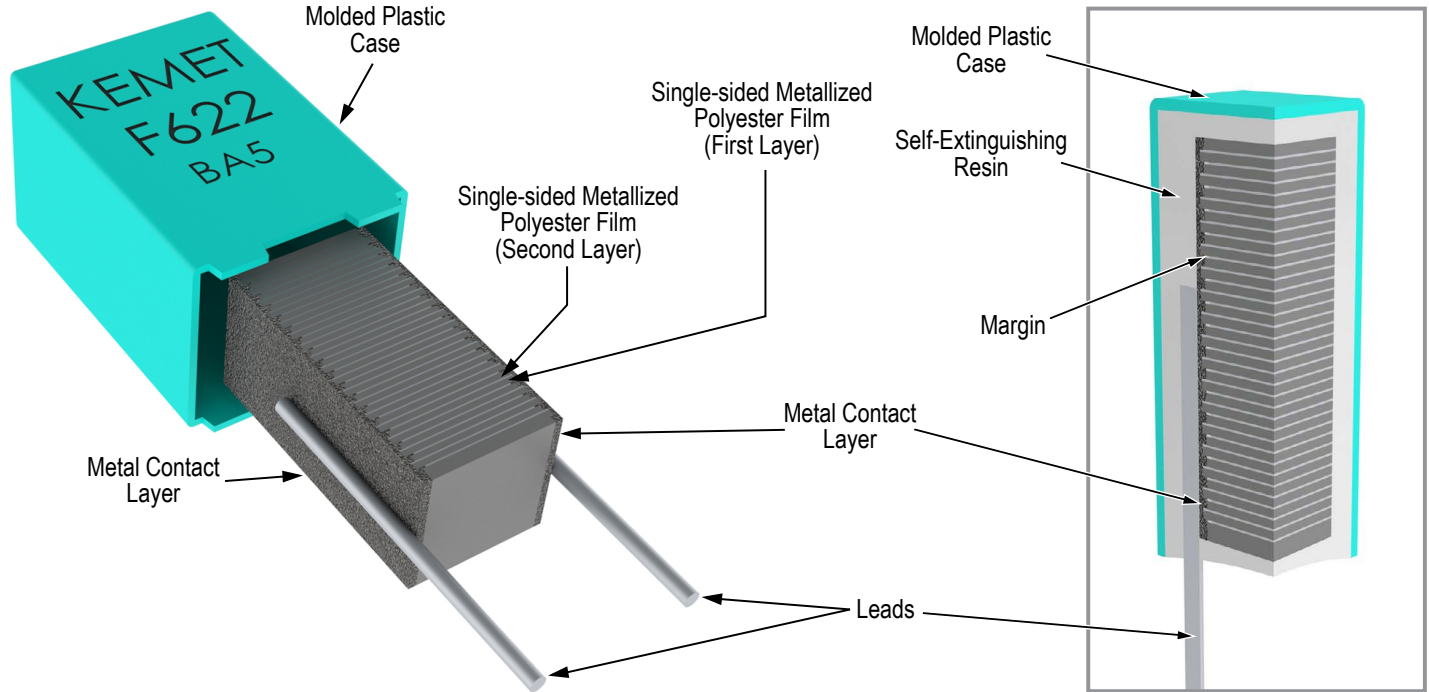

Marking

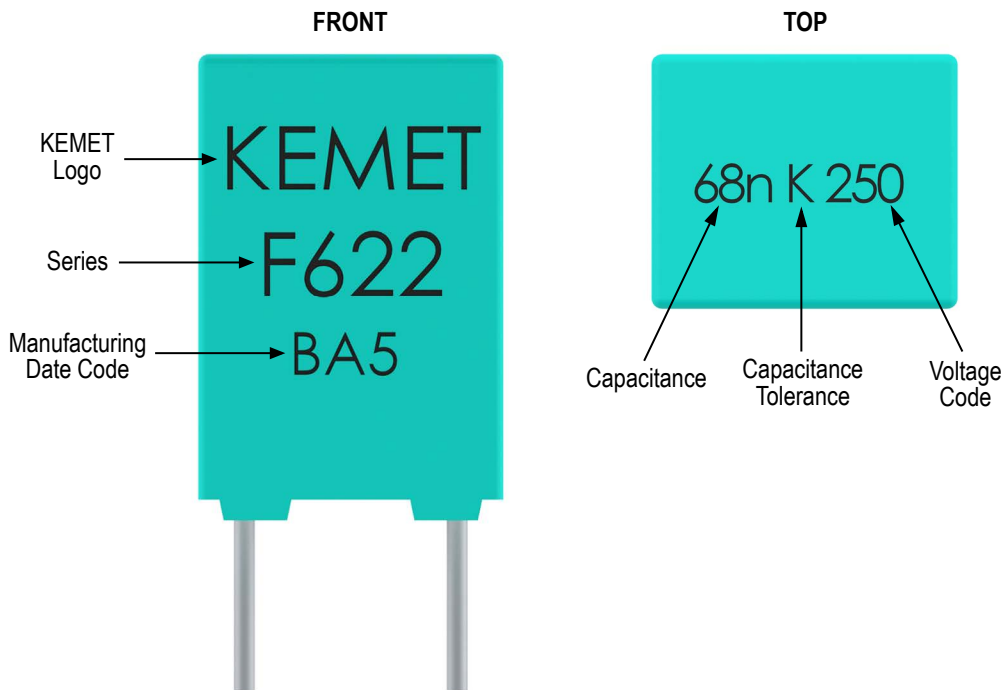

Packaging Quantities

Size Code	Lead Spacing	Thickness (mm)	Height (mm)	Length (mm)	Bulk Short Leads	Bulk Long Leads	Standard Reel ø 355 mm	Ammo
JF	5	2.5	6.5	7.2	3000	4000	2500	3500
JG		3.5	7.5	7.2	2000	3000	1800	2500
JM		4.5	9.5	7.2	1500	2000	1400	1900
JQ		5.0	10.0	7.2	1000	1500	1200	1700
JT		6	11	7.2	2000	1000	1000	1400
JU		7.2	13	7.2	1500	750	800	1150

Lead Taping & Packaging (IEC 60286–2)

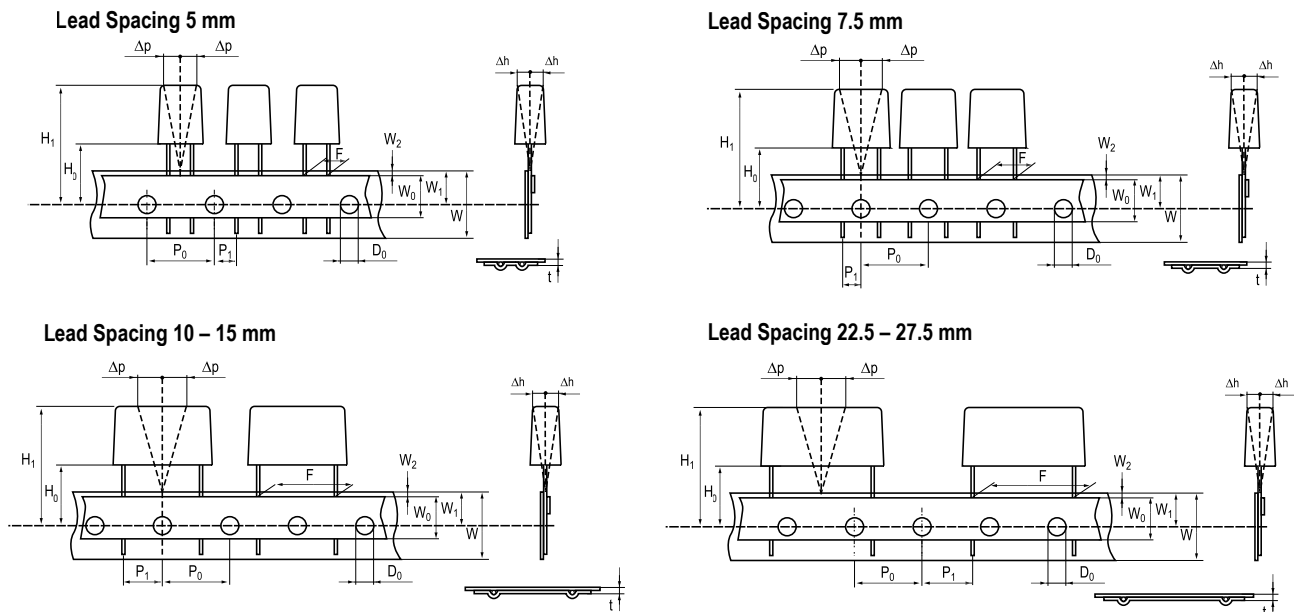

Taping Specification

Dimensions in mm									Standard IEC 60286–2
Lead spacing	+6/-0.1	F	5	7.5	10	15	22.5	27.5	F
Carrier tape width	+1/-0.5	W	18	18	18	18	18	18	18 ^{+1/-0.5}
Hold-down tape width	Minimum	W_0	6	6	9	10	10	10	
Position of sprocket hole	+/-0.5	W_1	9	9	9	9	9	9	9 ^{+0.75/-0.5}
Distance between tapes	Maximum	W_2	3	3	3	3	3	3	3
Sprocket hole diameter	+/-0.2	D_0	4	4	4	4	4	4	4
Feed hole lead spacing	+/-0.2 ⁽¹⁾	P_0 ⁽³⁾	12.7	12.7	12.7	12.7	12.7	12.7	12.7
Distance lead – feed hole	+/-0.7	P_1	3.85	3.75	7.7	5.2	7.8	5.3	P^1
Deviation tape – plane	Maximum	Δp	1.3	1.3	1.3	1.3	1.3	1.3	1.3
Lateral deviation	+/-2	Δh	2	2	2	2	2	2	2
Total thickness	+/-0.2	t	0.7	0.7	0.7	0.7	0.9 ^{MAX}	0.9 ^{MAX}	0.9 ^{MAX}
Sprocket hole/cap body	+/-0.5	H_0 ⁽²⁾	18.5 ^{+/-0.5}	18.5 ^{+/-0.5}	18.5 ^{+/-0.5}	18.5 ^{+/-0.5}	18.5 ^{+/-0.5}	18.5 ^{+/-0.5}	18 ^{+2/-0}

(1) Maximum cumulative feed hole error, 1 mm per 20 parts.

(2) 16.5 mm available on request.

(3) 15 mm available on request ($F \geq 10$ mm).

Lead Taping & Packaging (IEC 60286–2) cont'd

Ammo Specifications

Series	Dimensions (mm)		
	H	W	T
R4x, R4x+R, R7x, RSB	360	340	59
F5A, F5B, F5D			
F6xx, F8xx			
PHExxx, PMExxx, PMRxxx	330	330	50

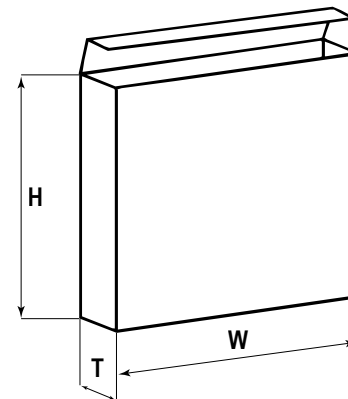

Reel Specifications

Series	Dimensions (mm)		
	D	H	W
R4x, R4x+R, R7x, RSB	355 500	30	55 (Max)
F5A, F5B, F5D		25	
F6xx, F8xx			
PHExxx, PMExxx, PMRxxx	360 500	30	46 (Max)

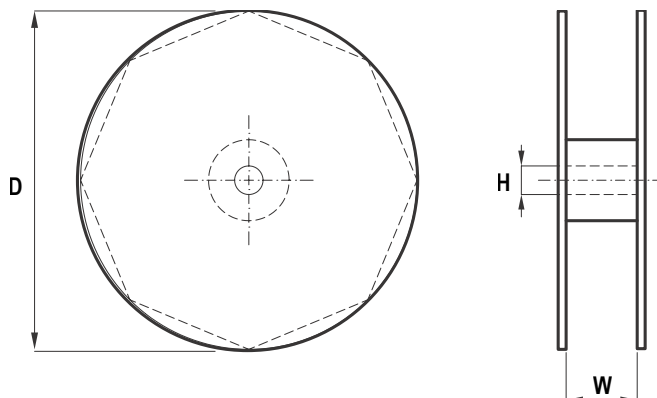

Manufacturing Date Code (IEC–60062)

Y = Year, Z = Month			
Year	Code	Month	Code
2000	M	January	1
2001	N	February	2
2002	P	March	3
2003	R	April	4
2004	S	May	5
2005	T	June	6
2006	U	July	7
2007	V	August	8
2008	W	September	9
2009	X	October	O
2010	A	November	N
2011	B	December	D
2012	C		
2013	D		
2014	E		
2015	F		
2016	H		
2017	J		
2018	K		
2019	L		
2020	M		

KEMET Corporation World Headquarters

2835 KEMET Way
Simpsonville, SC 29681

Mailing Address:
P.O. Box 5928
Greenville, SC 29606

www.kemet.com
Tel: 864-963-6300
Fax: 864-963-6521

Corporate Offices
Fort Lauderdale, FL
Tel: 954-766-2800

North America

Southeast

Lake Mary, FL
Tel: 407-855-8886

Northeast

Wilmington, MA
Tel: 978-658-1663

Central

Novi, MI
Tel: 248-306-9353

West

Milpitas, CA
Tel: 408-433-9950

Mexico

Guadalajara, Jalisco
Tel: 52-33-3123-2141

Europe

Southern Europe

Sasso Marconi, Italy
Tel: 39-051-939111

Skopje, Macedonia
Tel: 389-2-55-14-623

Central Europe

Landsberg, Germany
Tel: 49-8191-3350800

Kamen, Germany
Tel: 49-2307-438110

Northern Europe

Harlow, United Kingdom
Tel: 44-1279-460122

Espoo, Finland
Tel: 358-9-5406-5000

Asia

Northeast Asia

Hong Kong
Tel: 852-2305-1168

Shenzhen, China
Tel: 86-755-2518-1306

Beijing, China
Tel: 86-10-5877-1075

Shanghai, China
Tel: 86-21-6447-0707

Seoul, South Korea
Tel: 82-2-6294-0550

Taipei, Taiwan
Tel: 886-2-27528585

Southeast Asia

Singapore
Tel: 65-6701-8033

Penang, Malaysia
Tel: 60-4-6430200

Bangalore, India
Tel: 91-806-53-76817

Note: KEMET reserves the right to modify minor details of internal and external construction at any time in the interest of product improvement. KEMET does not assume any responsibility for infringement that might result from the use of KEMET Capacitors in potential circuit designs. KEMET is a registered trademark of KEMET Electronics Corporation.

Disclaimer

All product specifications, statements, information and data (collectively, the "Information") in this datasheet are subject to change. The customer is responsible for checking and verifying the extent to which the Information contained in this publication is applicable to an order at the time the order is placed.

All Information given herein is believed to be accurate and reliable, but it is presented without guarantee, warranty, or responsibility of any kind, expressed or implied.

Statements of suitability for certain applications are based on KEMET Electronics Corporation's ("KEMET") knowledge of typical operating conditions for such applications, but are not intended to constitute – and KEMET specifically disclaims – any warranty concerning suitability for a specific customer application or use. The Information is intended for use only by customers who have the requisite experience and capability to determine the correct products for their application. Any technical advice inferred from this Information or otherwise provided by KEMET with reference to the use of KEMET's products is given gratis, and KEMET assumes no obligation or liability for the advice given or results obtained.

Although KEMET designs and manufactures its products to the most stringent quality and safety standards, given the current state of the art, isolated component failures may still occur. Accordingly, customer applications which require a high degree of reliability or safety should employ suitable designs or other safeguards (such as installation of protective circuitry or redundancies) in order to ensure that the failure of an electrical component does not result in a risk of personal injury or property damage.

Although all product-related warnings, cautions and notes must be observed, the customer should not assume that all safety measures are indicated or that other measures may not be required.



Компания «ЭлектроПласт» предлагает заключение долгосрочных отношений при поставках импортных электронных компонентов на взаимовыгодных условиях!

Наши преимущества:

- Оперативные поставки широкого спектра электронных компонентов отечественного и импортного производства напрямую от производителей и с крупнейших мировых складов;
- Поставка более 17-ти миллионов наименований электронных компонентов;
- Поставка сложных, дефицитных, либо снятых с производства позиций;
- Оперативные сроки поставки под заказ (от 5 рабочих дней);
- Экспресс доставка в любую точку России;
- Техническая поддержка проекта, помощь в подборе аналогов, поставка прототипов;
- Система менеджмента качества сертифицирована по Международному стандарту ISO 9001;
- Лицензия ФСБ на осуществление работ с использованием сведений, составляющих государственную тайну;
- Поставка специализированных компонентов (Xilinx, Altera, Analog Devices, Intersil, Interpoint, Microsemi, Aeroflex, Peregrine, Syfer, Eurofarad, Texas Instrument, Miteq, Cobham, E2V, MA-COM, Hittite, Mini-Circuits, General Dynamics и др.);

Помимо этого, одним из направлений компании «ЭлектроПласт» является направление «Источники питания». Мы предлагаем Вам помощь Конструкторского отдела:

- Подбор оптимального решения, техническое обоснование при выборе компонента;
- Подбор аналогов;
- Консультации по применению компонента;
- Поставка образцов и прототипов;
- Техническая поддержка проекта;
- Защита от снятия компонента с производства.



Как с нами связаться

Телефон: 8 (812) 309 58 32 (многоканальный)

Факс: 8 (812) 320-02-42

Электронная почта: org@eplast1.ru

Адрес: 198099, г. Санкт-Петербург, ул. Калинина, дом 2, корпус 4, литера А.