

SPECIFICATION CONTROL DRAWING

55A0211

TITLE	RADIATION-CROSSLINKED, MODIFIED, ETFE-INSULATED, TIN-COATED COPPER, MEDIUM WEIGHT	Date	6-21-04	Revision	H
-------	---	------	---------	----------	---

This specification sheet forms a part of the latest issue of Raychem Specification 55A

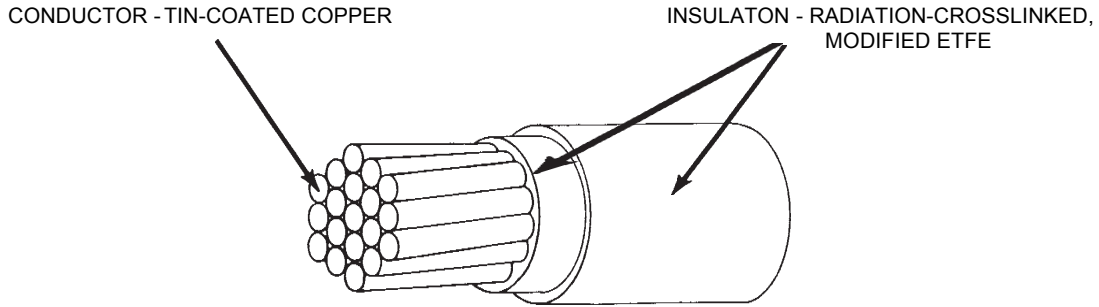

TABLE I. CONSTRUCTION DETAILS

PART NUMBER 1/	WIRE SIZE (AWG)	CONDUCTOR STRANDING (number x AWG)	DIAMETER OF STRANDED CONDUCTOR (in.)		FINISHED WIRE		
			MINIMUM	MAXIMUM	MAXIMUM RESISTANCE AT 20°C (ohms/1000 ft)	DIAMETER (in.)	MAXIMUM WEIGHT (lb/1000 ft)
55A0211-26-*	26	19 x 38	.018	.020	41.3	.034 ± .002	1.5
55A0211-24-*	24	19 x 36	.023	.025	26.2	.039 ± .002	2.1
55A0211-22-*	22	19 x 34	.029	.031	16.2	.045 ± .002	3.0
55A0211-20-*	20	19 x 32	.037	.039	9.88	.053 ± .003	4.6
55A0211-18-*	18	19 x 30	.046	.049	6.23	.063 ± .003	6.8
55A0211-16-*	16	19 x 29	.052	.055	4.81	.071 ± .003	8.7
55A0211-14-*	14	19 x 27	.065	.069	3.06	.088 ± .004	13.4
55A0211-12-*	12	37 x 28	.084	.089	2.02	.106 ± .004	20.2
55A0211-10-*	10	37 x 26	.106	.113	1.26	.131 ± .006	32.0
55A0211- 8-*	8	133 x 29	.158	.166	.701	.190 ± .008	58.0
55A0211- 6-*	6	133 x 27	.198	.205	.445	.238 ± .010	92.0

TABLE II. PERFORMANCE DETAILS

PART NUMBER 1/	BEND TESTING			
	MANDREL DIAMETER (inch) (± 3%)		WEIGHT (lb) (± 3%)	
	IMMERSION, LIFE CYCLE AND ACCELERATED AGING	COLD BEND	IMMERSION, LIFE CYCLE AND ACCELERATED AGING	COLD BEND
55A0211-26-*	.375	1.00	.125	1.50
55A0211-24-*	.375	1.00	.250	2.00
55A0211-22-*	.500	1.00	.375	2.00
55A0211-20-*	.500	1.00	.500	2.00
55A0211-18-*	.500	1.50	.500	2.00
55A0211-16-*	.750	1.50	.750	3.00
55A0211-14-*	1.00	2.00	1.00	4.00
55A0211-12-*	1.50	2.00	1.50	4.00
55A0211-10-*	2.00	3.00	1.50	4.00
55A0211- 8-*	3.00	4.00	2.00	5.00
55A0211- 6-*	4.00	5.00	2.00	6.00

Users should evaluate the suitability of this product for their application. Specifications are subject to change without notice. Tyco Electronics also reserves the right to make changes in materials or processing, which do not affect compliance with any specification, without notification to Buyer.

1/ COLORS AND COLOR CODE DESIGNATORS SHALL BE IN ACCORDANCE WITH MIL-STD-681. OTHER CODES AND SUFFIXES MAY BE ADDED TO THE PART NUMBER, AS NECESSARY, TO CAPTURE ANY ADDITIONAL REQUIREMENTS IMPOSED BY THE PURCHASE ORDER.



Raychem Wire & Cable
501 Oakside Avenue
Redwood City, CA 94063-3800
Phone: 1-800-227-8816
Fax: 1-650-361-6297

DIMENSIONS ARE IN INCHES, AND UNLESS OTHERWISE DESIGNATED ARE NOMINAL.
THIS SPECIFICATION SHEET TAKES PRECEDENCE OVER DOCUMENTS REFERENCED HEREIN.
REFERENCED DOCUMENTS SHALL BE OF THE ISSUE IN EFFECT ON DATE OF INVITATION FOR BID.

WIRE RATINGS AND ADDITIONAL REQUIREMENTS

TEMPERATURE RATING: 150°C,

Maximum continuous conductor temperature

VOLTAGE RATING: 600 volts (rms) at sea level

ACCELERATED AGING: 300 ± 3°C for 7 hours

BLOCKING: 200 ± 3°C for 24 hours

COLOR: white preferred

CONCENTRICITY: 70% (minimum)

FLAMMABILITY: Procedure 1, 3 seconds (maximum); 3 in. (maximum); no flaming of facial tissue.

HUMIDITY RESISTANCE: Insulation Resistance,

5000 megohms for 1000 ft. (minimum) for AWG 26-10,

3000 megohms for 1000 ft. (minimum) for AWG 8-6

IDENTIFICATION AND COLOR STRIPING DURABILITY: 125 cycles (250 strokes) (minimum), 500 g weight

INSULATION ELONGATION AND TENSILE STRENGTH:

Total Insulation,

Tensile strength, 5000 lbf/in² (minimum)

Elongation, 50% (minimum) for total insulation

INSULATION FLAWS:

Primary Insulation,

Spark test, 1.5 kV (rms)

Impulse Dielectric Test, 6.0 kV (peak)

Finished Wire,

Spark Test, 3.0 kV (rms)

Impulse Dielectric Test, 8.0 kV (peak)

INSULATION RESISTANCE:

5000 megohms for 1000 ft (minimum), for AWG 26 - 10

3000 megohms for 1000 ft. (minimum) for AWG 8-6

INSULATION THICKNESS: 0.006 in. (minimum), (total insulation)

LIFE CYCLE: 200 ± 3°C for 500 hours

LOW TEMPERATURE-COLD BEND: -65 ± 3°C for 4 hours

SHRINKAGE: 200 ± 3°C, for 6 hours, 0.125 in. (maximum) in 12 in.

SMOKE TEST: 200 ± 2°C. No visible smoke

SURFACE RESISTANCE: 500 Megohms-in. (minimum), both readings

THERMAL SHOCK RESISTANCE:

AWG 26-12, 150 ± 3°C, 0.060 in. (maximum)

AWG 10- 8, 150 ± 3°C, 0.100 in. (maximum)

AWG 6, 150 ± 3°C, 0.125 in. (maximum)

VOLTAGE WITHSTAND (Post Environmental): 2500 volts (rms), 60 Hz

PART NUMBER:

The "*" in the part numbers on page 1 shall be replaced by a color code designator.

1/ Example: AWG 22, white: 55A0211-22-9

AWG 22, white with black stripe: 55A0211-22-90

1/ See footer section on page 1

Mouser Electronics

Authorized Distributor

Click to View Pricing, Inventory, Delivery & Lifecycle Information:

[TE Connectivity:](#)

[55A0211-6-9](#)



Компания «ЭлектроПласт» предлагает заключение долгосрочных отношений при поставках импортных электронных компонентов на взаимовыгодных условиях!

Наши преимущества:

- Оперативные поставки широкого спектра электронных компонентов отечественного и импортного производства напрямую от производителей и с крупнейших мировых складов;
- Поставка более 17-ти миллионов наименований электронных компонентов;
- Поставка сложных, дефицитных, либо снятых с производства позиций;
- Оперативные сроки поставки под заказ (от 5 рабочих дней);
- Экспресс доставка в любую точку России;
- Техническая поддержка проекта, помощь в подборе аналогов, поставка прототипов;
- Система менеджмента качества сертифицирована по Международному стандарту ISO 9001;
- Лицензия ФСБ на осуществление работ с использованием сведений, составляющих государственную тайну;
- Поставка специализированных компонентов (Xilinx, Altera, Analog Devices, Intersil, Interpoint, Microsemi, Aeroflex, Peregrine, Syfer, Eurofarad, Texas Instrument, Miteq, Cobham, E2V, MA-COM, Hittite, Mini-Circuits, General Dynamics и др.);

Помимо этого, одним из направлений компании «ЭлектроПласт» является направление «Источники питания». Мы предлагаем Вам помощь Конструкторского отдела:

- Подбор оптимального решения, техническое обоснование при выборе компонента;
- Подбор аналогов;
- Консультации по применению компонента;
- Поставка образцов и прототипов;
- Техническая поддержка проекта;
- Защита от снятия компонента с производства.



Как с нами связаться

Телефон: 8 (812) 309 58 32 (многоканальный)

Факс: 8 (812) 320-02-42

Электронная почта: org@eplast1.ru

Адрес: 198099, г. Санкт-Петербург, ул. Калинина, дом 2, корпус 4, литера А.