



KYOCERA Display Corporation

Document Title	TVL-55729D090J-LW-I-AAN Product Specification			Page No.	1/24
Document No.	Revision03	Issue date	2013/02/21	Revision	03

Product Specification

To:

Product Name: TVL-55729D090J-LW-I-AAN

Document Issue Date: 2013/02/21

KYD Confidential Document

- Note:
1. Please contact OPTREX before designing your product based on this product.
 2. The information contained herein is presented merely to indicate the characteristics and performance of our products.



KYOCERA Display Corporation

Document Title	TVL-55729D090J-LW-I-AAN Product Specification			Page No.	2/24
Document No.	Revision03	Issue date	2013/02/21	Revision	03

Revision	Date	Page	Old Description	New Description	Remark
00	2011/09/02	All	--	First issued	
01	2012/01/05	11		Update the coordinate of Color Chromaticity	
		22		Update the dimensions in the package part	
02	2012/01/09	17		Update the maximum of T12	
03	2012/1/13	10		Update the definition of CR	
		18、 19		Update the outline drawing	
		21		Update the module weight	
		22		Add the weight the weight of carton with module	

KYD Confidential Document



KYOCERA Display Corporation

Document Title	TVL-55729D090J-LW-I-AAN Product Specification			Page No.	3/24
Document No.	Revision03	Issue date	2013/02/21	Revision	03

Contents

1.0 General Descriptions Introduction	4
2.0 Absolute Maximum Ratings	6
3.0 Pixel Format Image	7
4.0 Optical Characteristics	8
6.0 Electrical Characteristics	14
7.0 Interface Timings	16
8.0 Power Consumption	16
9.0. Power ON/OFF Sequence	17
10.0 Mechanical Characteristics	18
11.0 Reliability	21
12.0 Package Specification	22
14.0 General Precaution	23

Document Title	TVL-55729D090J-LW-I-AAN Product Specification			Page No.	4/24
Document No.	Revision03	Issue date	2013/02/21	Revision	03

1.0 General Descriptions Introduction

The TVL-55729D090J-LW-I-AAN is a color active matrix thin film transistor (TFT) liquid crystal display (LCD) that uses amorphous silicon TFT as a switching device. It is composed of a TFT LCD panel, a timing controller, voltage reference, common voltage, column driver, and row driver circuit. This TFT LCD has a 9.0-inch diagonally measured active display area with resolution (800 horizontal by 480 vertical pixel array).

1.1 Features

- 9.0" TFT LCD Panel
- LED Backlight System
- Supported (800x480 pixels) Resolution
- Compatible With RoHS Standard

1.2 Product Summary

Items	Specifications	Unit
Screen Diagonal	9.0	Inch
Active Area	198.000 (H) x111.696 (V)	mm
Pixels H x V	800(RGB) x480	-
Pixel Pitch	0.0825(H)x0.2327(V)	mm
Pixel Arrangement	R.G.B. Vertical Stripe	-
Display Mode	Normally White	-
White Luminance	300	cd /m ²
Contrast Ratio	500:1	-
Response Time	25	msec
Input Voltage	3.3	V
Weight	255	g
Outline Dimension	211.1(H) x128.4(V) x6.6(D)	mm
Electrical Interface (Logic)	TTL	-
Support Color	16.7M (6bit+HFRC)	-
Optimum Viewing Direction	6 O' clock	-
Surface Treatment	Anti-Glare (3H)	-

Document Title	TVL-55729D090J-LW-I-AAN Product Specification			Page No.	5/24
Document No.	Revision03	Issue date	2013/02/21	Revision	03

1.3 Functional Block Diagram

Shows the functional block diagram of the LCD module.

Figure 1 Block Diagram

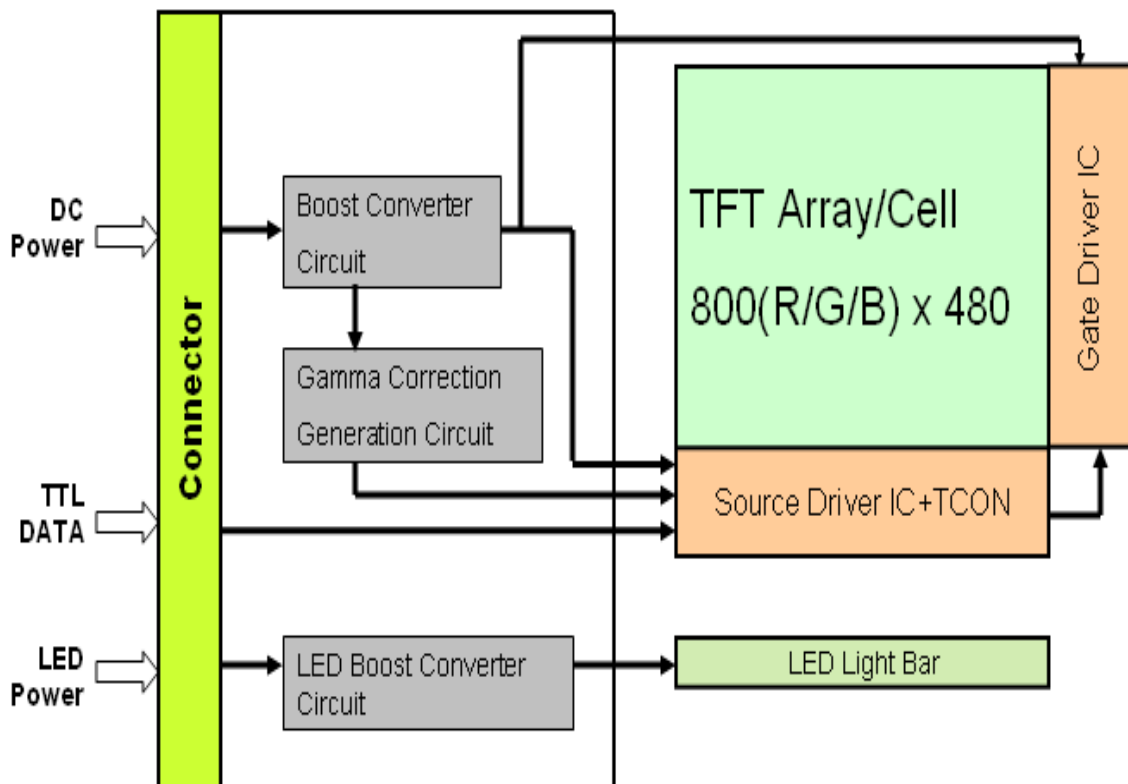

KYD

Document Title	TVL-55729D090J-LW-I-AAN Product Specification			Page No.	6/24
Document No.	Revision03	Issue date	2013/02/21	Revision	03

2.0 Absolute Maximum Ratings

Table 1 Absolute Ratings of Environment

Item	Symbol	Min.	Max.	Unit	Conditions
Supply Voltage	V _{DD}	-0.3	4.0	V	-
Operating Temperature	TOP	-20	75	°C	Note
Operating Humidity	HOP	10	90	%RH	Note
Storage Temperature	TST	-30	80	°C	Note
Storage Humidity	HST	10	90	%RH	Note

Note: When you apply the LCD module for OA system. Please make sure to keep the temperature of LCD module is less than 75°C.

Document Title	TVL-55729D090J-LW-I-AAN Product Specification			Page No.	7/24
Document No.	Revision03	Issue date	2013/02/21	Revision	03

3.0 Pixel Format Image

Figure 2 shows the relationship of the input signals and LCD pixel format image.

Figure 2 Pixel Format

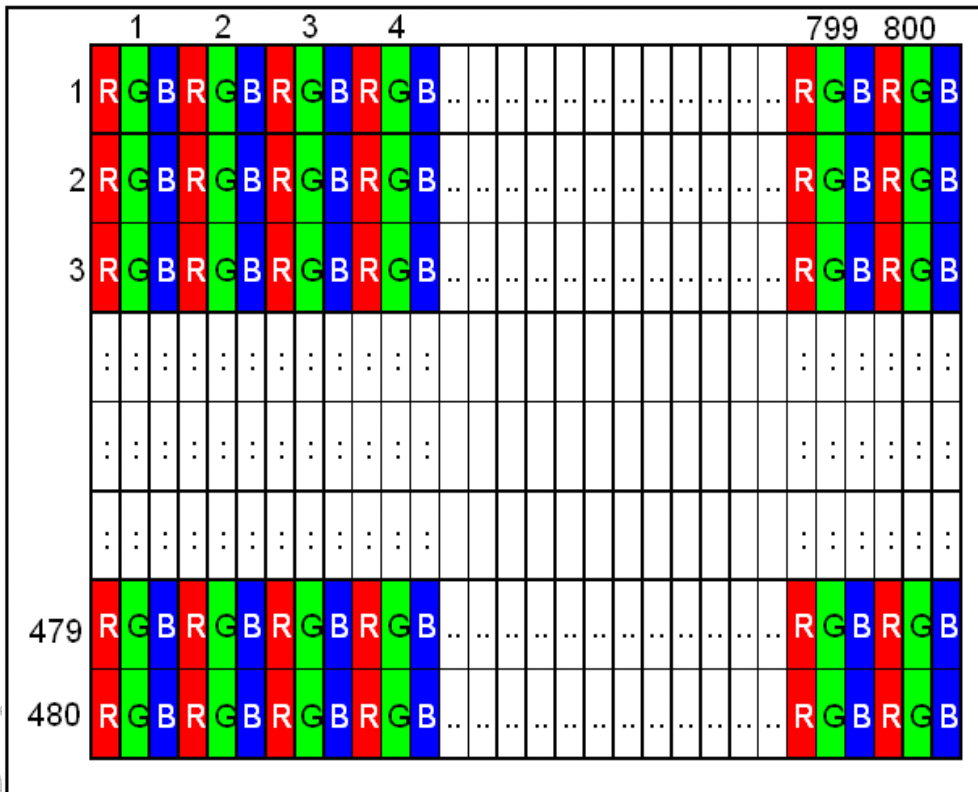

Document Title	TVL-55729D090J-LW-I-AAN Product Specification			Page No.	8/24
Document No.	Revision03	Issue date	2013/02/21	Revision	03

4.0 Optical Characteristics

The optical characteristics are measured under stable conditions as following notes

Table 2 Optical Characteristics

Item	Condition		Specification			
			Min.	Typ.	Max.	Note
Viewing Angle [degrees] K=Contrast Ratio>10	Horizontal	θ_L	60	70	-	A, B, C
		θ_R	60	70	-	
	Vertical	θ_T	40	50	-	
		θ_B	60	70	-	
Contrast Ratio	Center		400	500	-	A, B, D
Response Time [ms]	Rising		-	10	14	A, B, E
	Falling		-	15	21	
	Rising +Falling		-	25	35	
Color Chromaticity (CIE 1,931)	Red	x	0.554	0.584	0.614	A, B
	Red	y	0.328	0.358	0.388	A, B
	Green	x	0.302	0.332	0.362	A, B
	Green	y	0.535	0.565	0.595	A, B
	Blue	x	0.125	0.155	0.185	A, B
	Blue	y	0.063	0.093	0.123	A, B
	White	x	0.263	0.313	0.363	A, B
	White	y	0.279	0.329	0.379	A, B
White Luminance [cd/m ²]	Center		250	300	-	A, B, F
Luminance Uniformity [%]	9Points		70	-	-	A, B, F

Note: A. Measurement Setup:

The LCD module should be stabilized at given temperature for 15 minutes to avoid abrupt temperature change during measuring. In order to stabilize the luminance, the

Document Title	TVL-55729D090J-LW-I-AAN Product Specification			Page No.	9/24
Document No.	Revision03	Issue date	2013/02/21	Revision	03

measurement should be executed after lighting backlight for 15 minutes in a windless room.

Figure 3 Measurement Setup

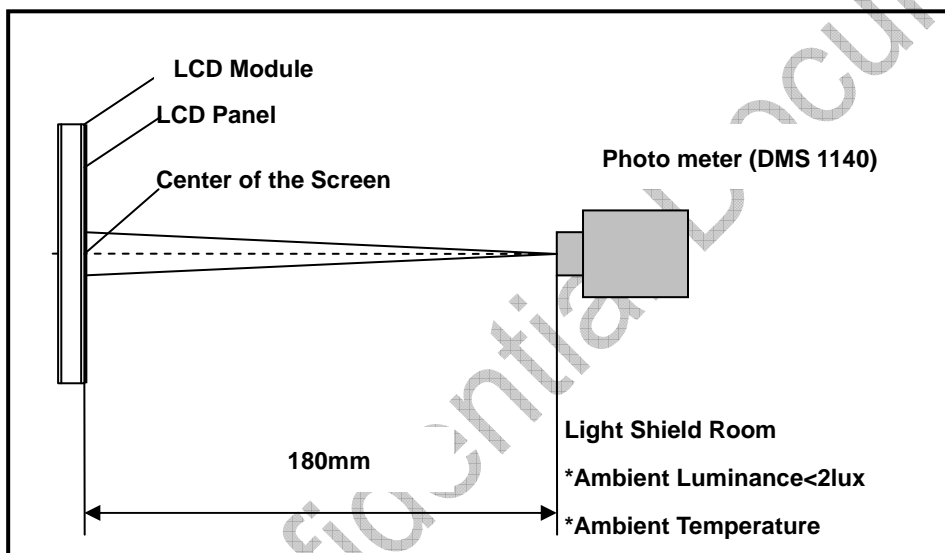

B. The LED input parameter setting as:

V_LED: 12V ($\pm 0.1V$) ; I_LED: 60mA

PWM_LED: Duty 100 %

Document Title	TVL-55729D090J-LW-I-AAN Product Specification			Page No.	10/24
Document No.	Revision03	Issue date	2013/02/21	Revision	03

C. Definition of Viewing Angle

Figure 4 Definition of Viewing Angle

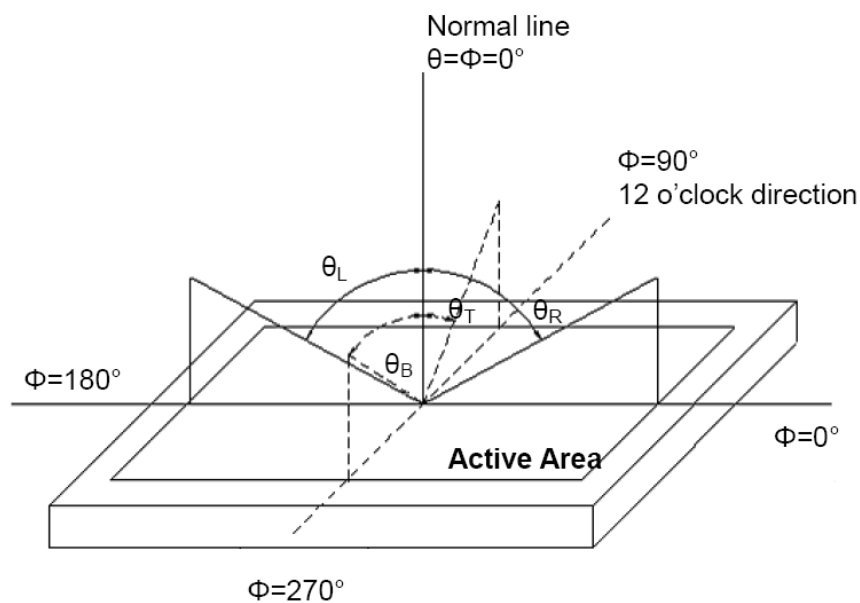

D. Definition Of Contrast Ratio (CR)

The contrast ratio can be calculated by the following expression

$$\text{Contrast Ratio (CR)} = L_{255} / L_0$$

L255: Luminance of gray level 255, L0: Luminance of gray level 0

E. Definition Of Response Time (T_R , T_F)

Figure 5 Definition of Response Time

Document Title	TVL-55729D090J-LW-I-AAN Product Specification			Page No.	11/24
Document No.	Revision03	Issue date	2013/02/21	Revision	03

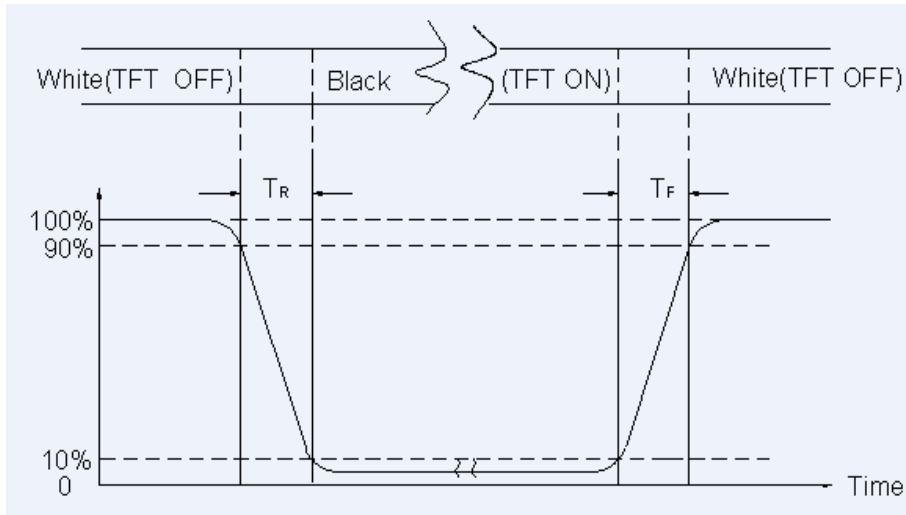

F. Definition Of Brightness Luminance

$$\text{Luminance Uniformity} = \frac{(\text{Min Luminance of 9 points})}{(\text{Max Luminance of 9 points})} \times 100\%$$

Figure 6 Measurement Locations

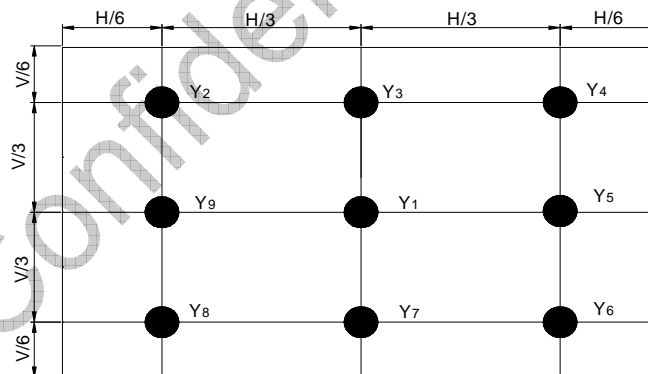

Document Title	TVL-55729D090J-LW-I-AAN Product Specification			Page No.	12/24
Document No.	Revision03	Issue date	2013/02/21	Revision	03

5.0 Backlight Characteristics

5.1 Parameter Guideline Of LED Backlight

Table 3 Parameter Guideline for LED Backlight

Symbol	Parameter	Min.	Typ.	Max.	Units	Condition	
VLED	LED Input	5	12	21	[V]	Ta=25℃ Note B	
PLED	LED Power Consumption	-	-	2.1	W	Ta=25℃ Note B	
VLED_PWM	PWM Signal Voltage	High	2.5	-	5.5	V	Ta=25℃
		Low	-	-	0.5	V	
F _{PWM}	PWM diming Frequency	200	-	1K	Hz	Ddim ≥ 5%	
VLED_EN	LED Enable Voltage	High	2.5	-	5.5	V	-
		Low	-	-	0.5	V	
LT	LED Life Time	20,000	-	-	Hours	Ta=25℃ Note A	

Note A: The LED life time define as the estimated time to 50% degradation of initial luminous.

Document Title	TVL-55729D090J-LW-I-AAN Product Specification			Page No.	13/24
Document No.	Revision03	Issue date	2013/02/21	Revision	03

Note B: A higher LED power supply voltage will result in better power efficiency. Keep the VLED between 12V and 21V is strongly recommended.

Figure 7 LED Rush Current Measure Condition

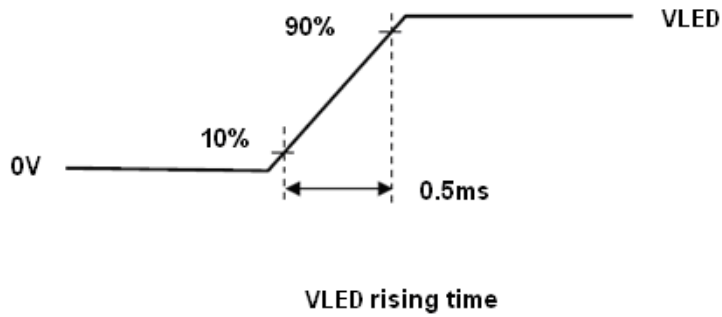

Document Title	TVL-55729D090J-LW-I-AAN Product Specification			Page No.	14/24
Document No.	Revision03	Issue date	2013/02/21	Revision	03

6.0 Electrical Characteristics

6.1 TFT LCD Module Interface Connector

Table 4 Connector Name / Designation

Item	Description
Type / Part Number	089H50-000000-G2-R

Table 5 Signal Pin Assignment

Pin #	Signal Name	Description	Remarks
1	GND	Ground	-
2	GND	Ground	-
3	VDD	Power Supply	3.3V(typical)
4	VDD	Power Supply	3.3V(typical)
5	UPDN	Gate up or down scan control	-
6	SHLR	Source right or left sequence control	-
7	GND	Ground	-
8	R0	Data Input (LSB)	-
9	R1	Data Input	-
10	R2	Data Input	-
11	R3	Data Input	-
12	GND	Ground	-
13	R4	Data Input	-
14	R5	Data Input	-
15	GND	Ground	-
16	R6	Data Input	-
17	R7	Data Input (MSB)	-
18	GND	Ground	--
19	G0	Data Input (LSB)	-
20	G1	Data Input	-
21	G2	Data Input	-
22	G3	Data Input	-
23	GND	Ground	-
24	G4	Data Input	-
25	G5	Data Input	-

Document Title	TVL-55729D090J-LW-I-AAN Product Specification			Page No.	15/24
Document No.	Revision03	Issue date	2013/02/21	Revision	03

26	GND	Ground	-
27	G6	Data Input	-
28	G7	Data Input (MSB)	-
29	GND	Ground	-
30	B0	Data Input (LSB)	-
31	B1	Data Input	-
32	B2	Data Input	-
33	B3	Data Input	-
34	GND	Ground	-
35	B4	Data Input	-
36	B5	Data Input	-
37	GND	Ground	-
38	B6	Data Input	-
39	B7	Data Input (MSB)	-
40	GND	Ground	-
41	DCLK	Clock Input	-
42	GND	Ground	-
43	DE	Data Input Enable	-
44	BIST	Aging Mode	High Enable
45	GND	Ground	-
46	GND	Ground	-
47	LED_PWM	System PWM Signal Input	-
48	LED_EN	LED Enable Pin	-
49	VLED	LED Power Supply	-
50	VLED	LED Power Supply	-

Note1: When input 18 bits RGB data, the two low bits of R,G and B data must be grounded.

Note2: Data shall be latched at falling edge of DCLK.

Note3: Selection of scanning mode

Setting of scan control input		Scanning Direction
SHLR	UPDN	
VDD	GND	Left to Right, Up to Down
GND	GND	Right to Left, Up to Down
VDD	VDD	Left to Right, Down to Up
GND	VDD	Right to Left, Down to Up

Document Title	TVL-55729D090J-LW-I-AAN Product Specification			Page No.	16/24
Document No.	Revision03	Issue date	2013/02/21	Revision	03

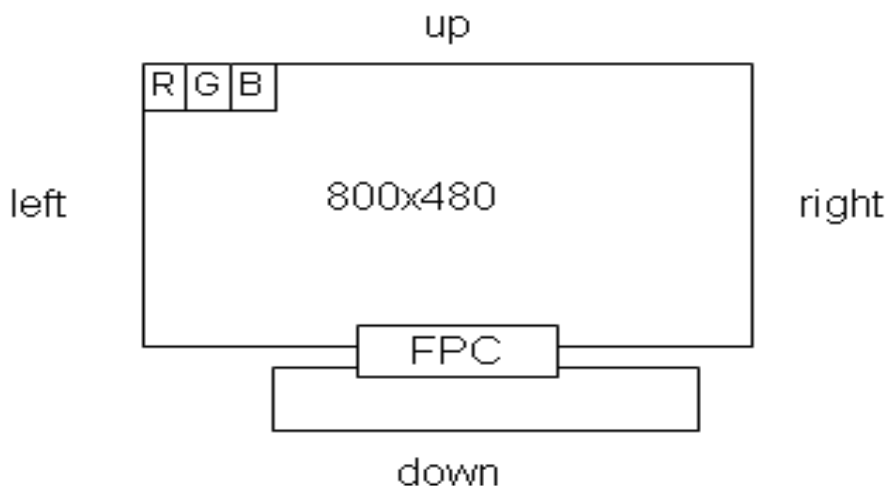

7.0 Interface Timings

7.1 Timing Characteristics

Table 6 Interface Timings

Synchronization Method : DE only

Parameter	Symbol	Min	Typ	Max	Unit	Note
DCLK Frequency	fclk	28	30	40	MHz	-
Horizontal Display Area	thd	800			DCLK	-
One Horizontal Line	th	908	928	1080	DCLK	-
H Blank Area	th-blank	108	128	280	DCLK	-
Vertical Display Area	tvd	480			H	-
V Period time	tv	517	525	704	H	-
V Blank Area	tv-blank	37	45	224	H	-

Note: H Blank area and V Blank area can not be changed at every frame

Table 7 DC Electrical

(VDD=2.7 to 3.6V ,TA=-20 to +85°C)

Parameter	Symbol	Min.	Typ.	Max.	Unit	Conditions
Low level input voltage	Vil	0	-	0.3*VDD	V	For the digital circuit

Document Title	TVL-55729D090J-LW-I-AAN Product Specification			Page No.	17/24
Document No.	Revision03	Issue date	2013/02/21	Revision	03

High level input voltage	Vih	0.7*VDD	-	VDD	V	For the digital circuit
--------------------------	-----	---------	---	-----	---	-------------------------

7.2 Timing Diagram of Interface Signal

Figure 8 Timing Characteristics

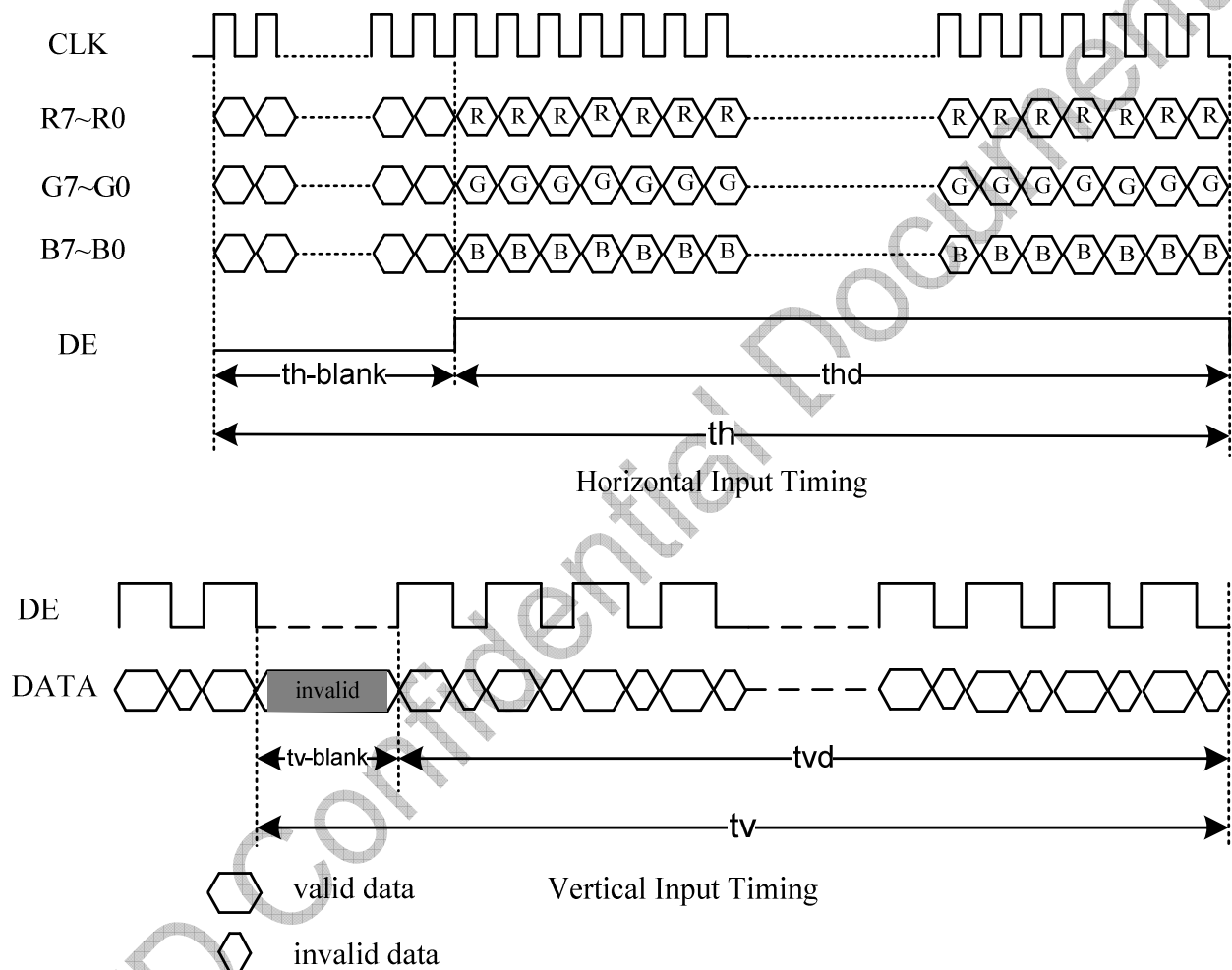

Document Title	TVL-55729D090J-LW-I-AAN Product Specification			Page No.	16/24
Document No.	Revision03	Issue date	2013/02/21	Revision	03

8.0 Power Consumption

Input power specifications are as follows.

Table 8 Power Consumption

Symbol	Parameter	Min.	Typ.	Max.	Units	Condition
VDD	Logic/LCD Drive Voltage	3.0	3.3	3.6	[V]	-
IDD	VDD Current	-	0.1	-	[A]	-
PDD	VDD Power	-	-	0.7	[W]	Black Pattern, 60Hz
Irush	Rush Current	-	-	1.5	[A]	Note1
VDDrp	Allowable Logic/LCD Drive Ripple Voltage	-	-	200	[mV]p-p	Note 2

Note 1. Measure Condition

Figure 9 VDD rising time

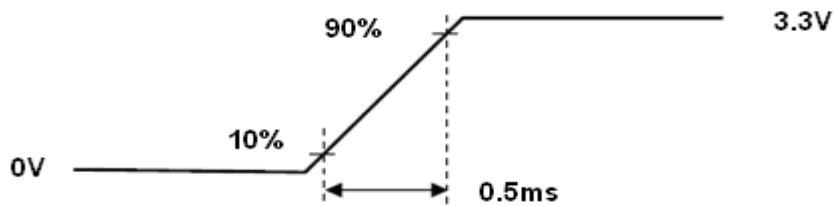

VDD rising time

Note 2. VDD Power Dip Condition

Figure 10 VDD Power Dip

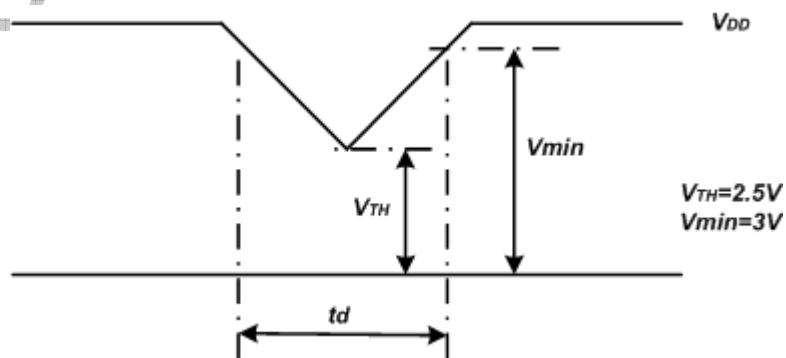

If $V_{TH} < V_{DD} \leq V_{min}$, then $t_d \leq 10ms$; When the voltage return to normal our panel

Document Title	TVL-55729D090J-LW-I-AAN Product Specification			Page No.	17/24
Document No.	Revision03	Issue date	2013/02/21	Revision	03

must revive automatically.

9.0. Power ON/OFF Sequence

VDD power on/off sequence is as follows. Interface signals are also shown in the chart. Signals from any system shall be Hi-Z state or low level when VDD is off.

Figure 11 Power Sequence

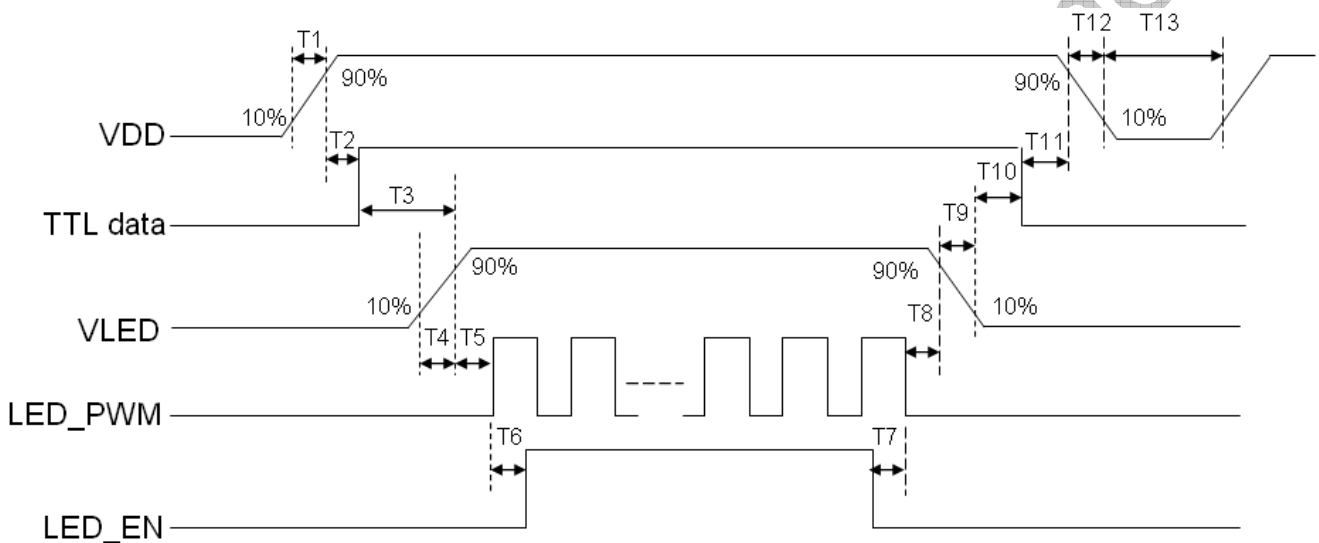

Table 9 Power Sequencing Requirements

Parameter	Symbol	Unit	Min	Typ	Max
VDD Rise Time	T1	ms	0.5	--	10
VDD Good to Signal Valid	T2	ms	30	--	90
Signal Valid to Backlight On	T3	ms	200	--	--
Backlight Power On Time	T4	ms	0.5	--	--
Backlight Power Good to System PWM On	T5	ms	10	--	--
System PWM ON to Backlight Enable On	T6	ms	10	--	--
Backlight Enable Off to System PWM Off	T7	ms	0	--	--
System PWM Off to B/L Power Disable	T8	ms	10	--	--
Backlight Power Off Time	T9	ms	--	10	30
Backlight Off to Signal Disable	T10	ms	200	--	--
Signal Disable to VDD Down	T11	ms	0	--	50

Document Title	TVL-55729D090J-LW-I-AAN Product Specification			Page No.	18/24
Document No.	Revision03	Issue date	2013/02/21	Revision	03

VDD Fall Time	T12	ms	1	--	30
VDD Off Time	T13	ms	500	--	--

10.0 Mechanical Characteristics

10.1 Outline Drawing

Figure 12 Reference Outline Drawing (Front Side)

KYD Confidential Document

Document Title	TVL-55729D090J-LW-I-AAN Product Specification			Page No.	19/24
Document No.	Revision03	Issue date	2013/02/21	Revision	03

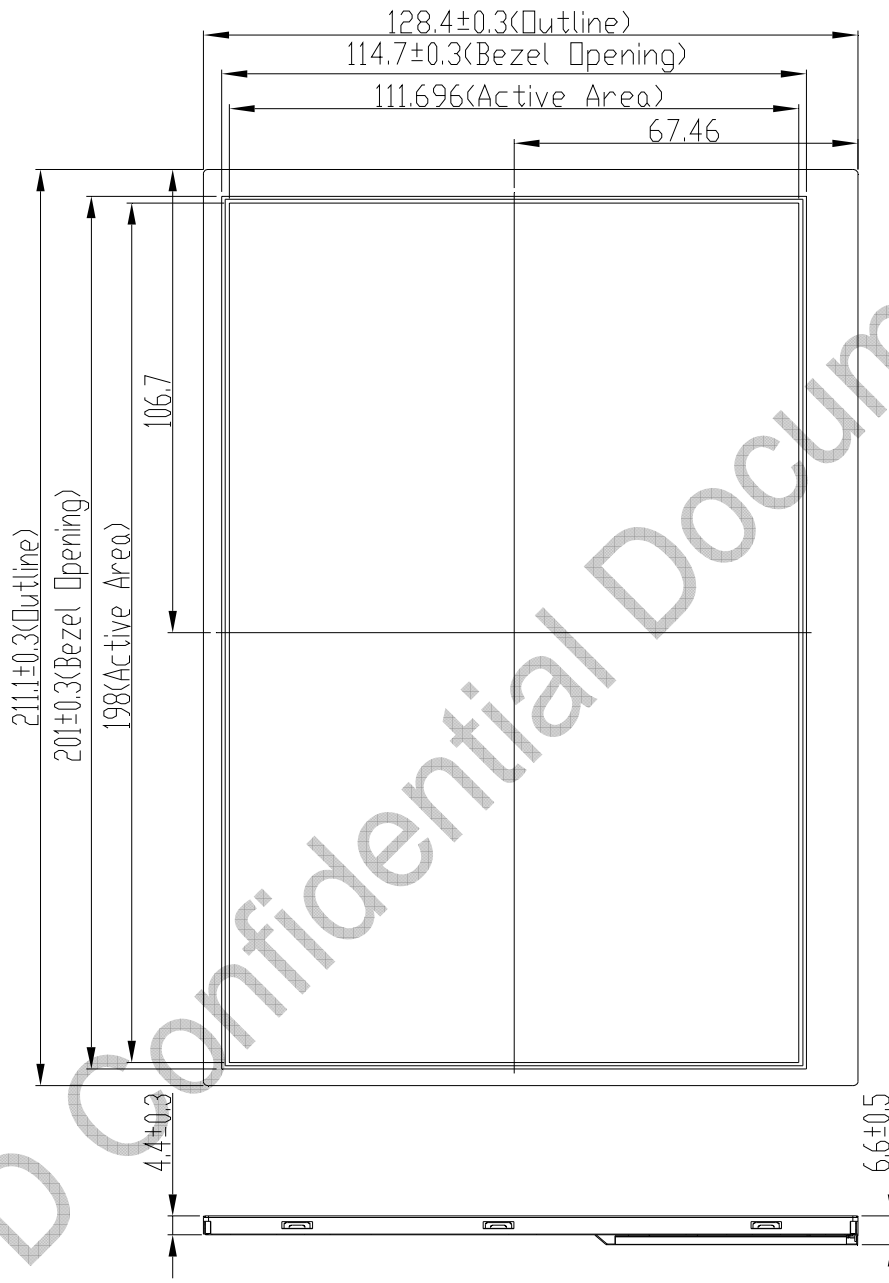
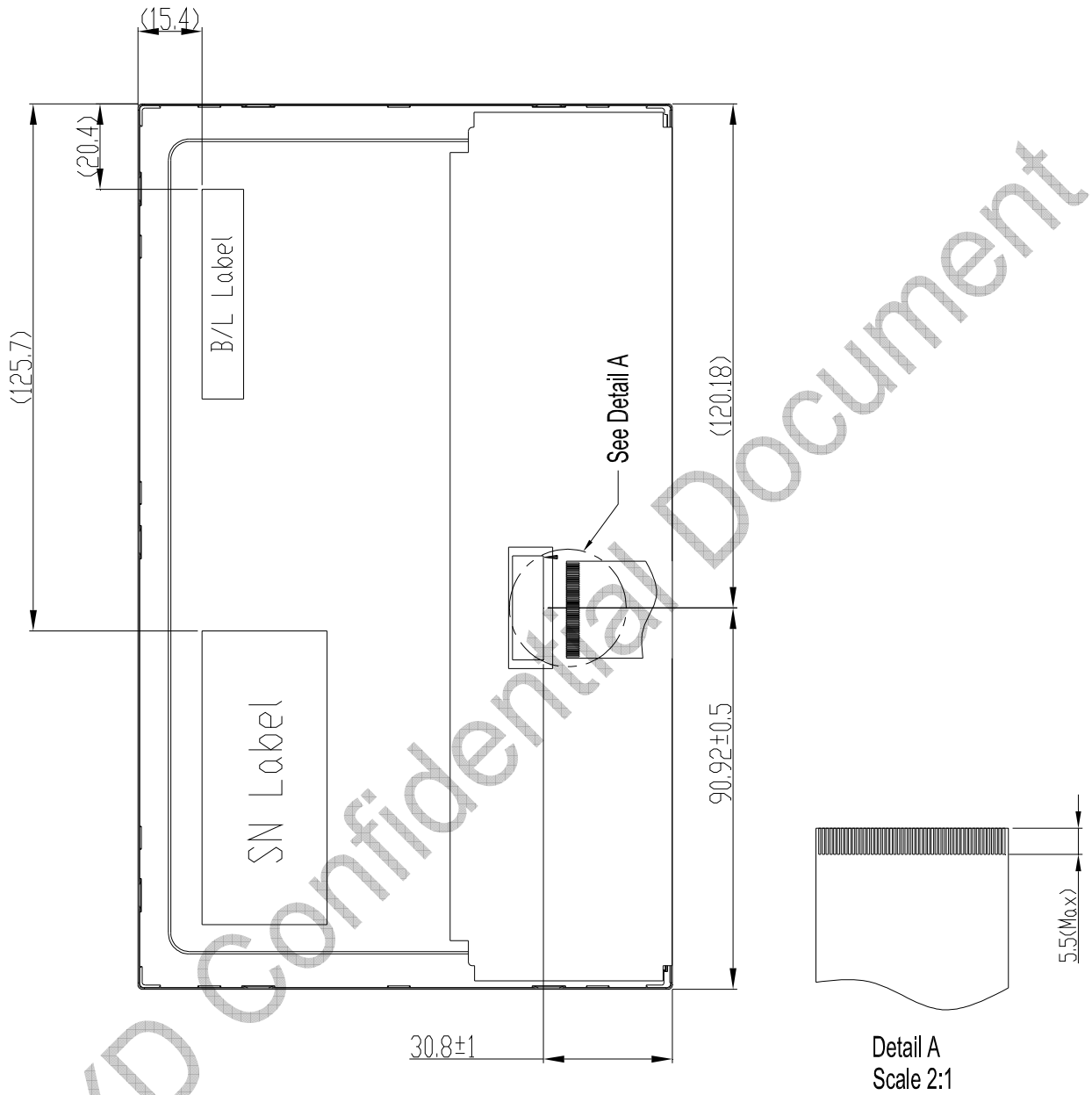

Figure 13 Reference Outline Drawing (Back Side)

Document Title	TVL-55729D090J-LW-I-AAN Product Specification			Page No.	20/24
Document No.	Revision03	Issue date	2013/02/21	Revision	03



Document Title	TVL-55729D090J-LW-I-AAN Product Specification			Page No.	21/24
Document No.	Revision03	Issue date	2013/02/21	Revision	03

10.2 Dimension Specifications

Table 10 Module Dimension Specifications

Width [mm]	211.1±0.3
Height [mm]	128.4±0.3
Thickness [mm]	6.6±0.5
Weight [g]	255±8%

11.0 Reliability

Item	Criterion
A	There is no function defect and occurrence of any new defective shall not be allowed.
B	In case of malfunction defect caused by ESD damage. If it would be recovered to normal state after resetting, it would be judge as pass.
C	Image Sticking is not visible through 8% ND filter after 10 mins with 50%Grayscale pattern.

Item	Package	Test Conditions	Conditions
High Temperature Storage Test	Module	80°C, 300hrs	A
Low Temperature Storage Test	Module	-30°C, 300hrs	A
High Temp./High Humidity Storage Test	Module	50°C, 90%, 300hrs	A
High Temperature Operation Test	Module	75°C, 300hrs	A
Low Temperature Operating Test	Module	-20°C, 300hrs	A
High Temp./High Humidity Operating Test	Module	50°C, 90%, 300hrs	A
Thermal Shock Non-operation Test	Module	-30°C ~ 80°C; 1hr/each cycle, 200cycles	A
Shock Test	With package	Half Sine Wave ±X, Y, Z 240G, 2ms, 1 Times each axis	A
Vibration Test	With package	1.5G, 10~500 Hz, x, y, z each axis/1h	A
ESD Test	Module	<contact> operate ±8kV <Air> operate ±15kV	B
Image Sticking test	Module	25°C, chess pattern (7*5) test 8hrs	C

Document Title	TVL-55729D090J-LW-I-AAN Product Specification			Page No.	22/24
Document No.	Revision03	Issue date	2013/02/21	Revision	03

- Note: 1. In Operating test ,the B/L voltage and current must be in spec.
 2. All the judgments are under normal temperature and the sample need to be static more than 2 hours in the normal temperature before judge.
 3. During measurement, the condensation water or remains shall not be allowed.
 4. The minimum sample quantity of test is 3pcs.
 5. There is no display function fail issue occurred, all the cosmetic specification is judged before the reliability stress.

12.0 Package Specification

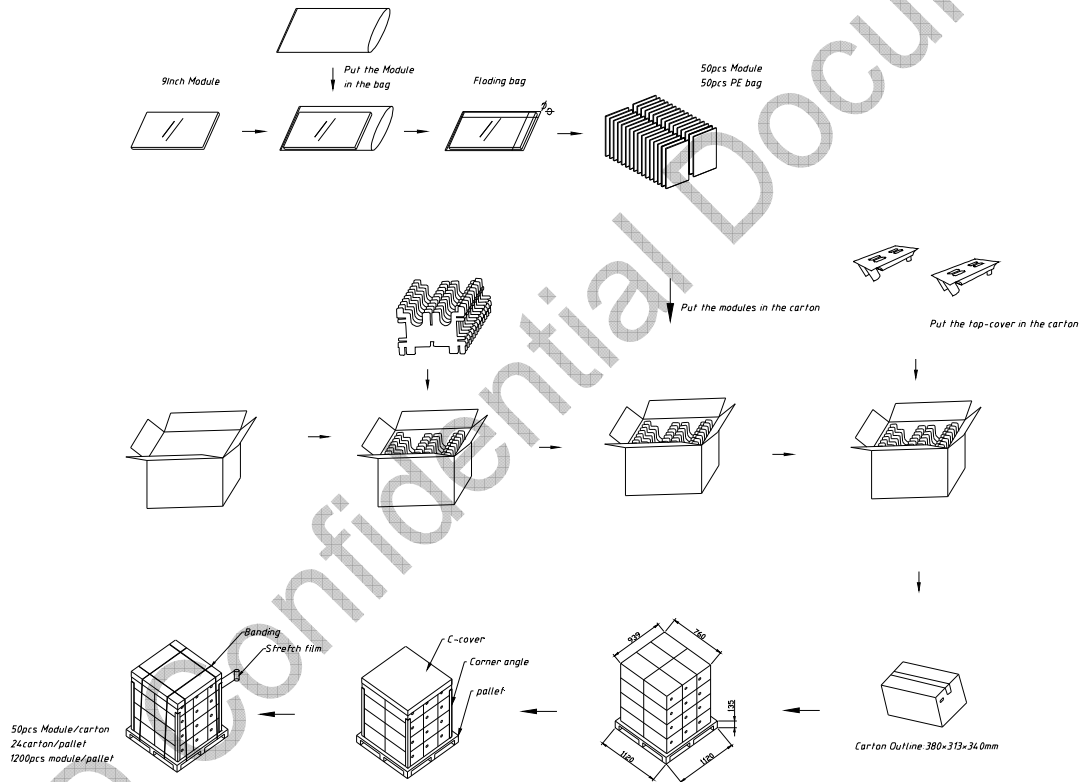

Components Material	Carton	PE Bag	Module	Protect Film	weight
Material Size(mm)	380*313*340 (Outline)	255*137*0.06	211.1*128.4*6.6 (Outline)	205*122*0.08	15.5kg
Amount	1	50	50	50	50Pcs module

Document Title	TVL-55729D090J-LW-I-AAN Product Specification			Page No.	23/24
Document No.	Revision03	Issue date	2013/02/21	Revision	03

(Pcs/Carton)					(include packing 2.75kg)
--------------	--	--	--	--	-----------------------------

13.0 Lot Mark

TBD

14.0 General Precaution

14.1 Use Restriction

This product is not authorized for use in life supporting systems, aircraft navigation control systems, military systems and any other application where performance failure could be life-threatening or otherwise catastrophic.

14.2 Handling Precaution

- (1) Please mount LCD module by using mounting holes arranged in four corners tightly.
- (2) Do not disassemble or modify the module. It may damage sensitive parts inside LCD module, and may cause scratches or dust on the display. OPTREX does not warrant the module, if customers disassemble or modify the module.
- (3) If LCD panel is broken and liquid crystal spills out, do not ingest or inhale liquid Crystal, and do not contact liquid crystal with skin. If liquid crystal contacts mouth or eyes, rinse out with water immediately. If liquid crystal contacts skin or cloths, wash it off immediately with alcohol and Rinse thoroughly with water.
- (4) Disconnect power supply before handling LCD module
- (5) Refrain from strong mechanical shock and /or any force to the module.
- (6) Do not exceed the absolute maximum rating values, such as the supply voltage variation, input voltage variation, variation in parts' parameters, environmental temperature; etc otherwise LCD module may be damaged. It's recommended employing protection circuit for power supply.
- (7) Do not touch, push or rub the polarizer with anything harder than HB pencil lead. Use fingerstalls of soft gloves in order to keep clean display quality, when Persons handle the LCD module for incoming inspection or assembly.
- (8) When the surface is dusty, please wipe gently with absorbent cotton or other soft Material. When cleaning the adhesives, please use absorbent cotton wetted with a little Petroleum benzene or other adequate solvent.
- (9) Wipe off saliva or water drops as soon as possible. If saliva or water drops Contact with polarizer for a long time, they may causes deformation or color Fading.
- (10) Protection film must remove very slowly from the surface of LCD module to Prevent from electrostatic occurrence.
- (11) Because LCD module uses CMOS-IC on circuit board and TFT-LCD panel, it is Very weak to electrostatic discharge, Please be careful with electrostatic Discharge .Persons who handle the module should be grounded through adequate methods.
- (12) Do not adjust the variable resistor located on the module.

14.3 Storage Precaution

- (1) Please do not leave LCD module in the environment of high humidity and high

Document Title	TVL-55729D090J-LW-I-AAN Product Specification			Page No.	24/24
Document No.	Revision03	Issue date	2013/02/21	Revision	03

temperature for a long time.

- (2) The module shall not be exposed under strong light such as direct sunlight. Otherwise, Display characteristics may be changed.
- (3) The module should be stored in a dark place. It is prohibited to apply sunlight or fluorescent light in storage.

14.4 Operation Precaution

- (1) Do not connect or disconnect the module in the "Power On" condition.
- (2) Power supply should always be turned on/off by 9.0 "Power on/off sequence"
- (3) Module has high frequency circuits. Sufficient suppression to the electromagnetic interference should be done by system manufacturers. Grounding and shielding methods may be important to minimize the interference.
- (4) After installation of the TFT Module into an enclosure, do not twist nor bend the TFT Module even momentary. At designing the enclosure, it should be taken into consideration that no bending/twisting forces are applied to the TFT Module from outside. Otherwise the TFT Module may be damaged.

14.5 Others

- (1) Ultra-violet ray filter is necessary for outdoor operation.
- (2) Avoid condensation of water which may result in improper operation or disconnection of electrode.
- (3) If the module keeps displaying the same pattern for a long period of time, the image may be "sticked" to the screen.
- (4) This module has its circuitry PCB's on the rear side and should be handled carefully in order not to be stressed.

14.6 Disposal

When disposing LCD module, obey the local environmental regulations.



Компания «ЭлектроПласт» предлагает заключение долгосрочных отношений при поставках импортных электронных компонентов на взаимовыгодных условиях!

Наши преимущества:

- Оперативные поставки широкого спектра электронных компонентов отечественного и импортного производства напрямую от производителей и с крупнейших мировых складов;
- Поставка более 17-ти миллионов наименований электронных компонентов;
- Поставка сложных, дефицитных, либо снятых с производства позиций;
- Оперативные сроки поставки под заказ (от 5 рабочих дней);
- Экспресс доставка в любую точку России;
- Техническая поддержка проекта, помощь в подборе аналогов, поставка прототипов;
- Система менеджмента качества сертифицирована по Международному стандарту ISO 9001;
- Лицензия ФСБ на осуществление работ с использованием сведений, составляющих государственную тайну;
- Поставка специализированных компонентов (Xilinx, Altera, Analog Devices, Intersil, Interpoint, Microsemi, Aeroflex, Peregrine, Syfer, Eurofarad, Texas Instrument, Miteq, Cobham, E2V, MA-COM, Hittite, Mini-Circuits, General Dynamics и др.);

Помимо этого, одним из направлений компании «ЭлектроПласт» является направление «Источники питания». Мы предлагаем Вам помощь Конструкторского отдела:

- Подбор оптимального решения, техническое обоснование при выборе компонента;
- Подбор аналогов;
- Консультации по применению компонента;
- Поставка образцов и прототипов;
- Техническая поддержка проекта;
- Защита от снятия компонента с производства.



Как с нами связаться

Телефон: 8 (812) 309 58 32 (многоканальный)

Факс: 8 (812) 320-02-42

Электронная почта: org@eplast1.ru

Адрес: 198099, г. Санкт-Петербург, ул. Калинина, дом 2, корпус 4, литера А.