



# Inductors

## RF chokes, LBC series

**Series/Type:** B82144F

**Date:** June 2012

© EPCOS AG 2015. Reproduction, publication and dissemination of this publication, enclosures hereto and the information contained therein without EPCOS' prior express consent is prohibited.

EPCOS AG is a TDK Group Company.

**LBC chokes, axial leaded**  
**Rated inductance 1 ... 100000  $\mu$ H**  
**Rated current 20 ... 2500 mA**

### Construction

- Large ferrite drum core
- Winding: enamel copper wire
- Flame-retardant lacquer coating

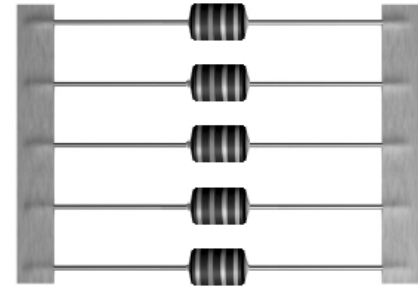

### Features

- Very wide inductance range
- High rated current
- Suitable for wave soldering
- RoHS-compatible

### Applications

- RF blocking and filtering
- Decoupling and interference suppression
- For telecommunications, automotive electronics, energy-saving lamps, entertainment electronics

### Terminals

- Central axial lead
- Base material CuAg0.1
- Electroplated with nickel and pure tin

### Marking

- Inductance indicated by color bands in accordance with IEC 60062

### Delivery mode and packing unit

- Taped, reel packing
- Packing unit:

	Ammo (pcs./pack)	Reel (pcs./reel)
B82144F	1200	1500

**Dimensional drawing**

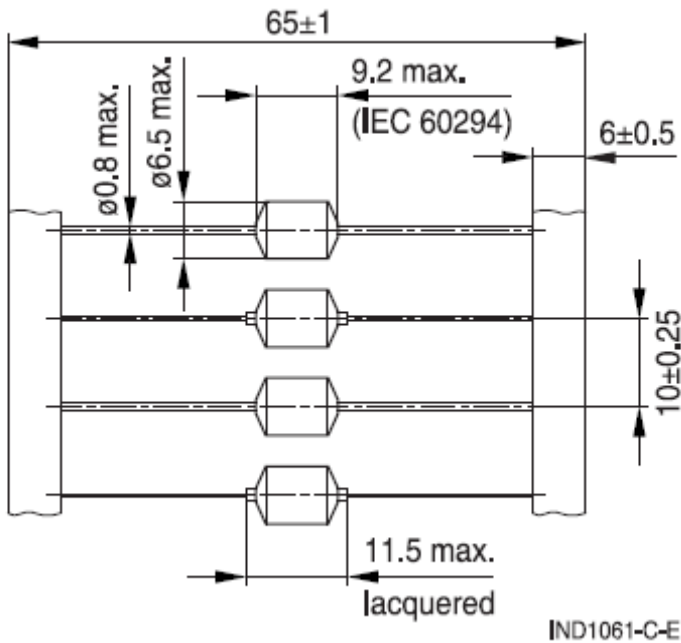

Dimensions in mm

**Packing**

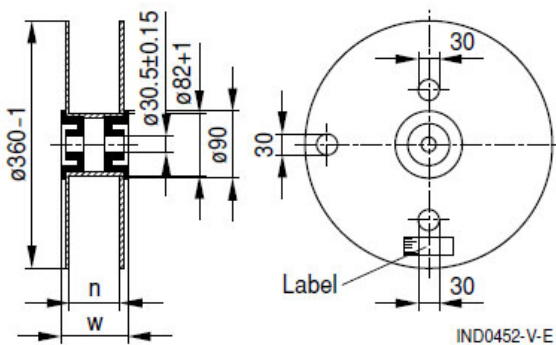

n (mm): 72 + 1  
w (mm): 84 max.

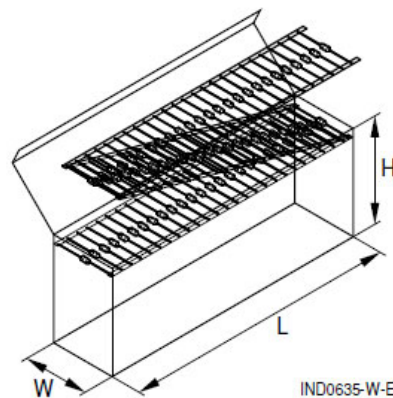

L × B × H (max. mm): 275 × 75 × 140

Dimensions in mm

**Technical data and measuring conditions**

Rated inductance $L_R$	Measured with LCR meter Agilent 4284A or impedance analyzer Agilent 4294A Measuring frequency: $L_R \leq 10 \mu\text{H}$ = 1 MHz $10 \mu\text{H} < L_R \leq 4700\mu\text{H}$ = 100 kHz $L_R > 4700\mu\text{H}$ = 10 kHz Measuring current: $\leq 1 \text{ mA}$ Measuring temperature: $+20 \text{ }^\circ\text{C}$
Q factor $Q_{\min}$	Measured with precision impedance analyzer Agilent 4294A, $+20 \text{ }^\circ\text{C}$
Rated temperature $T_R$	$+40 \text{ }^\circ\text{C}$
Rated current $I_R$	Maximum permissible DC current at rated temperature
Inductance decrease $\Delta L/L_0$	$\leq 10\%$ (referred to initial value) at $I_R$ , $+20 \text{ }^\circ\text{C}$
DC resistance $R_{\max}$	Measured at $+20 \text{ }^\circ\text{C}$
Resonance frequency $f_{\text{res},\min}$	Measured with Agilent 4294A or 8753ES, $+20 \text{ }^\circ\text{C}$
Solderability (lead-free)	Sn95.5Ag3.8Cu0.7: $+(245 \pm 5) \text{ }^\circ\text{C}$ , $(+3 \pm 0.3) \text{ s}$ Wetting of soldering area $\geq 90\%$ (to IEC 60068-2-20, test Ta)
Resistance to soldering heat	$(+260 \pm 5)^\circ\text{C}$ , $+10 \text{ s}$ (to IEC 60068-2-20, test Tb)
Tensile strength of leads	$\geq 20 \text{ N}$ (to IEC 60068-2-21, test Ua)
Climatic category	55/125/56 (to IEC 60068-1)
Storage conditions	Mounted: $-55 \text{ }^\circ\text{C} \dots +125 \text{ }^\circ\text{C}$ Packaged: $-25 \text{ }^\circ\text{C} \dots +40 \text{ }^\circ\text{C}$ , $\leq 75\% \text{ RH}$
Weight	Approx. 0.95 g

**Mounting information**

When bending the leads, take care that the start-of-winding areas at the face ends (protected by glue and lacquer) are not subjected to any mechanical stress.

**Characteristics and ordering codes**

L <sub>R</sub> [μH]	Tolerance <sup>1)</sup>	Q <sub>min</sub>	f <sub>Q</sub> [MHz]	I <sub>R</sub> [mA]	R <sub>max</sub> [Ω]	f <sub>res,min</sub> [MHz]	Ordering code <sup>2)</sup>	
1.0 1.5 2.2	±10% Δ K	25	7.96	2500	0.06	200	B82144F1102K000	
		25	7.96	2300	0.07	180	B82144F1152K000	
		25	7.96	2100	0.09	140	B82144F1222K000	
3.3 4.7 6.8			25	7.96	1950	0.10	120	B82144F1332K000
			25	7.96	1800	0.12	100	B82144F1472K000
			25	7.96	1600	0.15	60	B82144F1682K000
10 15 22			60	2.52	1500	0.18	24	B82144F1103K000
			60	2.52	1400	0.22	17	B82144F1153K000
			50	2.52	1250	0.28	12	B82144F1223K000
33 47 56		± 5% Δ J	40	2.52	1100	0.35	8.0	B82144F1333J000
			40	2.52	900	0.41	7.0	B82144F1473J000
			40	2.52	850	0.47	7.0	B82144F1563J000
68 100 150			30	2.52	800	0.52	6.2	B82144F1683J000
			40	0.796	760	0.70	5.2	B82144F1104J000
			40	0.796	670	0.90	4.5	B82144F1154J000
220 330 470			40	0.796	550	1.30	3.8	B82144F1224J000
			30	0.796	500	1.70	3.2	B82144F1334J000
			30	0.796	400	2.20	2.9	B82144F1474J000
680 820			20	0.796	340	3.10	2.6	B82144F1684J000
			20	0.796	310	3.70	2.4	B82144F1824J000
1000 1500 2200			60	0.252	280	4.20	2.2	B82144F1105J000
			60	0.252	230	6.40	1.9	B82144F1155J000
			60	0.252	180	9.50	1.5	B82144F1225J000
3300 4700 5600			60	0.252	150	13.8	1.3	B82144F1335J000
			60	0.252	120	21.0	1.1	B82144F1475J000
			60	0.252	110	28.0	1.0	B82144F1565J000
6800 10000 15000			60	0.252	100	30.0	0.9	B82144F1685J000
			50	0.0796	85	42.0	0.75	B82144F1106J000
			50	0.0796	50	75.0	0.50	B82144F1156J000
22000 33000 47000			50	0.0796	40	120	0.40	B82144F1226J000
			50	0.0796	35	150	0.30	B82144F1336J000
			40	0.0796	30	230	0.26	B82144F1476J000
68000 100000			40	0.0796	25	290	0.20	B82144F1686J000
		40	0.0796	20	490	0.18	B82144F1107J000	

<sup>1)</sup> Closer tolerance on request.

<sup>2)</sup> For Ammo pack the last digit has to be a "9". Example: B82144F1223K009

**Impedance  $|Z|$  versus frequency  $f$**   
 measured with impedance analyzer Agilent 4294A or S-parameter network analyzer Agilent 8753ES, typical values at +20°C

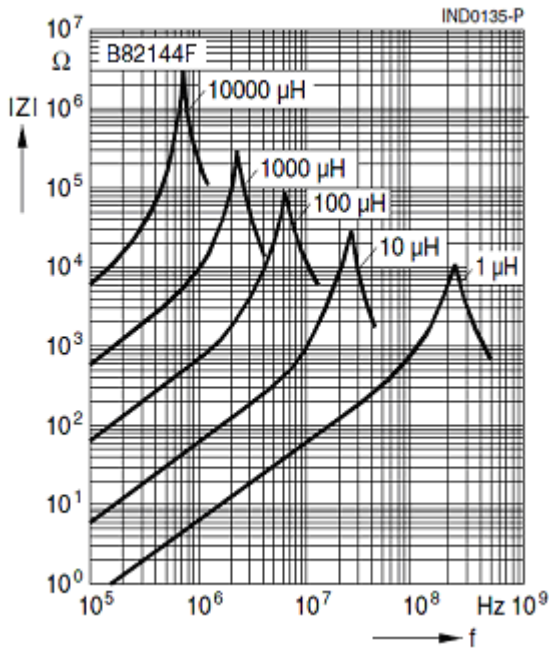

**Inductance  $L$  versus DC load current  $I_{DC}$**   
 measured with LCR meter Agilent 4284A, typical values at +20°C

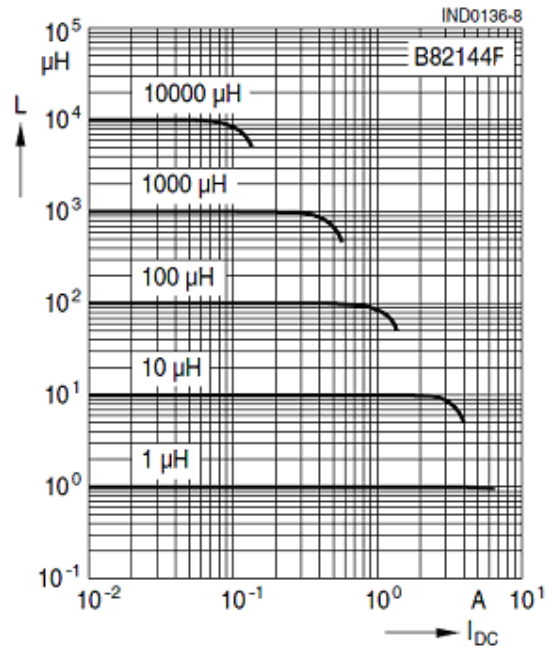

**Q factor versus frequency  $f$**   
 measured with impedance analyzer Agilent 4294A, typical values at +20°C

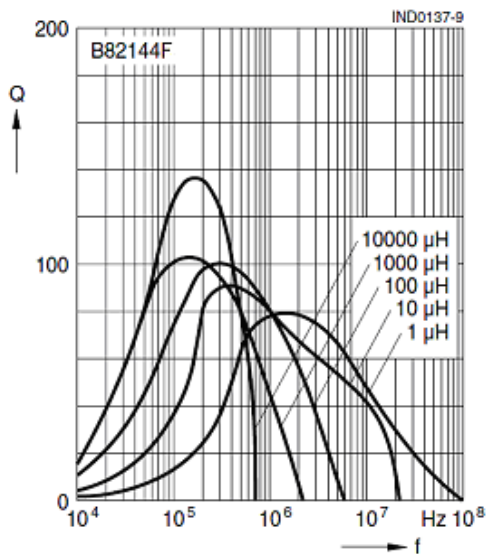

**Current derating  $I_{OP}/I_R$  versus ambient temperature  $T_A$**   
 (rated temperature  $T_R = +40°C$ )

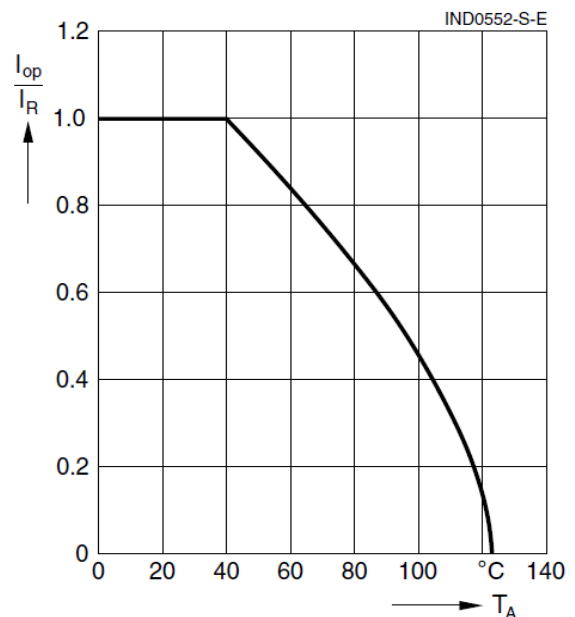

## Cautions and warnings

### Cautions and warnings

- Please note the recommendations in our Inductors data book (latest edition) and in the data sheets.
  - Particular attention should be paid to the derating curves given there.
  - The soldering conditions should also be observed. Temperatures quoted in relation to wave soldering refer to the pin, not the housing.
  
- If the components are to be washed varnished it is necessary to check whether the washing varnish agent that is used has a negative effect on the wire insulation, any plastics that are used, or on glued joints. In particular, it is possible for washing varnish agent residues to have a negative effect in the long-term on wire insulation  
Washing processes may damage the product due to the possible static or cyclic mechanical loads (e.g. ultrasonic cleaning). They may cause cracks to develop on the product and its parts, which might lead to reduced reliability or lifetime.
  
- The following points must be observed if the components are potted in customer applications:
  - Many potting materials shrink as they harden. They therefore exert a pressure on the plastic housing or core. This pressure can have a deleterious effect on electrical properties, and in extreme cases can damage the core or plastic housing mechanically.
  - It is necessary to check whether the potting material used attacks or destroys the wire insulation, plastics or glue.
  - The effect of the potting material can change the high-frequency behaviour of the components.
  
- Ferrites are sensitive to direct impact. This can cause the core material to flake, or lead to breakage of the core.
  
- Even for customer-specific products, conclusive validation of the component in the circuit can only be carried out by the customer.

## Important notes

The following applies to all products named in this publication:

1. Some parts of this publication contain **statements about the suitability of our products for certain areas of application**. These statements are based on our knowledge of typical requirements that are often placed on our products in the areas of application concerned. We nevertheless expressly point out **that such statements cannot be regarded as binding statements about the suitability of our products for a particular customer application**. As a rule we are either unfamiliar with individual customer applications or less familiar with them than the customers themselves. For these reasons, it is always ultimately incumbent on the customer to check and decide whether a product with the properties described in the product specification is suitable for use in a particular customer application.
2. We also point out that **in individual cases, a malfunction of electronic components or failure before the end of their usual service life cannot be completely ruled out in the current state of the art, even if they are operated as specified**. In customer applications requiring a very high level of operational safety and especially in customer applications in which the malfunction or failure of an electronic component could endanger human life or health (e.g. in accident prevention or life-saving systems), it must therefore be ensured by means of suitable design of the customer application or other action taken by the customer (e.g. installation of protective circuitry or redundancy) that no injury or damage is sustained by third parties in the event of malfunction or failure of an electronic component.
3. **The warnings, cautions and product-specific notes must be observed.**
4. In order to satisfy certain technical requirements, **some of the products described in this publication may contain substances subject to restrictions in certain jurisdictions (e.g. because they are classed as hazardous)**. Useful information on this will be found in our Material Data Sheets on the Internet ([www.tdk-electronics.tdk.com/material](http://www.tdk-electronics.tdk.com/material)). Should you have any more detailed questions, please contact our sales offices.
5. We constantly strive to improve our products. Consequently, **the products described in this publication may change from time to time**. The same is true of the corresponding product specifications. Please check therefore to what extent product descriptions and specifications contained in this publication are still applicable before or when you place an order.  
  
We also **reserve the right to discontinue production and delivery of products**. Consequently, we cannot guarantee that all products named in this publication will always be available. The aforementioned does not apply in the case of individual agreements deviating from the foregoing for customer-specific products.
6. Unless otherwise agreed in individual contracts, **all orders are subject to our General Terms and Conditions of Supply**.
7. **Our manufacturing sites serving the automotive business apply the IATF 16949 standard**. The IATF certifications confirm our compliance with requirements regarding the quality management system in the automotive industry. Referring to customer requirements and customer specific requirements ("CSR") TDK always has and will continue to have the policy of respecting individual agreements. Even if IATF 16949 may appear to support the acceptance of unilateral requirements, we hereby like to emphasize that **only requirements mutually agreed upon can and will be implemented in our Quality Management System**. For clarification purposes we like to point out that obligations from IATF 16949 shall only become legally binding if individually agreed upon.
8. The trade names EPCOS, CeraCharge, CeraDiode, CeraLink, CeraPad, CeraPlas, CSMP, CTVS, DeltaCap, DigiSiMic, ExoCore, FilterCap, FormFit, LeaXield, MiniBlue, MiniCell, MKD, MKK, MotorCap, PCC, PhaseCap, PhaseCube, PhaseMod, PhiCap, PowerHap, PQSine, PQvar, SIFERRIT, SIFI, SIKOREL, SilverCap, SIMDAD, SiMic, SIMID, SineFormer, SIOV, ThermoFuse, WindCap are **trademarks registered or pending** in Europe and in other countries. Further information will be found on the Internet at [www.tdk-electronics.tdk.com/trademarks](http://www.tdk-electronics.tdk.com/trademarks).

Release 2018-10



# Mouser Electronics

Authorized Distributor

Click to View Pricing, Inventory, Delivery & Lifecycle Information:

## EPCOS / TDK:

[B82144F1224J000](#) [B82144F1103K000](#) [B82144F1333J000](#) [B82144F1102K000](#) [B82144F1475J000](#)  
[B82144F1106J000](#) [B82144F1107J000](#) [B82144F1104J000](#) [B82144F1334J000](#) [B82144F1155J000](#)  
[B82144F1473J000](#) [B82144F1154J000](#) [B82144F1105J000](#)



Компания «ЭлектроПласт» предлагает заключение долгосрочных отношений при поставках импортных электронных компонентов на взаимовыгодных условиях!

Наши преимущества:

- Оперативные поставки широкого спектра электронных компонентов отечественного и импортного производства напрямую от производителей и с крупнейших мировых складов;
- Поставка более 17-ти миллионов наименований электронных компонентов;
- Поставка сложных, дефицитных, либо снятых с производства позиций;
- Оперативные сроки поставки под заказ (от 5 рабочих дней);
- Экспресс доставка в любую точку России;
- Техническая поддержка проекта, помощь в подборе аналогов, поставка прототипов;
- Система менеджмента качества сертифицирована по Международному стандарту ISO 9001;
- Лицензия ФСБ на осуществление работ с использованием сведений, составляющих государственную тайну;
- Поставка специализированных компонентов (Xilinx, Altera, Analog Devices, Intersil, Interpoint, Microsemi, Aeroflex, Peregrine, Syfer, Eurofarad, Texas Instrument, Miteq, Cobham, E2V, MA-COM, Hittite, Mini-Circuits, General Dynamics и др.);

Помимо этого, одним из направлений компании «ЭлектроПласт» является направление «Источники питания». Мы предлагаем Вам помощь Конструкторского отдела:

- Подбор оптимального решения, техническое обоснование при выборе компонента;
- Подбор аналогов;
- Консультации по применению компонента;
- Поставка образцов и прототипов;
- Техническая поддержка проекта;
- Защита от снятия компонента с производства.



#### Как с нами связаться

**Телефон:** 8 (812) 309 58 32 (многоканальный)

**Факс:** 8 (812) 320-02-42

**Электронная почта:** [org@eplast1.ru](mailto:org@eplast1.ru)

**Адрес:** 198099, г. Санкт-Петербург, ул. Калинина, дом 2, корпус 4, литера А.