

DIFFERENTIAL CONNECTOR

FCN-260(D) Series

RoHS Compliant

microGiGaCN™ Stacking Connector

■ FEATURES

- High speed matched impedance (100Ω) differential signal connector
- Low cross talk
- 2-step sequential mating of contacts
- Self alignment feature
- Hot plugable
- RoHS compliant

■ SPECIFICATIONS

Item	Specifications
Operating temperature range	-55° C to +105° C
Current rating	AC 0.1A (signal) AC 0.5A (ground)
Voltage rating	AC 30 V
Contact resistance	80m ohms max. (signal) 40m ohms max.(ground)
Insulation resistance	1000Mohms minimum
Dielectric withstanding voltage	AC 500V for 1 minute
Durability	100 cycles
Insertion force	50 N maximum (24 pair)
Withdrawl force	5 N minimum (24 pair)

■ MATERIALS

Item	Materials
Insulator	LCP Resin (UL94V-0)
Conductor	Copper Alloy
Plating	Contact: Au Plating (PAGOS) Au over Pd-Ni plating



Fujitsu's FCN-260(D) Differential Signal Connector

As network speeds increase, designers are moving to differential interconnects for network switches and hubs, as well as for connections between components in high-speed computer clusters, video systems, test equipment, and real-time medical equipment (MRI, etc.). Conventional connectors do not support the speed and signal integrity requirements of these applications. By implementing a connector specifically for high-speed, high-density, board-to-board differential applications, designers can take advantage of a differential interconnect instead of more costly fiber optic or coax alternatives.

Differential signals use two conductors to carry signals that are compliments of one another. This arrangement reduces noise effects because any noise introduced by interference or crosstalk appears in both signals (common-mode noise) and is ignored by differential

microGiGaCN™ FCN-260 (D) Series

receivers. With noise voltages less of a problem, differential signals can use a small voltage swing that switches between LOW and HIGH values extremely quickly --hence the appeal of differential signals for high-speed networking and clustering.

Differential connector characteristics can exceed the requirements of upcoming 1-Gbit applications and extend to next-generation applications at speeds upwards of 4.4 Gbps. As a result, system and board vendors who adopt such a connector can look forward to legacy usage that spans multiple product generations.

The signal transmission path of connectors has not always been a critical issue when choosing an interconnect method because the connector's electrical signal path is short compared to cables or printed circuit board assemblies. In applications utilizing high-frequency signals, however, connectors can have a significant effect on signal integrity. Connectors for high-speed applications must be designed to achieve optimal performance through the minimization of crosstalk and susceptibility to noise influences.

Differential signal applications

The shift from mainframe environments to networked client/server enterprises has made networks a critical bottleneck for improving system performance. Emerging technologies such as high-speed server farms, video conferencing, and greater use of graphical interfaces is pushing networks toward performance of 1 Gbit/sec and higher. The IEEE 802 committee is releasing 1.028-Gbit Ethernet standards to meet this requirement.

One of the key challenges for switch, hub, video equipment, and server manufacturers is to find a board-to-board connector system that allows signals to transfer at gigabit speeds over an affordable interconnect system that furnishes specific matched-impedance characteristics. Applications such as servers are now moving to extremely high-speed interfaces (often based on Fibre Channel) between computer backplanes and disk subsystems that require advance interconnects between boards. Similarly,

networking hubs incorporate many boards that must be interconnected via short-run cables. These internal cables often have to transfer data at speeds significantly higher than those of the actual network, so even today's 10/100-Mbit networks need high-speed internal interconnects with excellent signal integrity. In addition, any system that uses an external fiber optic connector probably requires an internal, board-to-board connector system that works at the highest possible speeds.

Fiber optic and coax interconnect systems obviously meet the internal performance requirements, but the cost is high. Differential interconnects meet both the performance and cost goals but until recently, no connectors were available that provided high-density connections at gigabit speeds. In addition, connector test methodologies from the past cannot give reliable and repeatable results of the differential connector's performance in high-speed systems. Therefore, new test methodologies must be developed based on the unique characteristics of these emerging high-speed applications.

High-speed differential interconnect characterization

In the past, connector manufacturers "de-embedded" the connector from the test PCB's to show just the electrical characteristics of the connector and did not include any parasitic effects associated with solder joints on a through hole contact lead, or the effects of the contact post (compliant or non-compliant pin) in a plated through hole. While this test methodology was acceptable for slower system speeds, today's differential interconnects demand much more focused attention on system and board effects.

The requirements for testing today's high-speed differential interconnects are demanding with good reason. Connectors and other traditionally "electrically small" components are no longer small when considering presently available signaling technologies with 100ps risetimes and multi-gigabit data rates. Among these requirements are very well-designed test boards needed for accurate measurement and characterization. This data is

microGiGaCN™ FCN-260 (D) Series

used to develop SPICE or other models and to provide detailed data to the design community. Typical high-frequency test boards designed by Fujitsu include:

- well-controlled impedance, matched-length test traces (with "real-world" widths and spacings)
- calibration/reference lines that mimic the test traces
- connector region entities (pads, pins, vias) that reflect actual system board implementations
- low discontinuity test connectors (these give access to the measurement equipment) of sufficient bandwidth to meet the testing needs (e.g. SMA, 55MB, etc.)

Differential pairs must be well-matched in order to minimize skew and maintain the proper impedance. Calibration lines of lengths "L" (where L is the length of the test traces between the article under test and the test connectors) and 2L provide the opportunity to calibrate out the board effects (if necessary) as well as to make "reference" measurements to test the goodness of an interconnect.

These reference measurements are especially important when determining transmission fidelity. Fujitsu Components attempts to use standard, commonly available FR-4 type board materials (better performers than some believe) whenever possible; however, there are times when so-called "low loss" board materials may be required, such as for long paths running at gigabit speeds.

In addition to very good test articles, test equipment must be selected that will provide for the measurements required at the bandwidths needed. Measurements may be completed for differential interconnects running at 100 Mbps, 625 Mbps, 1 Gbps, 2.5 Gbps or beyond depending on the system being designed. Fujitsu Components typically measures for single-ended and differential impedance (using a "TDR"), transmission fidelity, crosstalk, and eye pattern performance among other measures of quality. Typical transmission parameters quantified

include signal edge and amplitude losses, skews, propagation delays, and interconnect bandwidth. At times, frequency domain data (such as S-parameters) adds insight into these measurements and may be preferred by some customers. However, differential measurements in the frequency domain must be approached with caution and specialized knowledge.

microGiGaCN™ FCN-260 (D) Series

Figure 1

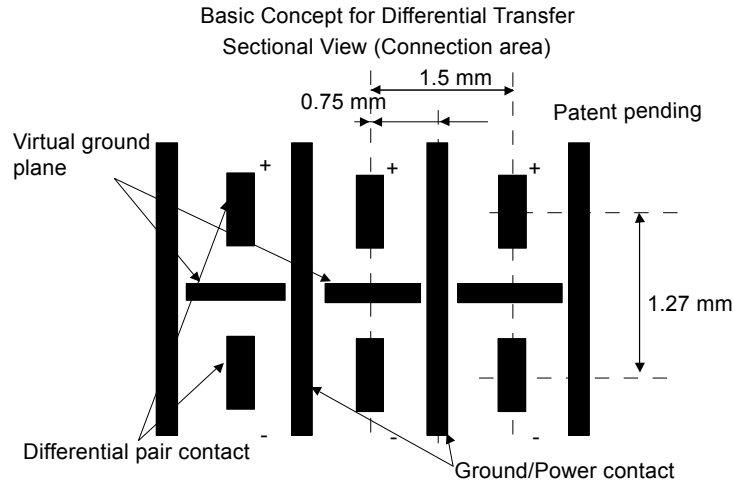
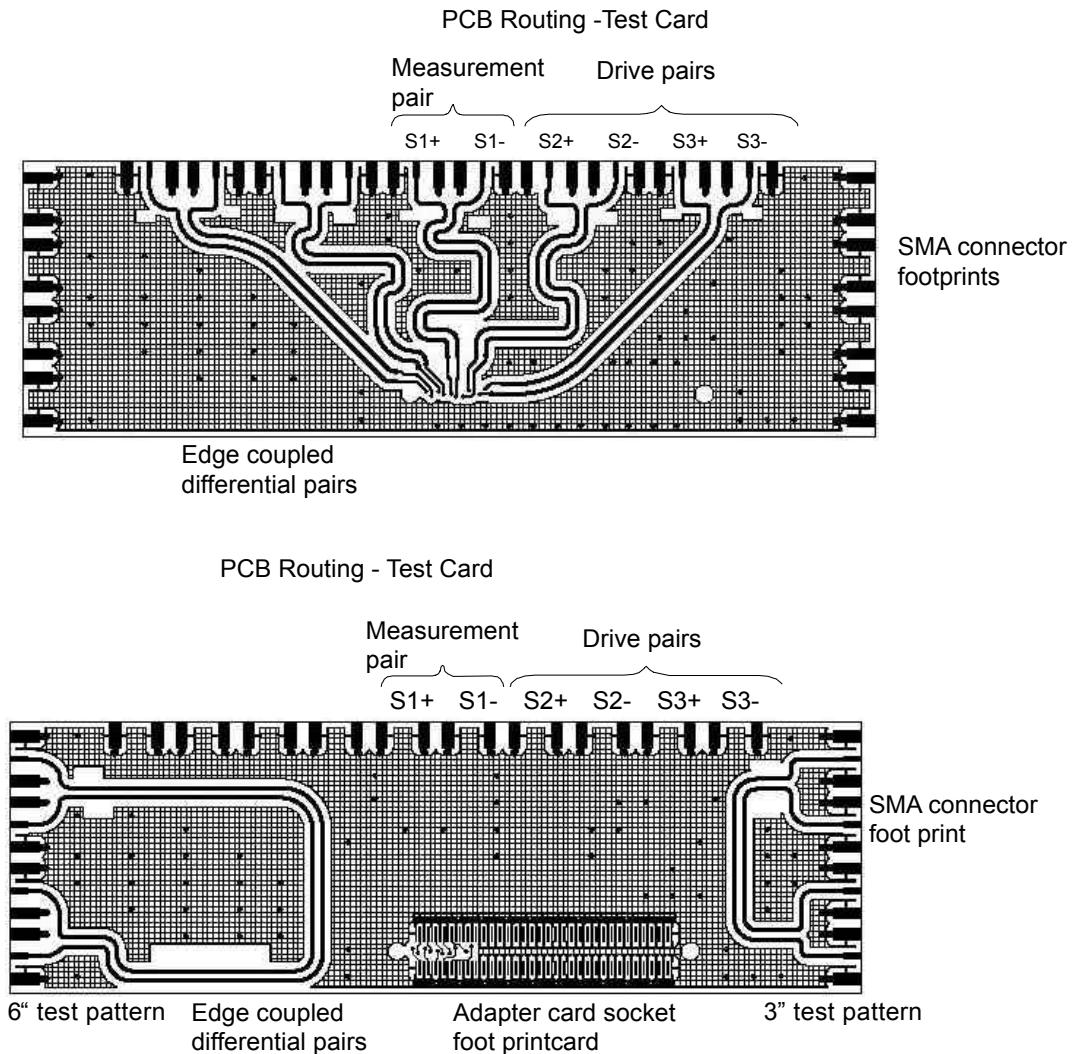

Figure 2



microGiGaCN™ FCN-260 (D) Series

TDR Results (Impedance Tr 50ps)

(Test Card + Stacking Connector)

(Area of connector)

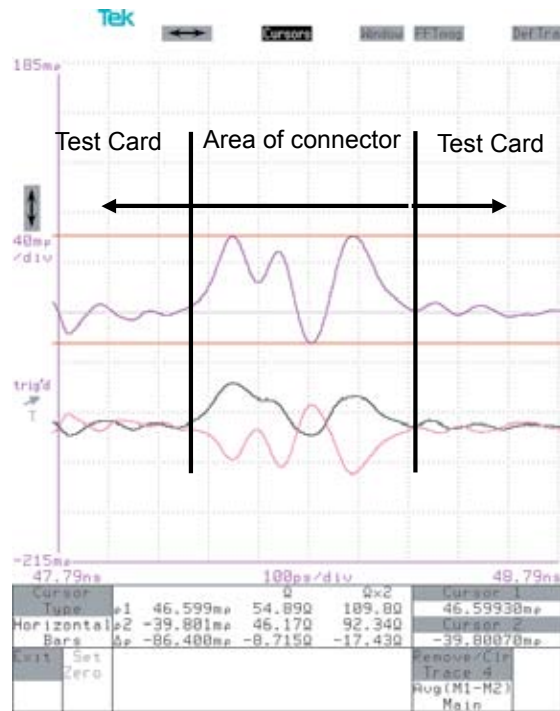
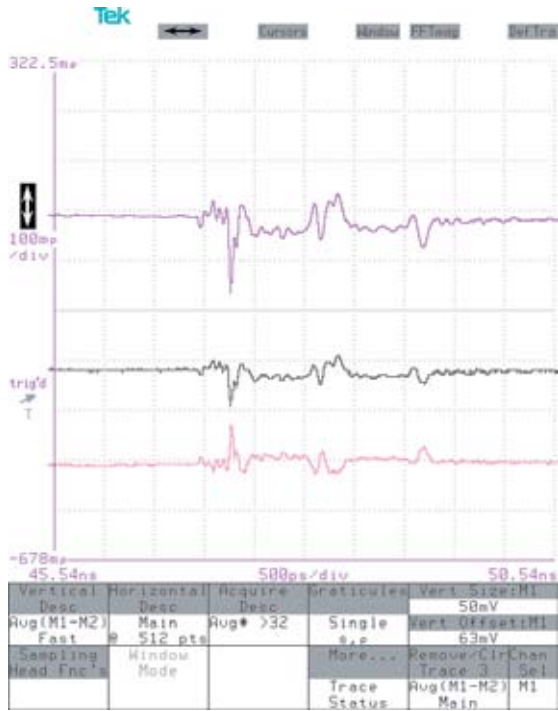

92.3 to 109.8 Ohms

TDR data includes connector footprint and test board

Single Pair Cross talk @ 50 ps T rise

Aggressor Differential Signal Components
(Tr=46.4 ps, 3 inches PCB calibration line)

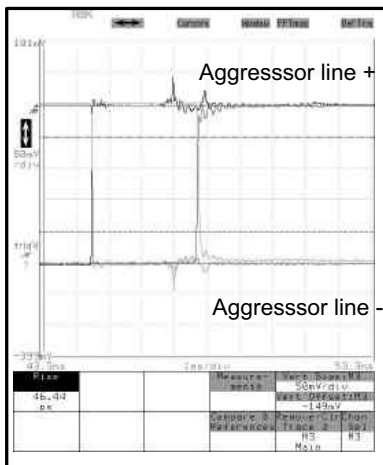

Data includes test SMA connector and test boards

Adjacent Connector Pair
Near End Cross talk
(~6.0 mV /500mV=1.2%)

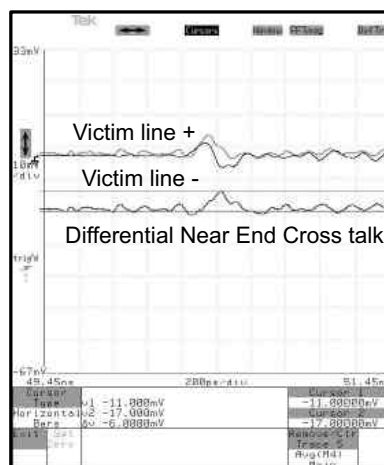

Adjacent Connector Pair
Far End Crosstalk
(~3.5 mV /500mV=0.7%)

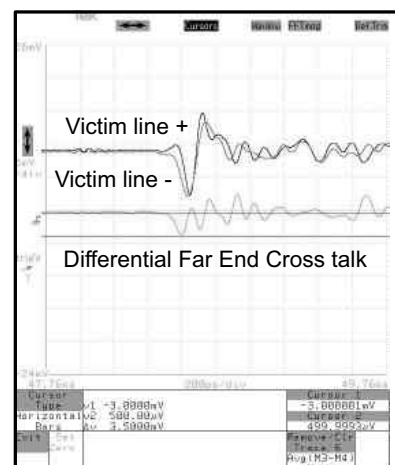

Cross talk data includes connector footprint and test board

microGiGaCN™ FCN-260 (D) Series

Attenuation(S21)

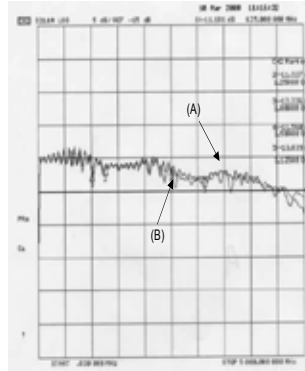
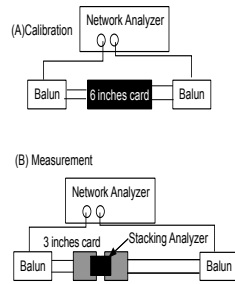

Balunis Picosecond Pulse Labs 5315.

Eye Pattern@625 Mbps

Measurement Input : 250mV

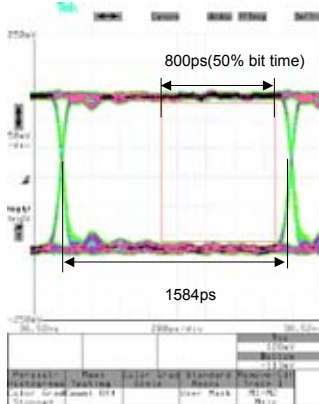

6 inches test card

Jitter: 16ps(Pk-Pk)
Height: 241mV

Pseudo-Random Bit Stream (PRBS) excitation from HP8133A-02 3GHz Pulse Generator

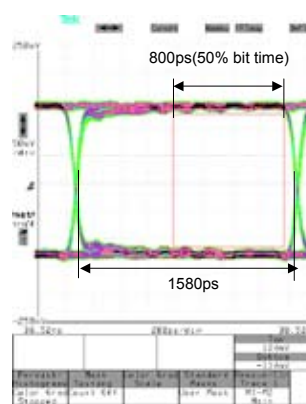

Test Card + Stacking Connector

Jitter: 20ps(Pk-Pk)
Height: 238 mV

All data includes connector footprint and test board

Eye Pattern@1.25 Gbps

Measurement Input : 250mV

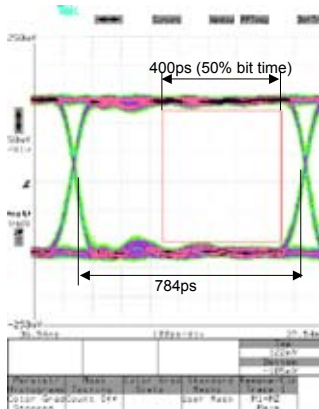

6 inches test card

Jitter: 16ps(Pk-Pk)
Height: 227 mV

Pseudo-Random Bit Stream (PRBS) excitation from HP8133A-02 3GHz Pulse Generator

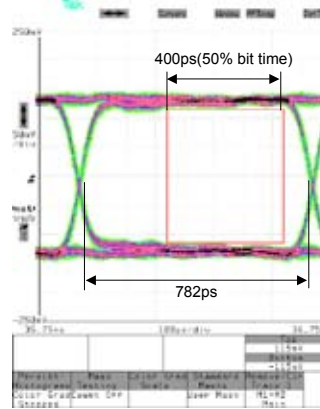

Test Card + Stacking Connector

Jitter: 18ps(Pk-Pk)
Height : 230mV

All data includes connector footprint and test board

microGiGaCN™ FCN-260 (D) Series

Eye Pattern@2.5 Gbps

Measurement Input : 250mV

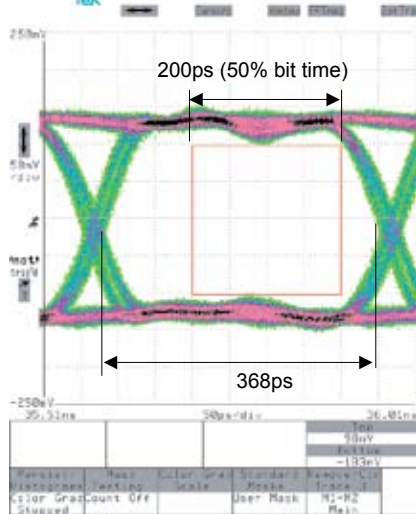

6 inches test card

Jitter: 32ps(Pk-Pk)

Height: 193 mV

Pseudo-Random Bit Stream (PRBS) excitation from HP8133A-02 3GHz Pulse Generator

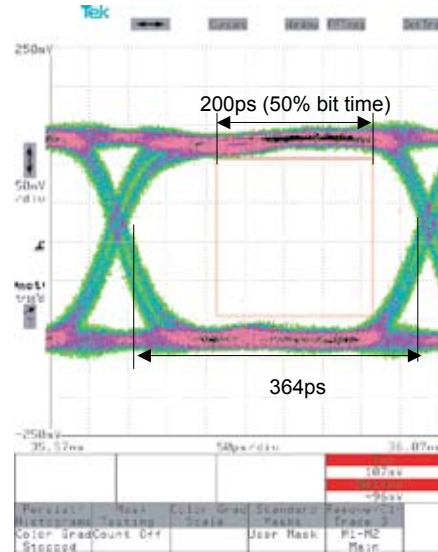

Test Card + Stacking Connector

Jitter: 36ps(Pk-Pk)

Height: 203 mV

All data includes connector footprint and test board

Eye Pattern @ 3.125 Gbps

Measurement Input: 250mV

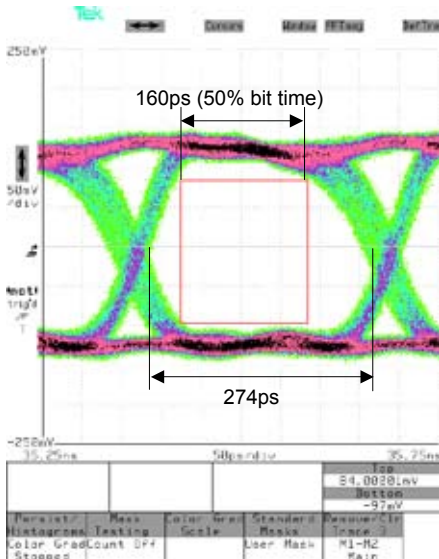

6 inches test card

Jitter: 46ps(Pk-Pk)

Height: 181mV

Pseudo-random Bit Stream (PRBS) excitation from HP8133A-02 3 GHz Pulse Generator

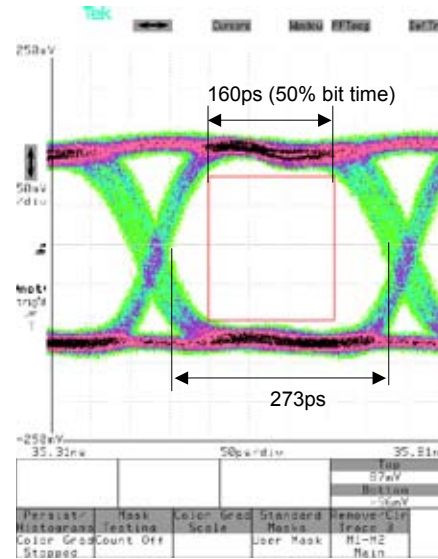

Test Card + Stacking Connector

Jitter: 47ps(Pk-Pk)

Height: 183 mV

All data includes connector footprint and test board

microGiGaCN™ FCN-260 (D) Series

■ STACKING SPECIFICATIONS

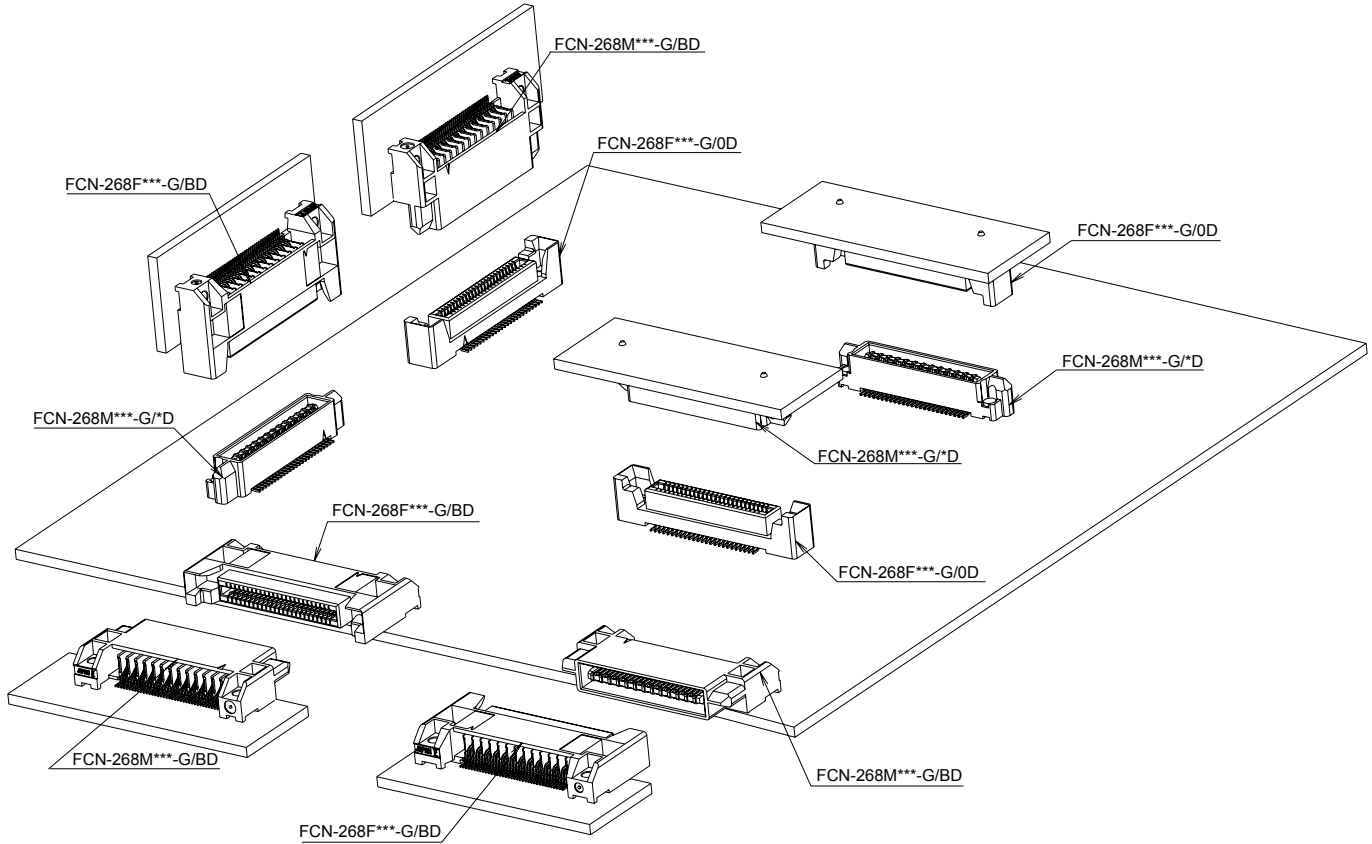

■ STACKING SPECIFICATIONS

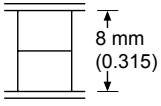
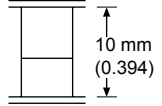
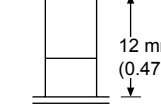
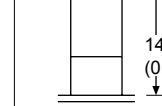
Board interval (mm)		8	10	12	14
Mounting dimensions		 8 mm (0.315)	 10 mm (0.394)	 12 mm (0.472)	 14 mm (0.551)
Part number	Socket	FCN-268F0xx-G/OD Note: This socket is used for all dimensions.			
	Plug	FCN-268Mxxx-G/OD	FCN-268Mxxx-G/1D	FCN-268Mxxx-G/2D	FCN-268Mxxx-G/3D

microGiGaCN™ FCN-260 (D) Series

BOARD TO BOARD, SOCKET

■ DIMENSIONS

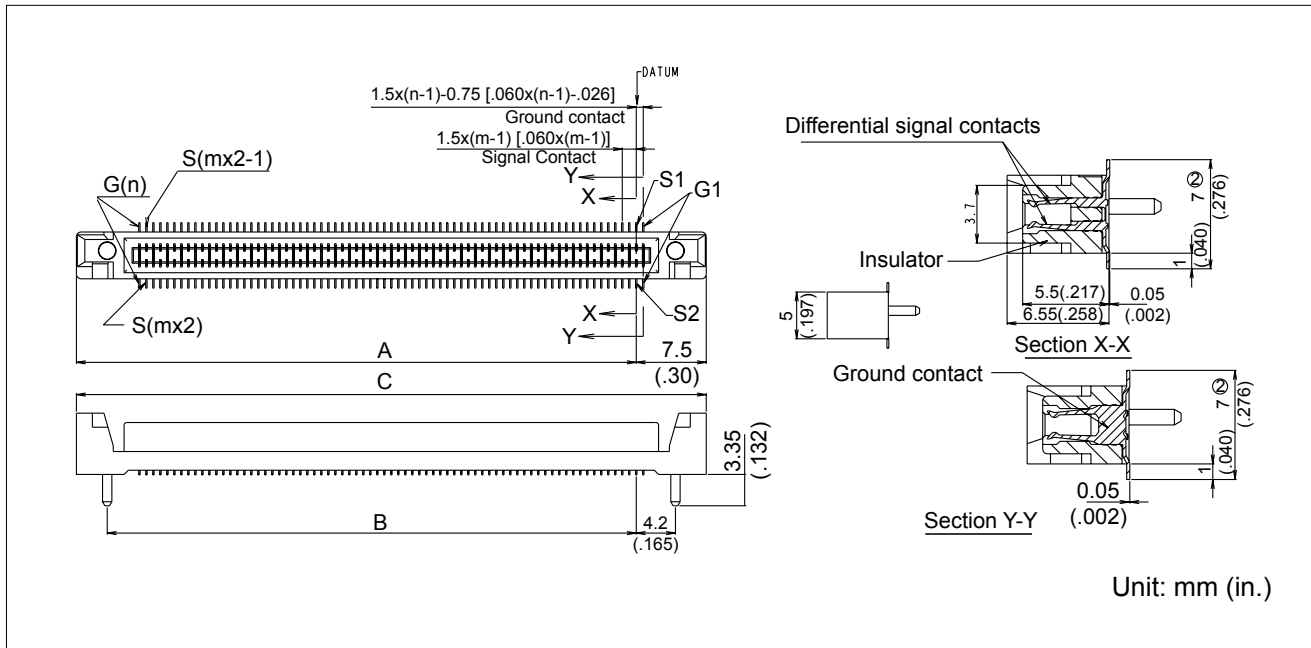

■ RECOMMENDED P.W.B. DIMENSION

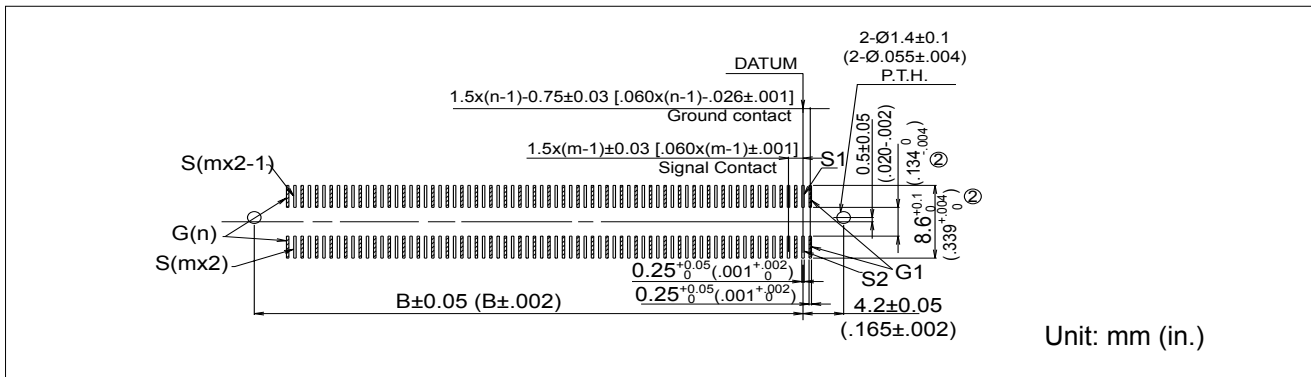

■ PART NUMBERS AND DIMENSIONS

Number of Differential Pair Signals	Number of Contacts	Part Number	Dimensions: mm (in.)				
			m	n	A	B	C
12	24 signal 13 ground	FCN-268F012-G/0D	1-12	1-13	24.0 (.944)	20.7 (.814)	31.5 (1.240)
24	48 signal 25 ground	FCN-268F024-G/0D	1-24	1-25	42.0 (1.653)	38.7 (1.523)	49.5 (1.948)
36	72 signal 37 ground	FCN-268F036-G/0D	1-36	1-37	60.0 (2.362)	56.7 (2.232)	67.5 (2.657)

microGiGaCN™ FCN-260 (D) Series

RIGHT ANGLE, SOCKET

■ DIMENSIONS

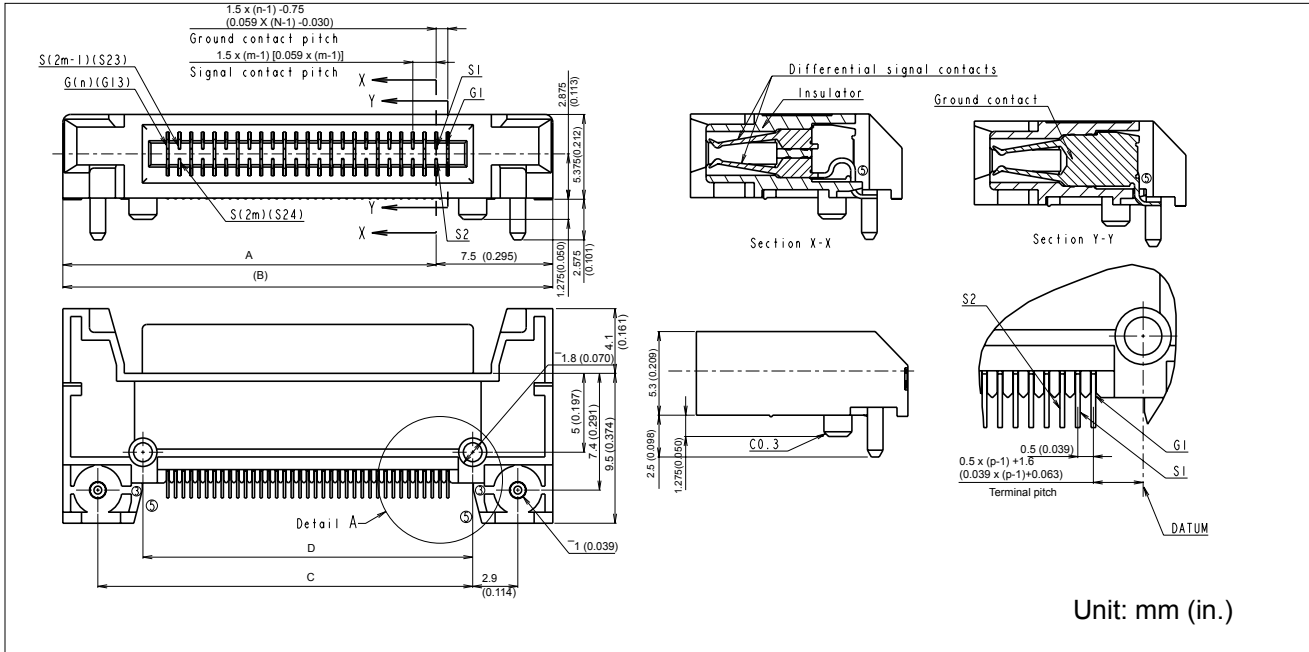

■ RECOMMENDED P.W.B. DIMENSION

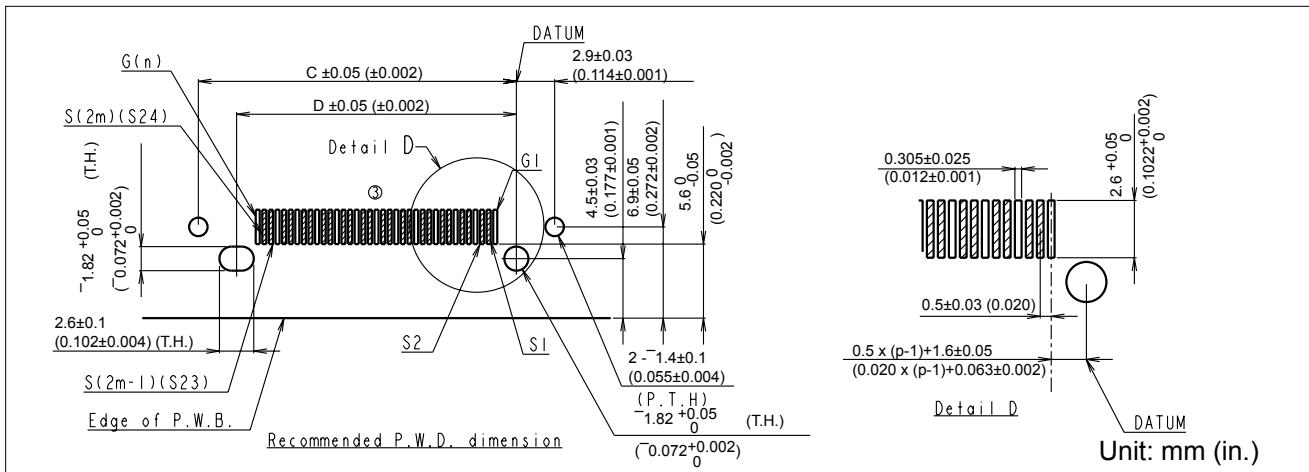

■ PART NUMBERS AND DIMENSIONS

Number of Differential Pair Signals	Part Number	Dimensions: mm (in.)						
		m	n	p	A	(B)	C	D
12	FCN-268F012-G/BD	1-12	1-13	1-37	24.0 (0.941)	31.5 (1.240)	24.1 (0.949)	21.2 (0.835)
24	FCN-268F024-G/BD	1-24	1-25	1-73	42.0 (1.654)	49.5 (1.949)	42.1 (1.657)	39.2 (1.543)
36	FCN-268F036-G/BD	1-36	1-37	1-109	60.0 (2.362)	67.5 (2.657)	60.1 (2.366)	57.2 (2.252)

microGiGaCN™ FCN-260 (D) Series

BOARD TO BOARD, PLUG, STACKING HEIGHT 8 mm

■ DIMENSIONS

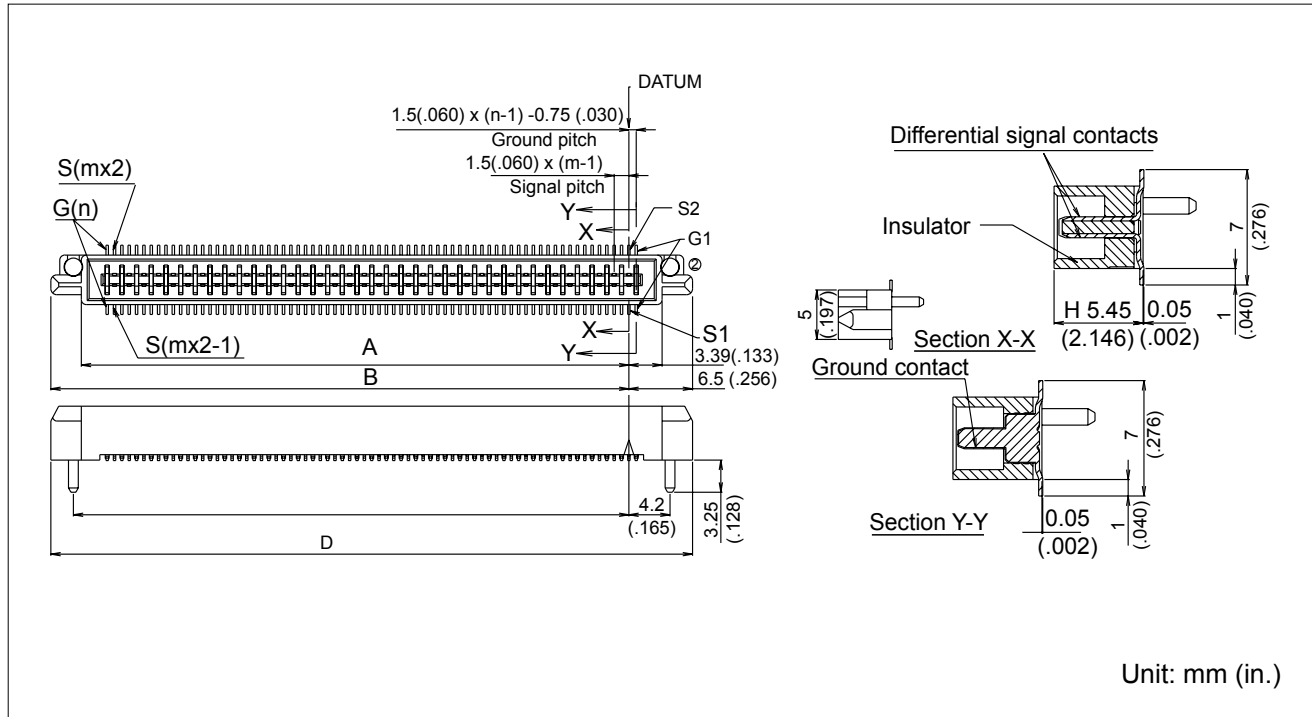

■ RECOMMENDED P.W.B. DIMENSION

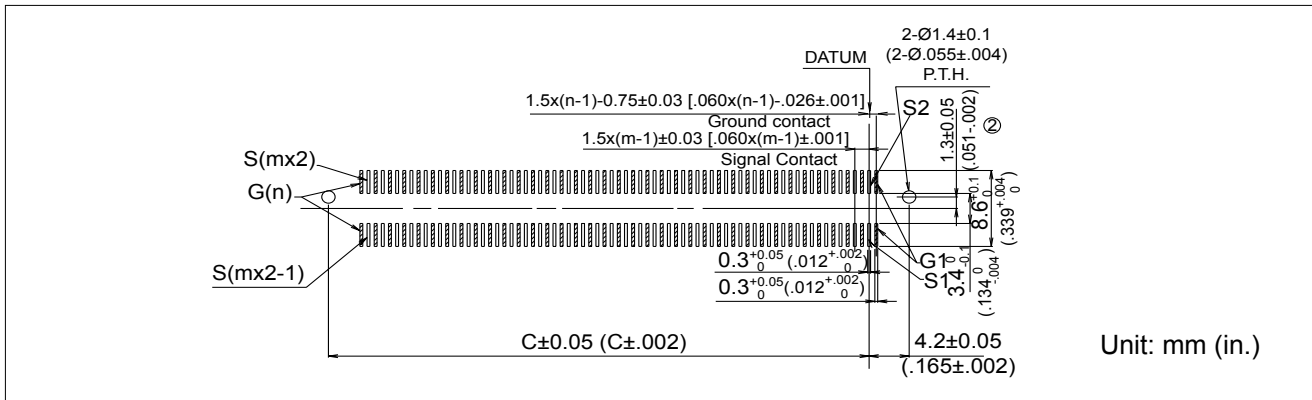

■ PART NUMBERS AND DIMENSIONS

Number of Differential Pair Signals	Number of Contacts	Part Number	Dimensions: mm (in.)					
			m	n	A	B	C	D
12	24 signal 13 ground	FCN-268M012-G/0D	1-12	1-13	19.89 (.783)	23.0 (.906)	20.7 (.814)	29.5 (1.161)
24	48 signal 25 ground	FCN-268M024-G/0D	1-24	1-25	37.89 (1.491)	41.0 (1.614)	38.7 (1.523)	47.5 (1.870)
36	72 signal 37 ground	FCN-268M036-G/0D	1-36	1-37	55.89 (2.200)	59.0 (2.322)	56.7 (2.232)	65.5 (2.578)

microGiGaCN™ FCN-260 (D) Series

BOARD TO BOARD, PLUG, STACKING HEIGHT 10mm

■ DIMENSIONS

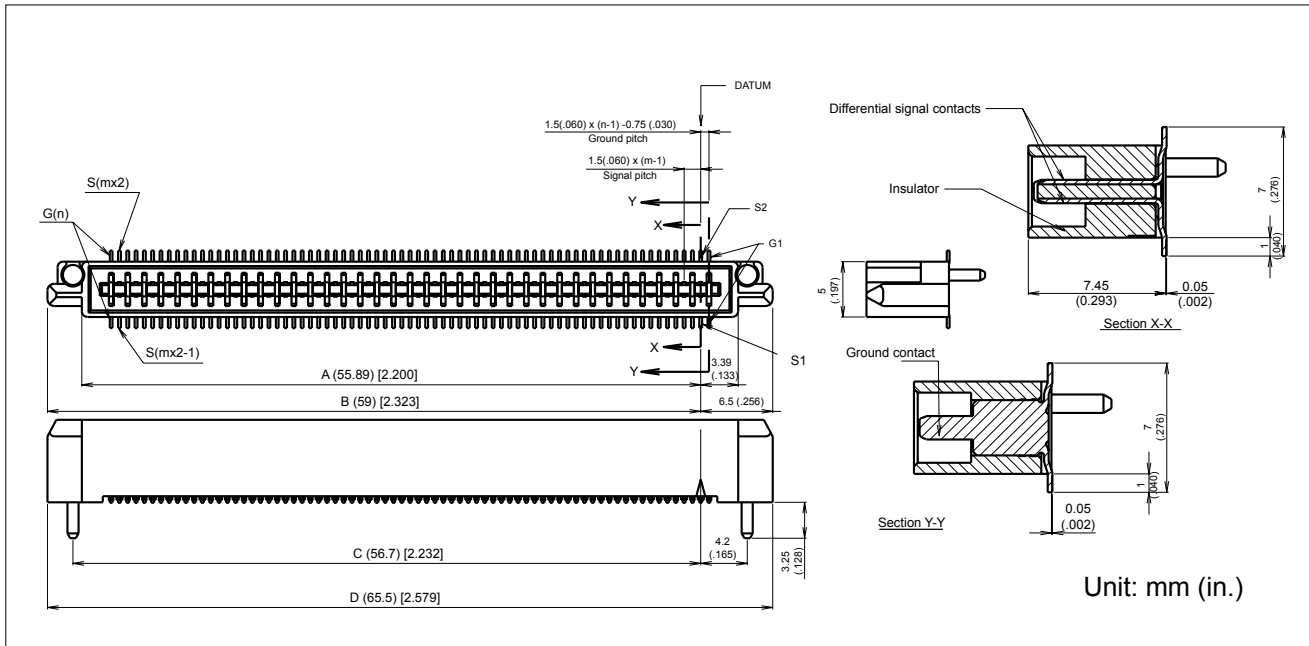

■ RECOMMENDED P.W.B. DIMENSION

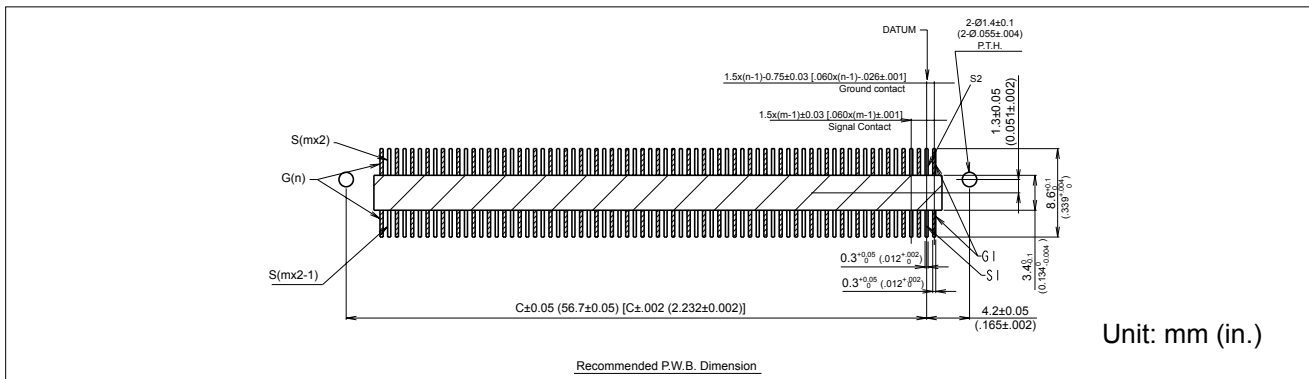

■ PART NUMBERS AND DIMENSIONS

Number of Differential Pair Signals	Number of Contacts	Part Number	Dimensions: mm (in.)					
			m	n	A	B	C	D
12	24 signal 13 ground	FCN-268M012-G/1D	1-12	1-13	19.89 (.783)	23.0 (.906)	20.7 (.814)	29.5 (1.161)
24	48 signal 25 ground	FCN-268M024-G/1D	1-24	1-25	37.89 (1.491)	41.0 (1.614)	38.7 (1.523)	47.5 (1.870)
36	72 signal 37 ground	FCN-268M036-G/1D	1-36	1-37	55.89 (2.200)	59.0 (2.322)	56.7 (2.232)	65.5 (2.578)

microGiGaCN™ FCN-260 (D) Series

BOARD TO BOARD, PLUG, STACKING HEIGHT 12mm

■ DIMENSIONS

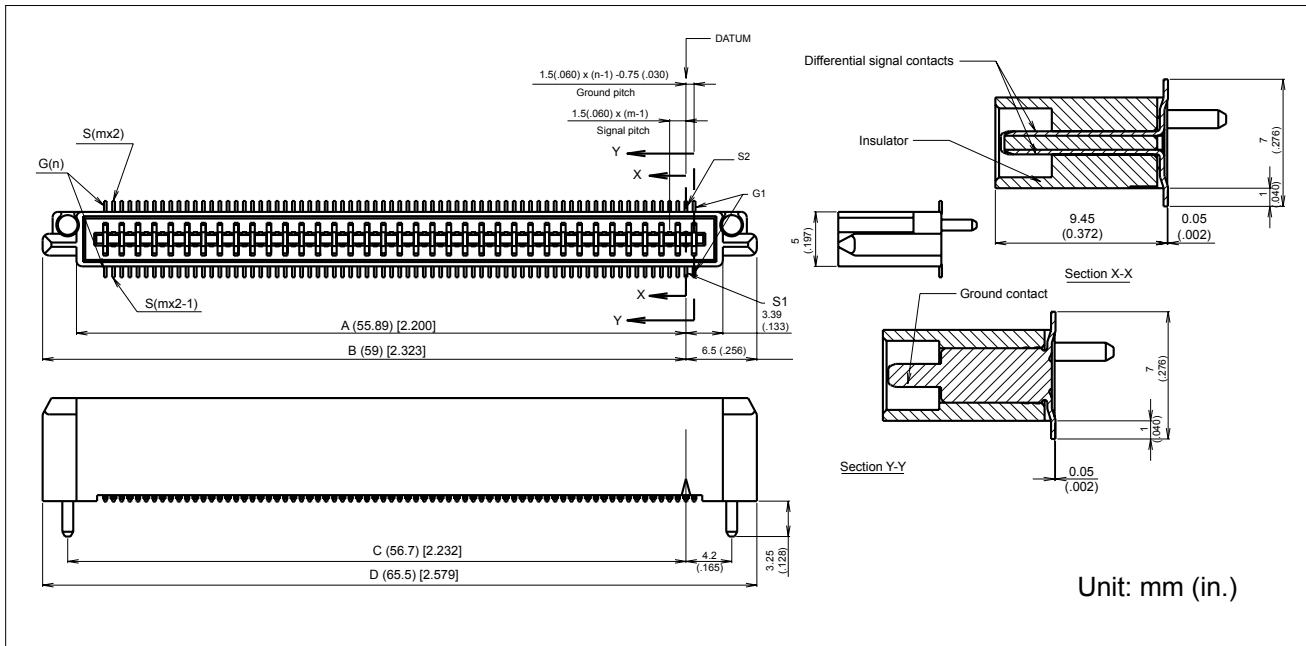

■ RECOMMENDED P.W.B. DIMENSION

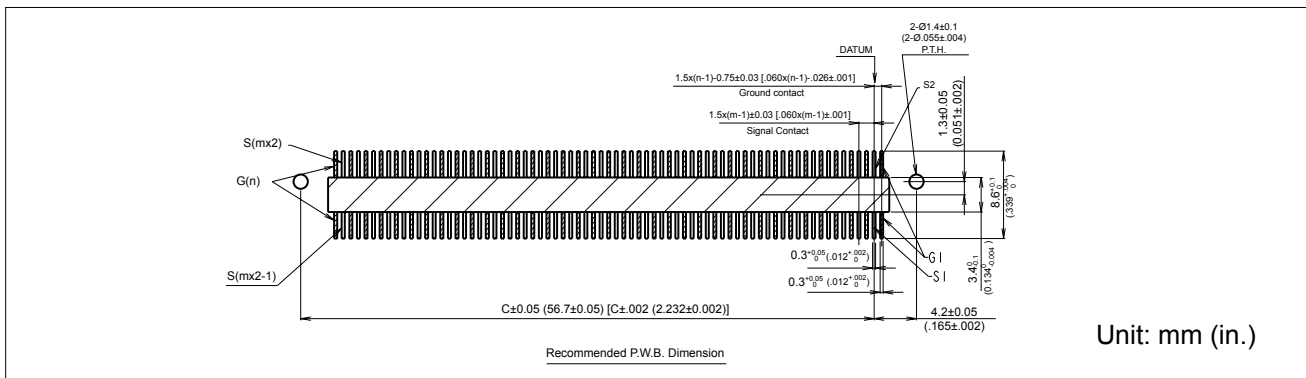

■ PART NUMBERS AND DIMENSIONS

Number of Differential Pair Signals	Number of Contacts	Part Number	Dimensions: mm (in.)					
			m	n	A	B	C	D
12	24 signal 13 ground	FCN-268M012-G/2D	1-12	1-13	19.89 (.783)	23.0 (.906)	20.7 (.814)	29.5 (1.161)
24	48 signal 25 ground	FCN-268M024-G/2D	1-24	1-25	37.89 (1.491)	41.0 (1.614)	38.7 (1.523)	47.5 (1.870)
36	72 signal 37 ground	FCN-268M036-G/2D	1-36	1-37	55.89 (2.200)	59.0 (2.322)	56.7 (2.232)	65.5 (2.578)

microGiGaCN™ FCN-260 (D) Series

BOARD TO BOARD, PLUG, STACKING HEIGHT 14mm

■ DIMENSIONS

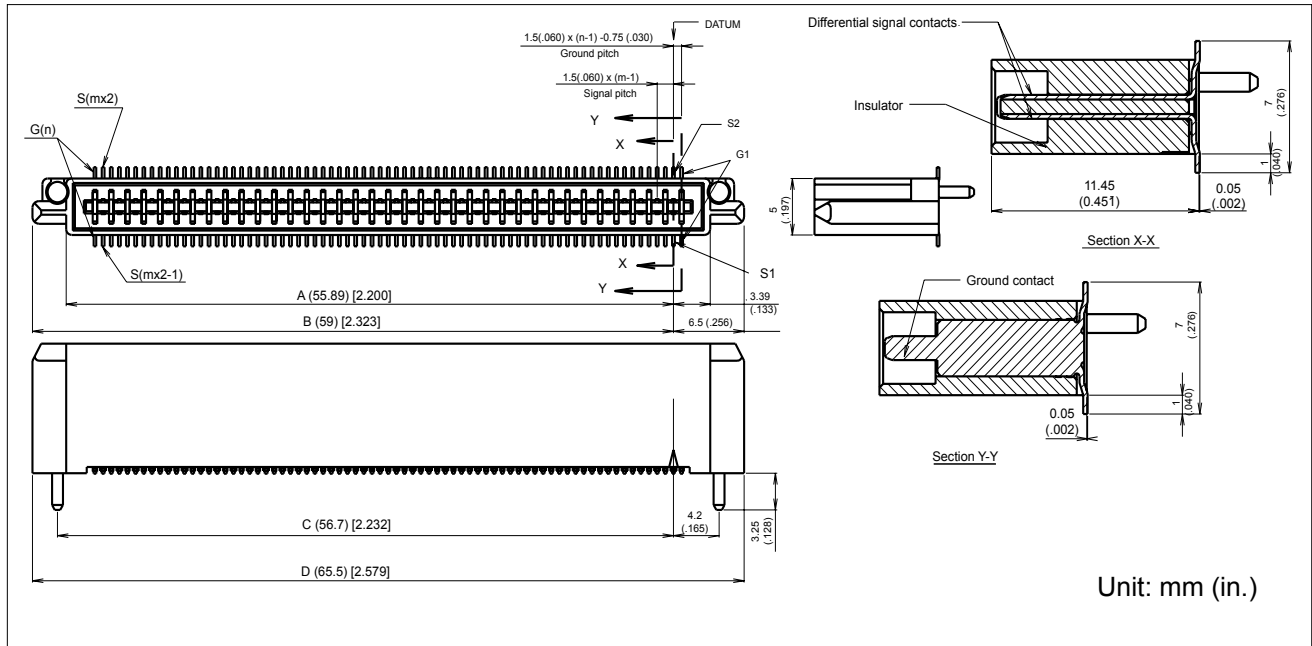

■ RECOMMENDED P.W.B. DIMENSION

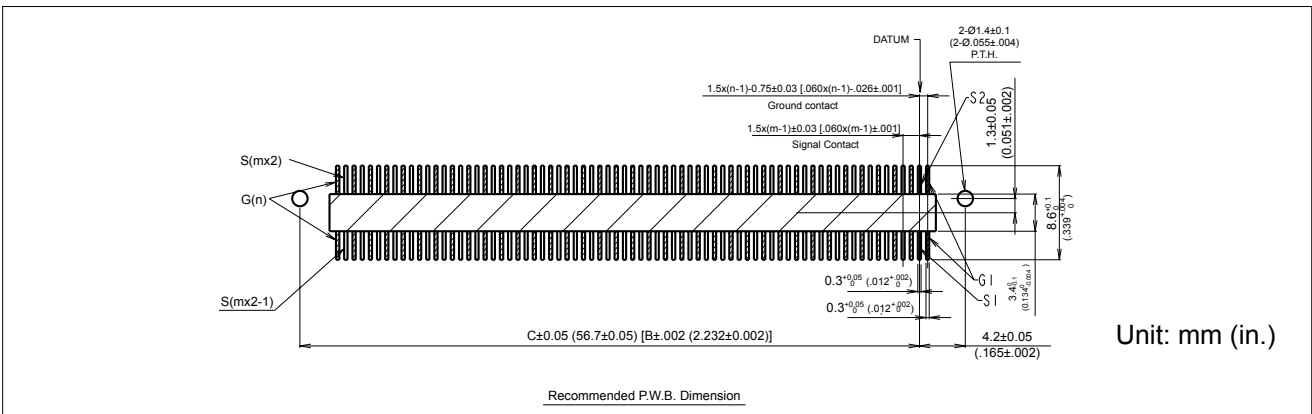

■ PART NUMBERS AND DIMENSIONS

Number of Differential Pair Signals	Number of Contacts	Part Number	Dimensions: mm (in.)					
			m	n	A	B	C	D
12	24 signal 13 ground	FCN-268M012-G/3D	1-12	1-13	19.89 (.783)	23.0 (.906)	20.7 (.814)	29.5 (1.161)
24	48 signal 25 ground	FCN-268M024-G/3D	1-24	1-25	37.89 (1.491)	41.0 (1.614)	38.7 (1.523)	47.5 (1.870)
36	72 signal 37 ground	FCN-268M036-G/3D	1-36	1-37	55.89 (2.200)	59.0 (2.322)	56.7 (2.232)	65.5 (2.578)

microGiGaCN™ FCN-260 (D) Series

BOARD TO BOARD, PLUG, RIGHT ANGLE

■ DIMENSIONS

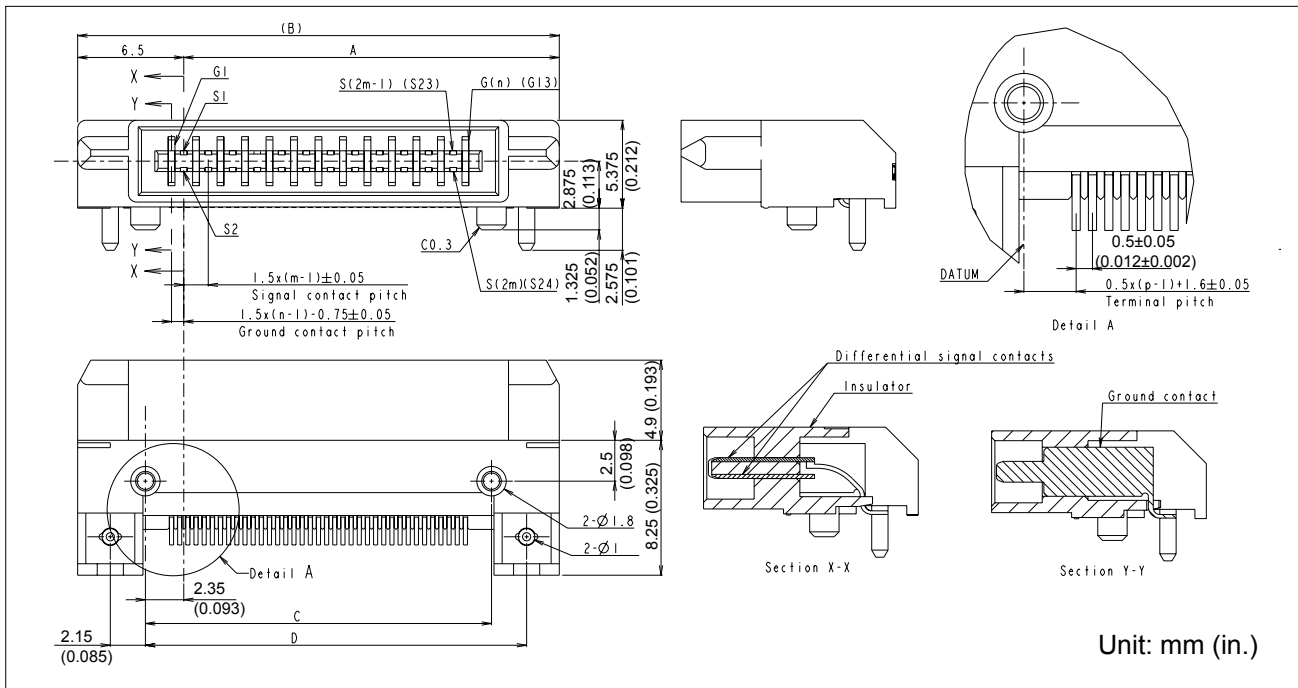

■ RECOMMENDED P.W.B. DIMENSION

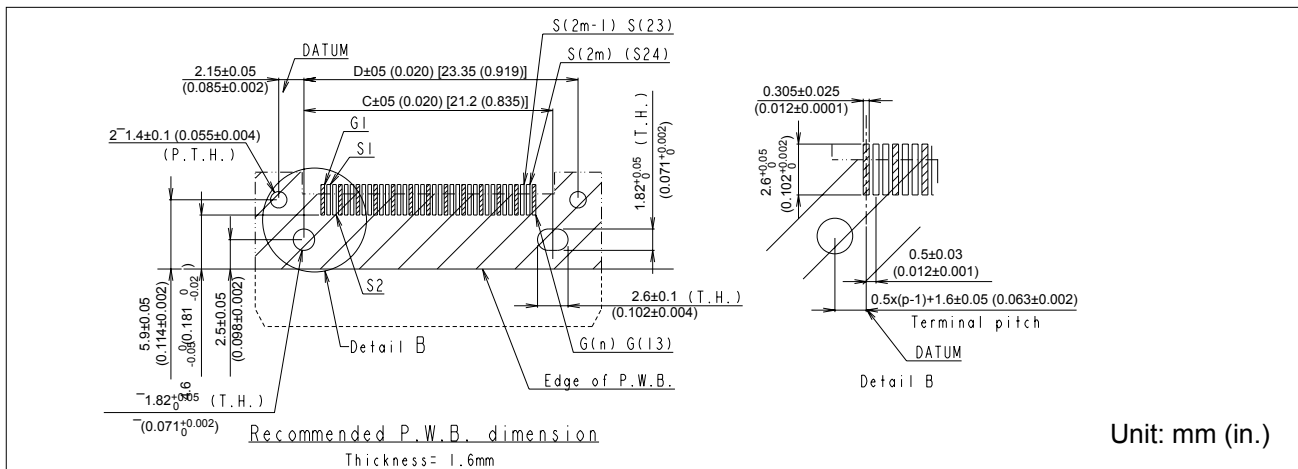

■ PART NUMBERS AND DIMENSIONS

Number of Differential Pair Signals	Number of Contacts	Part Number	Dimensions: mm (in.)						
			m	n	p	A	(B)	C	D
12	24 signal 13 ground	FCN-268M012-G/BD	1-12	1-13	1-37	19.89 (.783)	29.5 (1.161)	21.2 (0.835)	23.35 (0.919)
24	48 signal 25 ground	FCN-268M024-G/BD	1-24	1-25	1-73	37.89 (1.491)	47.5 (1.870)	39.2 (1.543)	41.35 (1.628)
36	72 signal 37 ground	FCN-268M036-G/BD	1-36	1-37	1-1-0-	55.89 (2.200)	65.5 (2.579)	57.2 (2.252)	59.35 (2.237)

microGiGaCN™ FCN-260 (D) Series

Fujitsu Components International Headquarter Offices

Japan

Fujitsu Component Limited
Gotanda-Chuo Building
3-5, Higashigotanda 2-chome, Shinagawa-ku
Tokyo 141, Japan
Tel: (81-3) 5449-7010
Fax: (81-3) 5449-2626
Email: promothq@ft.ed.fujitsu.com
Web: www.fcl.fujitsu.com

North and South America

Fujitsu Components America, Inc.
250 E. Caribbean Drive
Sunnyvale, CA 94089 U.S.A.
Tel: (1-408) 745-4900
Fax: (1-408) 745-4970
Email: components@us.fujitsu.com
Web: <http://www.fujitsu.com/us/services/edevices/components/>

Europe

Fujitsu Components Europe B.V.
Diamantlaan 25
2132 WV Hoofddorp
Netherlands
Tel: (31-23) 5560910
Fax: (31-23) 5560950
Email: info@fceu.fujitsu.com
Web: emea.fujitsu.com/components/

Asia Pacific

Fujitsu Components Asia Ltd.
102E Pasir Panjang Road
#01-01 Citilink Warehouse Complex
Singapore 118529
Tel: (65) 6375-8560
Fax: (65) 6273-3021
Email: fcalfcal.fujitsu.com
Web: <http://www.fujitsu.com/sg/services/micro/components/>

©2008 Fujitsu Components America, Inc. All rights reserved. All trademarks or registered trademarks are the property of their respective owners.

Fujitsu Components America or its affiliates do not warrant that the content of datasheet is error free. In a continuing effort to improve our products Fujitsu Components America, Inc. or its affiliates reserve the right to change specifications/datasheets without prior notice.
Rev. September 24, 2008



Компания «ЭлектроПласт» предлагает заключение долгосрочных отношений при поставках импортных электронных компонентов на взаимовыгодных условиях!

Наши преимущества:

- Оперативные поставки широкого спектра электронных компонентов отечественного и импортного производства напрямую от производителей и с крупнейших мировых складов;
- Поставка более 17-ти миллионов наименований электронных компонентов;
- Поставка сложных, дефицитных, либо снятых с производства позиций;
- Оперативные сроки поставки под заказ (от 5 рабочих дней);
- Экспресс доставка в любую точку России;
- Техническая поддержка проекта, помощь в подборе аналогов, поставка прототипов;
- Система менеджмента качества сертифицирована по Международному стандарту ISO 9001;
- Лицензия ФСБ на осуществление работ с использованием сведений, составляющих государственную тайну;
- Поставка специализированных компонентов (Xilinx, Altera, Analog Devices, Intersil, Interpoint, Microsemi, Aeroflex, Peregrine, Syfer, Eurofarad, Texas Instrument, Miteq, Cobham, E2V, MA-COM, Hittite, Mini-Circuits, General Dynamics и др.);

Помимо этого, одним из направлений компании «ЭлектроПласт» является направление «Источники питания». Мы предлагаем Вам помощь Конструкторского отдела:

- Подбор оптимального решения, техническое обоснование при выборе компонента;
- Подбор аналогов;
- Консультации по применению компонента;
- Поставка образцов и прототипов;
- Техническая поддержка проекта;
- Защита от снятия компонента с производства.



Как с нами связаться

Телефон: 8 (812) 309 58 32 (многоканальный)

Факс: 8 (812) 320-02-42

Электронная почта: org@eplast1.ru

Адрес: 198099, г. Санкт-Петербург, ул. Калинина, дом 2, корпус 4, литера А.