

NHD-240128WG-ATFH-VZ#

Graphic Liquid Crystal Display Module

NHD-	Newhaven Display
240128-	240 x 128 pixels
WG-	Display Type: Graphic
A-	Model
T-	White LED Backlight
F-	FSTN (+)
H-	Transflective, 6:00 view, Wide Temperature (-20°C ~+70°C)
VZ#-	Built-in Negative Voltage
	RoHS Compliant

Newhaven Display International, Inc.

2511 Technology Drive, Suite 101

Elgin IL, 60124

Ph: 847-844-8795

Fax: 847-844-8796

www.newhavendisplay.com

nhtech@newhavendisplay.com

nhsales@newhavendisplay.com

Document Revision History

Revision	Date	Description	Changed by
0	4/28/2010	User guide reformat	MC
1	2/9/2011	Pin description updated	AK
2	4/26/2011	Electrical characteristics updated	AK
3	4/13/2012	Mechanical drawing updated	AK

Functions and Features

- 240 x 128 pixels
- Built-in RA6963 Controller
- +5.0V power supply
- RoHS Compliant

Mechanical Drawing

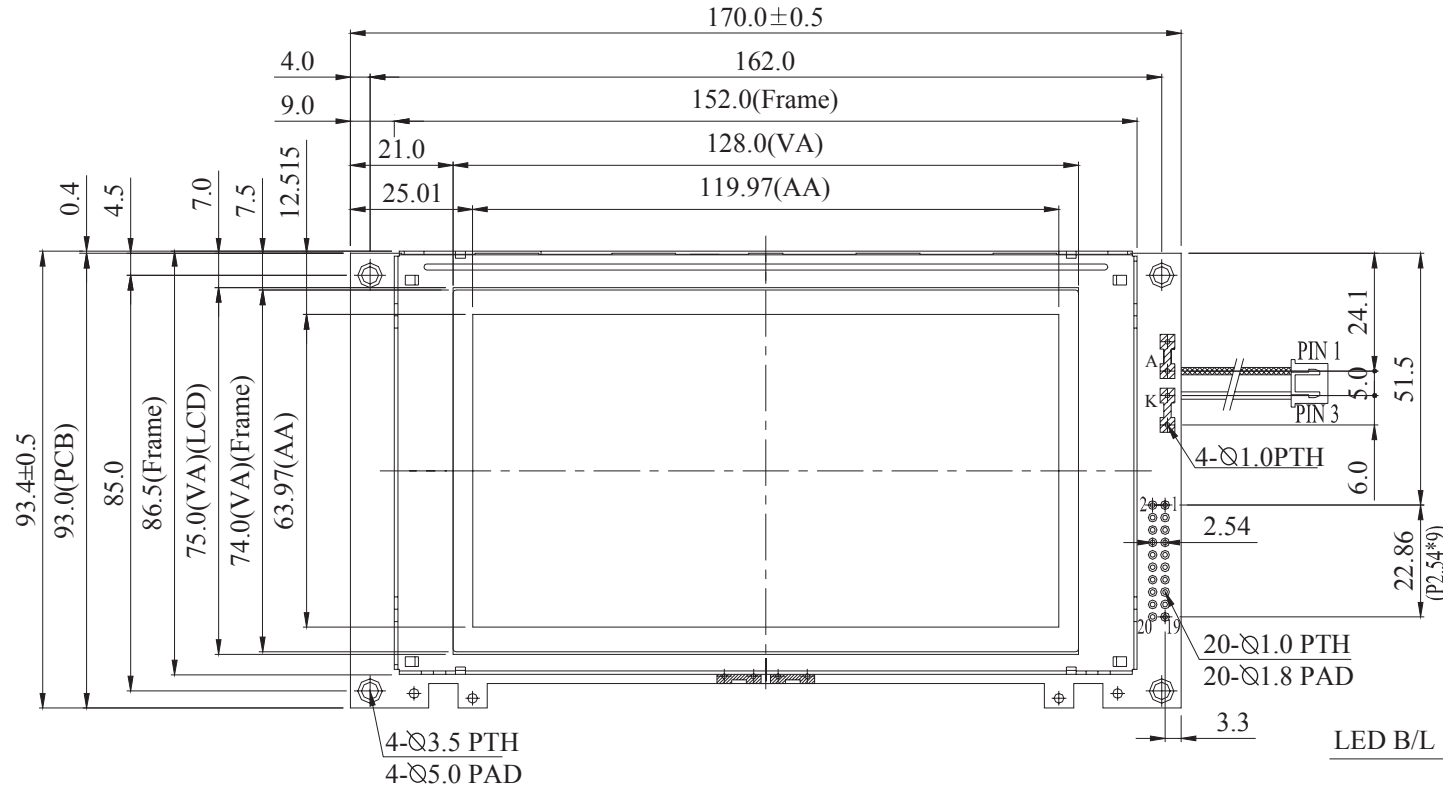

PIN NO.	SYMBOL
1	FGND
2	VSS
3	VDD
4	V0
5	$\overline{\text{WR}}$
6	RD
7	$\overline{\text{CE}}$
8	C/D
9	VEE
10	$\overline{\text{RESET}}$
11	DB0
12	DB1
13	DB2
14	DB3
15	DB4
16	DB5
17	DB6
18	DB7
19	FS
20	RV

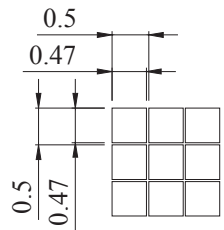

DOT SIZE
 SCALE 10/1

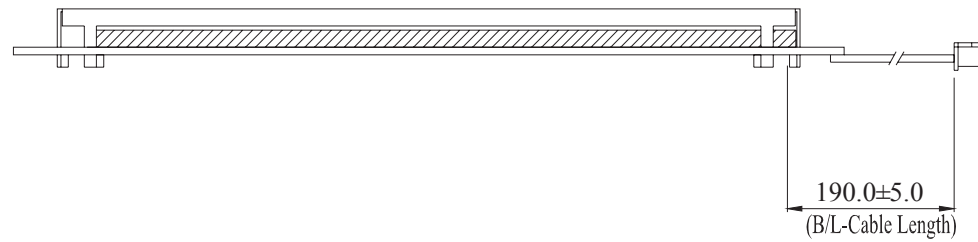

Newhaven Display

NHD-240128WG-ATFH-VZ#

Pin Description and Wiring Diagram

Pin No.	Symbol	External Connection	Function Description
1	FGND	Power Supply	Frame Ground
2	VSS	Power Supply	Ground
3	VDD	Power Supply	Power supply for logic (+5.0V)
4	VO	Adj Power Supply	Power supply for contrast (approx. -13.0V)
5	\overline{WR}	MPU	Read/Write select signal, R/W=1: Read R/W: =0: Write
6	\overline{RD}	MPU	Active LOW read
7	\overline{CE}	MPU	Active LOW chip select signal
8	C/D	MPU	Register select signal. CD=1: Command, CD=0: Data
9	VEE	Power Supply	Negative voltage output (-22V)
10	RESET	MPU	Active LOW reset signal
11-18	DB0~DB7	MPU	Bi-directional three-state data bus lines.
19	FS	Power Supply	Font select signal. H:6x8, L:8x8
20	RV	MPU	Display mode signal. RV=1: Reverse display, RV=0: normal

Recommended LCD connector: 20 pin, 2.54mm pitch pins

Backlight connector: JST p/n: XHP-3 **Mates with:** JST p/n: B 3B-XH-A

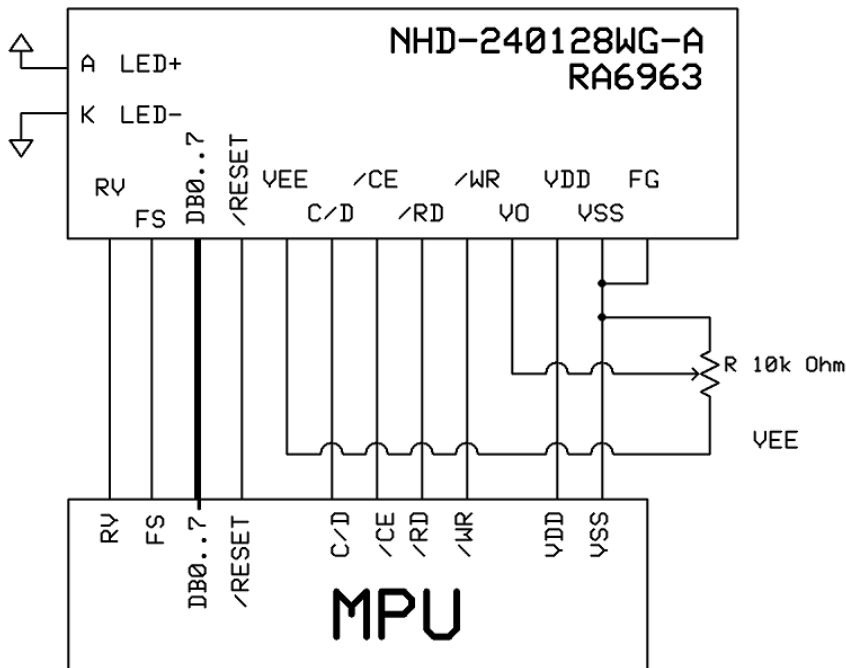

Electrical Characteristics

Item	Symbol	Condition	Min.	Typ.	Max.	Unit
Operating Temperature Range	Top	Absolute Max	-20	-	+70	°C
Storage Temperature Range	Tst	Absolute Max	-30	-	+80	°C
Supply Voltage	VDD		4.75	5.0	5.25	V
Supply Current	IDD	Ta=25°C, VDD=5.0V	-	23.0	-	mA
Supply for LCD (contrast)	VDD-V0	Ta=25°C	16.3	18.0	20.1	V
"H" Level input	VIH		VDD-2.2	-	VDD	V
"L" Level input	VIL	-	0	-	0.8	V
"H" Level output	VOH	-	VDD-0.3	-	VDD	V
"L" Level output	VOL	-	0	-	0.3	V
Backlight Supply Voltage	VLED		3.4	3.5	3.6	V
Backlight Supply Current	ILED	VLED=3.5V	98	112	125	mA
Backlight Lifetime		ILED=160mA	-	50,000	-	Hrs
Backlight Brightness	IV	ILED=160mA	180	230	-	CD/M ²

Optical Characteristics

Item	Symbol	Condition	Min.	Typ.	Max.	Unit
Viewing Angle - Vertical	AV	Cr ≥ 2	-30	-	60	°
Viewing Angle - Horizontal	AH	Cr ≥ 2	-45	-	45	°
Contrast Ratio	Cr		-	5	-	-
Response Time (rise)	Tr	-	-	200	300	ms
Response Time (fall)	Tf	-	-	200	300	ms

Controller Information

Built-in RA6963. Download specification at http://www.newhavendisplay.com/app_notes/RA6963.pdf

Table of Commands

Command	Code	D1	D2	Function
Registers Setting	00100001	X address	Y address	Set cursor pointer
	00100010	Data	00h	Set Offset Register
	00100100	Low address	High address	Set Address pointer
Set Control Word	01000000	Low address	High address	Set Text Home Address
	01000001	Columns	00h	Set Text Area
	01000010	Low address	High address	Set Graphic Home Address
	01000011	Columns	00h	Set Graphic Area
Mode Set	1000X000	--	--	OR mode
	1000X001	--	--	EXOR mode
	1000X011	--	--	AND mode
	1000X100	--	--	Text Attribute mode
	10000XXX	--	--	Internal CG ROM mode
	10001XXX	--	--	External CG RAM mode
Display Mode	10010000	--	--	Display off
	1001XX10	--	--	Cursor on, blink off
	1001XX11	--	--	Cursor on, blink on
	100101XX	--	--	Text on, graphic off
	100110XX	--	--	Text off, graphic on
	100111XX	--	--	Text on, graphic on
Cursor Pattern Select	10100000	--	--	1-line cursor
	10100001	--	--	2-line cursor
	10100010	--	--	3-line cursor
	10100011	--	--	4-line cursor
	10100100	--	--	5-line cursor
	10100101	--	--	6-line cursor
	10100110	--	--	7-line cursor
	10100111	--	--	8-line cursor
Data Read/Write	11000000	Data	--	Data Write and Increment ADP
	11000001	--	--	Data Read and Increment ADP
	11000010	Data	--	Data Write and Decrement ADP
	11000011	--	--	Data Read and Decrement ADP
	11000100	Data	--	Data Write and Non-variable ADP
	11000101	--	--	Data Read and Non-variable ADP
Data auto Read/Write	10110000	--	--	Set Data Auto Write
	10110001	--	--	Set Data Auto Read
	10110010	--	--	Auto Reset
Screen Peek	11100000	--	--	Screen Peek
Screen Copy	11101000			Screen Copy
Bit Set/Reset	11110XXX	--	--	Bit Reset
	11111XXX	--	--	Bit Set
	1111X000	--	--	Bit 0 (LSB)
	1111X001	--	--	Bit 1
	1111X010	--	--	Bit 2
	1111X011	--	--	Bit 3
	1111X100	--	--	Bit 4
	1111X101	--	--	Bit 5
	1111X110	--	--	Bit 6
1111X111	--	--	Bit 7 (MSB)	
Screen Reverse	11010000	Data	--	Whole screen reverse

Timing Characteristics

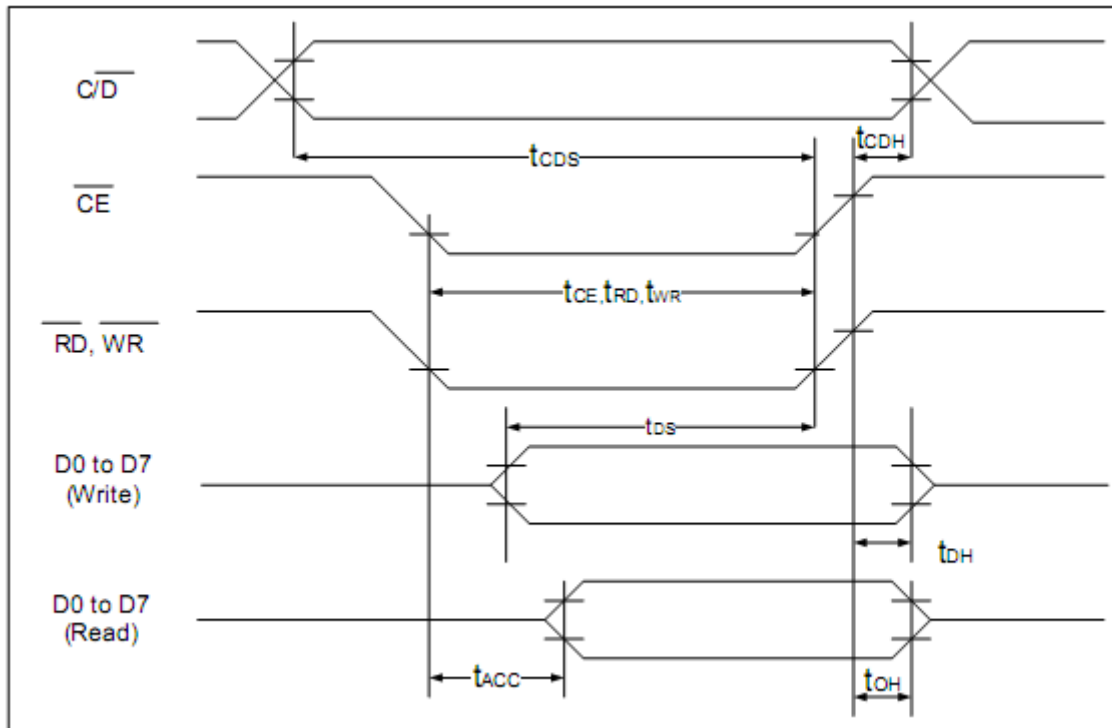

($V_{DD}=+5V\pm 5\%$, $GND=0V$, $T_a = -20$ to $+70^\circ C$)

Item	Symbol	Test Conditions	Min.	Max.	Unit
C/D Set Up Time	t_{CDS}	--	100	--	ns
C/D Hold Time	t_{CDH}	--	10	--	ns
CE, RD, WR Pulse Width	t_{CE}, t_{RD}, t_{WR}	--	80	--	ns
Data Set Up Time	t_{DS}	--	80	--	ns
Data Hold Time	t_{DH}	--	40	--	ns
Access Time	t_{ACC}	--	--	150	ns
Output Hold Time	t_{OH}	--	10	50	ns

Font Table

Upper 4 Lower 4 bit	LLLL	LLLH	LLHL	LLHH	LHLL	LHLH	LHHL	LHHH
LLLL		0	1	2	3	4	5	6
LLLH	!	7	8	9	a	b	c	d
LLHL	"	e	f	g	h	i	j	k
LLHH	#	l	m	n	o	p	q	r
LHLL	\$	s	t	u	v	w	x	y
LHLH	%	z	[\]	^	_	`
LHHL	&	{		}	~	?	@	A
LHHH	'	[]	^	_	`	a	b
HLLL	c	d	e	f	g	h	i	j
HLLH	k	l	m	n	o	p	q	r
HLHL	s	t	u	v	w	x	y	z
HLHH	[\]	^	_	`	a	b
HHLL	c	d	e	f	g	h	i	j
HHLH	k	l	m	n	o	p	q	r
HHHL	s	t	u	v	w	x	y	z
HHHH	[\]	^	_	`	a	b

Initialization Code

```
//-----  
Sub Writecom  
P1 = A           'move data to port 1  
Set P3.0         'set I/D for instruction  
Reset P3.1       'reset /CS  
Reset P3.4       'reset /WR  
Set P3.1         'set /CS  
Set P3.4         'set /WR  
End Sub  
  
Sub Writedata  
P1 = A           'move data to port 1  
Reset P3.0       'reset I/D for instruction  
Reset P3.1  
Reset P3.4       'toggle /CS and /WR  
Set P3.1  
Set P3.4  
End Sub  
  
//-----  
Sub Init  
Set P3.6  
Set P3.7  
Reset P3.3       'reset FS  
A = &H00  
Call Writedata  
Call Writedata  'text address = 0000h  
A = &H40  
Call Writecom   'text home address set  
A = &H00  
Call Writedata  
A = &H40       'graphic home address = 4000h  
Call Writedata  
A = &H42  
Call Writecom   'graphic home address set  
A = &H1E  
Call Writedata  
A = &H00       'text area address = 001Eh  
Call Writedata  
A = &H41  
Call Writecom   'text area control set  
A = &H1E  
Call Writedata  
A = &H00       'graphic area = 001Eh  
Call Writedata  
A = &H43  
Call Writecom   'graphic area control set  
A = &H80  
Call Writecom   'set display mode  
End Sub
```

Quality Information

Test Item	Content of Test	Test Condition	Note
High Temperature storage	Endurance test applying the high storage temperature for a long time.	+80°C , 200hrs	2
Low Temperature storage	Endurance test applying the low storage temperature for a long time.	-30°C , 200hrs	1,2
High Temperature Operation	Endurance test applying the electric stress (voltage & current) and the high thermal stress for a long time.	+70°C 200hrs	2
Low Temperature Operation	Endurance test applying the electric stress (voltage & current) and the low thermal stress for a long time.	-20°C , 200hrs	1,2
High Temperature / Humidity Operation	Endurance test applying the electric stress (voltage & current) and the high thermal with high humidity stress for a long time.	+60°C , 90% RH , 96hrs	1,2
Thermal Shock resistance	Endurance test applying the electric stress (voltage & current) during a cycle of low and high thermal stress.	-20°C,30min -> 25°C,5min -> 70°C,30min = 1 cycle 10 cycles	
Vibration test	Endurance test applying vibration to simulate transportation and use.	10-55Hz , 15mm amplitude. 60 sec in each of 3 directions X,Y,Z For 15 minutes	3
Static electricity test	Endurance test applying electric static discharge.	VS=800V, RS=1.5kΩ, CS=100pF One time	

Note 1: No condensation to be observed.

Note 2: Conducted after 4 hours of storage at 25°C, 0%RH.

Note 3: Test performed on product itself, not inside a container.

Precautions for using LCDs/LCMs

See Precautions at www.newhavendisplay.com/specs/precautions.pdf

Warranty Information and Terms & Conditions

http://www.newhavendisplay.com/index.php?main_page=terms



Компания «ЭлектроПласт» предлагает заключение долгосрочных отношений при поставках импортных электронных компонентов на взаимовыгодных условиях!

Наши преимущества:

- Оперативные поставки широкого спектра электронных компонентов отечественного и импортного производства напрямую от производителей и с крупнейших мировых складов;
- Поставка более 17-ти миллионов наименований электронных компонентов;
- Поставка сложных, дефицитных, либо снятых с производства позиций;
- Оперативные сроки поставки под заказ (от 5 рабочих дней);
- Экспресс доставка в любую точку России;
- Техническая поддержка проекта, помощь в подборе аналогов, поставка прототипов;
- Система менеджмента качества сертифицирована по Международному стандарту ISO 9001;
- Лицензия ФСБ на осуществление работ с использованием сведений, составляющих государственную тайну;
- Поставка специализированных компонентов (Xilinx, Altera, Analog Devices, Intersil, Interpoint, Microsemi, Aeroflex, Peregrine, Syfer, Eurofarad, Texas Instrument, Miteq, Cobham, E2V, MA-COM, Hittite, Mini-Circuits, General Dynamics и др.);

Помимо этого, одним из направлений компании «ЭлектроПласт» является направление «Источники питания». Мы предлагаем Вам помощь Конструкторского отдела:

- Подбор оптимального решения, техническое обоснование при выборе компонента;
- Подбор аналогов;
- Консультации по применению компонента;
- Поставка образцов и прототипов;
- Техническая поддержка проекта;
- Защита от снятия компонента с производства.



Как с нами связаться

Телефон: 8 (812) 309 58 32 (многоканальный)

Факс: 8 (812) 320-02-42

Электронная почта: org@eplast1.ru

Адрес: 198099, г. Санкт-Петербург, ул. Калинина, дом 2, корпус 4, литера А.