

rev	ecn no	dr	date
A	V06-0394	LP	2006/05/04
B	V07-0618	LP	2007/10/15
-	-	-	-

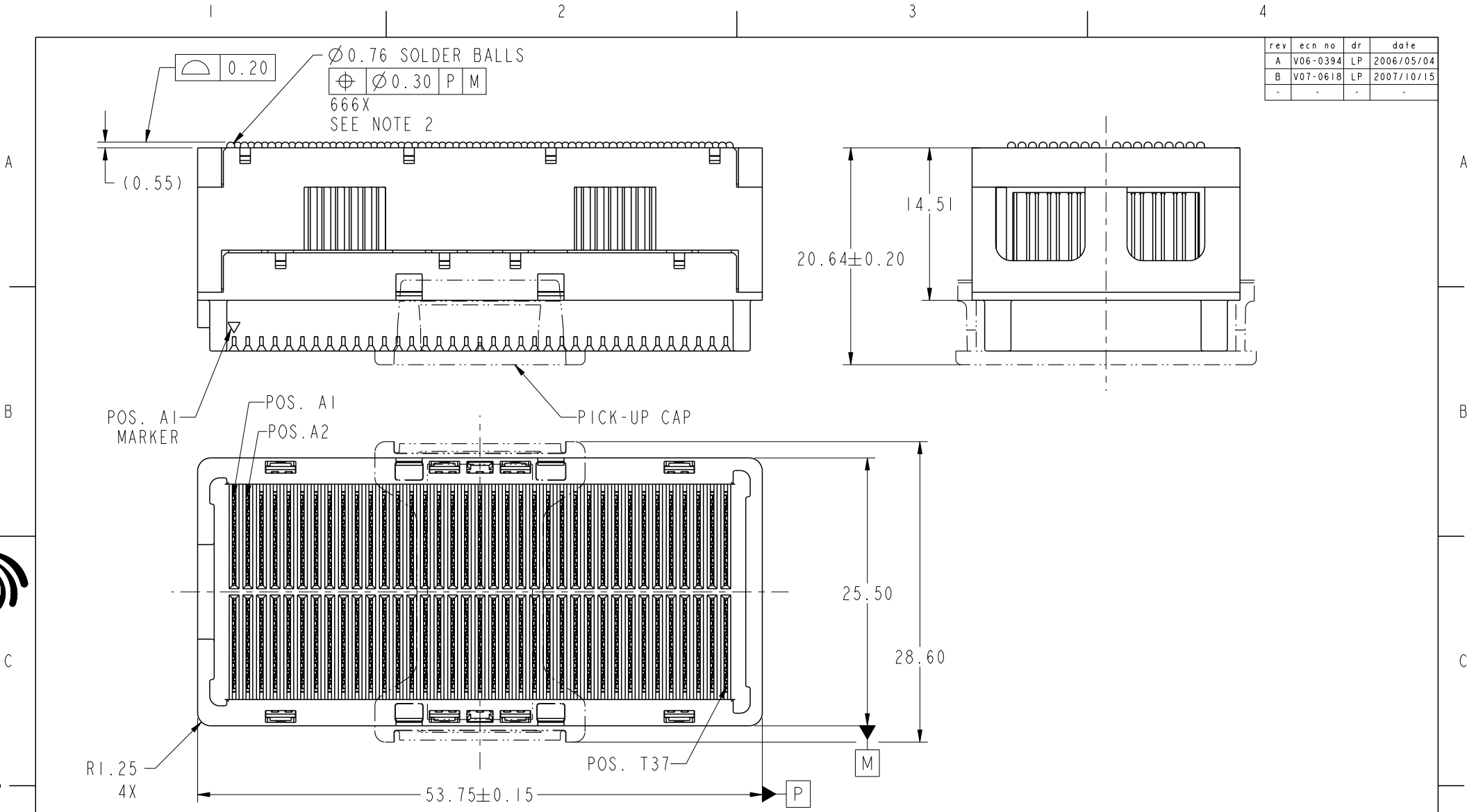

Copyright FCI.

spec ref	-			dr	Bill Lin	2010/02/02	projection 	mm 	size	A4	scale	1:1	
tolerance std	TOLERANCES UNLESS OTHERWISE SPECIFIED			eng	Nickor Zuo	2011/06/15			ecn no	ELX-DG-003943-1			
:	-			chr	Alex Cao	2011/06/24			product family	GIG-Array		rel level	Released
surface	3.2	linear	0.X ±0.30 0.XX ±0.10 0.XXX ±0.05	appr	Pei-Ming Zheng	2011/06/27			product family	GIG-Array		rel level	Released
ASME Y14.5		angular	0° ±2°	www.fci.com		cat. no.	-	product - Customer Drw	sheet 1 of 5				
title	GIG-Array - LOW INSERTION						dwg no	10060913		rev	C		
	15mm RECP. ASSY. 296 SIG. POS.												

PreE File - REV C - 2009-06-09



Copyright FCI.

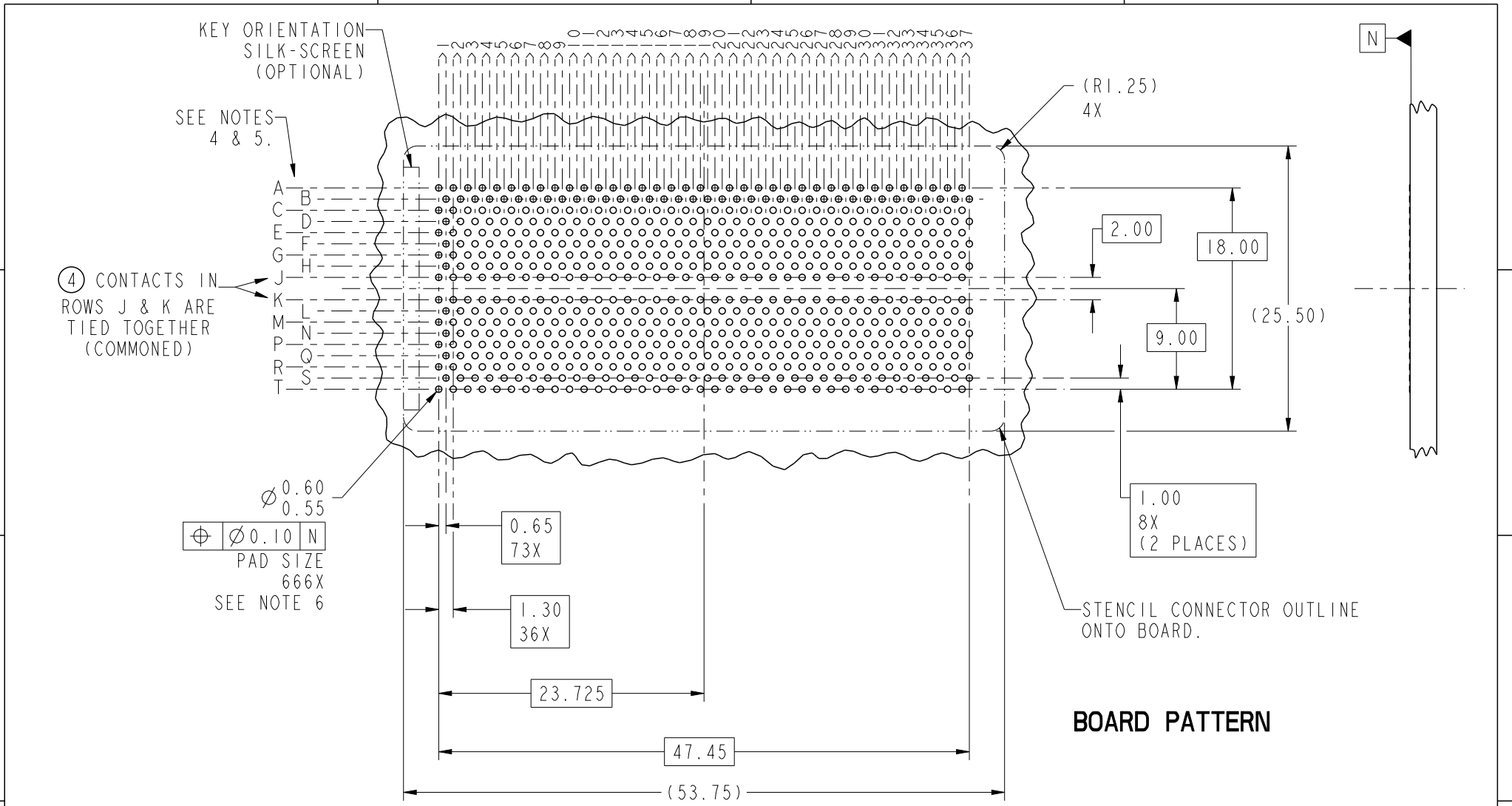

$\varnothing 0.60$
 $\varnothing 0.55$
 $\varnothing 0.10$ N
 PAD SIZE
 666X
 SEE NOTE 6

BOARD PATTERN

spec ref		-		dr	Bill Lin	2010/02/02	projection 	mm 	size	A4	scale	1:1
tolerance std		TOLERANCES UNLESS OTHERWISE SPECIFIED		eng	Nickor Zuo	2011/06/15			ecn no	ELX-DG-003943-1		
:		-		chr	Alex Cao	2011/06/24				rel level		Released
surface		linear	0.X	± 0.30	FCI	title	GIG-Array - LOW INSERTION	dwg no	10060913	rev	C	
ASME Y14.5			0.XX	± 0.10								www.fci.com
		0.XXX	± 0.05									
		angular	0°	$\pm 2^\circ$								

ProjE File - REV C - 2009-06-09

A

B

C

D

A

B

C

D

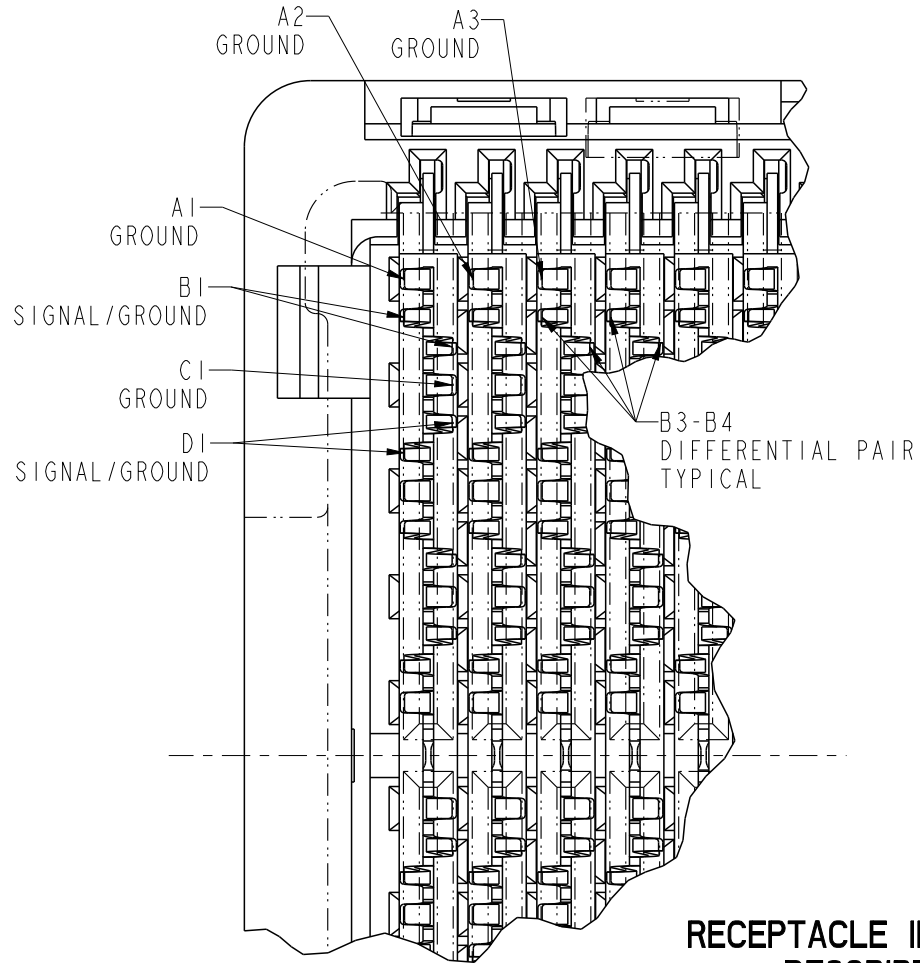

RECEPTACLE INTERFACE DESCRIPTION



Copyright FCI.

spec ref		-		dr	Bill Lin	2010/02/02	projection 	mm 	size	A4	scale	1:1
tolerance std	-	TOLERANCES UNLESS OTHERWISE SPECIFIED		eng	Nickor Zuo	2011/06/15			ecn no	ELX-DG-003943-1		
				chr	Alex Cao	2011/06/24				rel level	Released	
ASME Y14.5		angular	0°	±2°	appr	Pei-Ming Zheng	2011/06/27	product family		GIG-Array		
surface	3.2	linear	0.X	±0.30	 www.fci.com	title		GIG-Array - LOW INSERTION		dwg no 10060913	rev	C
			0.XX	±0.10		15mm RECP. ASSY. 296 SIG. POS.		Product - Customer Drw			sheet 3 of 5	
			0.XXX	±0.05		cat. no.	-					

**FLAT AREA
FOR PICK-UP CAP**
SCALE 2:1

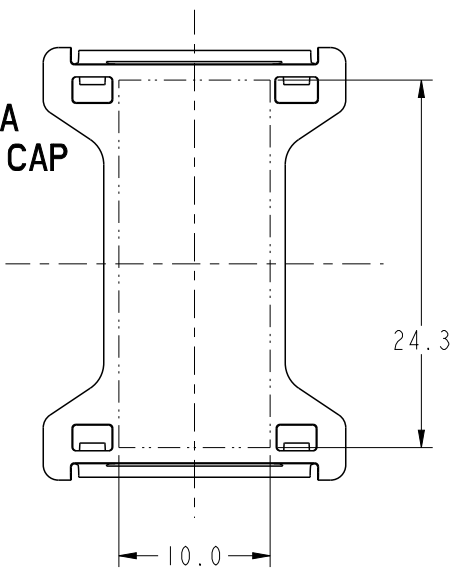

DIM "A" REF.
MATED HEIGHT
AFTER REFLOW
SEE NOTE 3.

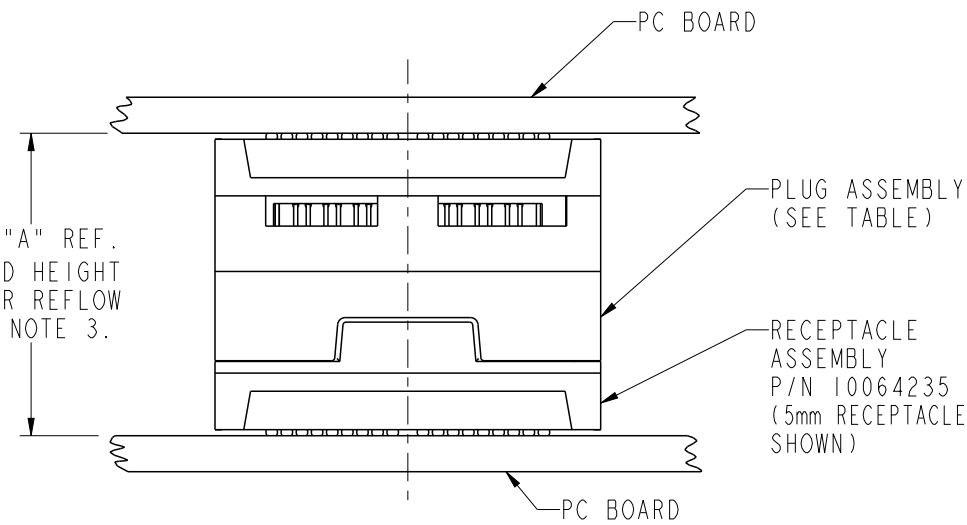

END VIEW OF MATED CONNECTORS
SCALE 2:1

DIM. "A"	PLUG ASSEMBLY P/N
25	55720
27	10026804
28	10055143
30	55700
35	55727
40	10054784



Copyright FCI.

spec ref -		dr Bill Lin 2010/02/02		projection 	mm 	size A4	scale 1:1	
tolerance std		eng Nickor Zuo 2011/06/15				ecn no ELX-DG-003943-1		
:		chr Alex Cao 2011/06/24				rel level Released		
-		appr Pei-Ming Zheng 2011/06/27		product family GIG-Array		rev		
surface $\sqrt{3.2}$ ASME Y14.5	linear	0.X	± 0.30	 www.fci.com	title GIG-Array - LOW INSERTION 15mm RECP. ASSY. 296 SIG. POS.	dwg no 10060913	rev C	
		0.XX	± 0.10					
		0.XXX	± 0.05					
	angular	0°	$\pm 2^\circ$	cat. no. -	Product - Customer Drw	sheet 4 of 5		

Pro/E File - REV C - 2009-06-09

PRODUCT NUMBER	SOLDER BALL COMPOSITION	CONTACT PLATING PERFORMANCE LEVEL
10060913-001	STANDARD (EUTECTIC)	PERFORMANCE-BASED PLATING, QUALIFIED TO MEET THE REQUIREMENTS OF FCI PRODUCT SPECIFICATION GS-12-192, INCLUDING TELCORDIA CENTRAL OFFICE
10060913-001LF	LEADFREE	
10060913-201	STANDARD (EUTECTIC)	
10060913-201LF	LEADFREE	

Au over Ni

NOTES:

- ① MATERIAL:
HOUSING: LCP
CONTACT: COPPER ALLOY
PLATING (CONTACT): Au OVER Ni.
UL RATING: 94 V-0
SOLDBALL: (SEE TABLE) EUTECTIC SnPb OR LEAD FREE 95.5 Sn/4Ag/0.5Cu.
- ② SOLDER BALLS WILL NOT BE PERFECT SPHERICAL SHAPE DUE TO REFLOW ATTACHMENT.
- ③ MATED HEIGHT EFFECTED BY CUSTOMERS' PCB PAD SIZE, PLATING, SOLDER REFLOW PROFILE & SOLDER PASTE.
- ④ CONTACTS IN ROWS A,C,E,G,J,K,M,P,R AND T ARE SINGLE BEAM CONTACTS USED AS GROUND PINS.
(NOTE: CONTACTS IN ROWS J & K ARE TIED TOGETHER [COMMONED])
- ⑤ CONTACTS IN ROWS B,D,F,H,L,N,Q AND S ARE DUAL BEAM CONTACTS, TYPICALLY USED AS SIGNAL PINS.
- ⑥ SPECIFIED POSITIONAL TOLERANCE DEFINES PAD TO PAD LOCATION WITHIN LAND PATTERN. POSITIONAL TOLERANCE OF LAND PATTERN TO FUDICIAL MARKS OR PCB DATUMS SHALL BE DEFINED BY CUSTOMER. FOR RECOMMENDED PRODUCT APPLICATION AND PCB DESIGN DETAILS, SEE DOC. NO. GS-20-016.
- ⑦ FOR PROPER APPLICATION FOLLOW FCI APPLICATION SPECIFICATION GS-20-033. LEAD FREE SOLDER BALLS WILL NOT SOLDER PROPERLY IN A LEADED SOLDER PROCESS DUE TO A HIGHER REFLOW TEMPERATURE. LEADFREE PRODUCT IS THEREFORE NOT BACKWARDS COMPATIBLE WITH LEADED OR SOME SOLDERING APPLICATIONS. REFERENCE FCI APPLICATION SPECIFICATION.
- ⑧ THIS PRODUCT MEETS THE EUROPEAN UNION DIRECTIVES AND OTHER COUNTRY REGULATIONS AS DESCRIBED IN GS-22-008. PRODUCT MEETING THIS DIRECTIVE IS IDENTIFIED IN THE CODE NUMBER MARKED ON EACH PART BY HAVING AN "X" IN THE SEVENTH CHARACTER POSITION.

spec ref	-	dr	Bill Lin	2010/02/02	projection		size	A4	scale	1:1		
tolerance std	TOLERANCES UNLESS OTHERWISE SPECIFIED	eng	Nickor Zuo	2011/06/15			ecn no	ELX-DG-003943-1				
:		chr	Alex Cao	2011/06/24			product family	GIG-Array	rel level	Released		
-		appr	Pei-Ming Zheng	2011/06/27		title	GIG-Array - LOW INSERTION		dwg no	10060913		
surface		linear	0.X	±0.30		15mm RECP. ASSY. 296 SIG. POS.		www.fci.com cat. no. - Product - Customer Drw sheet 5 of 5				
ASME Y14.5		angular	0°	±2°								



Компания «ЭлектроПласт» предлагает заключение долгосрочных отношений при поставках импортных электронных компонентов на взаимовыгодных условиях!

Наши преимущества:

- Оперативные поставки широкого спектра электронных компонентов отечественного и импортного производства напрямую от производителей и с крупнейших мировых складов;
- Поставка более 17-ти миллионов наименований электронных компонентов;
- Поставка сложных, дефицитных, либо снятых с производства позиций;
- Оперативные сроки поставки под заказ (от 5 рабочих дней);
- Экспресс доставка в любую точку России;
- Техническая поддержка проекта, помощь в подборе аналогов, поставка прототипов;
- Система менеджмента качества сертифицирована по Международному стандарту ISO 9001;
- Лицензия ФСБ на осуществление работ с использованием сведений, составляющих государственную тайну;
- Поставка специализированных компонентов (Xilinx, Altera, Analog Devices, Intersil, Interpoint, Microsemi, Aeroflex, Peregrine, Syfer, Eurofarad, Texas Instrument, Miteq, Cobham, E2V, MA-COM, Hittite, Mini-Circuits, General Dynamics и др.);

Помимо этого, одним из направлений компании «ЭлектроПласт» является направление «Источники питания». Мы предлагаем Вам помощь Конструкторского отдела:

- Подбор оптимального решения, техническое обоснование при выборе компонента;
- Подбор аналогов;
- Консультации по применению компонента;
- Поставка образцов и прототипов;
- Техническая поддержка проекта;
- Защита от снятия компонента с производства.



Как с нами связаться

Телефон: 8 (812) 309 58 32 (многоканальный)

Факс: 8 (812) 320-02-42

Электронная почта: org@eplast1.ru

Адрес: 198099, г. Санкт-Петербург, ул. Калинина, дом 2, корпус 4, литера А.