

# NCP4305

## Secondary Side Synchronous Rectification Driver for High Efficiency SMPS Topologies

The NCP4305 is high performance driver tailored to control a synchronous rectification MOSFET in switch mode power supplies. Thanks to its high performance drivers and versatility, it can be used in various topologies such as DCM or CCM flyback, quasi resonant flyback, forward and half bridge resonant LLC.

The combination of externally adjustable minimum off-time and on-time blanking periods helps to fight the ringing induced by the PCB layout and other parasitic elements. A reliable and noise less operation of the SR system is insured due to the Self Synchronization feature. The NCP4305 also utilizes Kelvin connection of the driver to the MOSFET to achieve high efficiency operation at full load and utilizes a light load detection architecture to achieve high efficiency at light load.

The precise turn-off threshold, extremely low turn-off delay time and high sink current capability of the driver allow the maximum synchronous rectification MOSFET conduction time and enables maximum SMPS efficiency. The high accuracy driver and 5 V gate clamp enables the use of GaN FETs.

### Features

- Self-Contained Control of Synchronous Rectifier in CCM, DCM and QR for Flyback, Forward or LLC Applications
- Precise True Secondary Zero Current Detection
- Typically 12 ns Turn off Delay from Current Sense Input to Driver
- Rugged Current Sense Pin (up to 200 V)
- Ultrafast Turn-off Trigger Interface/Disable Input (7.5 ns)
- Adjustable Minimum ON-Time
- Adjustable Minimum OFF-Time with Ringing Detection
- Adjustable Maximum ON-Time for CCM Controlling of Primary QR Controller
- Improved Robust Self Synchronization Capability
- 8 A / 4 A Peak Current Sink / Source Drive Capability
- Operating Voltage Range up to  $V_{CC} = 35$  V
- Automatic Light-load & Disable Mode
- Adaptive Gate Drive Clamp
- GaN Transistor Driving Capability (options A and C)
- Low Startup and Disable Current Consumption
- Maximum Operation Frequency up to 1 MHz
- SOIC-8 and DFN-8 (4x4) and WDFN8 (2x2) Packages
- These are Pb-Free Devices



ON Semiconductor®

[www.onsemi.com](http://www.onsemi.com)

### MARKING DIAGRAMS

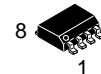

SOIC-8  
D SUFFIX  
CASE 751

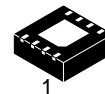
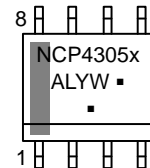

DFN8  
MN SUFFIX  
CASE 488AF

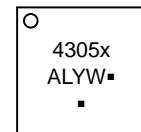

WDFN8  
MT SUFFIX  
CASE 511AT

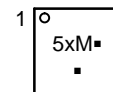

4305x = Specific Device Code  
x = A, B, C, D or Q  
A = Assembly Location  
L = Wafer Lot  
Y = Year  
W = Work Week  
M = Date Code  
▪ = Pb-Free Package

(Note: Microdot may be in either location)

### ORDERING INFORMATION

See detailed ordering and shipping information on page 49 of this data sheet.

### Typical Applications

- Notebook Adapters
- High Power Density AC/DC Power Supplies (Cell Phone Chargers)
- LCD TVs
- All SMPS with High Efficiency Requirements

# NCP4305

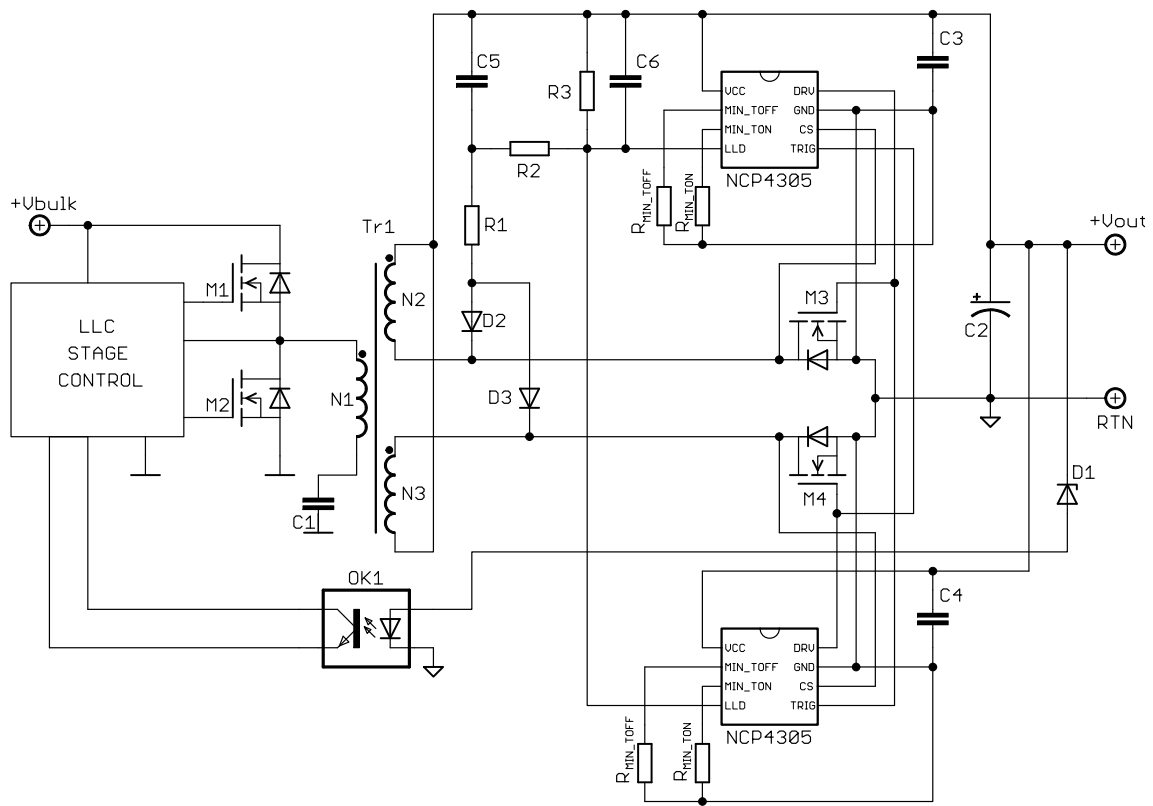

Figure 1. Typical Application Example – LLC Converter with Optional LLD and Trigger Utilization

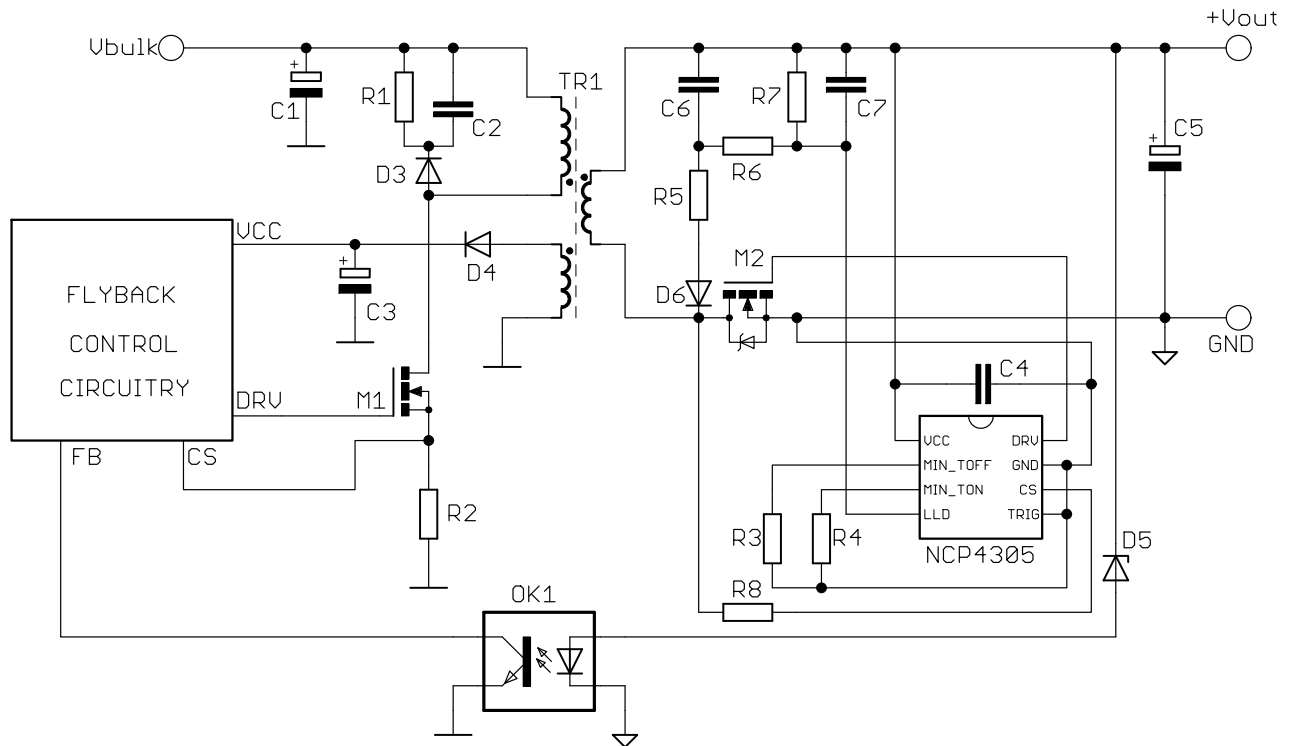

Figure 2. Typical Application Example – DCM, CCM or QR Flyback Converter with optional LLD and Disabled TRIG

# NCP4305

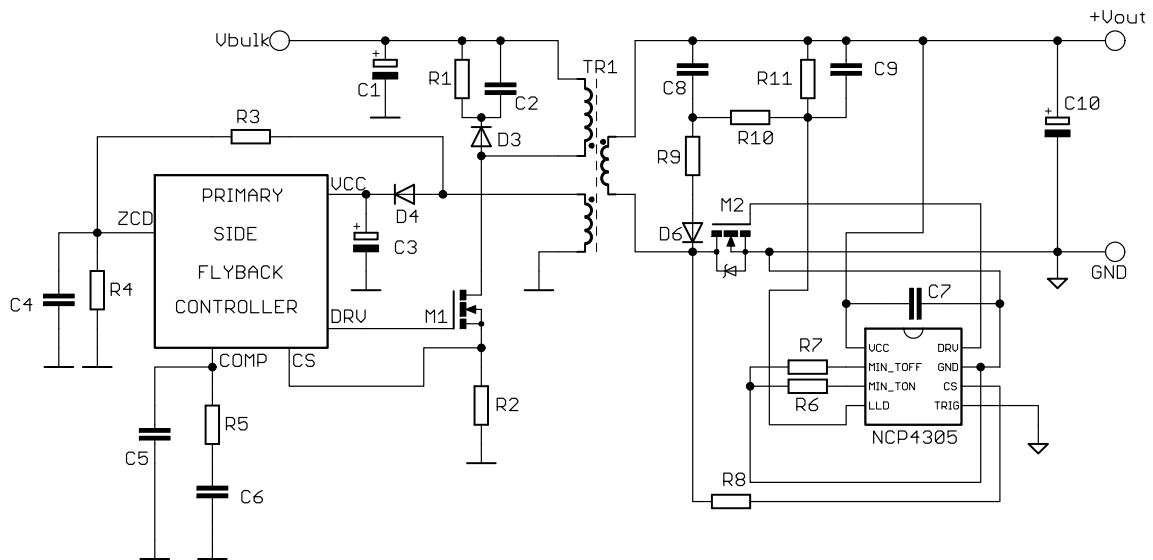

Figure 3. Typical Application Example – Primary Side Flyback Converter with optional LLD and Disabled TRIG

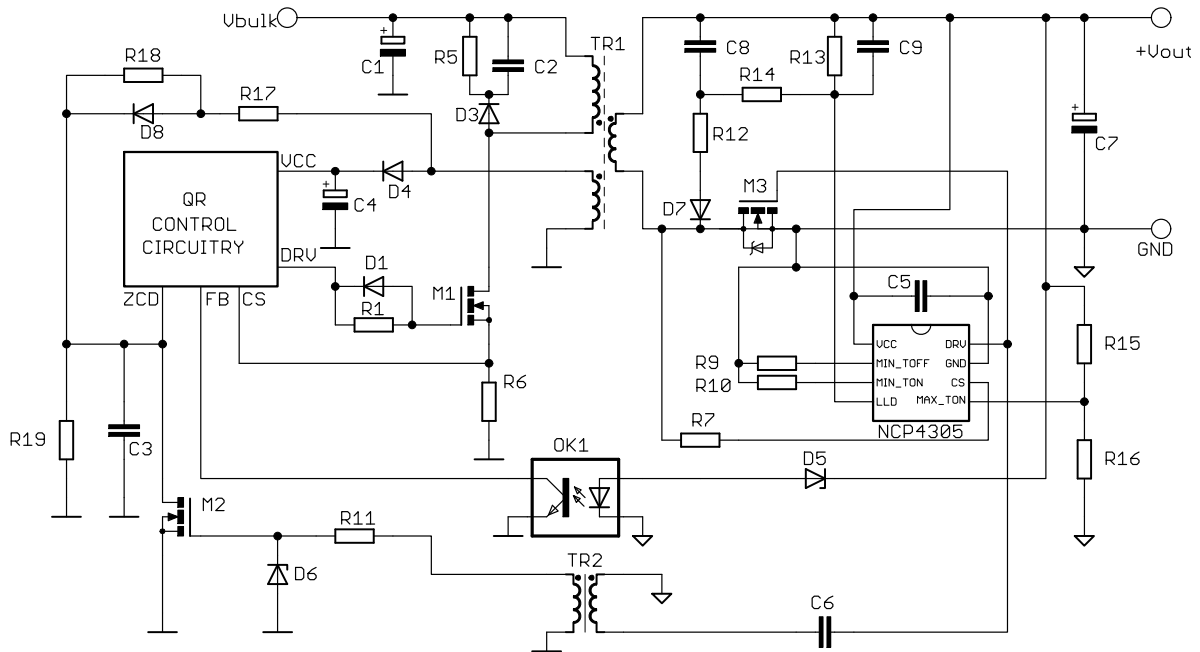

Figure 4. Typical Application Example – QR Converter – Capability to Force Primary into CCM Under Heavy Loads utilizing MAX-TON

# NCP4305

## PIN FUNCTION DESCRIPTION

ver. A, B, C, D	ver. Q	Pin Name	Description
1	1	VCC	Supply voltage pin
2	2	MIN_TOFF	Adjust the minimum off time period by connecting resistor to ground.
3	3	MIN_TON	Adjust the minimum on time period by connecting resistor to ground.
4	4	LLD	This input modulates the driver clamp level and/or turns the driver off during light load conditions.
5	-	TRIG/DIS	Ultrafast turn-off input that can be used to turn off the SR MOSFET in CCM applications in order to improve efficiency. Activates disable mode if pulled-up for more than 100 $\mu$ s.
6	6	CS	Current sense pin detects if the current flows through the SR MOSFET and/or its body diode. Basic turn-off detection threshold is 0 mV. A resistor in series with this pin can decrease the turn off threshold if needed.
7	7	GND	Ground connection for the SR MOSFET driver and V <sub>CC</sub> decoupling capacitor. Ground connection for minimum on and off time adjust resistors, LLD and trigger inputs. GND pin should be wired directly to the SR MOSFET source terminal/soldering point using Kelvin connection. DFN8 exposed flag should be connected to GND
8	8	DRV	Driver output for the SR MOSFET
-	5	MAX_TON	Adjust the maximum on time period by connecting resistor to ground.

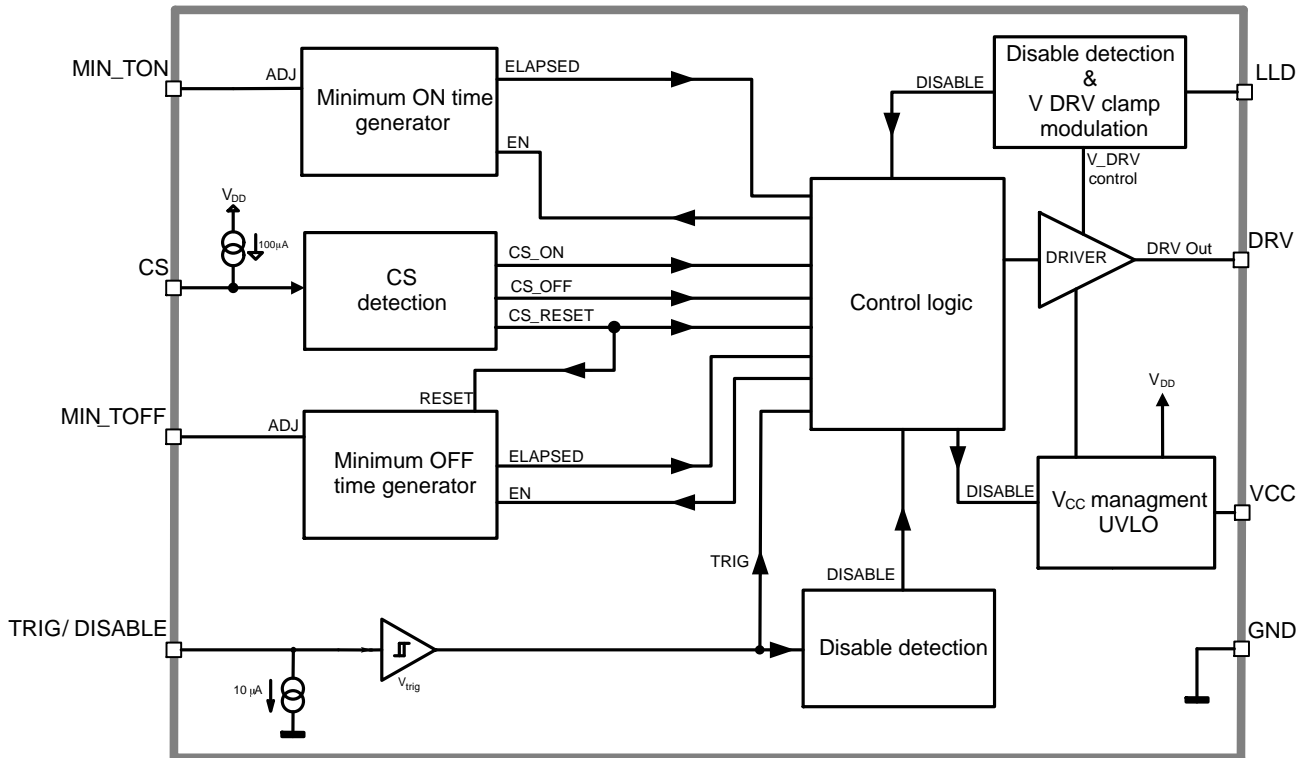

Figure 5. Internal Circuit Architecture – NCP4305A, B, C, D

# NCP4305

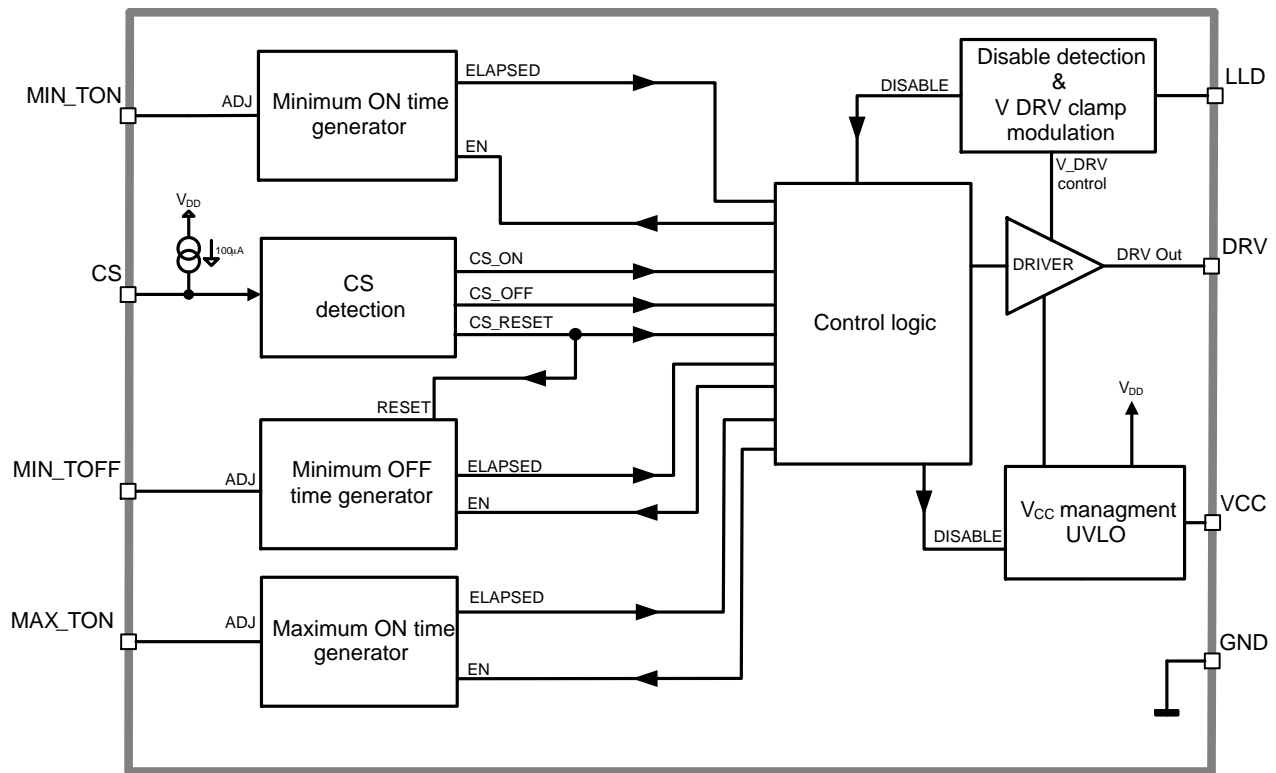

Figure 6. Internal Circuit Architecture – NCP4305Q (CCM QR) with MAX\_TON

## ABSOLUTE MAXIMUM RATINGS

Rating	Symbol	Value	Unit
Supply Voltage	$V_{CC}$	-0.3 to 37.0	V
TRIG/DIS, MIN_TON, MIN_TOFF, MAX_TON, LLD Input Voltage	$V_{TRIG/DIS}$ , $V_{MIN\_TON}$ , $V_{MIN\_TOFF}$ , $V_{MAX\_TON}$ , $V_{LLD}$	-0.3 to $V_{CC}$	V
Driver Output Voltage	$V_{DRV}$	-0.3 to 17.0	V
Current Sense Input Voltage	$V_{CS}$	-4 to 200	V
Current Sense Dynamic Input Voltage ( $t_{PW} = 200$ ns)	$V_{CS\_DYN}$	-10 to 200	V
MIN_TON, MIN_TOFF, MAX_TON, LLD, TRIG Input Current	$I_{MIN\_TON}$ , $I_{MIN\_TOFF}$ , $I_{MAX\_TON}$ , $I_{LLD}$ , $I_{TRIG}$	-10 to 10	mA
Junction to Air Thermal Resistance, 1 oz 1 in <sup>2</sup> Copper Area, SOIC8	$R_{\theta J-A\_SOIC8}$	160	°C/W
Junction to Air Thermal Resistance, 1 oz 1 in <sup>2</sup> Copper Area, DFN8	$R_{\theta J-A\_DFN8}$	80	°C/W
Junction to Air Thermal Resistance, 1 oz 1 in <sup>2</sup> Copper Area, WDFN8	$R_{\theta J-A\_WDFN8}$	160	°C/W
Maximum Junction Temperature	$T_{JMAX}$	150	°C
Storage Temperature	$T_{STG}$	-60 to 150	°C
ESD Capability, Human Body Model, Except Pin 6, per JESD22-A114E	$ESD_{HBM}$	2000	V
ESD Capability, Human Body Model, Pin 6, per JESD22-A114E	$ESD_{HBM}$	1000	V
ESD Capability, Machine Model, per JESD22-A115-A	$ESD_{MM}$	200	V
ESD Capability, Charged Device Model, Except Pin 6, per JESD22-C101F	$ESD_{CDM}$	750	V
ESD Capability, Charged Device Model, Pin 6, per JESD22-C101F	$ESD_{CDM}$	250	V

Stresses exceeding those listed in the Maximum Ratings table may damage the device. If any of these limits are exceeded, device functionality should not be assumed, damage may occur and reliability may be affected.

1. This device meets latch-up tests defined by JEDEC Standard JESD78D Class I.

# NCP4305

## RECOMMENDED OPERATING CONDITIONS

Parameter	Symbol	Min	Max	Unit
Maximum Operating Input Voltage	$V_{CC}$		35	V
Operating Junction Temperature	$T_J$	-40	125	°C

Functional operation above the stresses listed in the Recommended Operating Ranges is not implied. Extended exposure to stresses beyond the Recommended Operating Ranges limits may affect device reliability.

## ELECTRICAL CHARACTERISTICS

-40°C ≤  $T_J$  ≤ 125°C;  $V_{CC} = 12$  V;  $C_{DRV} = 0$  nF;  $R_{MIN\_TON} = R_{MIN\_TOFF} = 10$  kΩ;  $V_{TRIG/DIS} = 0$  V;  $V_{LLD} = 0$  V;  $V_{CS} = -1$  to +4 V;  $f_{CS} = 100$  kHz,  $DC_{CS} = 50\%$ , unless otherwise noted. Typical values are at  $T_J = +25$ °C

Parameter	Test Conditions	Symbol	Min	Typ	Max	Unit
-----------	-----------------	--------	-----	-----	-----	------

### SUPPLY SECTION

VCC UVLO (ver. B & C)	$V_{CC}$ rising	$V_{CCON}$	8.3	8.8	9.4	V	
	$V_{CC}$ falling	$V_{CCOFF}$	7.3	7.8	8.3		
VCC UVLO Hysteresis (ver. B & C)		$V_{CCHYS}$		1.0		V	
VCC UVLO (ver. A, D & Q)	$V_{CC}$ rising	$V_{CCON}$	4.20	4.45	4.80	V	
	$V_{CC}$ falling	$V_{CCOFF}$	3.70	3.95	4.20		
VCC UVLO Hysteresis (ver. A, D & Q)		$V_{CCHYS}$		0.5		V	
Start-up Delay	$V_{CC}$ rising from 0 to $V_{CCON} + 1$ V @ $tr = 10$ μs	$t_{START\_DEL}$		75	125	μs	
Current Consumption, $R_{MIN\_TON} = R_{MIN\_TOFF} = 0$ kΩ	$C_{LOAD} = 0$ nF, $f_{SW} = 500$ kHz	A, C	$I_{CC}$	3.3	4.0	5.6	mA
		B, D, Q		3.8	4.5	6.0	
	$C_{LOAD} = 0$ nF, $f_{SW} = 500$ kHz, WDFN	A, C		3.0	4.0	5.6	
		B, D, Q		3.5	4.5	6.0	
	$C_{LOAD} = 1$ nF, $f_{SW} = 500$ kHz	A, C		4.5	6.0	7.5	
		B, D, Q		7.7	9.0	10.7	
$C_{LOAD} = 10$ nF, $f_{SW} = 500$ kHz	A, C	20	25	30			
	B, D, Q	40	50	60			
Current Consumption	No switching, $V_{CS} = 0$ V, $R_{MIN\_TON} = R_{MIN\_TOFF} = 0$ k	$I_{CC}$	1.5	2.0	2.5	mA	
Current Consumption below UVLO	No switching, $V_{CC} = V_{CCOFF} - 0.1$ V, $V_{CS} = 0$ V	$I_{CC\_UVLO}$		75	125	μA	
Current Consumption in Disable Mode	$V_{LLD} = V_{CC} - 0.1$ V, $V_{CS} = 0$ V	$I_{CC\_DIS}$	40	55	70	μA	
	$V_{TRIG} = 5$ V, $V_{LLD} = V_{CC} - 3$ V, $V_{CS} = 0$ V		45	65	80		

### DRIVER OUTPUT

Output Voltage Rise-Time	$C_{LOAD} = 10$ nF, 10% to 90% $V_{DRVMAX}$	$t_r$		40	55	ns
Output Voltage Fall-Time	$C_{LOAD} = 10$ nF, 90% to 10% $V_{DRVMAX}$	$t_f$		20	35	ns
Driver Source Resistance		$R_{DRV\_SOURCE}$		1.2		Ω
Driver Sink Resistance		$R_{DRV\_SINK}$		0.5		Ω
Output Peak Source Current		$I_{DRV\_SOURCE}$		4		A
Output Peak Sink Current		$I_{DRV\_SINK}$		8		A
Maximum Driver Output Voltage	$V_{CC} = 35$ V, $C_{LOAD} > 1$ nF, $V_{LLD} = 0$ V, (ver. B, D and Q)	$V_{DRVMAX}$	9.0	9.5	10.5	V
	$V_{CC} = 35$ V, $C_{LOAD} > 1$ nF, $V_{LLD} = 0$ V, (ver. A, C)		4.3	4.7	5.5	
Minimum Driver Output Voltage	$V_{CC} = V_{CCOFF} + 200$ mV, $V_{LLD} = 0$ V, (ver. B)	$V_{DRVMIN}$	7.2	7.8	8.5	V
	$V_{CC} = V_{CCOFF} + 200$ mV, $V_{LLD} = 0$ V, (ver. C)		4.2	4.7	5.3	
	$V_{CC} = V_{CCOFF} + 200$ mV, $V_{LLD} = 0$ V, (ver. A, D, Q)		3.6	4.0	4.4	
Minimum Driver Output Voltage	$V_{LLD} = V_{CC} - V_{LLDREC}$ V	$V_{DRVLLDMIN}$	0.0	0.4	1.2	V

# NCP4305

## ELECTRICAL CHARACTERISTICS

$-40^{\circ}\text{C} \leq T_J \leq 125^{\circ}\text{C}$ ;  $V_{CC} = 12\text{ V}$ ;  $C_{DRV} = 0\text{ nF}$ ;  $R_{MIN\_TON} = R_{MIN\_TOFF} = 10\text{ k}\Omega$ ;  $V_{TRIG/DIS} = 0\text{ V}$ ;  $V_{LLD} = 0\text{ V}$ ;  $V_{CS} = -1\text{ to }+4\text{ V}$ ;  $f_{CS} = 100\text{ kHz}$ ,  $DC_{CS} = 50\%$ , unless otherwise noted. Typical values are at  $T_J = +25^{\circ}\text{C}$

Parameter	Test Conditions	Symbol	Min	Typ	Max	Unit
-----------	-----------------	--------	-----	-----	-----	------

### CS INPUT

Total Propagation Delay From CS to DRV Output On	$V_{CS}$ goes down from 4 to $-1\text{ V}$ , $t_{r\_CS} = 5\text{ ns}$	$t_{PD\_ON}$		35	60	ns
Total Propagation Delay From CS to DRV Output Off	$V_{CS}$ goes up from $-1$ to $4\text{ V}$ , $t_{r\_CS} = 5\text{ ns}$	$t_{PD\_OFF}$		12	23	ns
CS Bias Current	$V_{CS} = -20\text{ mV}$	$I_{CS}$	-105	-100	-95	$\mu\text{A}$
Turn On CS Threshold Voltage		$V_{TH\_CS\_ON}$	-120	-75	-40	mV
Turn Off CS Threshold Voltage	Guaranteed by Design	$V_{TH\_CS\_OFF}$	-1		0	mV
Turn Off Timer Reset Threshold Voltage		$V_{TH\_CS\_RESET}$	0.42	0.48	0.54	V
CS Leakage Current	$V_{CS} = 200\text{ V}$	$I_{CS\_LEAKAGE}$			0.4	$\mu\text{A}$

### TRIGGER DISABLE INPUT

Minimum Trigger Pulse Duration	$V_{TRIG} = 5\text{ V}$ ; Shorter pulses may not be proceeded	$t_{TRIG\_PW\_MIN}$			10	ns
Trigger Threshold Voltage		$V_{TRIG\_TH}$	1.87	2.02	2.18	V
Trigger to DRV Propagation Delay	$V_{TRIG}$ goes from 0 to $5\text{ V}$ , $t_{r\_TRIG} = 5\text{ ns}$	$t_{PD\_TRIG}$		7.5	12.5	ns
Trigger Blank Time After DRV Turn-on Event	$V_{CS}$ drops below $V_{TH\_CS\_ON}$	$t_{TRIG\_BLANK}$	35	50	65	ns
Delay to Disable Mode	$V_{TRIG} = 5\text{ V}$	$t_{DIS\_TIM}$	75	100	125	$\mu\text{s}$
Disable Recovery Timer	$V_{TRIG}$ goes down from 5 to $0\text{ V}$	$t_{DIS\_REC}$	5	8	13	$\mu\text{s}$
Minimum Pulse Duration to Disable Mode End	$V_{TRIG} = 0\text{ V}$ ; Shorter pulses may not be proceeded	$t_{DIS\_END\_MIN}$			200	ns
Pull Down Current	$V_{TRIG} = 5\text{ V}$	$I_{TRIG}$	9	13	16	$\mu\text{A}$

### MINIMUM $t_{ON}$ and $t_{OFF}$ ADJUST

Minimum $t_{ON}$ time	$R_{MIN\_TON} = 0\ \Omega$	$t_{ON\_MIN}$	35	55	75	ns
Minimum $t_{OFF}$ time	$R_{MIN\_TOFF} = 0\ \Omega$	$t_{OFF\_MIN}$	190	245	290	ns
Minimum $t_{ON}$ time	$R_{MIN\_TON} = 10\text{ k}\Omega$	$t_{ON\_MIN}$	0.92	1.00	1.08	$\mu\text{s}$
Minimum $t_{OFF}$ time	$R_{MIN\_TOFF} = 10\text{ k}\Omega$	$t_{OFF\_MIN}$	0.92	1.00	1.08	$\mu\text{s}$
Minimum $t_{ON}$ time	$R_{MIN\_TON} = 50\text{ k}\Omega$	$t_{ON\_MIN}$	4.62	5.00	5.38	$\mu\text{s}$
Minimum $t_{OFF}$ time	$R_{MIN\_TOFF} = 50\text{ k}\Omega$	$t_{OFF\_MIN}$	4.62	5.00	5.38	$\mu\text{s}$

### MAXIMUM $t_{ON}$ ADJUST

Maximum $t_{ON}$ Time	$V_{MAX\_TON} = 3\text{ V}$	$t_{ON\_MAX}$	4.3	4.8	5.3	$\mu\text{s}$
Maximum $t_{ON}$ Time	$V_{MAX\_TON} = 0.3\text{ V}$	$t_{ON\_MAX}$	41	48	55	$\mu\text{s}$
Maximum $t_{ON}$ Output Current	$V_{MAX\_TON} = 0.3\text{ V}$	$I_{MAX\_TON}$	-105	-100	-95	$\mu\text{A}$

### LLD INPUT

Disable Threshold	$V_{LLD\_DIS} = V_{CC} - V_{LLD}$	$V_{LLD\_DIS}$	0.8	0.9	1.0	V
Recovery Threshold	$V_{LLD\_REC} = V_{CC} - V_{LLD}$	$V_{LLD\_REC}$	0.9	1.0	1.1	V
Disable Hysteresis		$V_{LLD\_DISH}$		0.1		V
Disable Time Hysteresis	Disable to Normal, Normal to Disable	$t_{LLD\_DISH}$		45		$\mu\text{s}$
Disable Recovery Time		$t_{LLD\_DIS\_REC}$	7.0	12.5	16.0	$\mu\text{s}$
Low Pass Filter Frequency		$f_{LPLL}$	6	10	13	kHz
Driver Voltage Clamp Threshold	$V_{DRV} = V_{DRVMAX}$ , $V_{LLDMAX} = V_{CC} - V_{LLD}$	$V_{LLDMAX}$		2.0		V

Product parametric performance is indicated in the Electrical Characteristics for the listed test conditions, unless otherwise noted. Product performance may not be indicated by the Electrical Characteristics if operated under different conditions.

# NCP4305

## TYPICAL CHARACTERISTICS

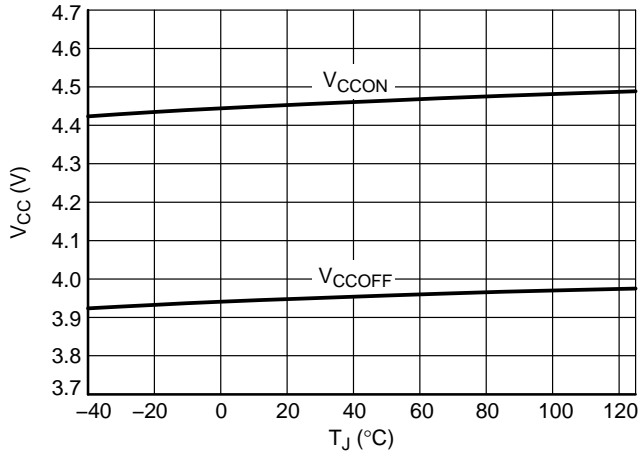

Figure 7. V<sub>CCON</sub> and V<sub>CCOFF</sub> Levels,  
ver. A, D, Q

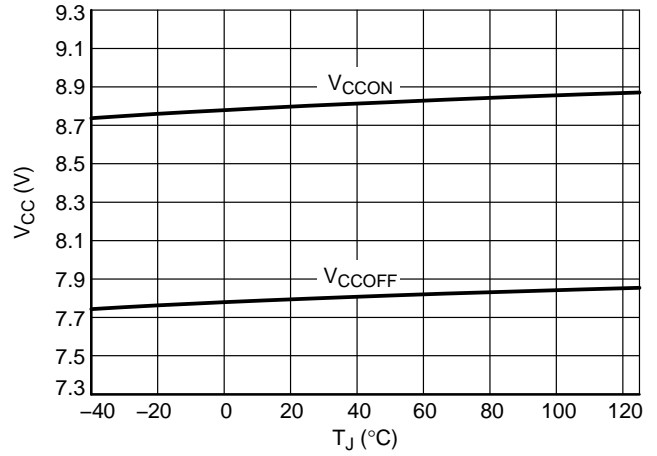

Figure 8. V<sub>CCON</sub> and V<sub>CCOFF</sub> Levels,  
ver. B, C



TYPICAL CHARACTERISTICS

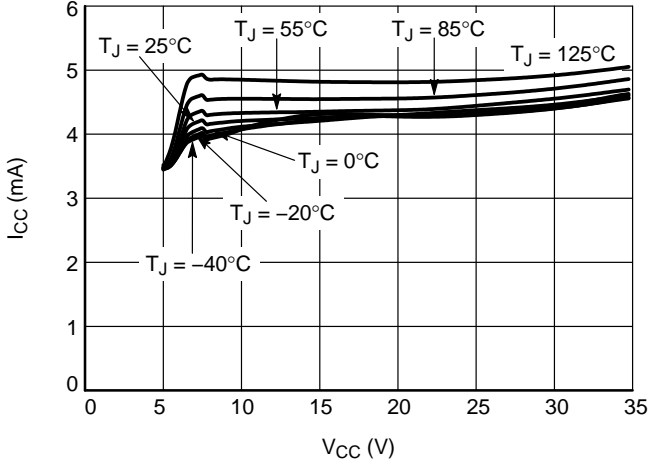

Figure 9. Current Consumption,  $C_{DRV} = 0$  nF,  $f_{CS} = 500$  kHz, ver. D

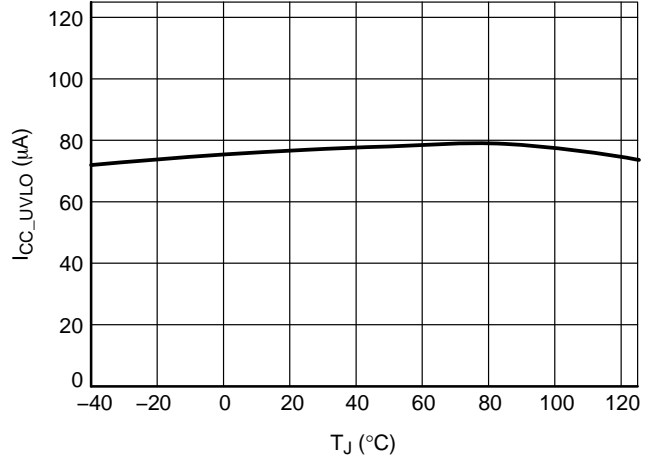

Figure 10. Current Consumption,  $V_{CC} = V_{CCOFF} - 0.1$  V,  $V_{CS} = 0$  V, ver. D

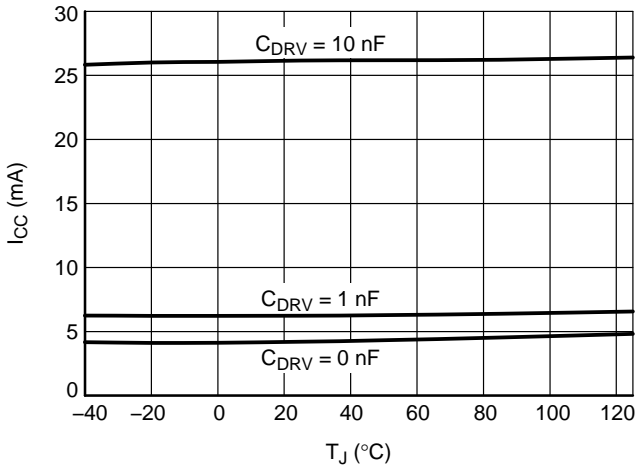

Figure 11. Current Consumption,  $V_{CC} = 12$  V,  $V_{CS} = -1$  to 4 V,  $f_{CS} = 500$  kHz, ver. A

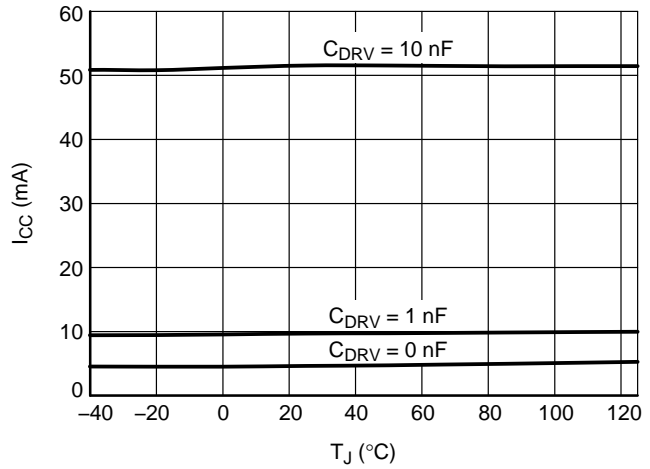

Figure 12. Current Consumption,  $V_{CC} = 12$  V,  $V_{CS} = -1$  to 4 V,  $f_{CS} = 500$  kHz, ver. D

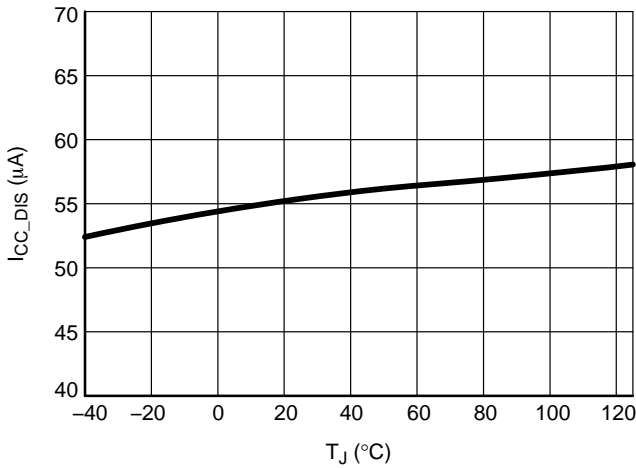

Figure 13. Current Consumption in Disable,  $V_{CC} = 12$  V,  $V_{CS} = 0$  V,  $V_{LLD} = V_{CC} - 0.1$  V

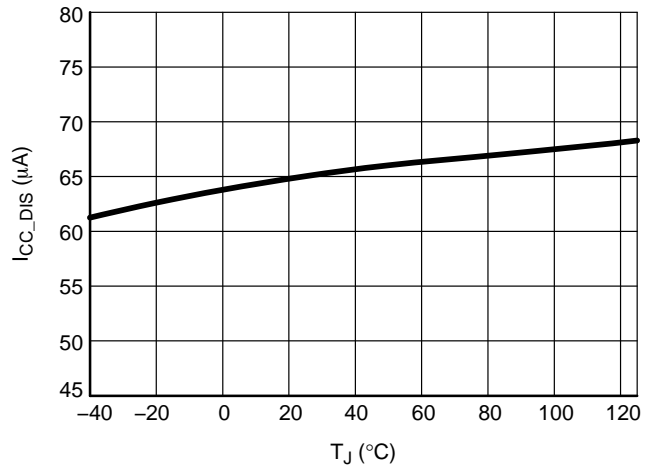

Figure 14. Current Consumption in Disable,  $V_{CC} = 12$  V,  $V_{CS} = 0$  V,  $V_{LLD} = V_{CC} - 3$  V,  $V_{TRIG} = 5$  V

TYPICAL CHARACTERISTICS

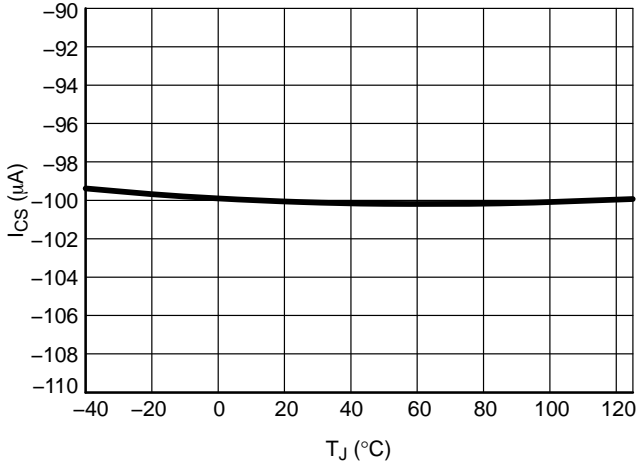

Figure 15. CS Current,  $V_{CS} = -20$  mV

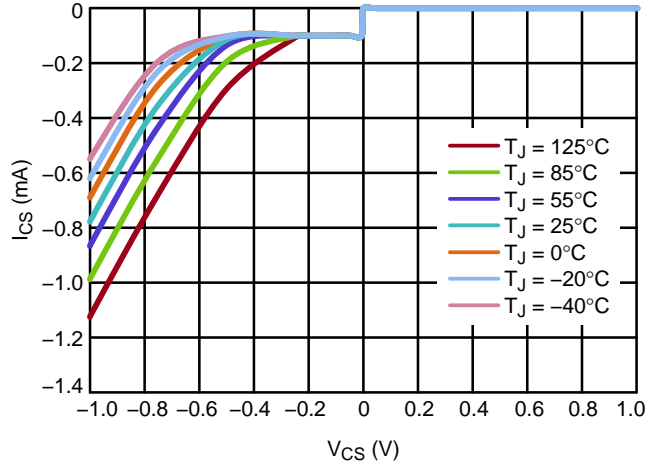

Figure 16. CS Current,  $V_{CC} = 12$  V

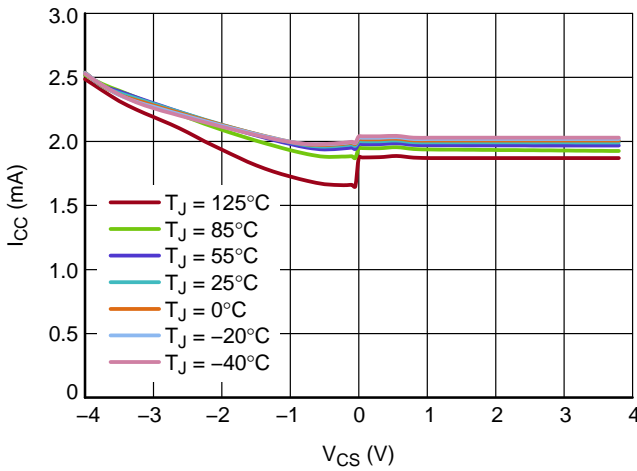

Figure 17. Supply Current vs. CS Voltage,  $V_{CC} = 12$  V

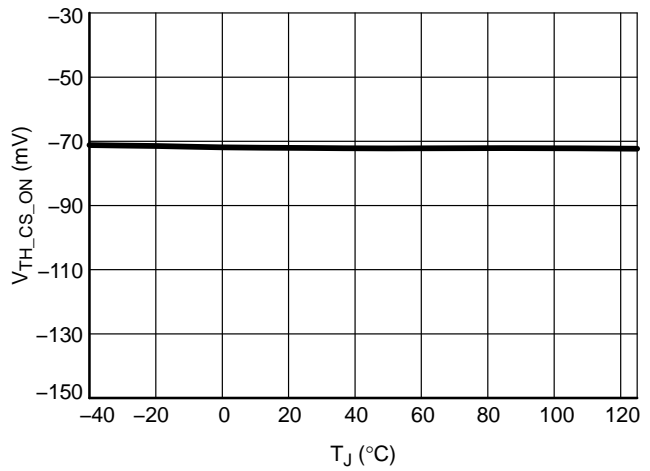

Figure 18. CS Turn-on Threshold

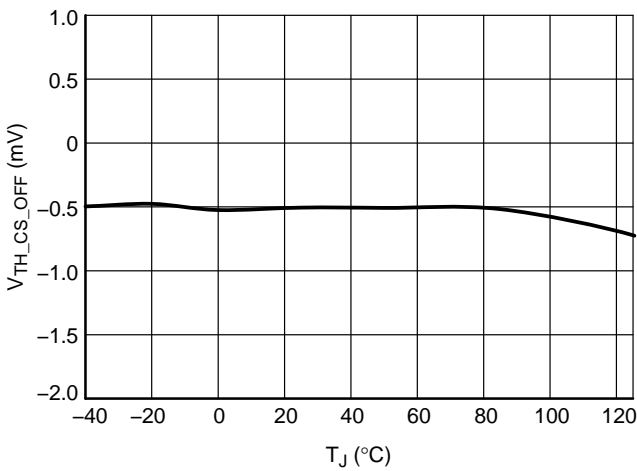

Figure 19. CS Turn-off Threshold

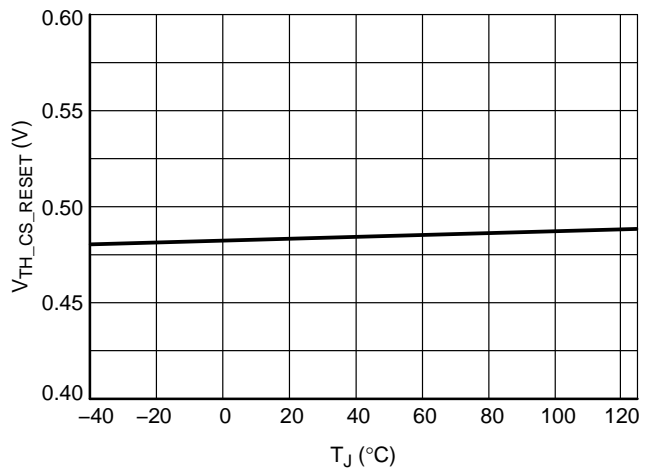

Figure 20. CS Reset Threshold

TYPICAL CHARACTERISTICS

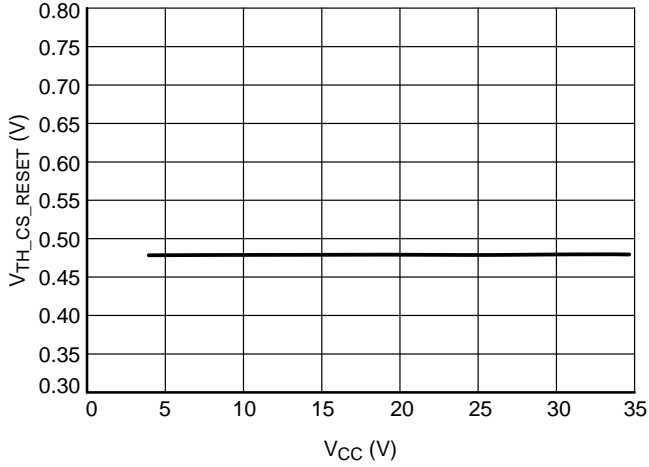

Figure 21. CS Reset Threshold

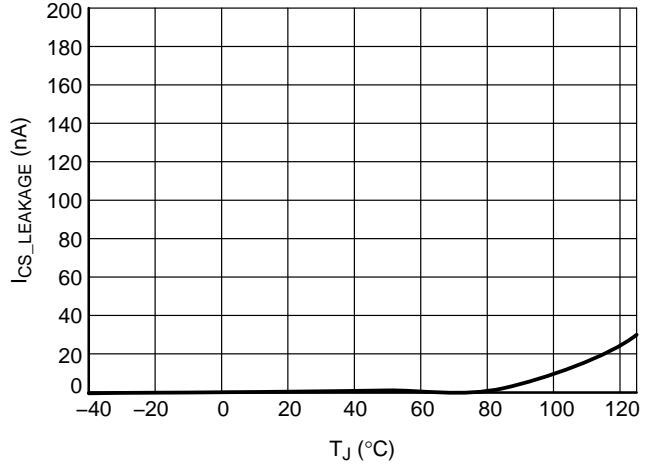

Figure 22. CS Leakage, V<sub>CS</sub> = 200 V

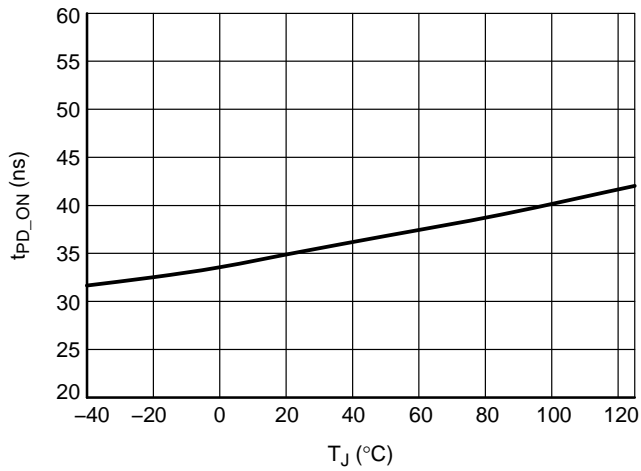

Figure 23. Propagation Delay from CS to DRV Output On

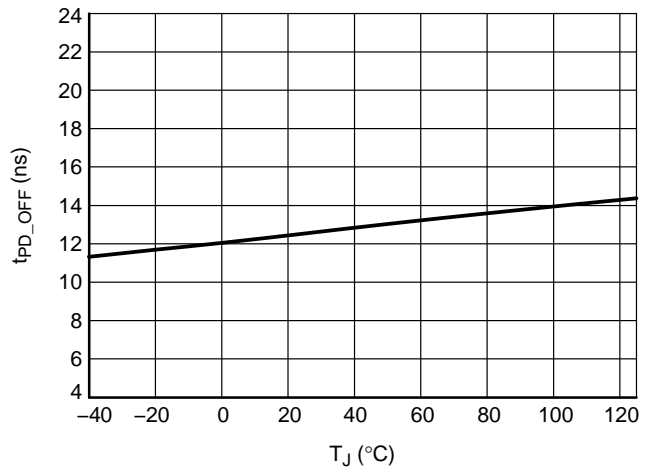

Figure 24. Propagation Delay from CS to DRV Output Off

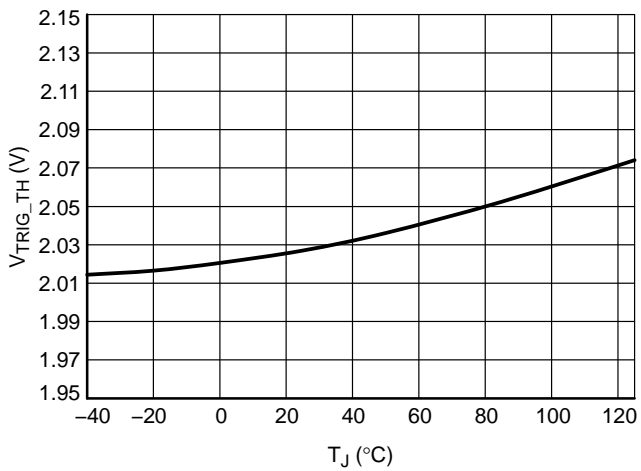

Figure 25. Trigger Threshold, V<sub>CC</sub> = 12 V

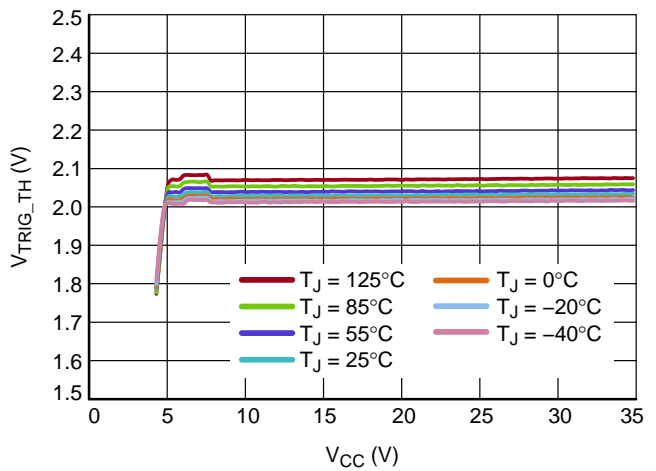

Figure 26. Trigger Threshold

TYPICAL CHARACTERISTICS

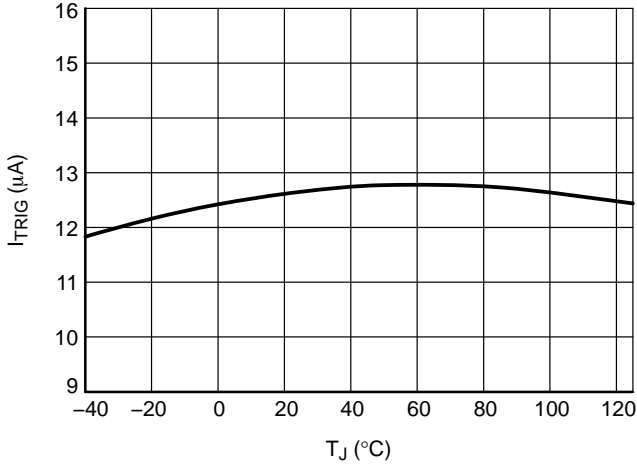

Figure 27. Trigger Pull Down Current

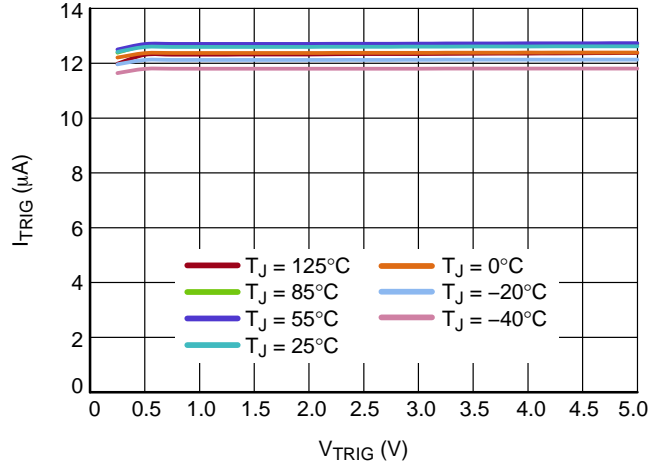

Figure 28. Trigger Pull Down Current,  $V_{CC} = 12\text{ V}$

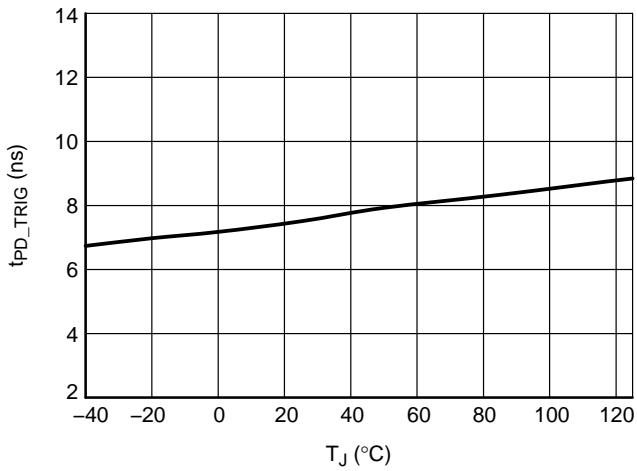

Figure 29. Propagation Delay from Trigger to Driver Output Off

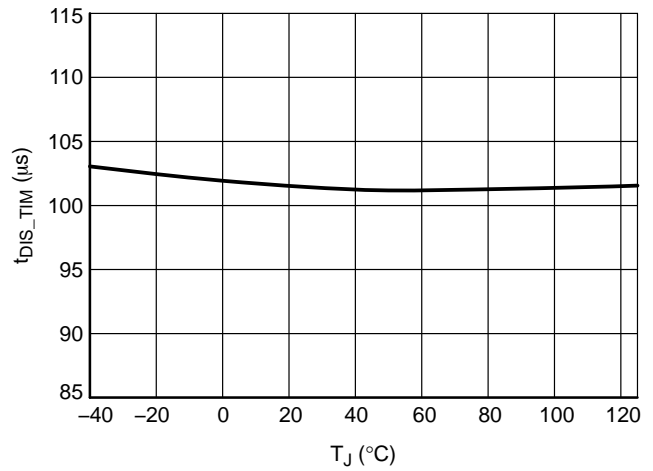

Figure 30. Delay to Disable Mode,  $V_{TRIG} = 5\text{ V}$

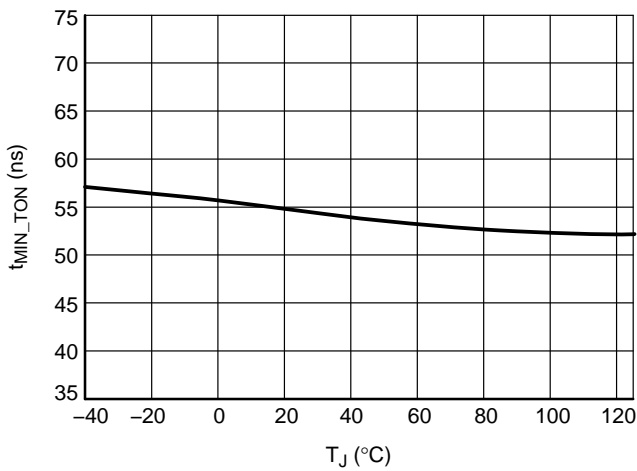

Figure 31. Minimum On-time  $R_{MIN\_TON} = 0\ \Omega$

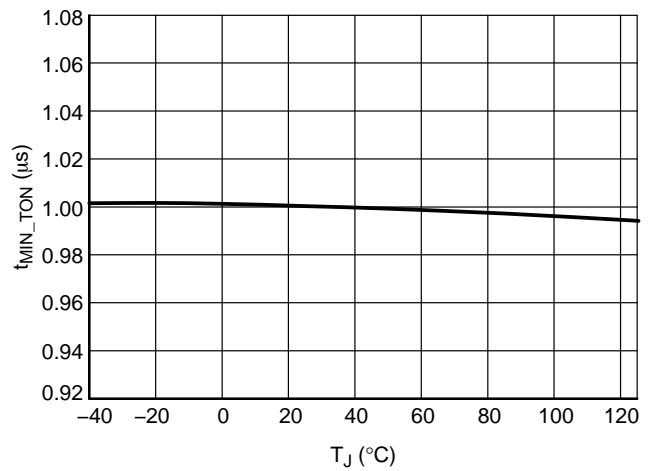

Figure 32. Minimum On-time  $R_{MIN\_TON} = 10\text{ k}\Omega$

TYPICAL CHARACTERISTICS

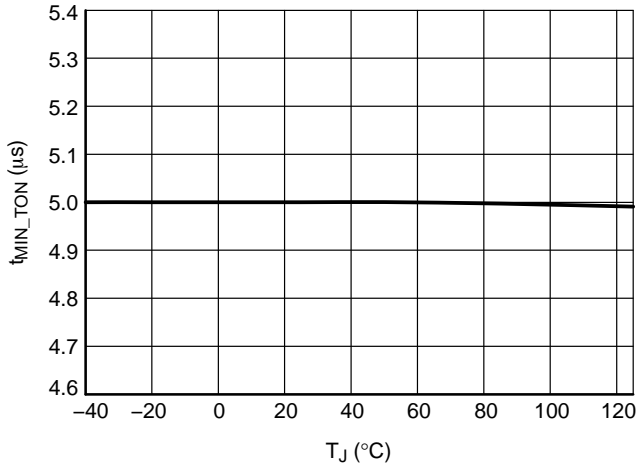

Figure 33. Minimum On-time R<sub>MIN\_TON</sub> = 50 kΩ

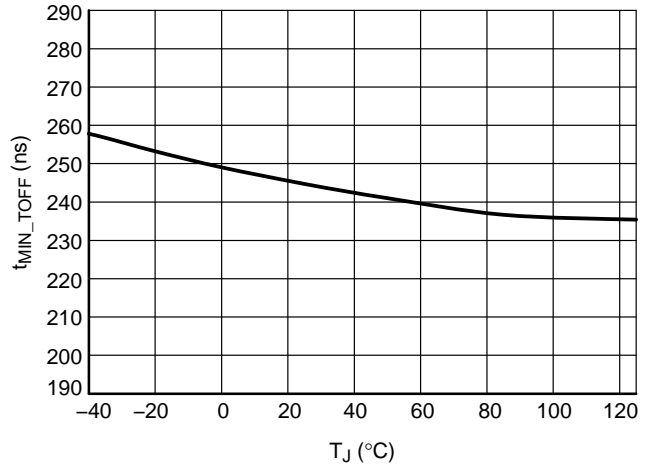

Figure 34. Minimum Off-time R<sub>MIN\_TOFF</sub> = 0 Ω

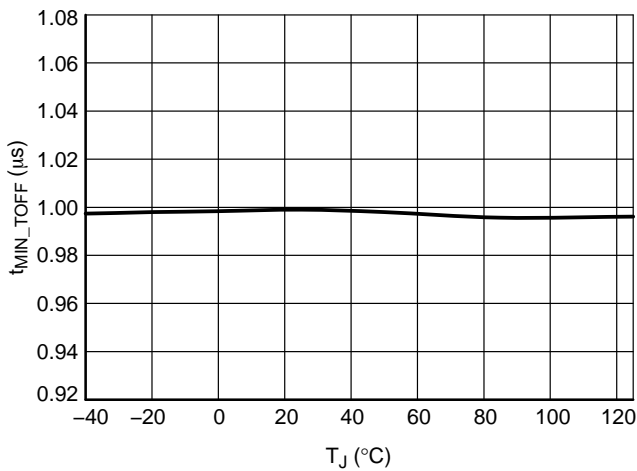

Figure 35. Minimum Off-time R<sub>MIN\_TOFF</sub> = 10 kΩ

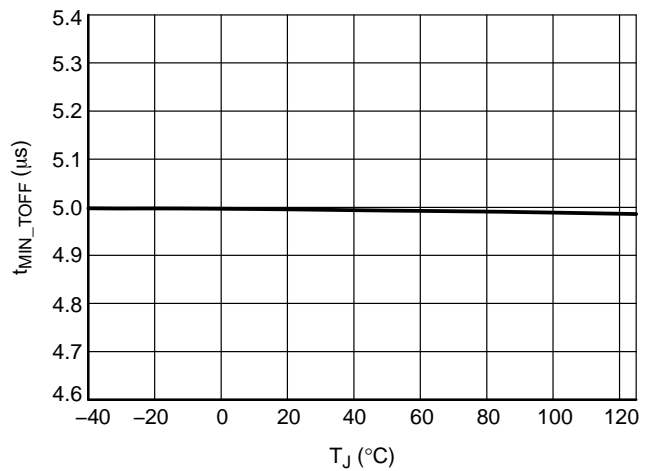

Figure 36. Minimum Off-time R<sub>MIN\_TOFF</sub> = 50 kΩ

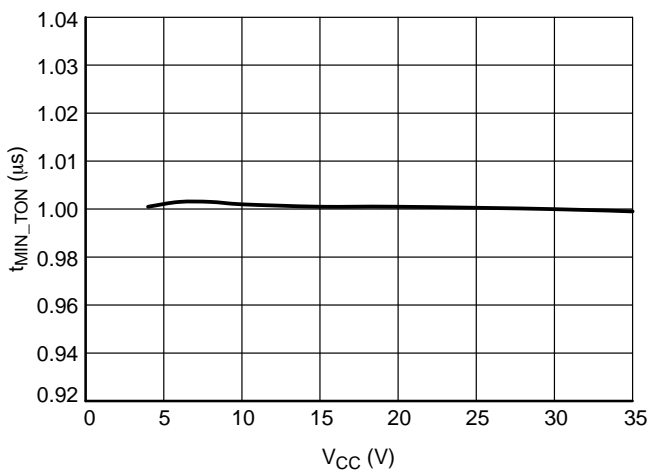

Figure 37. Minimum On-time R<sub>MIN\_TON</sub> = 10 kΩ

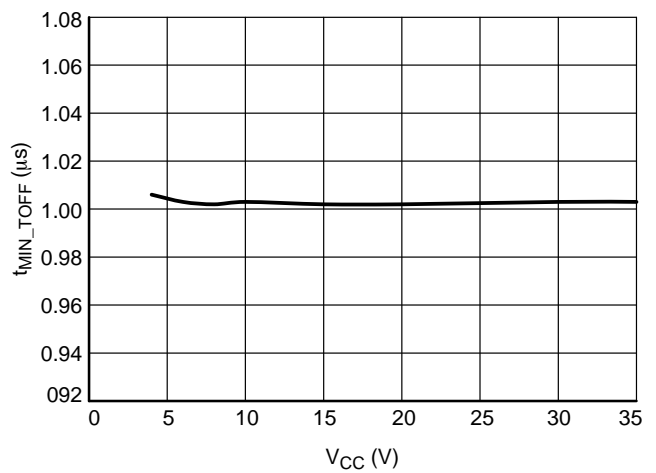

Figure 38. Minimum Off-time R<sub>MIN\_TOFF</sub> = 10 kΩ

# NCP4305

## TYPICAL CHARACTERISTICS

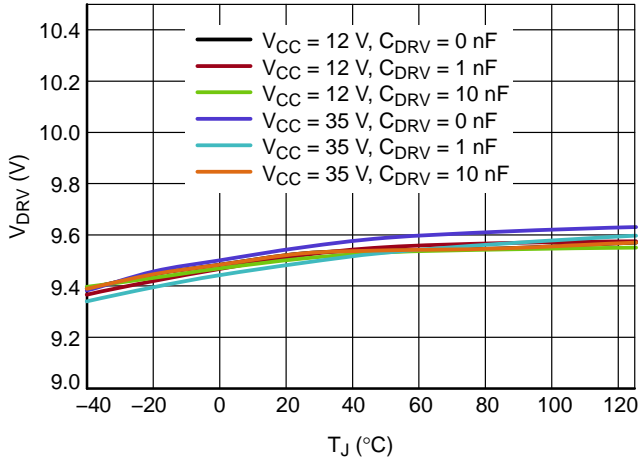

Figure 39. Driver and Output Voltage, ver. B, D and Q

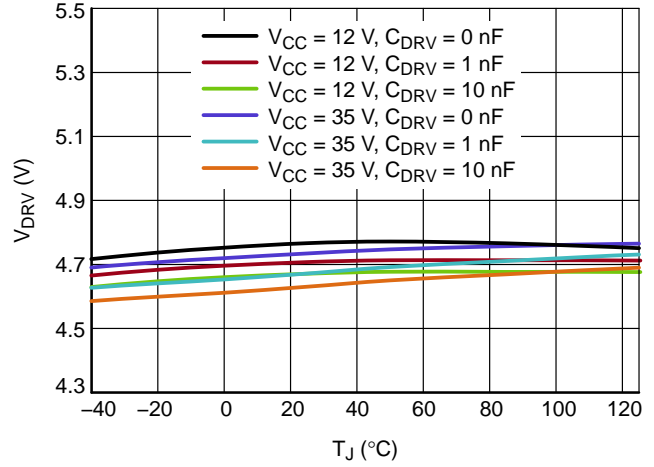

Figure 40. Driver Output Voltage, ver. A and C

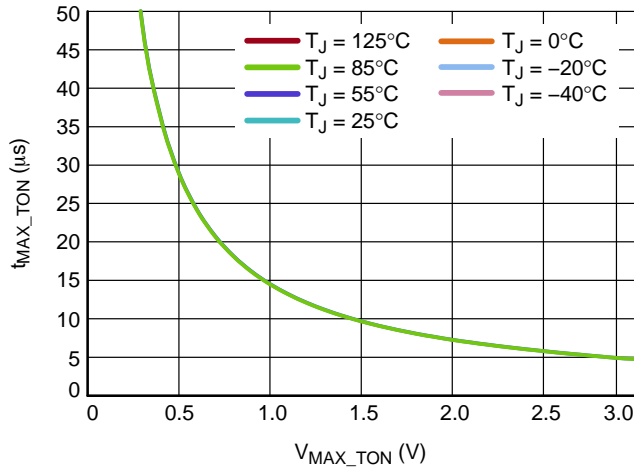

Figure 41. Maximum On-time, ver. Q

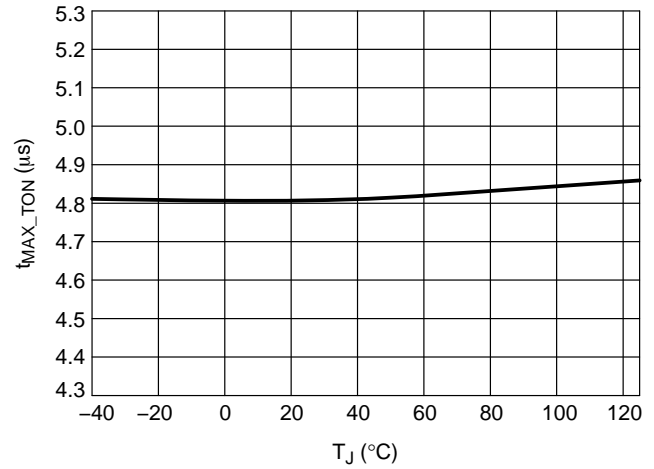

Figure 42. Maximum On-time,  $V_{MAX\_TON} = 3\text{ V}$ , ver. Q

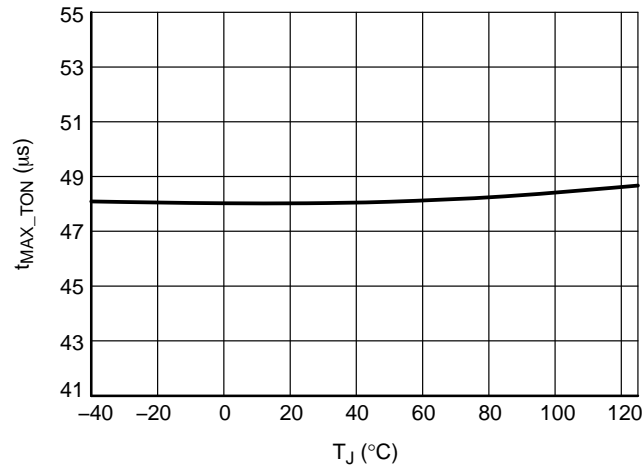

Figure 43. Maximum On-time,  $V_{MAX\_TON} = 0.3\text{ V}$ , ver. Q

## APPLICATION INFORMATION

**General description**

The NCP4305 is designed to operate either as a standalone IC or as a companion IC to a primary side controller to help achieve efficient synchronous rectification in switch mode power supplies. This controller features a high current gate driver along with high-speed logic circuitry to provide appropriately timed drive signals to a synchronous rectification MOSFET. With its novel architecture, the NCP4305 has enough versatility to keep the synchronous rectification system efficient under any operating mode.

The NCP4305 works from an available voltage with range from 4 V (A, D & Q options) or 8 V (B & C options) to 35 V (typical). The wide  $V_{CC}$  range allows direct connection to the SMPS output voltage of most adapters such as notebooks, cell phone chargers and LCD TV adapters.

Precise turn-off threshold of the current sense comparator together with an accurate offset current source allows the user to adjust for any required turn-off current threshold of the SR MOSFET switch using a single resistor. Compared to other SR controllers that provide turn-off thresholds in the range of  $-10$  mV to  $-5$  mV, the NCP4305 offers a turn-off threshold of 0 mV. When using a low  $R_{DS(on)}$  SR (1 m $\Omega$ ) MOSFET our competition, with a  $-10$  mV turn off, will turn off with 10 A still flowing through the SR FET, while our 0 mV turn off turns off the FET at 0 A; significantly reducing the turn-off current threshold and improving efficiency. Many of the competitor parts maintain a drain source voltage across the MOSFET causing the SR MOSFET to operate in the linear region to reduce turn-off time. Thanks to the 8 A sink current of the NCP4305 significantly reduces turn off time allowing for a minimal drain source voltage to be utilized and efficiency maximized.

To overcome false triggering issues after turn-on and turn-off events, the NCP4305 provides adjustable minimum on-time and off-time blanking periods. Blanking times can be adjusted independently of IC  $V_{CC}$  using external resistors connected to GND. If needed, blanking periods can be modulated using additional components.

An extremely fast turn-off comparator, implemented on the current sense pin, allows for NCP4305 implementation in CCM applications without any additional components or external triggering.

An ultrafast trigger input offers the possibility to further increase efficiency of synchronous rectification systems operated in CCM mode (for example, CCM flyback or

forward). The time delay from trigger input to driver turn off event is  $t_{PD\_TRIG}$ . Additionally, the trigger input can be used to disable the IC and activate a low consumption standby mode. This feature can be used to decrease standby consumption of an SMPS. If the trigger input is not wanted than the trigger pin can be tied to GND or an option can be chosen to replace this pin with a MAX\_TON input.

An output driver features capability to keep SR transistor closed even when there is no supply voltage for NCP4305. SR transistor drain voltage goes up and down during SMPS operation and this is transferred through drain gate capacitance to gate and may turn on transistor. NCP4305 uses this pulsing voltage at SR transistor gate (DRV pin) and uses it internally to provide enough supply to activate internal driver sink transistor. DRV voltage is pulled low (not to zero) thanks to this feature and eliminate the risk of turned on SR transistor before enough  $V_{CC}$  is applied to NCP4305.

Some IC versions include a MAX\_TON circuit that helps a quasi resonant (QR) controller to work in CCM mode when a heavy load is present like in the example of a printer's motor starting up.

Finally, the NCP4305 features a special pin (LLD) that can be used to reduce gate driver voltage clamp according to application load conditions. This feature helps to reduce issues with transition from disabled driver to full driver output voltage and back. Disable state can be also activated through this pin to decrease power consumption in no load conditions. If the LLD feature is not wanted then the LLD pin can be tied to GND.

**Current Sense Input**

Figure 44 shows the internal connection of the CS circuitry on the current sense input. When the voltage on the secondary winding of the SMPS reverses, the body diode of M1 starts to conduct current and the voltage of M1's drain drops approximately to  $-1$  V. The CS pin sources current of 100  $\mu$ A that creates a voltage drop on the  $R_{SHIFT\_CS}$  resistor (resistor is optional, we recommend shorting this resistor). Once the voltage on the CS pin is lower than  $V_{TH\_CS\_ON}$  threshold, M1 is turned-on. Because of parasitic impedances, significant ringing can occur in the application. To overcome false sudden turn-off due to mentioned ringing, the minimum conduction time of the SR MOSFET is activated. Minimum conduction time can be adjusted using the  $R_{MIN\_TON}$  resistor.

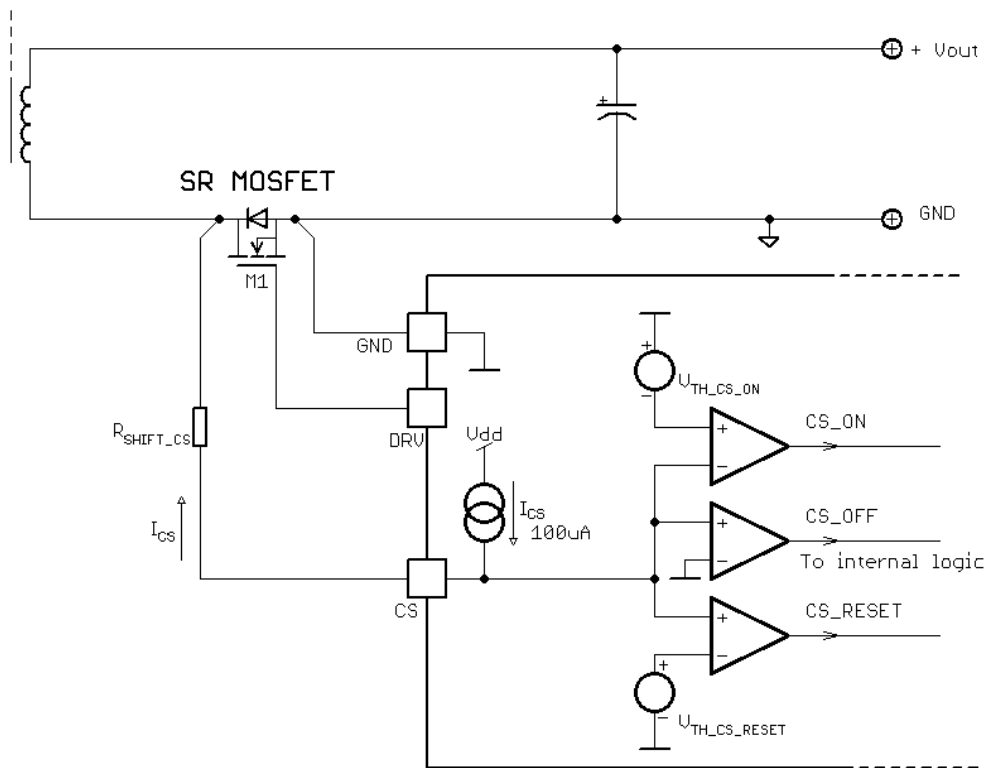

Figure 44. Current Sensing Circuitry Functionality

The SR MOSFET is turned-off as soon as the voltage on the CS pin is higher than  $V_{TH\_CS\_OFF}$  (typically  $-0.5\text{ mV}$  minus any voltage dropped on the optional  $R_{SHIFT\_CS}$ ). For the same ringing reason, a minimum off-time timer is asserted once the  $V_{CS}$  goes above  $V_{TH\_CS\_RESET}$ . The minimum off-time can be externally adjusted using  $R_{MIN\_TOFF}$  resistor. The minimum off-time generator can be re-triggered by MIN\_TOFF reset comparator if some spurious ringing occurs on the CS input after SR MOSFET turn-off event. This feature significantly simplifies SR system implementation in flyback converters.

In an LLC converter the SR MOSFET M1 channel conducts while secondary side current is decreasing (refer to

Figure 45). Therefore the turn-off current depends on MOSFET  $R_{DSON}$ . The  $-0.5\text{ mV}$  threshold provides an optimum switching period usage while keeping enough time margin for the gate turn-off. The  $R_{SHIFT\_CS}$  resistor provides the designer with the possibility to modify (increase) the actual turn-on and turn-off secondary current thresholds. To ensure proper switching, the  $min\_toff$  timer is reset, when the  $V_{DS}$  of the MOSFET rings and falls down past the  $V_{TH\_CS\_RESET}$ . The minimum off-time needs to expire before another drive pulse can be initiated. Minimum off-time timer is started again when  $V_{DS}$  rises above  $V_{TH\_CS\_RESET}$ .



# NCP4305

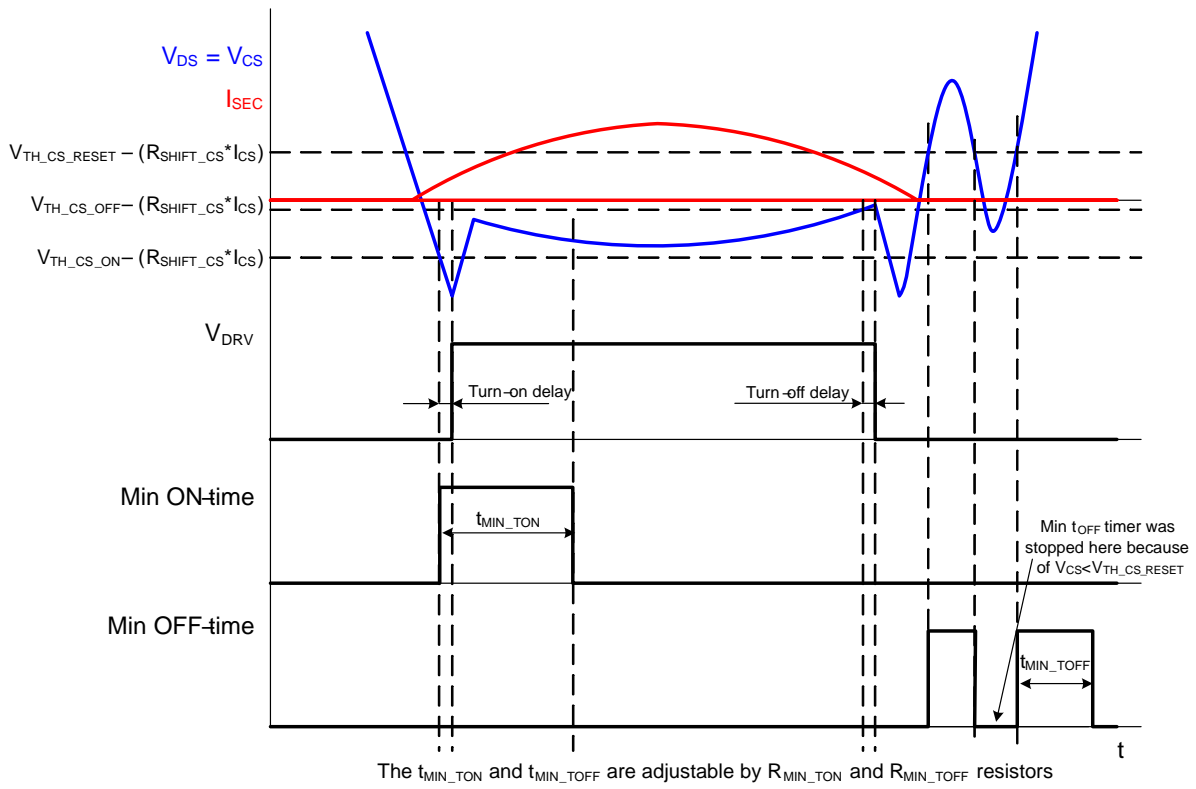

Figure 45. CS Input Comparators Thresholds and Blanking Periods Timing in LLC

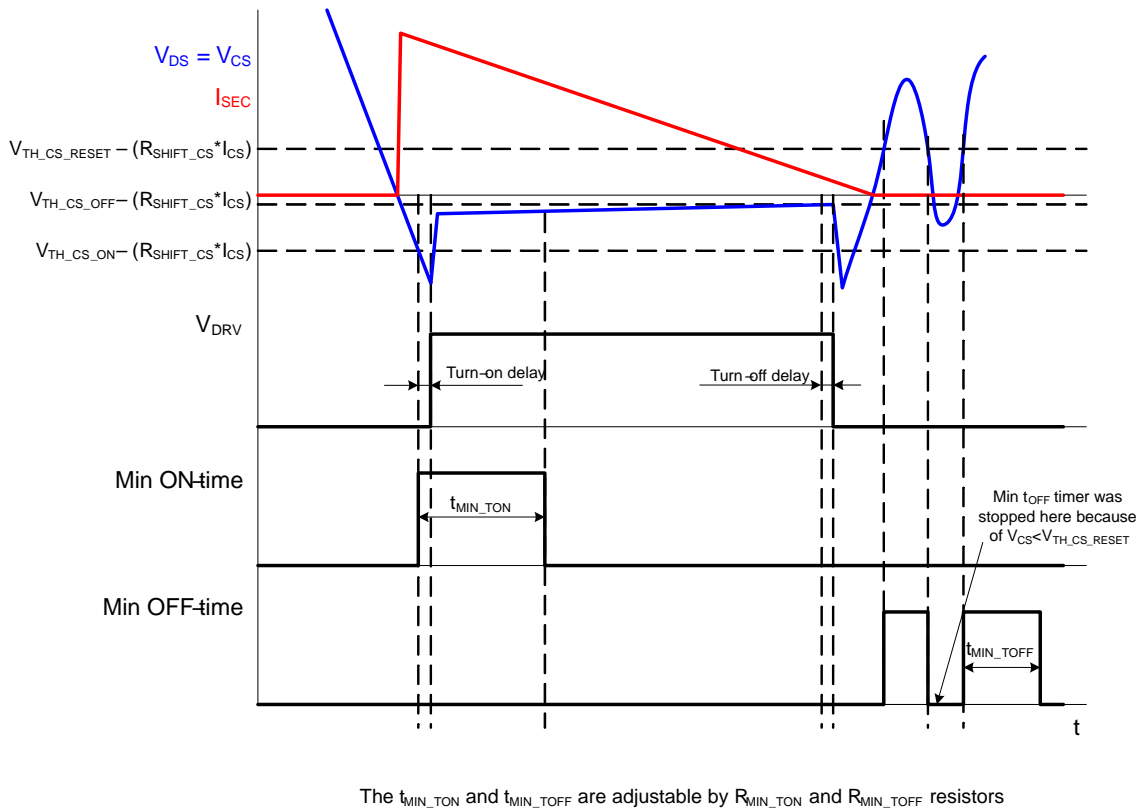

Figure 46. CS Input Comparators Thresholds and Blanking Periods Timing in Flyback

## NCP4305

If no  $R_{SHIFT\_CS}$  resistor is used, the turn-on, turn-off and  $V_{TH\_CS\_RESET}$  thresholds are fully given by the CS input specification (please refer to electrical characteristics table). The CS pin offset current causes a voltage drop that is equal to:

$$V_{RSHIFT\_CS} = R_{SHIFT\_CS} * I_{CS} \quad (\text{eq. 1})$$

Final turn-on and turn off thresholds can be then calculated as:

$$V_{CS\_TURN\_ON} = V_{TH\_CS\_ON} - (R_{SHIFT\_CS} * I_{CS}) \quad (\text{eq. 2})$$

$$V_{CS\_TURN\_OFF} = V_{TH\_CS\_OFF} - (R_{SHIFT\_CS} * I_{CS}) \quad (\text{eq. 3})$$

$$V_{CS\_RESET} = V_{TH\_CS\_RESET} - (R_{SHIFT\_CS} * I_{CS}) \quad (\text{eq. 4})$$

Note that  $R_{SHIFT\_CS}$  impact on turn-on and  $V_{TH\_CS\_RESET}$  thresholds is less critical than its effect on the turn-off threshold.

It should be noted that when using a SR MOSFET in a through hole package the parasitic inductance of the MOSFET package leads (refer to Figure 47) causes a turn-off current threshold increase. The current that flows through the SR MOSFET experiences a high  $\Delta i(t)/\Delta t$  that induces an error voltage on the SR MOSFET leads due to their parasitic inductance. This error voltage is proportional to the derivative of the SR MOSFET current; and shifts the CS input voltage to zero when significant current still flows through the MOSFET channel. As a result, the SR MOSFET is turned-off prematurely and the efficiency of the SMPS is not optimized – refer to Figure 48 for a better understanding.

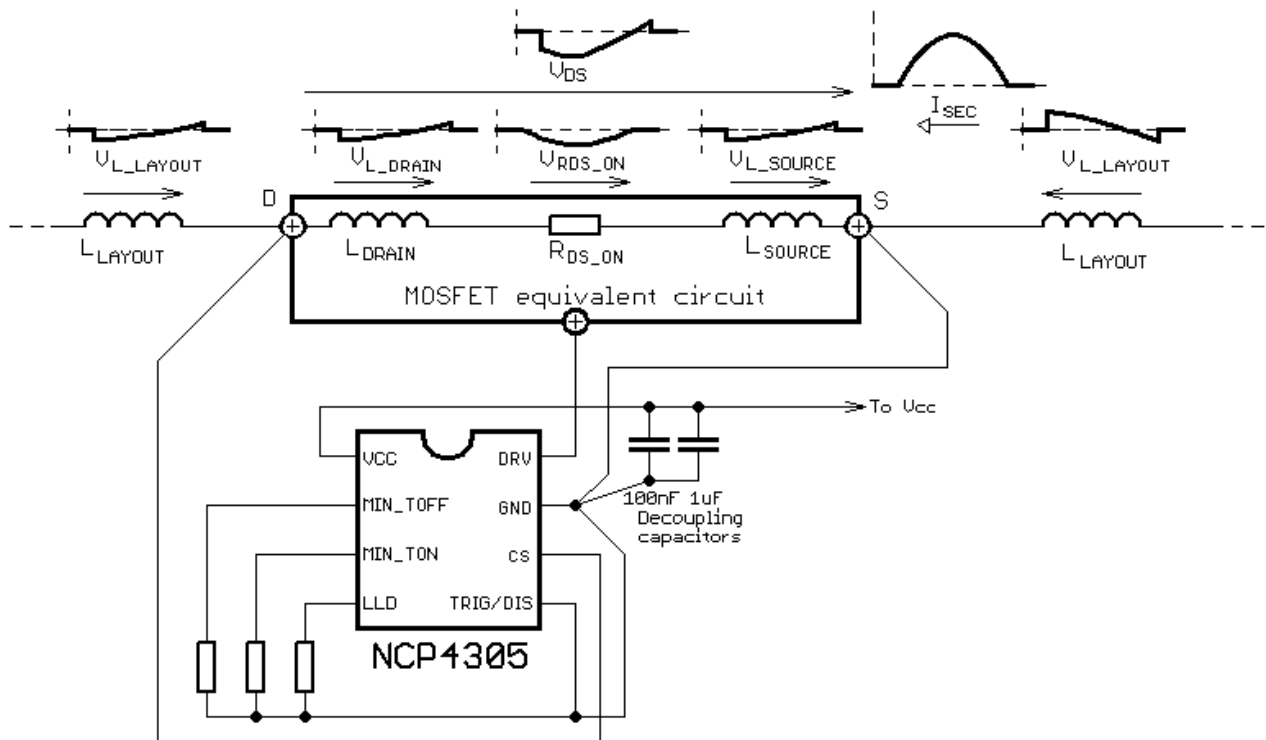
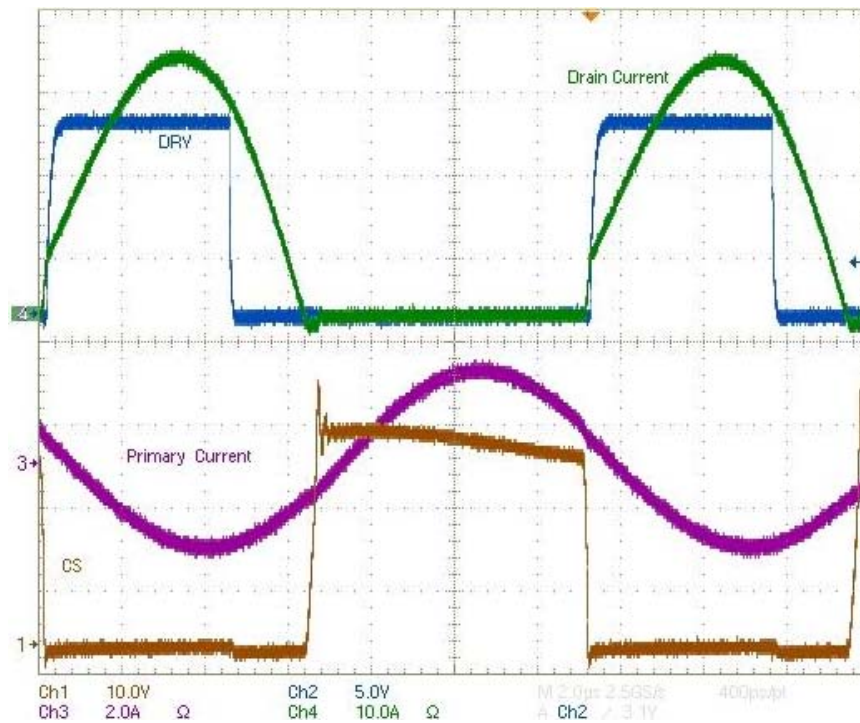

Figure 47. SR System Connection Including MOSFET and Layout Parasitic Inductances in LLC Application

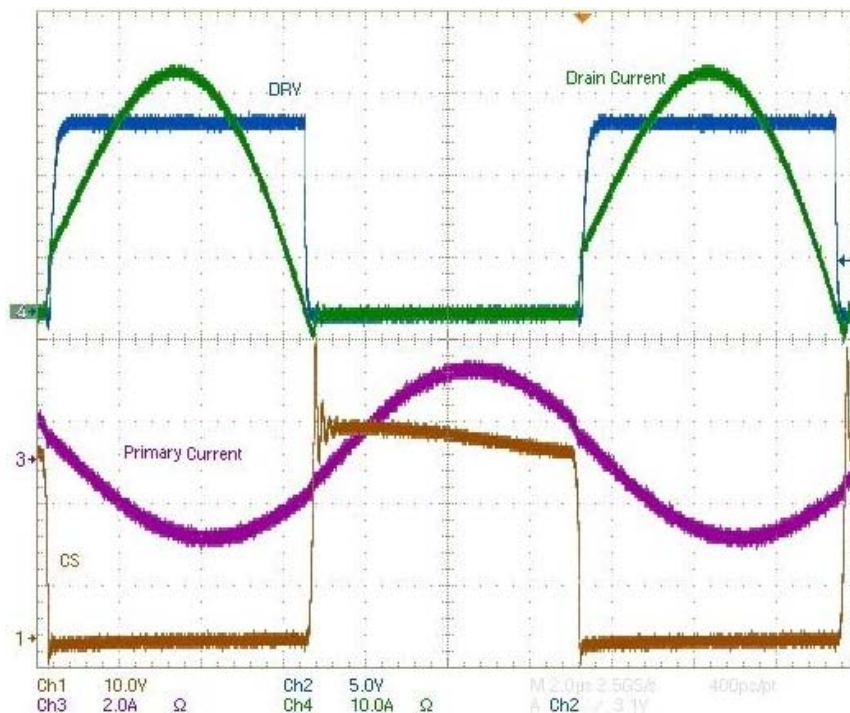

**Figure 48. Waveforms From SR System Implemented in LLC Application and Using MOSFET in TO220 Package With Long Leads – SR MOSFET channel Conduction Time is Reduced**

Note that the efficiency impact caused by the error voltage due to the parasitic inductance increases with lower MOSFETs  $R_{DS(on)}$  and/or higher operating frequency.

It is thus beneficial to minimize SR MOSFET package leads length in order to maximize application efficiency. The optimum solution for applications with high secondary

current  $\Delta i/\Delta t$  and high operating frequency is to use lead-less SR MOSFET i.e. SR MOSFET in SMT package. The parasitic inductance of a SMT package is negligible causing insignificant CS turn-off threshold shift and thus minimum impact to efficiency (refer to Figure 49).



**Figure 49. Waveforms from SR System Implemented in LLC Application and Using MOSFET in SMT Package with Minimized Parasitic Inductance – SR MOSFET Channel Conduction Time is Optimized**

It can be deduced from the above paragraphs on the induced error voltage and parameter tables that turn-off threshold precision is quite critical. If we consider a SR MOSFET with  $R_{DS(on)}$  of  $1\text{ m}\Omega$ , the  $1\text{ mV}$  error voltage on the CS pin results in a  $1\text{ A}$  turn-off current threshold difference; thus the PCB layout is very critical when implementing the SR system. Note that the CS turn-off comparator is referred to the GND pin. Any parasitic impedance (resistive or inductive – even on the magnitude of  $\text{m}\Omega$  and  $\text{nH}$  values) can cause a high error voltage that is then evaluated by the CS comparator. Ideally the CS turn-off comparator should detect voltage that is caused by secondary current directly on the SR MOSFET channel resistance. In reality there will be small parasitic impedance on the CS path due to the bonding wires, leads and soldering. To assure the best efficiency results, a Kelvin connection of

the SR controller to the power circuitry should be implemented. The GND pin should be connected to the SR MOSFET source soldering point and current sense pin should be connected to the SR MOSFET drain soldering point – refer to Figure 47. Using a Kelvin connection will avoid any impact of PCB layout parasitic elements on the SR controller functionality; SR MOSFET parasitic elements will still play a role in attaining an error voltage. Figure 50 and Figure 51 show examples of SR system layouts using MOSFETs in TO220 and SMT packages. It is evident that the MOSFET leads should be as short as possible to minimize parasitic inductances when using packages with leads (like TO220). Figure 51 shows how to layout design with two SR MOSFETs in parallel. It has to be noted that it is not easy task and designer has to paid lot of attention to do symmetric Kelvin connection.

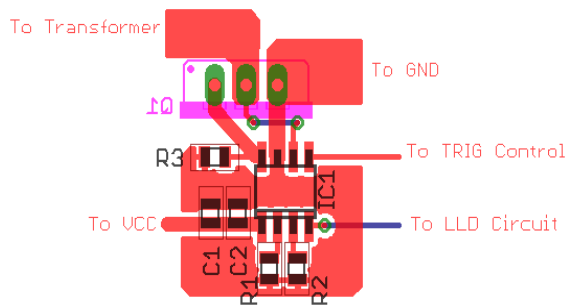

**Figure 50. Recommended Layout When Using SR MOSFET in TO220 Package**

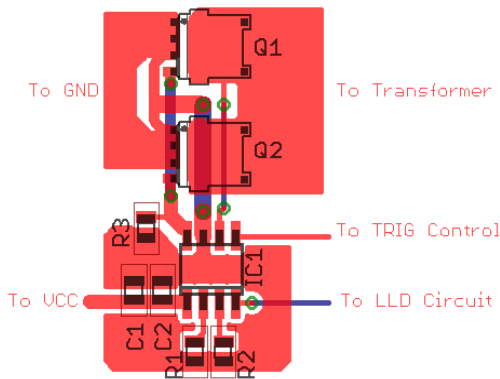

**Figure 51. Recommended Layout When Using SR MOSFET in SMT Package (2x SO8 FL)**

**Trigger/Disable input**

The NCP4305 features an ultrafast trigger input that exhibits a maximum of  $t_{PD\_TRIG}$  delay from its activation to

the start of SR MOSFET turn-off of process. This input can be used in applications operated in deep Continuous Conduction Mode (CCM) to further increase efficiency and/or to activate disable mode of the SR driver in which the consumption of the NCP4305 is reduced to maximum of  $I_{CC\_DIS}$ .

NCP4305 is capable to turn-off the SR MOSFET reliably in CCM applications just based on CS pin information only, without using the trigger input. However, natural delay of the ZCD comparator and DRV turn-off delay increase overlap between primary and secondary MOSFETs switching (also known as cross conduction). If one wants to achieve absolutely maximum efficiency with deep CCM applications, then the trigger signal coming from the primary side should be applied to the trigger pin. The trigger input then turns the SR MOSFET off slightly before the secondary winding voltage reverses. There are several possibilities for transferring the trigger signal from the primary to the secondary side – refer to Figures 66 and 67.

The trigger signal is blanked for  $t_{TRIGBLANK}$  after the DRV turn-on process has begun. The blanking technique is used to increase trigger input noise immunity against the parasitic ringing that is present during the turn on process due to the SMPS layout. The trigger input is superseded the CS input except trigger blanking period. TRIG/DIS signal turns the SR MOSFET off or prohibits its turn-on when the Trigger/Disable pin is pulled above  $V_{TRIG\_TH}$ .

The SR controller enters disable mode when the trigger pin is pulled-up for more than  $t_{DIS\_TIM}$ . In disable mode the IC consumption is significantly reduced. To recover from disable mode and enter normal operation, the TRIG/DIS pin is pulled low at least for  $t_{DIS\_END}$ .

## NCP4305

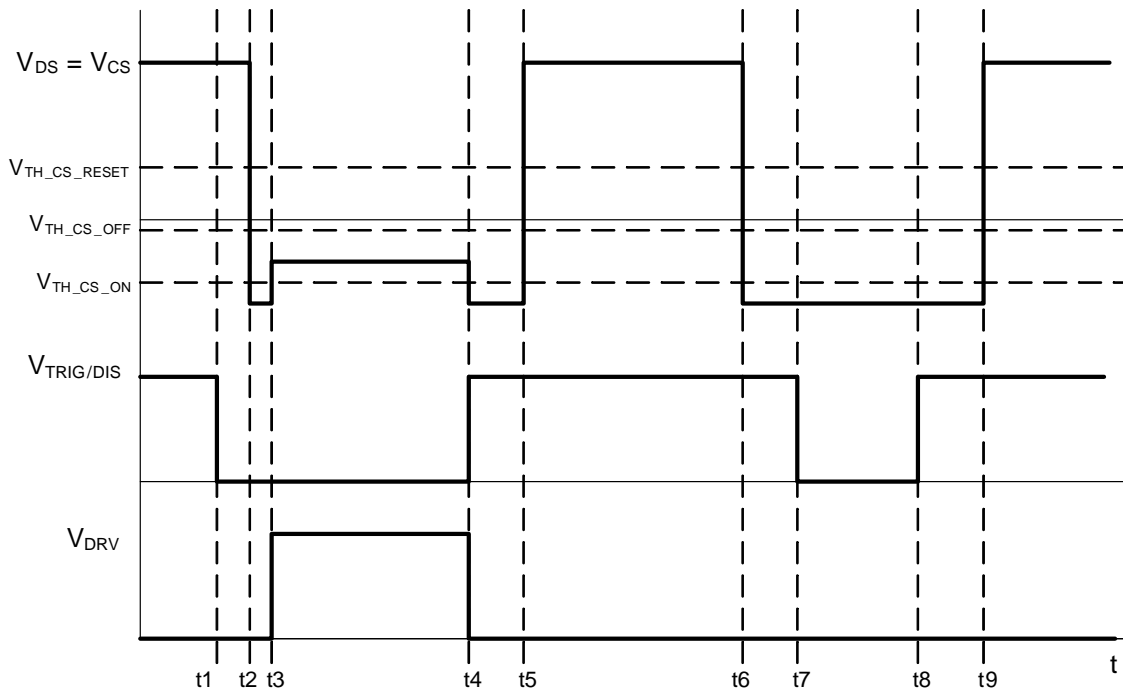
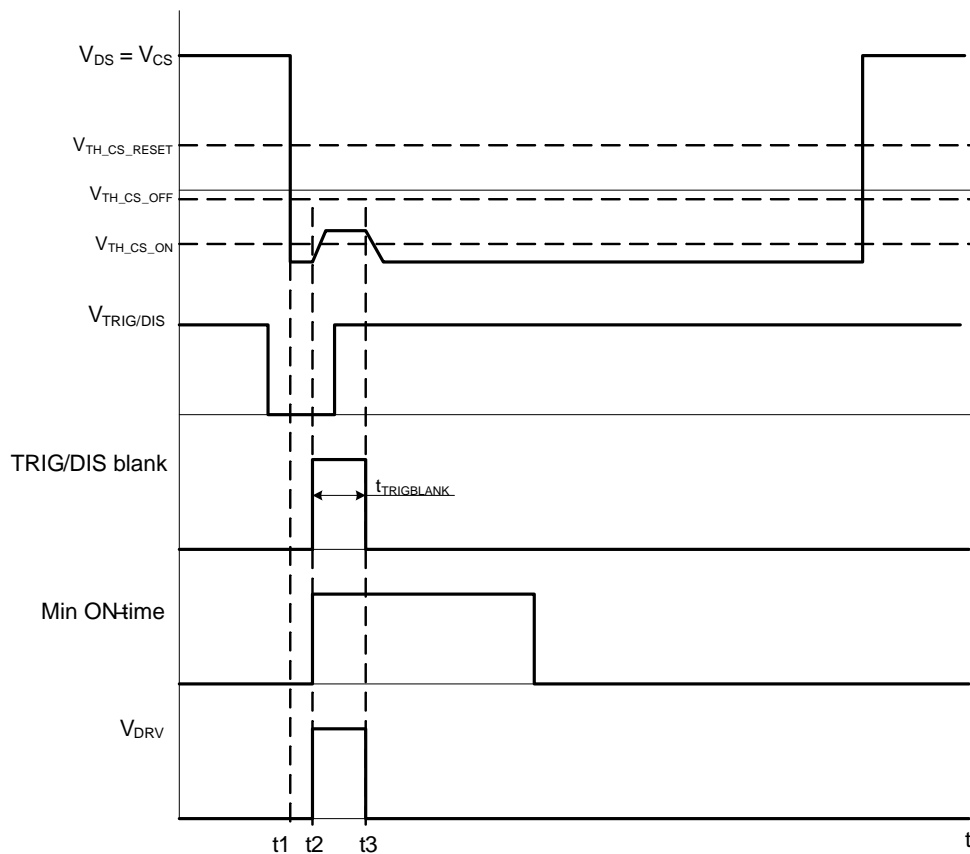

**Figure 52. Trigger Input Functionality Waveforms Using the Trigger to Turn-off and Block the DRV Signal**

Figure 52 shows basic Trigger/Disable input functionality. At  $t_1$  the Trigger/Disable pin is pulled low to enter into normal operation. At  $t_2$  the CS pin is dropped below the  $V_{TH\_CS\_ON}$ , signaling to the NCP4305 to start to turn the SR MOSFET on. At  $t_3$  the NCP4305 begins to drive the MOSFET. At  $t_4$ , the SR MOSFET is conducting and the Trigger/Disable pin is pulled high. This high signal on the

Trigger/Disable pin almost immediately turns off the drive to the SR MOSFET, turning off the MOSFET. The DRV is not turned-on in other case ( $t_6$ ) because the trigger pin is high in the time when CS pin signal crosses turn-on threshold. This figure clearly shows that the DRV can be asserted only on falling edge of the CS pin signal in case the trigger input is at low level ( $t_2$ ).

# NCP4305



**Figure 53. Trigger Input Functionality Waveforms – Trigger Blanking**

In Figure 53 above, at time  $t_1$  the CS pin falls below the  $V_{TH\_CS\_ON}$  while the Trigger is low setting in motion the DRV signal that appears at  $t_2$ . At time  $t_2$  the DRV signal and Trigger blanking clock begin. Trigger/Disable signal goes high shortly after time  $t_2$ . Due to the Trigger blanking clock ( $t_{TRIG\_BLANK}$ ) the Trigger's high signal does not affect the DRV signal until the  $t_{TRIG\_BLANK}$  timer has expired. At time  $t_3$  the Trigger/Disable signal is re evaluated and the DRV signal is turned off. The TRIG/DIS input is blanked for  $t_{TRIGBLANK}$  after DRV set signal to avoid undesirable

behavior during SR MOSFET turn-on event. The blanking time in combination with high threshold voltage ( $V_{TRIG\_TH}$ ) prevent triggering on ringing and spikes that are present on the TRIG/DIS input pin during the SR MOSFET turn-on process. Controller's response to the narrow pulse on the Trigger/Disable pin is depicted in Figure 53 – this short trigger pulse enables to turn the DRV on for  $t_{TRIG\_BLANK}$ . Note that this case is valid only if device not entered disable mode before.

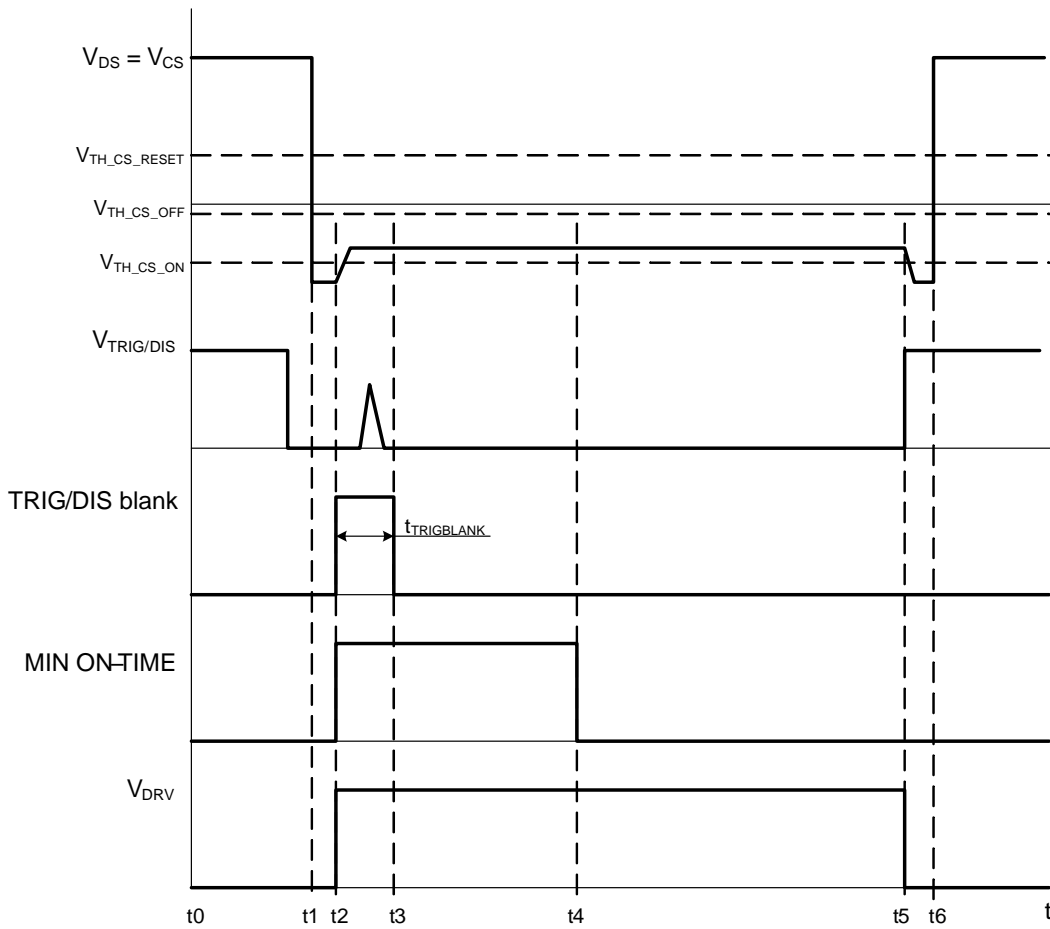
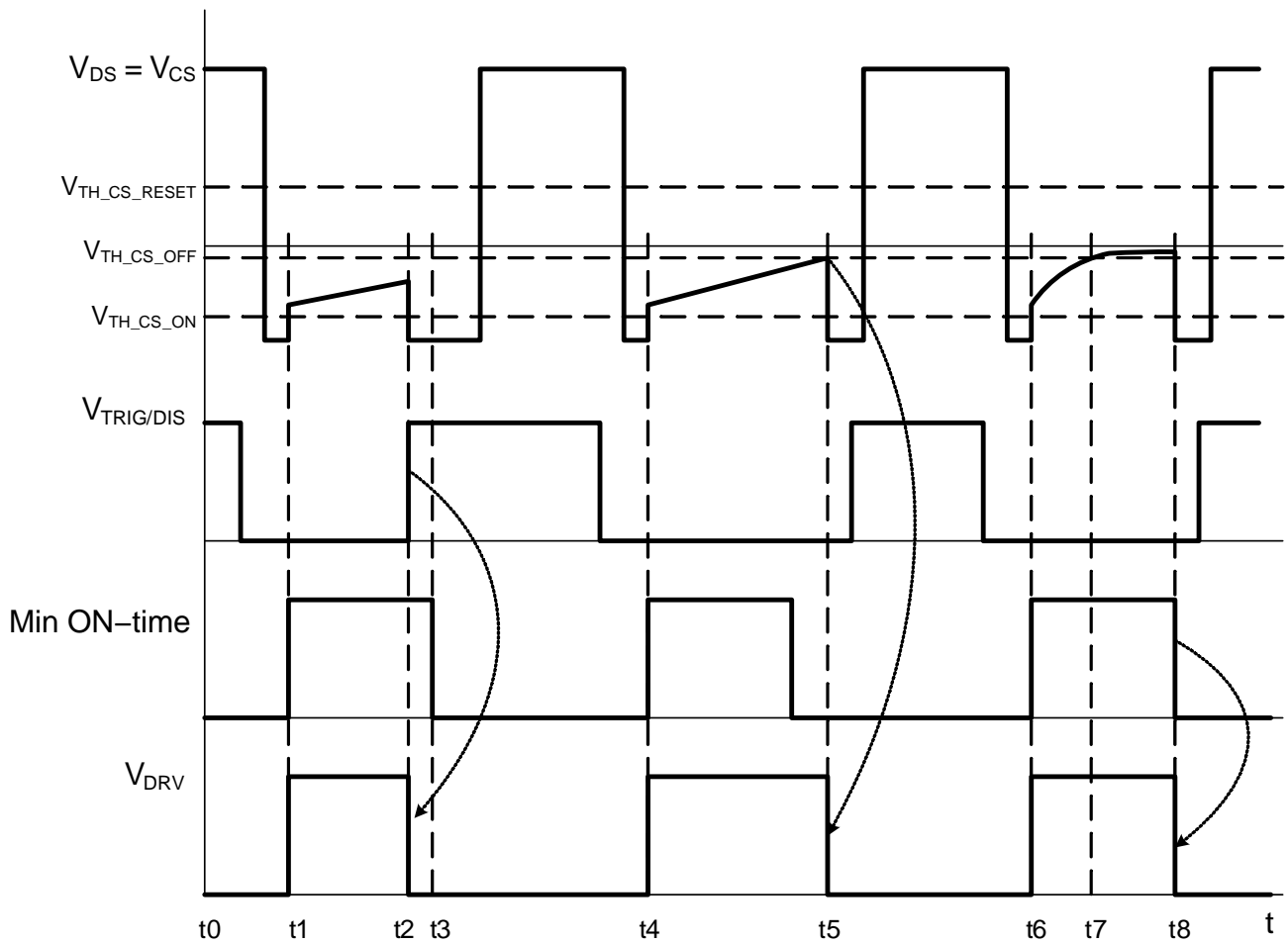

**Figure 54. Trigger Input Functionality Waveforms – Trigger Blanking Acts Like a Filter**

Figure 54 above shows almost the same situation as in Figure 53 with one main exception; the TRIG/DIS signal was not high after trigger blanking timer expired so the DRV signal remains high. The advantage of the trigger blanking time during DRV turn-on is evident from Figure 54 since it acts like a filter on the Trigger/Disable pin. Rising edge of

the DRV signal may cause spikes on the trigger input. If it wasn't for the TRIG/DIS blanking these spikes, in combination with ultra-fast performance of the trigger logic, could turn the SR MOSFET off in an inappropriate time.





**Figure 55. Trigger Input Functionality Waveforms – Trigger Over Ride, CS Turn Off and Min On-time**

Figure 55 depicts all possible driver turn-off events in details when correct  $V_{CC}$  is applied. Controller driver is disabled based on trigger input signal in time  $t_2$ ; the trigger input overrides the minimum on-time period.

Driver is turned-off according to the CS ( $V_{DS}$ ) signal ( $t_5$  marker) and when minimum on-time period elapsed already. TRIG/DIS signal needs to be LOW during this event.

If the CS ( $V_{DS}$ ) voltage reaches  $V_{TH\_CS\_OFF}$  threshold before minimum on-time period ( $t_7$ ) and the Trigger/Disable pin is low the DRV is turned-off on the falling edge of the minimum on-time period ( $t_8$  time marker in Figure 55). This demonstrates the fact that the Trigger over rides the minimum on-time. Minimum on-time has higher priority than the CS signal.

In Figure 56 the trigger input is low the whole time and the DRV pulses are purely a function of the CS signal and the minimum on-time. The first DRV pulse terminated based on the CS signal and another two DRV pulses are prolonged till the minimum on-time period end despite the CS signal crosses the  $V_{TH\_CS\_OFF}$  threshold earlier.

If a minimum on-time is too long the situation that occurs after time marker  $t_6$  Figure 56 can occur, is not correct and should be avoided. The minimum  $t_{ON}$  period should be selected shorter to overcome situation that the SR MOSFET is turned-on for too long time. The secondary current then changes direction and energy flows back to the transformer that result in reduced application efficiency and also in excessive ringing on the primary and secondary MOSFETs.

# NCP4305

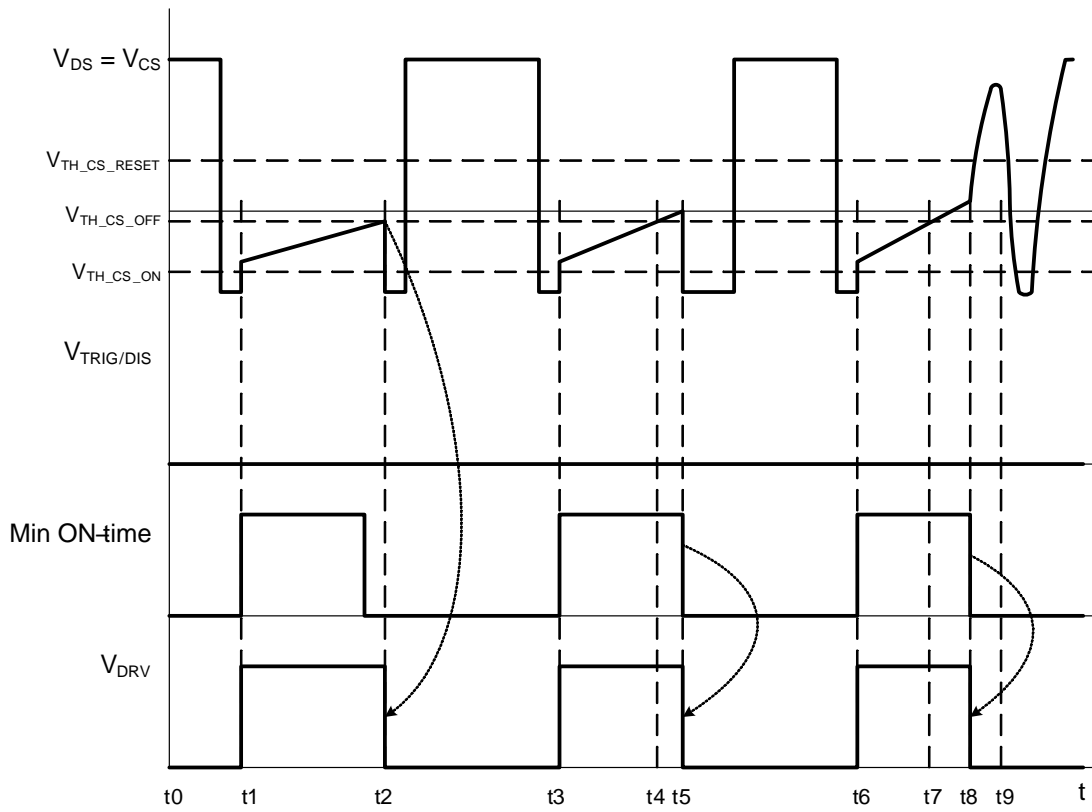
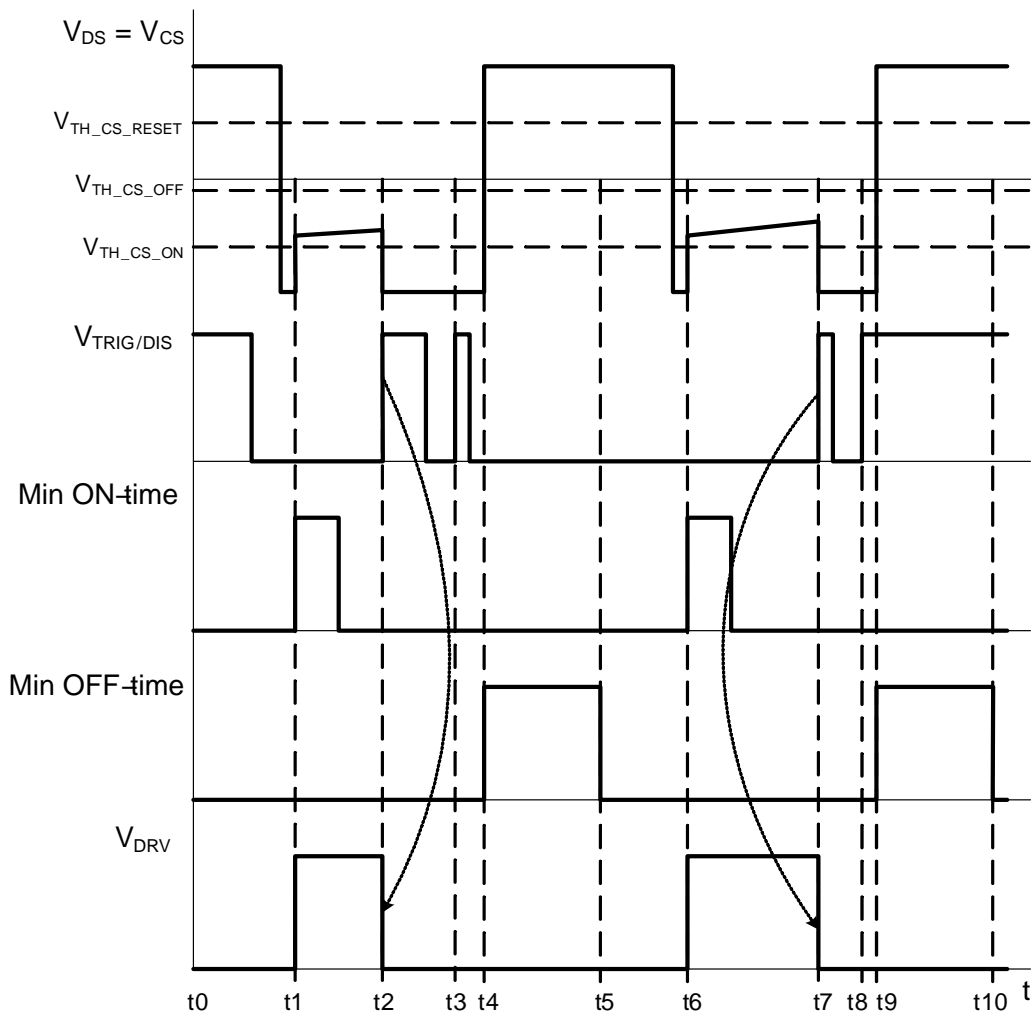

Figure 56. Minimum On-Time Priority

# NCP4305

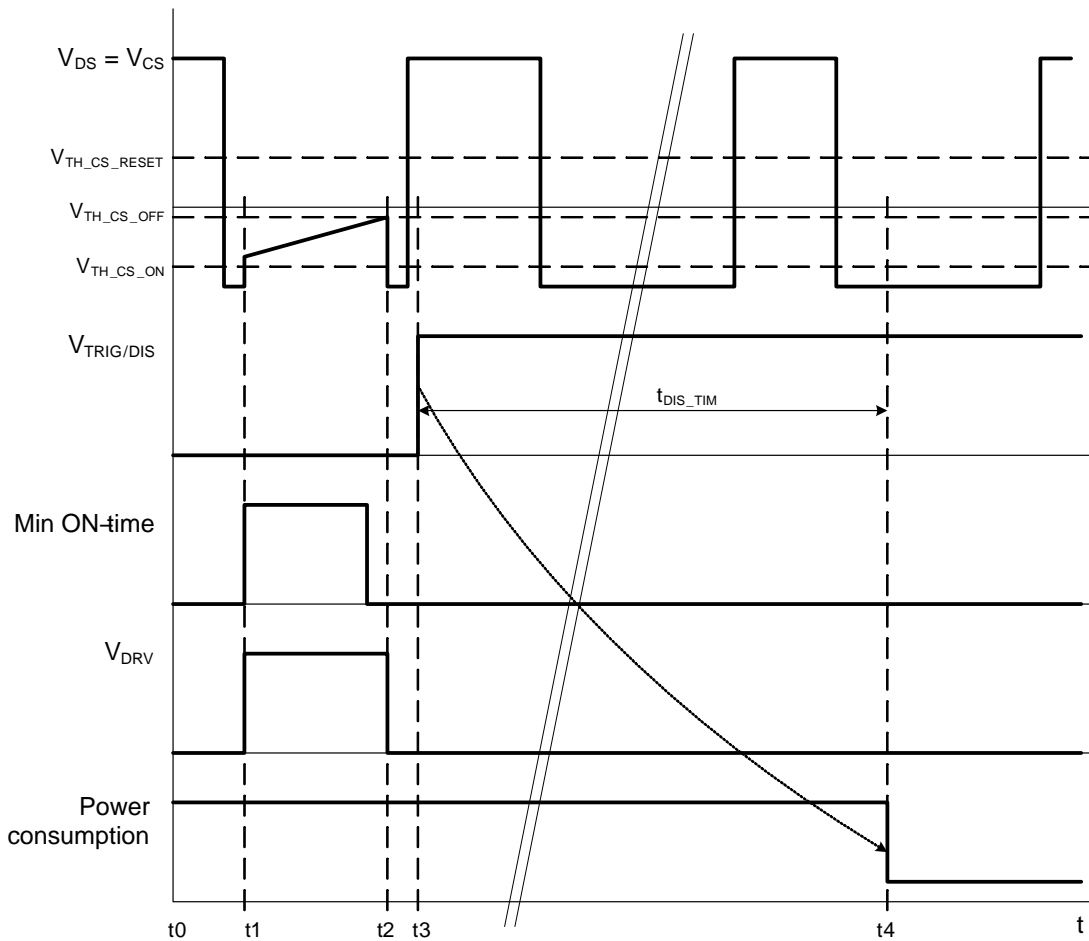

**Figure 57. Trigger Input Functionality Waveforms – Two Pulses at One Cycle**

Figure 57 shows IC behavior in case the trigger signal features two pulses during one cycle of the VDS (CS) signal. The trigger goes low enables the DRV just before time  $t_1$  and DRV turns-on because the VDS voltage drops under  $V_{TH\_CS\_ON}$  threshold voltage. The trigger signal disables driver at time  $t_2$ . The trigger drops down to LOW level in time  $t_3$ , but IC waits for complete minimum off-time. Minimum off-time execution is blocked until CS pin

voltage goes above  $V_{TH\_CS\_RESET}$  threshold. Next cycle starts in time  $t_6$ . The TRIG/DIS is low so driver is enabled and ready to be turned on when  $V_{DS}$  falls below  $V_{TH\_CS\_ON}$  threshold voltage thus the driver is turned on at time  $t_6$ . The trigger signal rises up to HIGH level at time  $t_7$ , consequently DRV turns-off and IC waits for high CS voltage to start minimum off-time execution.

# NCP4305



**Figure 58. Trigger Input Functionality Waveforms – Disable Mode Activation**

In Figure 58 above, at  $t_2$  the CS pin rises to  $V_{TH\_CS\_OFF}$  and the SR MOSFET is turned-off. At  $t_3$  the TRIG/DIS signal is held high for more than  $t_{DIS\_TIM}$ . NCP4305 enters disable mode after  $t_{DIS\_TIM}$ . Driver output is disabled in disable mode. The DRV stays low (disabled) during

transition to disable mode. Figure 59 shows disable mode transition 2nd case – i.e. when trigger rising edge comes during the trigger blank period. Figure 60 shows entering into disable mode and back to normal sequences.

# NCP4305

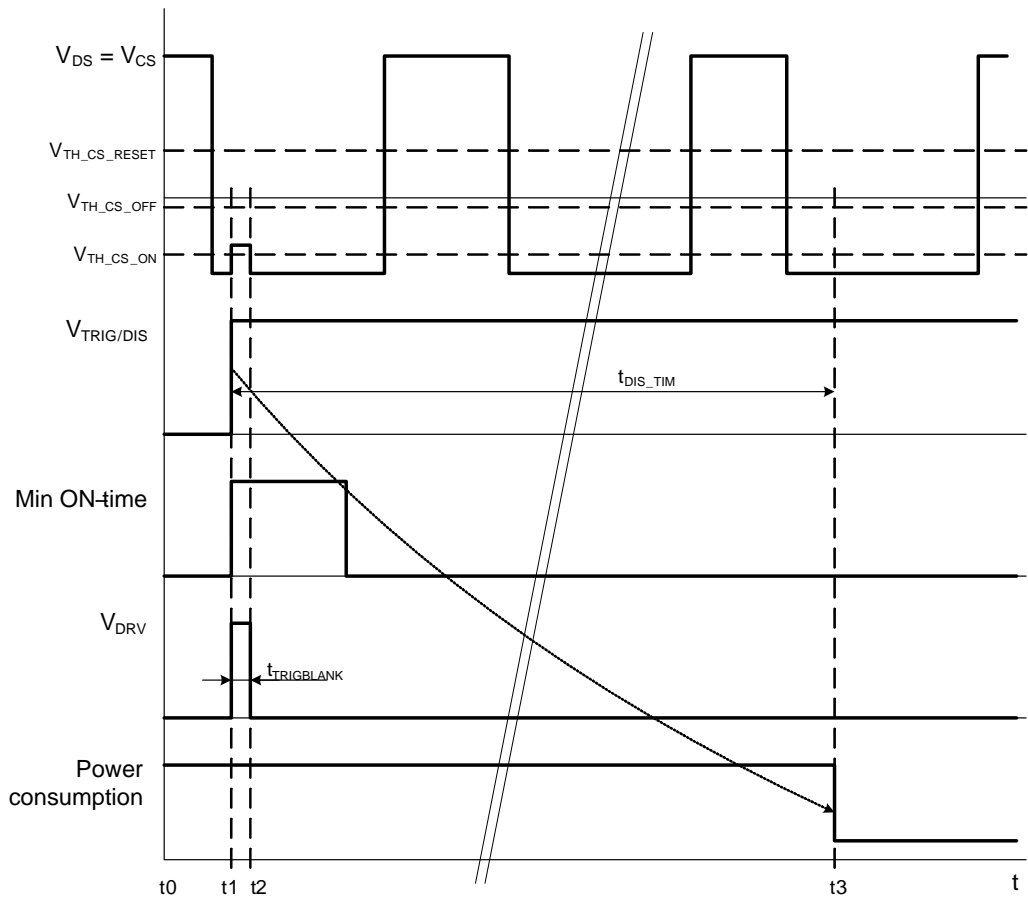

Figure 59. Trigger Input Functionality Waveforms – Disable Mode Clock Initiation

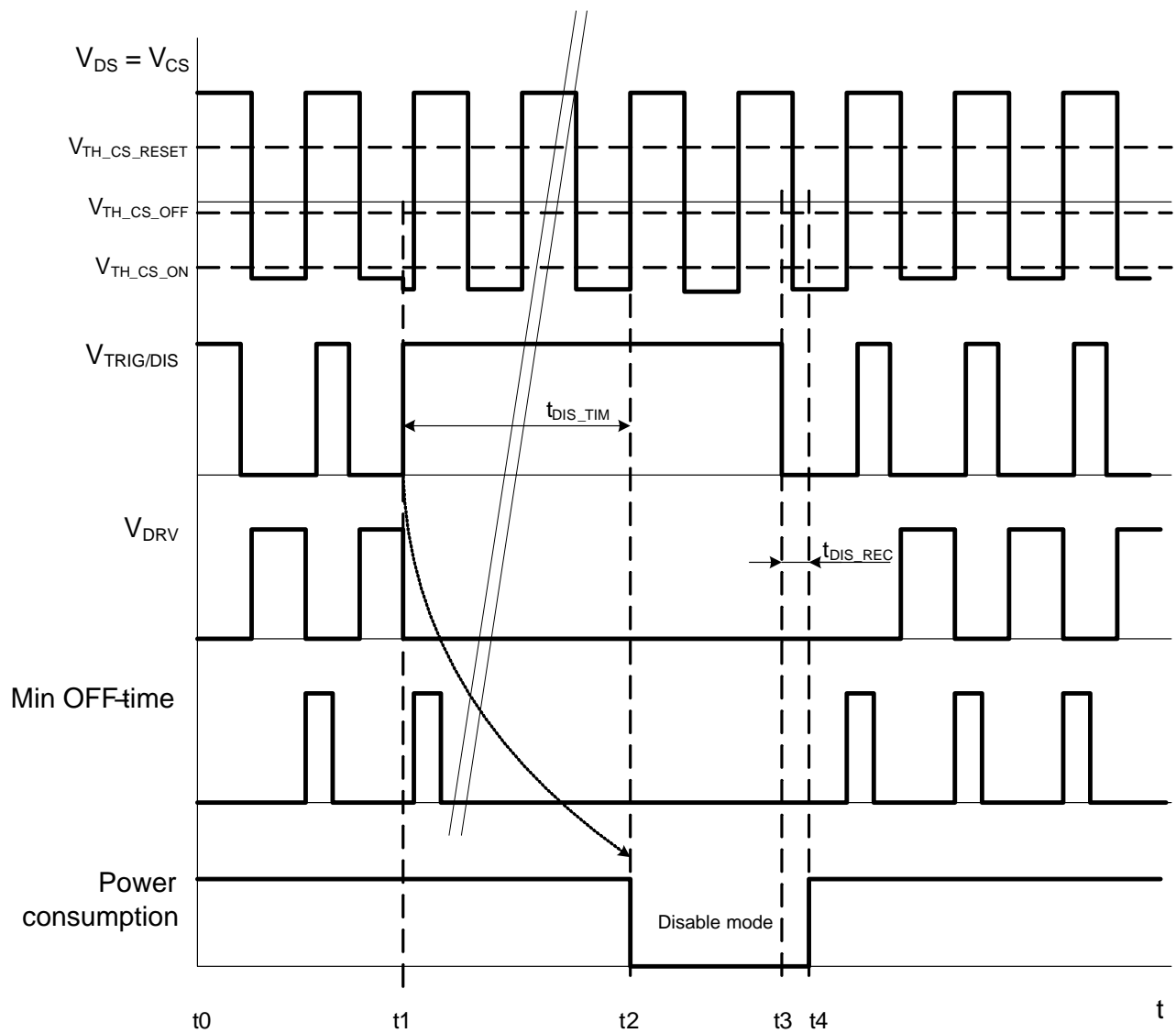

Figure 60. Trigger Input Functionality Waveforms – Disable and Normal Modes

Figures 61 and 62 shows exit from disable mode in detail. NCP4305 requires up to  $t_{DIS\_REC}$  to recover all internal circuitry to normal operation mode when recovering from disable mode. The driver is then enabled after complete  $t_{MIN\_TOFF}$  period when CS( $V_{DS}$ ) voltage is over  $V_{TH\_CS\_RESET}$  threshold. Driver turns-on in the next cycle

on CS ( $V_{DS}$ ) falling edge signal only ( $t_5$  – Figure 61). The DRV stays low during recovery time period. Trigger input has to be low at least for  $t_{DIS\_END}$  time to end disable mode and start with recovery. Trigger can go back high after  $t_{DIS\_END}$  without recovery interruption.



# NCP4305

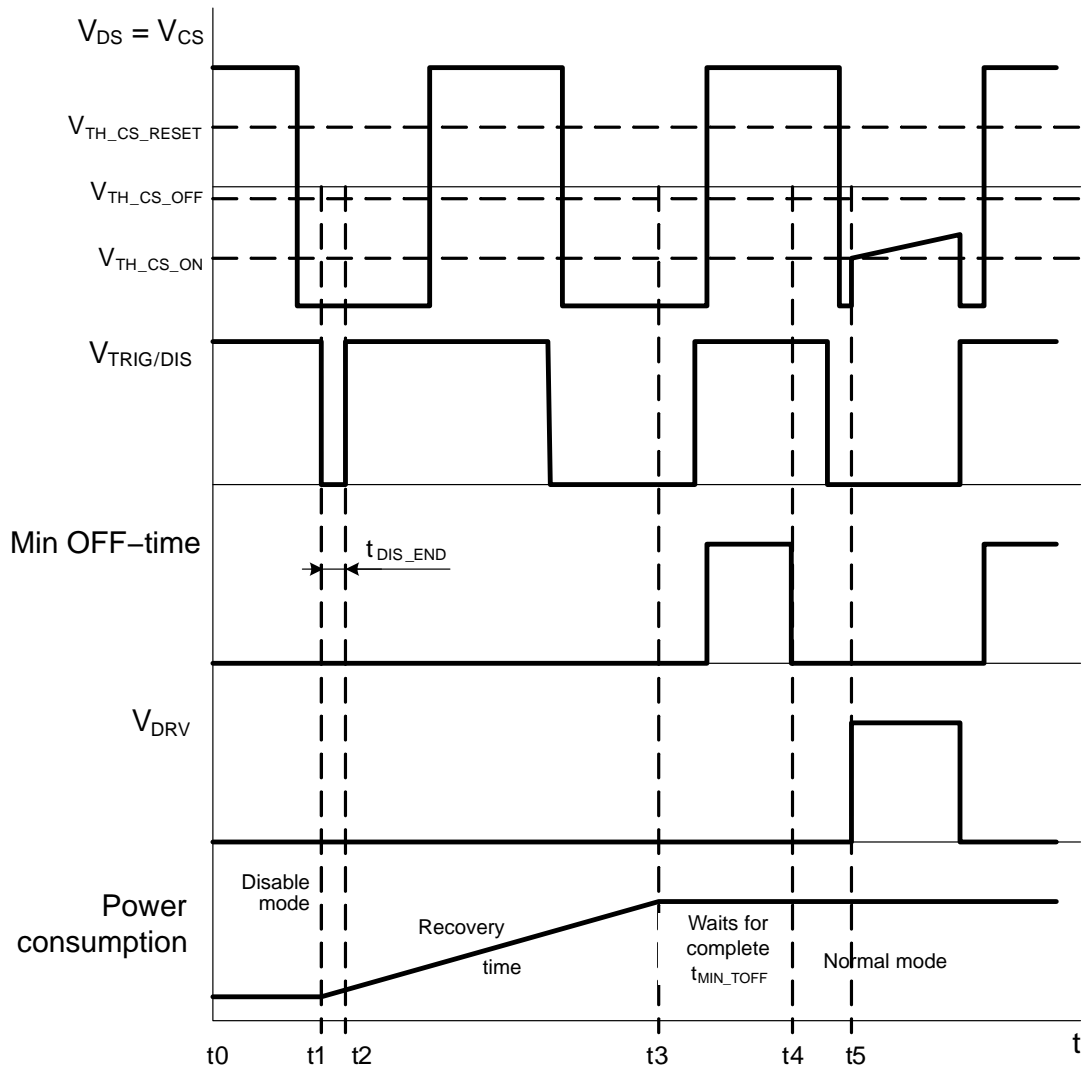

Figure 62. Trigger Input Functionality Waveforms



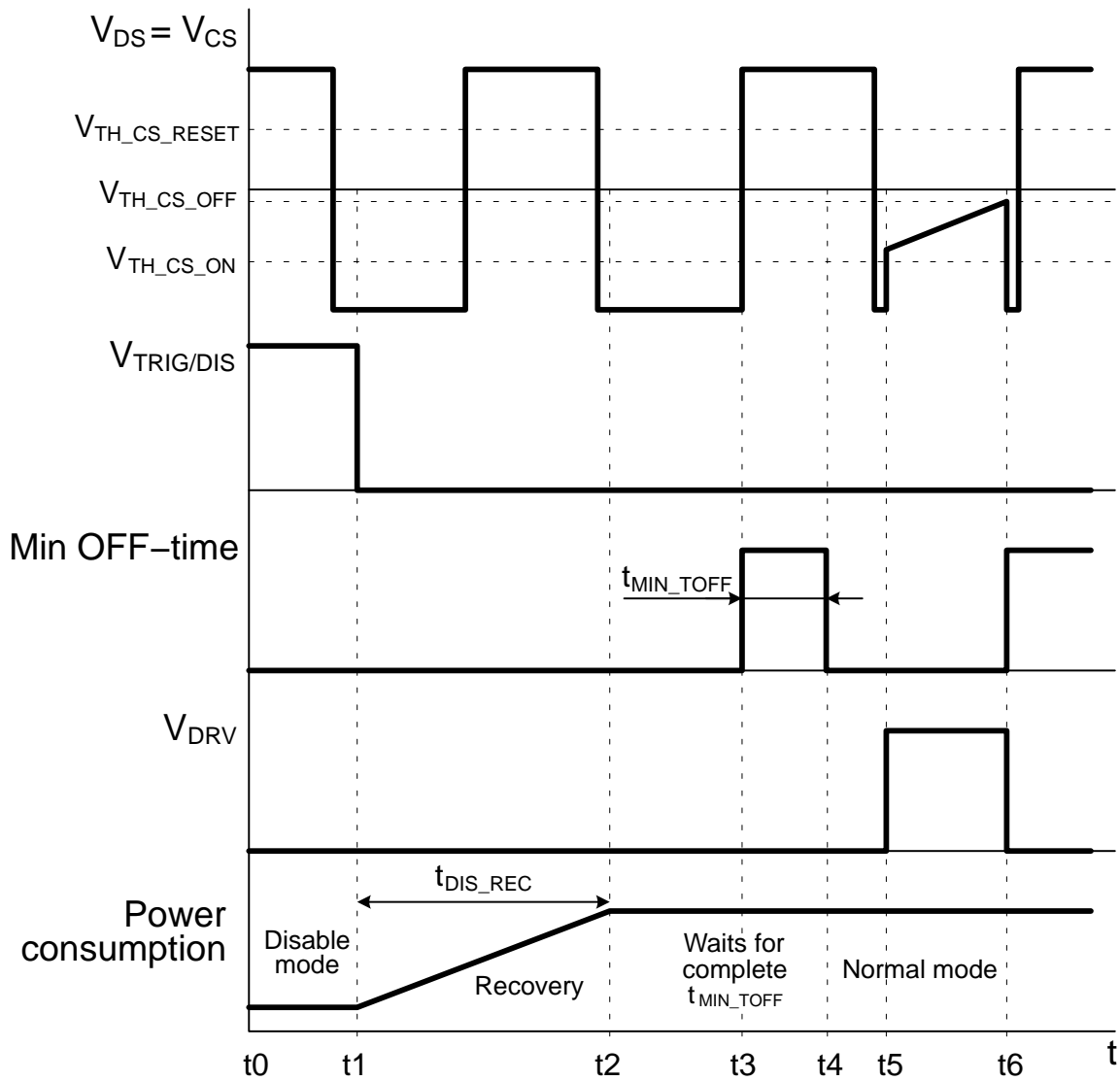

Figure 63. Trigger Input Functionality Waveforms

Figure 63 shows detail IC behavior after disable mode is ended. The trigger pin voltage goes low at  $t_1$  and after  $t_{DIS\_REC}$  IC leaves disable mode ( $t_2$ ).  $V_{DS}$  voltage goes high

again at time  $t_3$  and this event starts minimum off-time timer execution. Next  $V_{DS}$  falling edge below  $V_{TH\_CS\_ON}$  level activates driver.

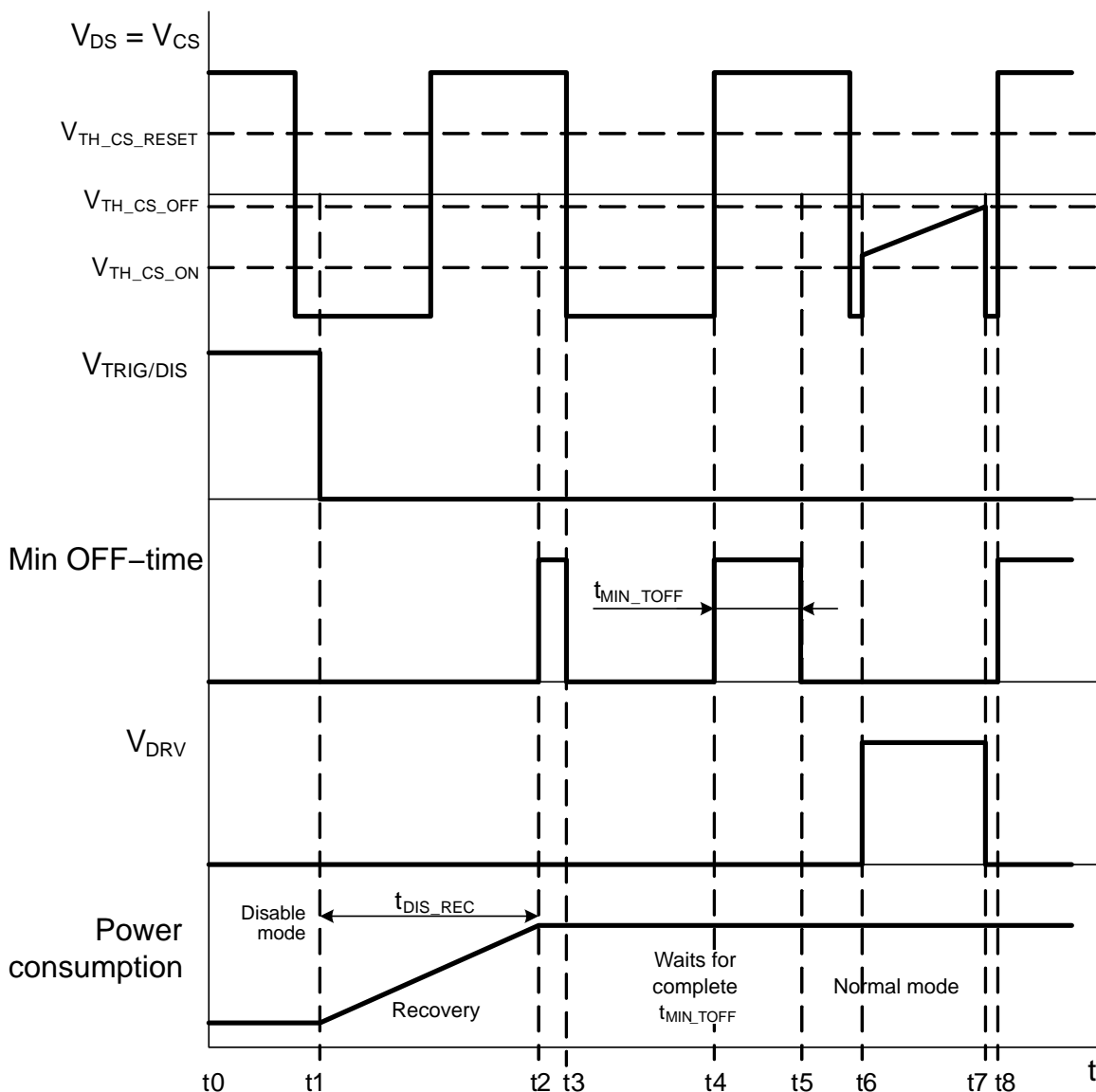
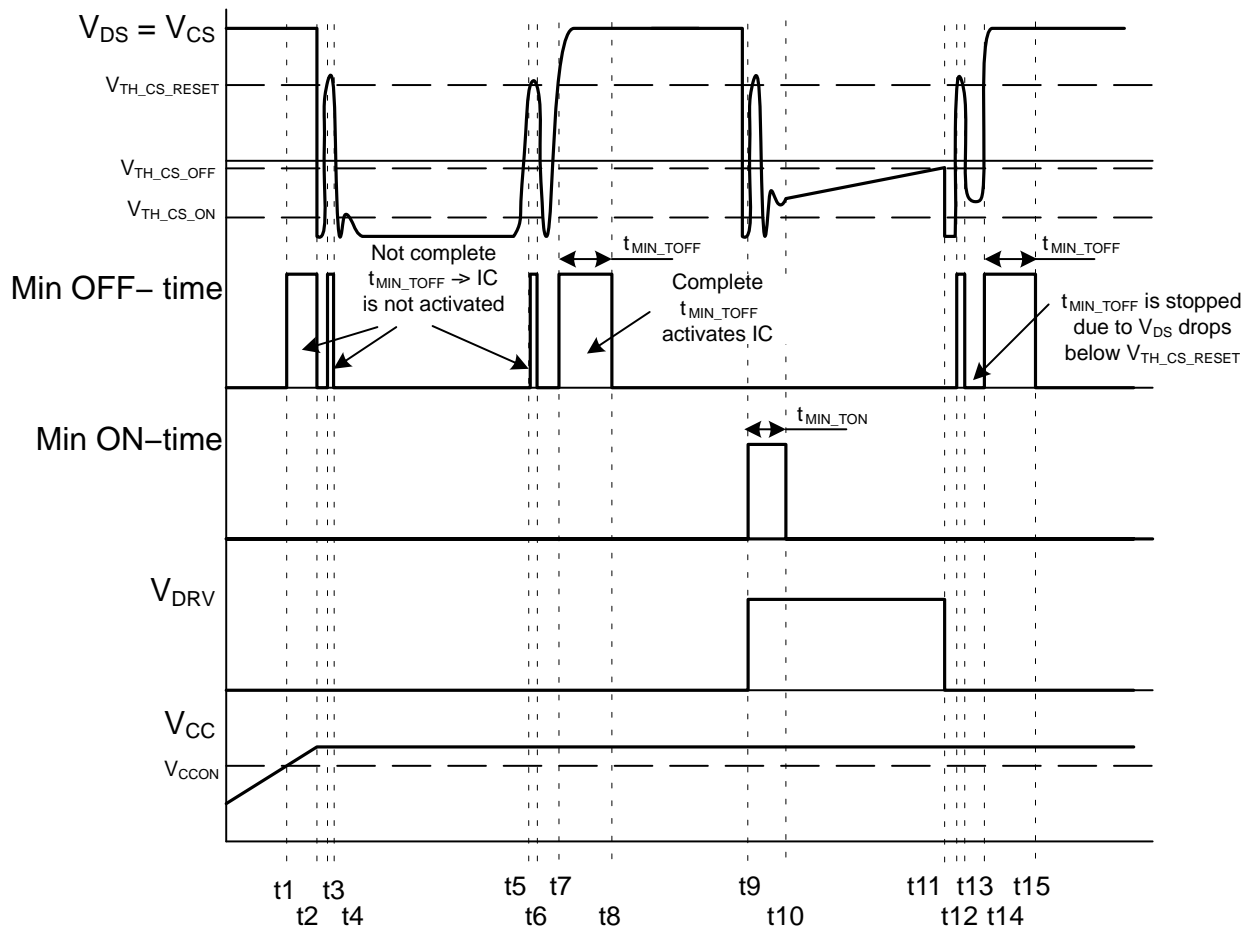

Figure 64. Trigger Input Functionality Waveforms

Different situation of leaving from disable mode is shown at Figure 64. Minimum off-time execution starts at time  $t_2$ , but before time elapses  $V_{DS}$  voltage falls to negative voltage. This interrupts minimum off-time execution and

the IC waits to another time when  $V_{DS}$  voltage is positive and then is again started the minimum off-time timer. The IC returns into normal mode after whole minimum off-time elapses.

## NCP4305



**Figure 65. NCP4305 Operation after Start-Up Event**

Start-up event waveforms are shown at Figure 65. A start-up event is very similar to an exit from disable mode event. The IC waits for a complete minimum off-time event (CS pin voltage is higher than  $V_{TH\_CS\_RESET}$ ) until drive pulses can continue. Figure 65 shows how the minimum off-time timer is reset when CS voltage is oscillating through  $V_{TH\_CS\_RESET}$  level. The NCP4305 starts operation at time  $t1$  (time  $t1$  can be seen as a wake-up event from the disable mode through TRIG/DIS or LLD pin). Internal logic waits for one complete minimum off-time period to expire before the NCP4305 can activate the driver after a start-up or wake-up event. The minimum off-time timer starts to run at time  $t1$ , because  $V_{CS}$  is higher than  $V_{TH\_CS\_RESET}$ . The timer is then reset, before its set

minimum off-time period expires, at time  $t2$  thanks to CS voltage lower than  $V_{TH\_CS\_RESET}$  threshold. The aforementioned reset situation can be seen again at time  $t3$ ,  $t4$ ,  $t5$  and  $t6$ . A complete minimum off-time period elapses between times  $t7$  and  $t8$  allowing the IC to activate a driver output after time  $t8$ .

The NCP4305 works very well in CCM application without any triggering method, but using some may improve overall operation. Typical application schematics of CCM flyback converters using two different primary triggering techniques can be seen in Figures 66 and 67. Both provided methods reduce the commutation losses and the SR MOSFET drain voltage spike, which results in improved efficiency.

## NCP4305

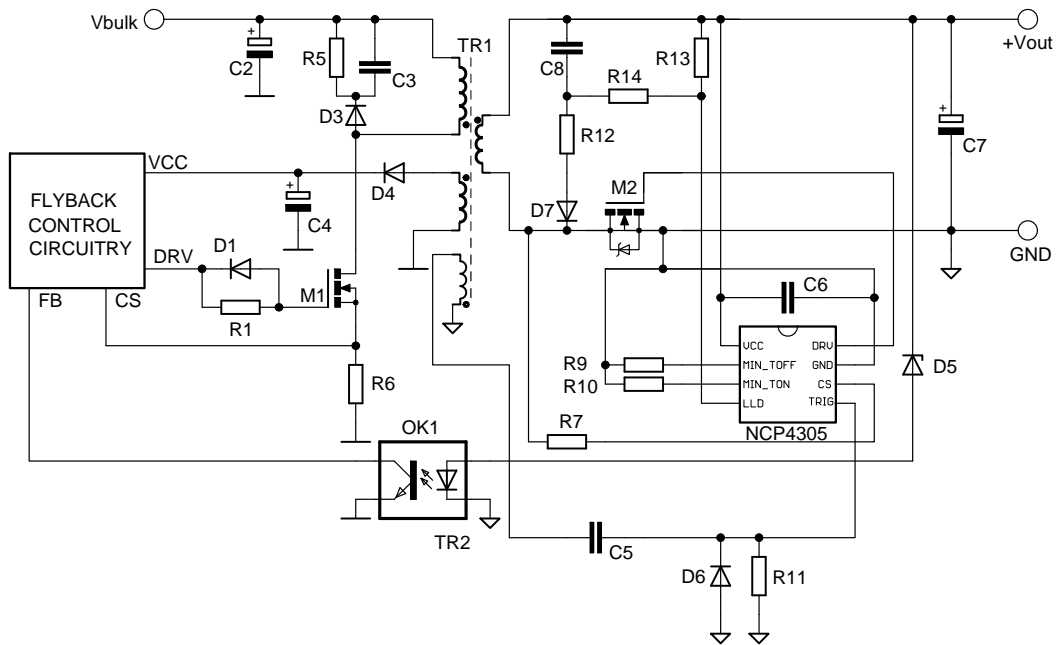

**Figure 66. Primary Triggering in Deep CCM Application Using Auxiliary Winding – NCP4305A, B, C or D**

The application shown in Figure 66 is simplest and the most cost effective solution for primary SR triggering. This method uses auxiliary winding made of triple insulated wire placed close to the primary winding section. This auxiliary winding provides information about primary turn-on event to the SR controller before the secondary winding reverses.

This is possible thanks to the leakage between primary and secondary windings that creates natural delay in energy transfer. This technique provides approximately 0.5% efficiency improvement when the application is operated in deep CCM and a transformer that has a leakage of 1% of primary inductance is used.

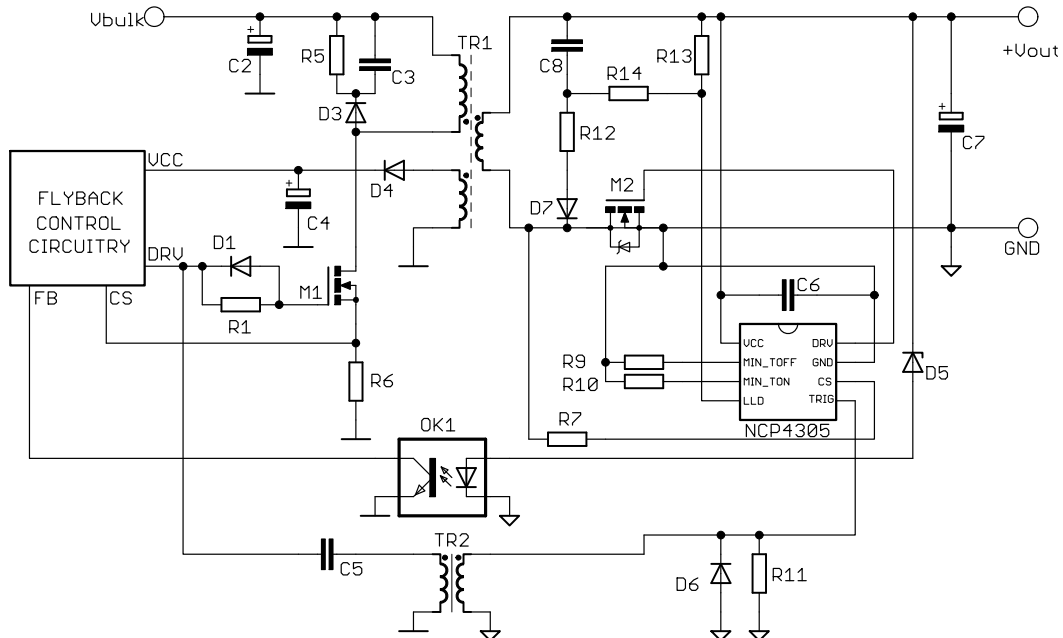

**Figure 67. Primary Triggering in Deep CCM Application Using Trigger Transformer – NCP4305A, B, C or D**

Application from Figure 67 uses an ultra-small trigger transformer to transfer primary turn-on information directly from the primary controller driver pin to the SR controller trigger input. Because the trigger input is rising edge

sensitive, it is not necessary to transmit the entire primary driver pulse to the secondary. The coupling capacitor C5 is used to allow the trigger transformer's core to reset and also to prepare a needle pulse (a pulse with width shorter than

100 ns) to be transmitted to the NCP4305 trigger input. The advantage of needle trigger pulse usage is that the required volt-second product of the pulse transformer is very low and that allows the designer to use very small and cheap magnetic. The trigger transformer can even be prepared on a small toroidal ferrite core with outer diameter of 4 mm and four turns for primary and secondary windings to assure  $L_{primary} = L_{secondary} > 10 \mu\text{H}$ . Proper safety insulation between primary and secondary sides can be easily assured by using triple insulated wire for one or, better, both windings.

This primary triggering technique provides approximately 0.5% efficiency improvement when the application is operated in deep CCM and transformer with leakage of 1% of primary inductance is used.

It is also possible to use capacitive coupling (use additional capacitor with safety insulation) between the

primary and secondary to transmit the trigger signal. We do not recommend this technique as the parasitic capacitive currents between primary and secondary may affect the trigger signal and thus overall system functionality.

**Minimum  $t_{ON}$  and  $t_{OFF}$  Adjustment**

The NCP4305 offers an adjustable minimum on-time and off-time blanking periods that ease the implementation of a synchronous rectification system in any SMPS topology. These timers avoid false triggering on the CS input after the MOSFET is turned on or off.

The adjustment of minimum  $t_{ON}$  and  $t_{OFF}$  periods are done based on an internal timing capacitance and external resistors connected to the GND pin – refer to Figure 68 for a better understanding.

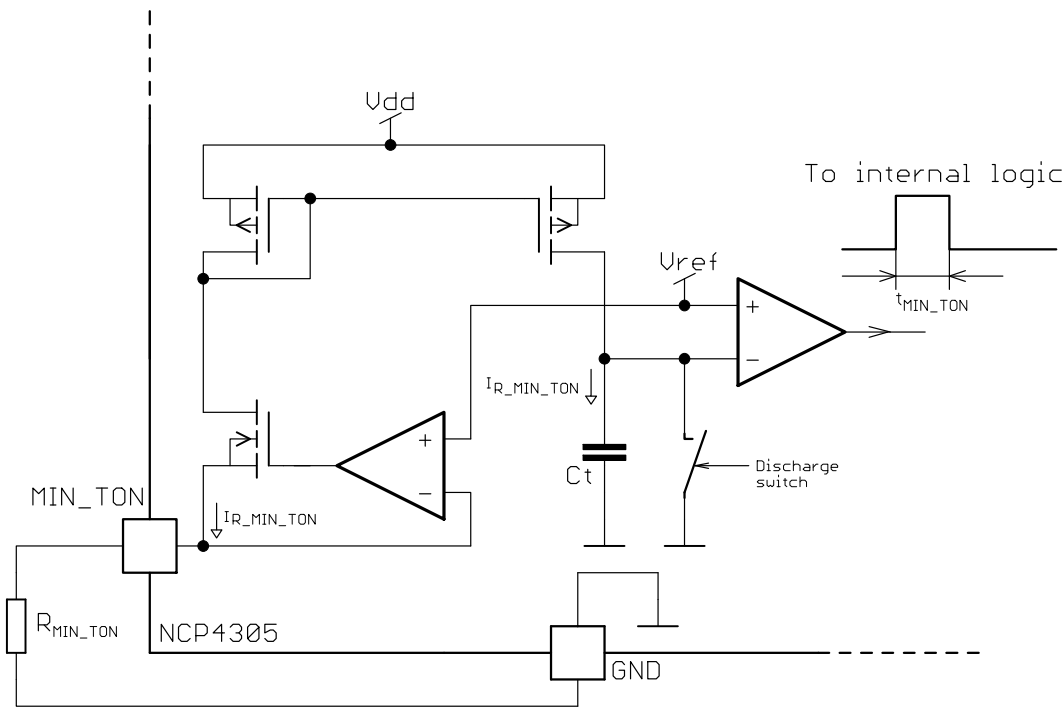

**Figure 68. Internal Connection of the MIN\_TON Generator (the MIN\_TOFF Works in the Same Way)**

Current through the MIN\_TON adjust resistor can be calculated as:

$$I_{R\_MIN\_TON} = \frac{V_{ref}}{R_{Ton\_min}} \quad (\text{eq. 5})$$

If the internal current mirror creates the same current through  $R_{MIN\_TON}$  as used the internal timing capacitor ( $C_t$ ) charging, then the minimum on-time duration can be calculated using this equation.

$$t_{MIN\_TON} = C_t \frac{V_{ref}}{I_{R\_MIN\_TON}} = C_t \frac{V_{ref}}{\frac{V_{ref}}{R_{MIN\_TON}}} = C_t \cdot R_{MIN\_TON} \quad (\text{eq. 6})$$

The internal capacitor size would be too large if  $I_{R\_MIN\_TON}$  was used. The internal current mirror uses a proportional current, given by the internal current mirror ratio. One can then calculate the MIN\_TON and MIN\_TOFF blanking periods using below equations:

$$t_{MIN\_TON} = 1.00 \cdot 10^{-4} \cdot R_{MIN\_TON} [\mu\text{s}] \quad (\text{eq. 7})$$

$$t_{MIN\_TOFF} = 1.00 \cdot 10^{-4} \cdot R_{MIN\_TOFF} [\mu\text{s}] \quad (\text{eq. 8})$$

Note that the internal timing comparator delay affects the accuracy of Equations 7 and 8 when MIN\_TON/MIN\_TOFF times are selected near to their minimum possible values. Please refer to Figures 69 and 70 for measured minimum on and off time charts.

# NCP4305

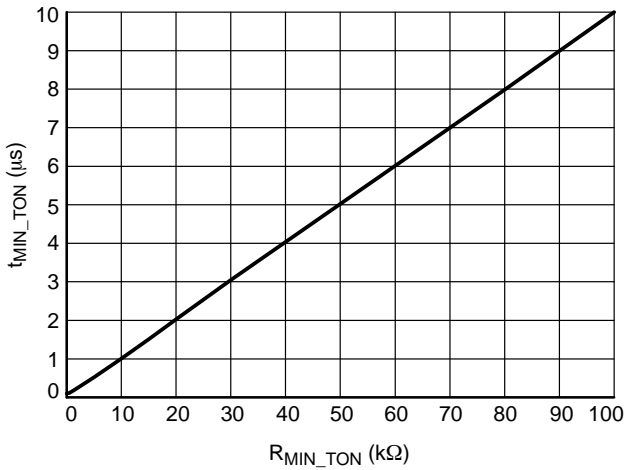

Figure 69. MIN\_TON Adjust Characteristics

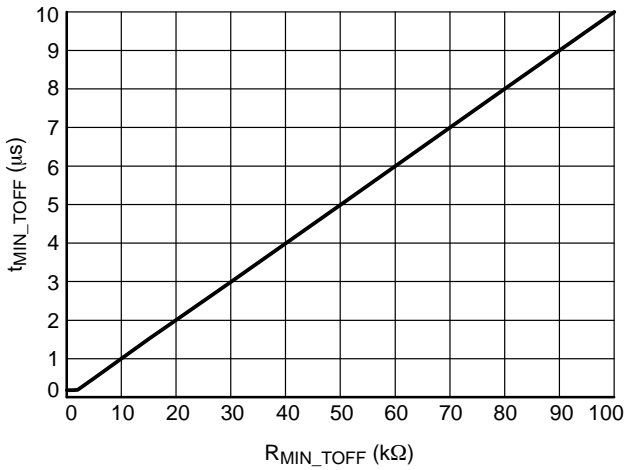

Figure 70. MIN\_TOFF Adjust Characteristics

The absolute minimum  $t_{ON}$  duration is internally clamped to 55 ns and minimum  $t_{OFF}$  duration to 245 ns in order to prevent any potential issues with the MIN\_TON and/or MIN\_TOFF pins being shorted to GND.

The NCP4305 features dedicated anti-ringing protection system that is implemented with a MIN\_TOFF blank generator. The minimum off-time one-shot generator is restarted in the case when the CS pin voltage crosses  $V_{TH\_CS\_RESET}$  threshold and MIN\_TOFF period is active. The total off-time blanking period is prolonged due to the ringing in the application (refer to Figure 45).

Some applications may require adaptive minimum on and off time blanking periods. With NCP4305 it is possible to modulate blanking periods by using an external NPN transistor – refer to Figure 71. The modulation signal can be derived based on the load current, feedback regulator voltage or other application parameter.

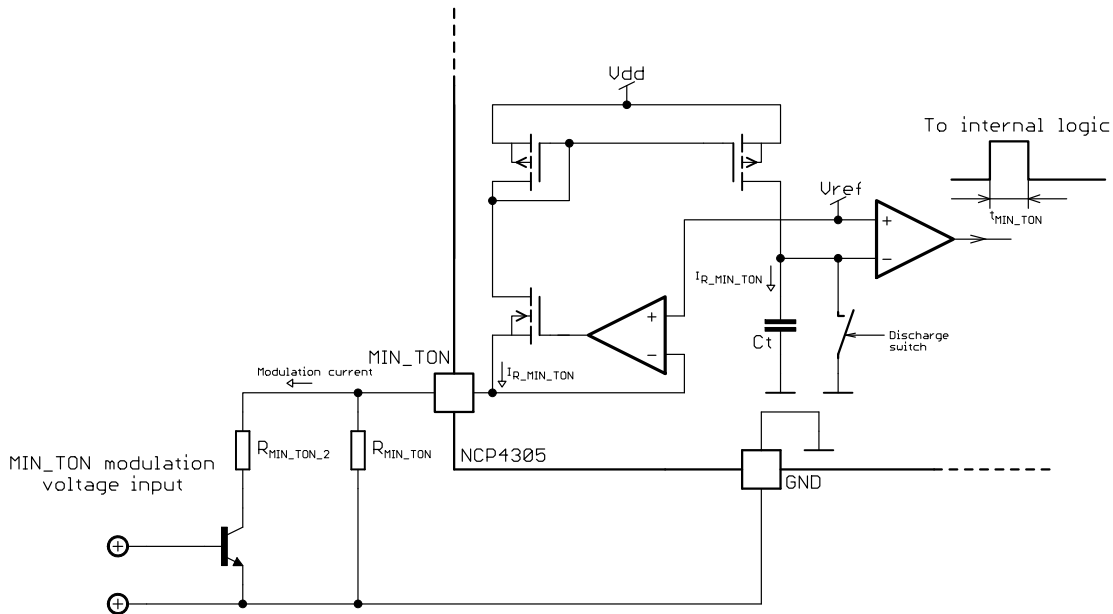

Figure 71. Possible Connection for MIN\_TON and MIN\_TOFF Modulation

**Maximum  $t_{ON}$  adjustment**

The NCP4305Q offers an adjustable maximum on-time (like the  $min_{t_{ON}}$  and  $min_{t_{OFF}}$  settings shown above) that can be very useful for QR controllers at high loads. Under high load conditions the QR controller can operate in CCM thanks to this feature. The NCP4305Q version has the ability to turn-off the DRV signal to the SR MOSFET before the secondary side current reaches zero. The DRV signal from the NCP4305Q can be fed to the primary side through a pulse transformer (see Figure 4 for detail) to a transistor on the primary side to emulate a ZCD event before an actual ZCD event occurs. This feature helps to keep the minimum switching frequency up so that there is better energy transfer through the transformer (a smaller transformer core can be used). Also another advantage is that the IC controls the SR MOSFET and turns off from secondary side before the primary side is turned on in CCM to ensure no cross conduction. By controlling the SR MOSFET's turn off before the primary side turn off, producing a zero cross conduction operation, this will improve efficiency.

The Internal connection of the MAX\_TON feature is shown in Figure 72. Figure 72 shows a method that allows for a modification of the maximum on-time according to output voltage. At a lower  $V_{OUT}$ , caused by hard overload or at startup, the maximum on-time should be longer than at nominal voltage. Resistor  $R_A$  can be used to modulate maximum on-time according to  $V_{OUT}$  or any other parameter.

The operational waveforms at heavy load in QR type SMPS are shown in Figure 73. After  $t_{MAX\_TON}$  time is exceeded, the synchronous switch is turned off and the secondary current is conducted by the diode. Information about turned off SR MOSFET is transferred by the DRV pin through a small pulse transformer to the primary side where it acts on the ZCD detection circuit to allow the primary switch to be turned on. Secondary side current disappears before the primary switch is turned on without a possibility of cross current condition.

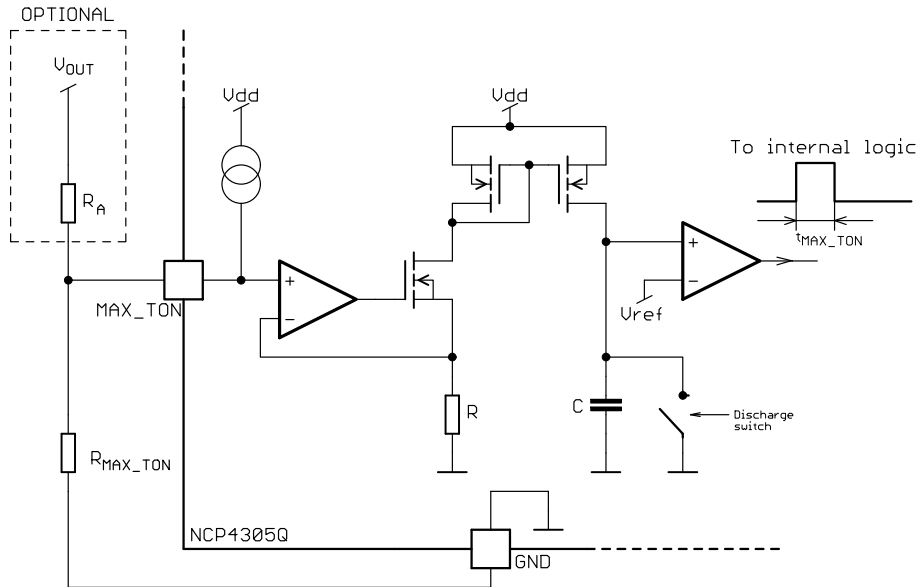

**Figure 72. Internal Connection of the MAX\_TON Generator, NCP4305Q**

# NCP4305

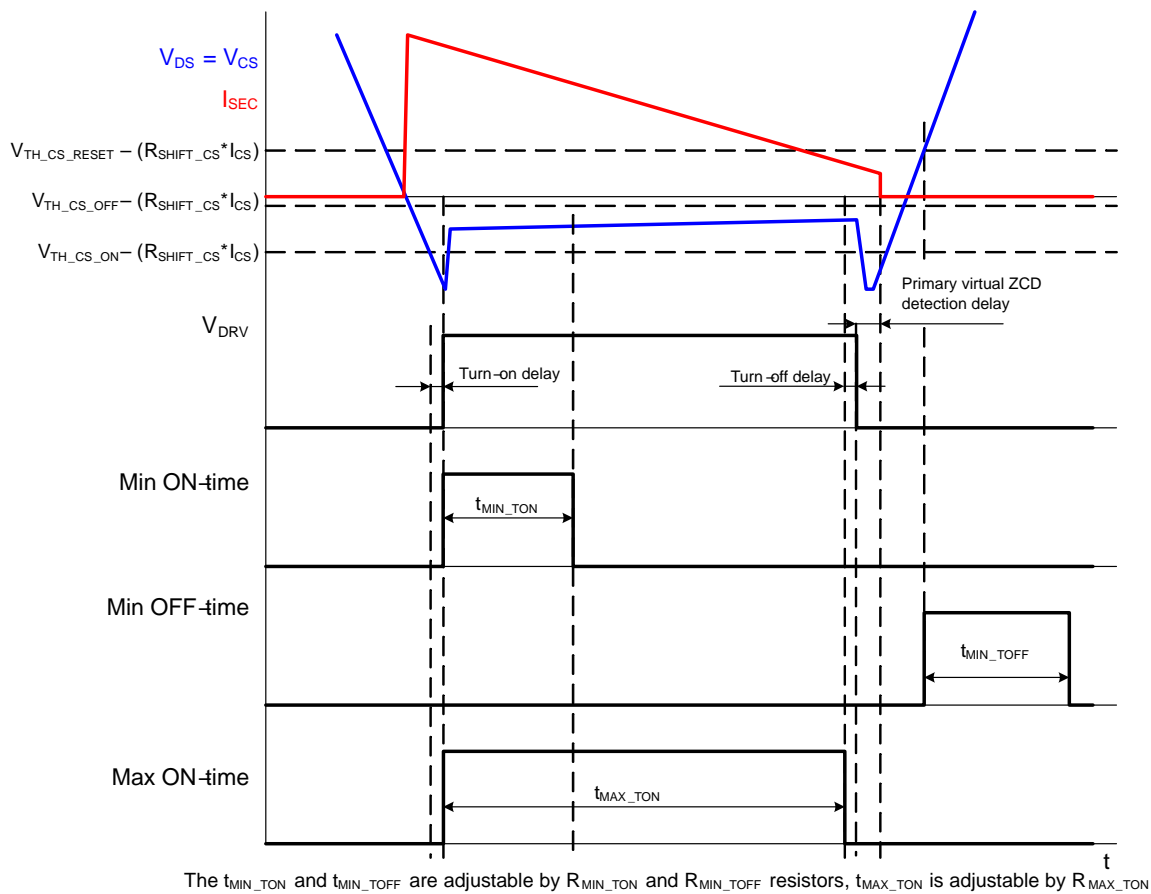

**Figure 73. Function of MAX\_TON Generator in Heavy Load Condition**

## Adaptive Gate Driver Clamp and automatic Light Load Turn-off

As synchronous rectification system significantly improves efficiency in most of SMPS applications during medium or full load conditions. However, as the load reduces into light or no-load conditions the SR MOSFET driving losses and SR controller consumption become more critical. The NCP4305 offers two key features that help to optimize application efficiency under light load and no load conditions:

1<sup>st</sup> – The driver clamp voltage is modulated and follows the output load condition. When the output load decreases the driver clamp voltage decreases as well. Under heavy load conditions the SR MOSFET’s gate needs to be driven very hard to optimize the performance and reduce conduction losses. During light load conditions it is not as critical to drive the SR MOSFET’s channel into such a low  $R_{DS(on)}$  state. This adaptive gate clamp technique helps to optimize efficiency during light load conditions especially in LLC applications where the SR MOSFETs with high input capacitance are used.

Driver voltage modulation improves the system behavior when SR controller state is changed in and out of normal or disable modes. Soft transient between drop at body diode

and drop at MOSFET’s  $R_{DS(on)}$  only improves stability during load transients.

2<sup>nd</sup> – In extremely low load conditions or no load conditions the NCP4305 fully disables driver output and reduces the internal power consumption when output load drops below the level where skip-mode takes place.

Both features are controlled by voltage at LLD pin. The LLD pin voltage characteristic is shown in Figure 74. Driver voltage clamp is a linear function of the voltage difference between the VCC and LLD pins from  $V_{LLD\_REC}$  point up to  $V_{LLD\_MAX}$ . A disable mode is available, where the IC current consumption is dramatically reduced, when the difference of  $V_{CC} - V_{LLD}$  voltage drops below  $V_{LLD\_DIS}$ . When the voltage difference between the  $V_{CC} - V_{LLD}$  pins increase above  $V_{LLC\_REC}$  the disable mode ends and the IC regains normal operation. It should be noted that there are also some time delays to enter and exit from the disable mode. Time waveforms are shown at Figure 75. There is a time,  $t_{LLD\_DISH}$ , that the logic ignores changes from disable mode to normal or reversely. There is also some time  $t_{LLD\_DIS\_R}$  that is needed after an exit from the disable mode to assure proper internal block biasing before SR controller starts work normally.



# NCP4305

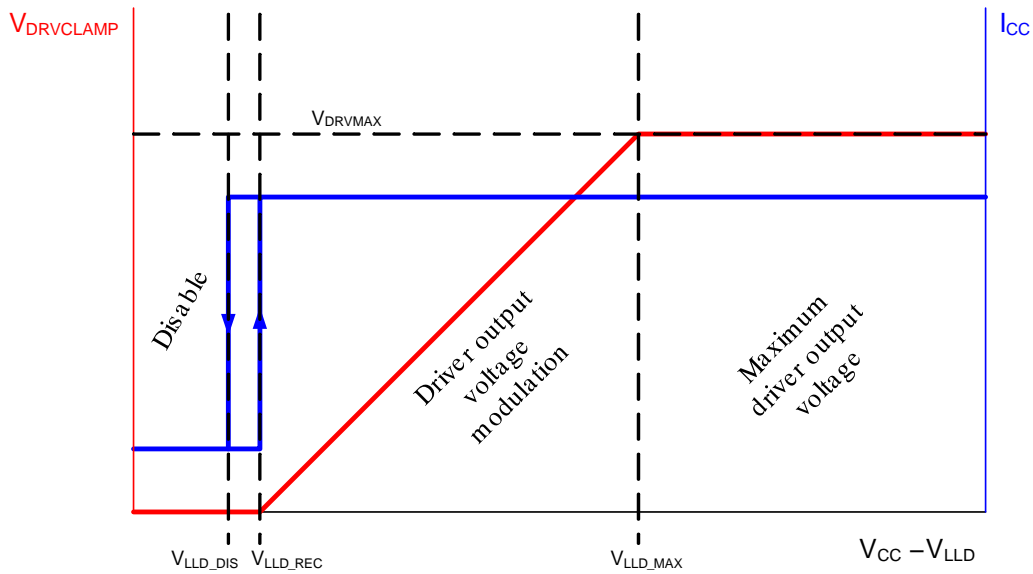

Figure 74. LLD Voltage to Driver Clamp and Current Consumption Characteristic (DRV Unloaded)

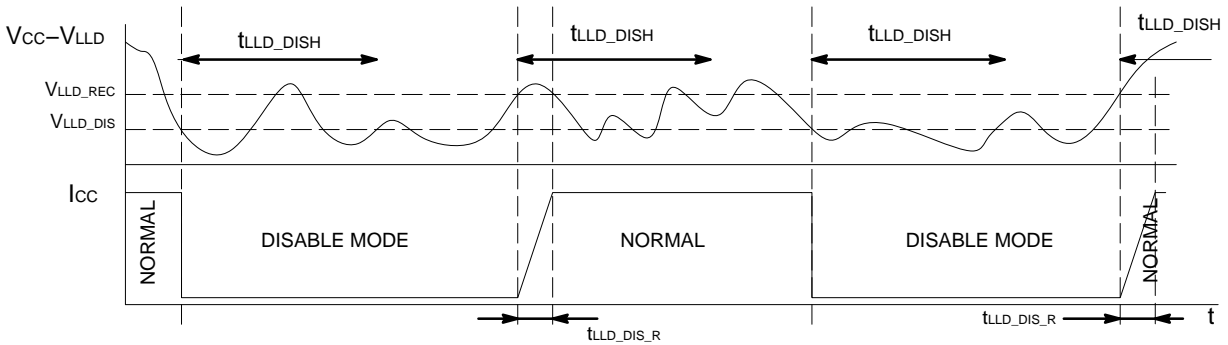

Figure 75. LLD Pin Disable Behavior in Time Domain

The two main SMPS applications that are using synchronous rectification systems today are flyback and LLC topologies. Different light load detection techniques are used in NCP4305 controller to reflect differences in operation of both mentioned applications.

Detail of the light load detection implementation technique used in NCP4305 in flyback topologies is displayed at Figure 76. Using a simple and cost effective peak detector implemented with a diode D1, resistors R1

through R3 and capacitors C2 and C3, the load level can be sensed. Output voltage of this detector on the LLD pin is referenced to controller VCC with an internal differential amplifier in NCP4305. The output of the differential amplifier is then used in two places. First the output is used in the driver block for gate drive clamp voltage adjustment. Next, the output signal is evaluated by a no-load detection comparator that activates IC disable mode in case the load is disconnected from the application output.

## NCP4305

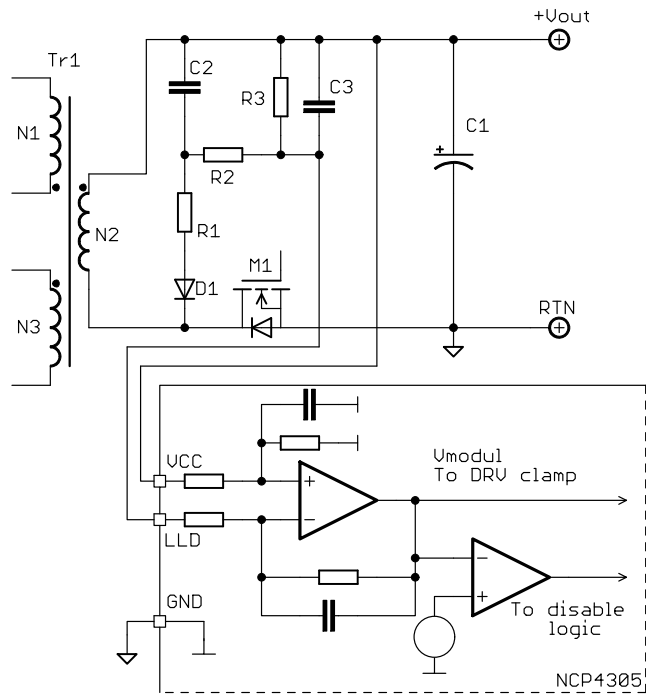

**Figure 76. NCP4305 Light Load and No Load Detection Principle in Flyback Topologies**

Operational waveforms related to the flyback LLD circuitry are provided in Figure 77. The SR MOSFET drain voltage drops to  $\sim 0$  V when  $I_{SEC}$  current is flowing. When the SR MOSFET is conducting the capacitor C2 charges-up, causing the difference between the LLD pin and VCC pin to increase, and drop the LLD pin voltage. As the load decreases the secondary side currents flows for a shorter a shorter time. C2 has less time to accumulate charge and the voltage on the C2 decreases, because it is discharged by R2 and R3. This smaller voltage on C2 will cause the LLD pin voltage to increase towards  $V_{CC}$  and the difference between LLD and  $V_{CC}$  will go to zero. The output voltage then

directly reduces DRV clamp voltage down from its maximum level. The DRV is then fully disabled when IC enters disable mode. The IC exits from disable mode when difference between LLD voltage and  $V_{CC}$  increases over  $V_{LLD\_REC}$ . Resistors R2 and R3 are also used for voltage level adjustment and with capacitor C3 form low pass filter that filters relatively high speed ripple at C2. This low pass filter also reduces speed of state change of the SR controller from normal to disable mode or reversely. Time constant should be higher than feedback loop time constant to keep whole system stable.

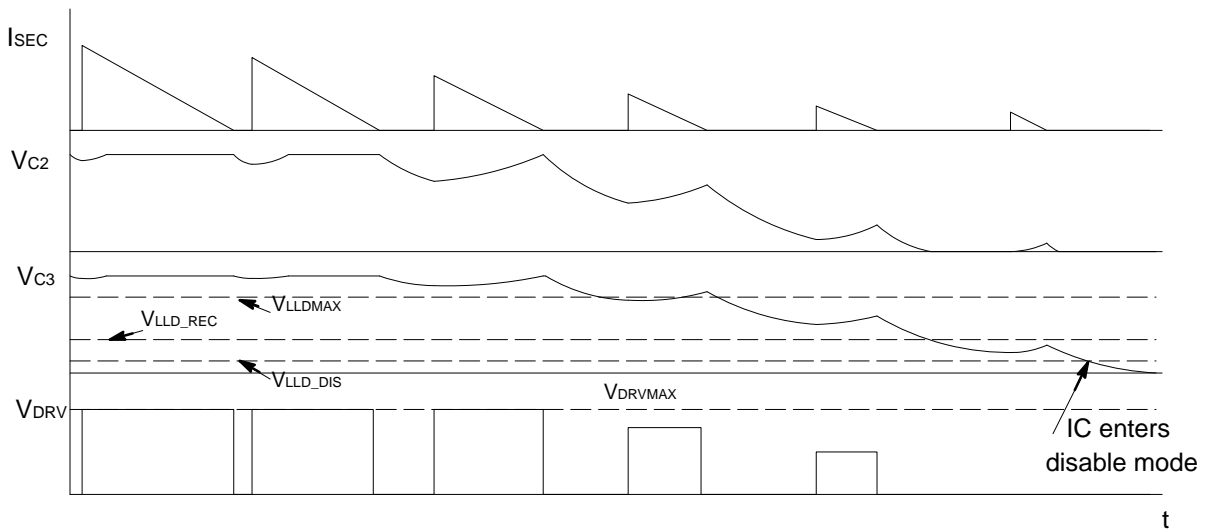

**Figure 77. NCP4305 Driver Clamp Modulation Waveforms in Flyback Application Entering into Light/No Load Condition**



# NCP4305

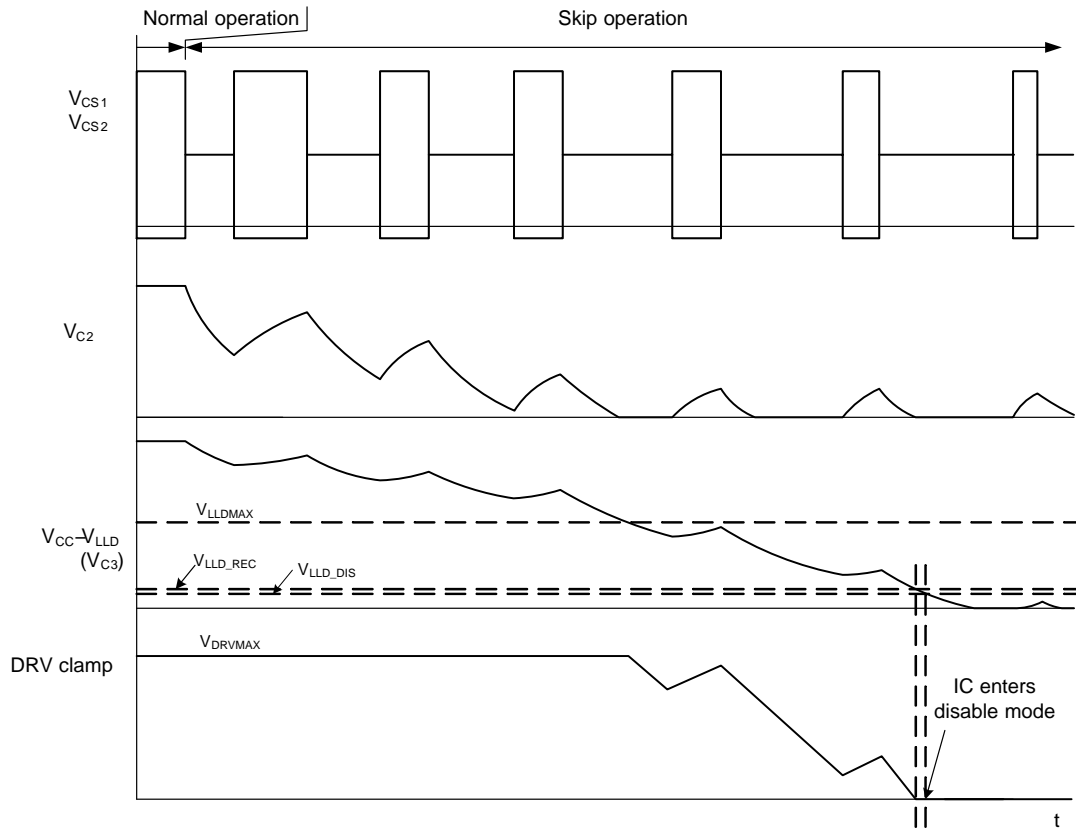
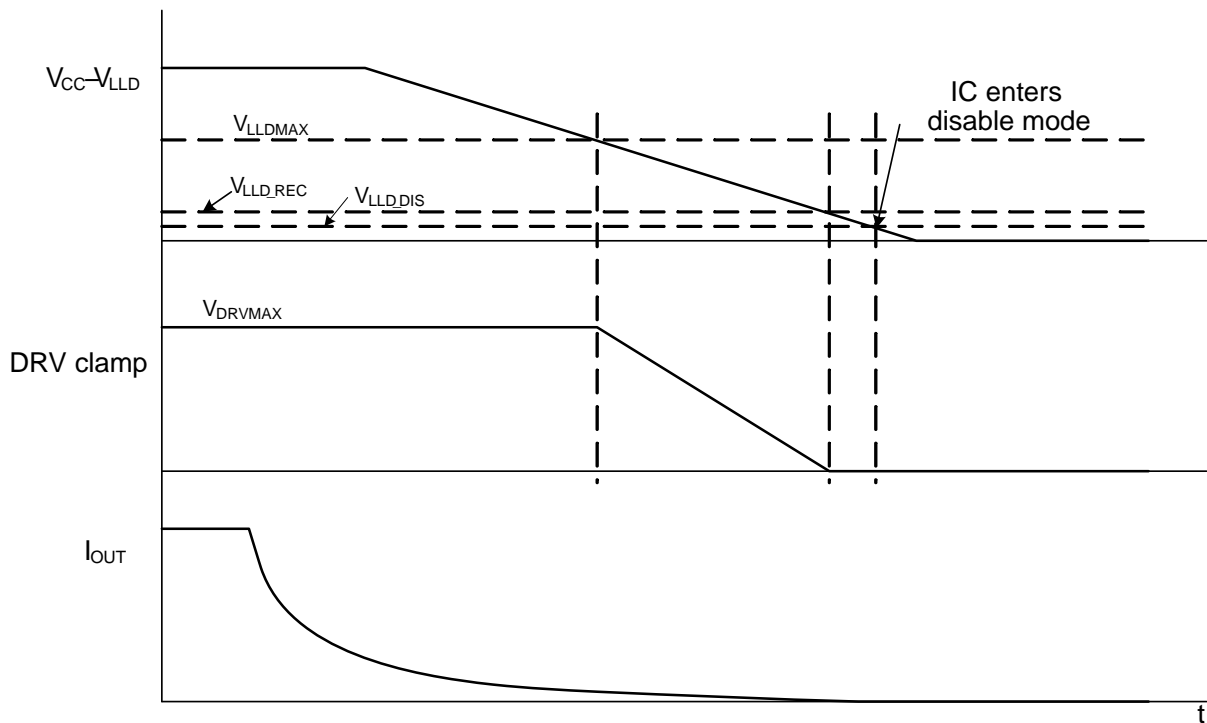

Figure 80. NCP4305 Driver Clamp Modulation Waveforms in LLC Application

# NCP4305



**Figure 81. NCP4305 Driver Clamp Modulation Circuitry Characteristic in LLC Application**

There exist some LLC applications where behavior described above is not the best choice. These applications transfer significant portion of energy in a few first pulses in skip burst. It is good to keep SR fully working during skip mode to improve efficiency. There can be still saved some energy using LLD function by activation disable mode between skip bursts. Simplified schematic for this LLD

behavior is shown in Figure 46. Operation waveforms for this option are provided in Figure 83. Capacitor C2 is charged to maximum voltage when LLC is switching. When there is no switching in skip, capacitor C2 is discharged by R2 and when LLD voltage referenced to VCC falls below  $V_{LLD\_DIS}$  IC enters disable mode. Disable mode is ended when LLC starts switching.

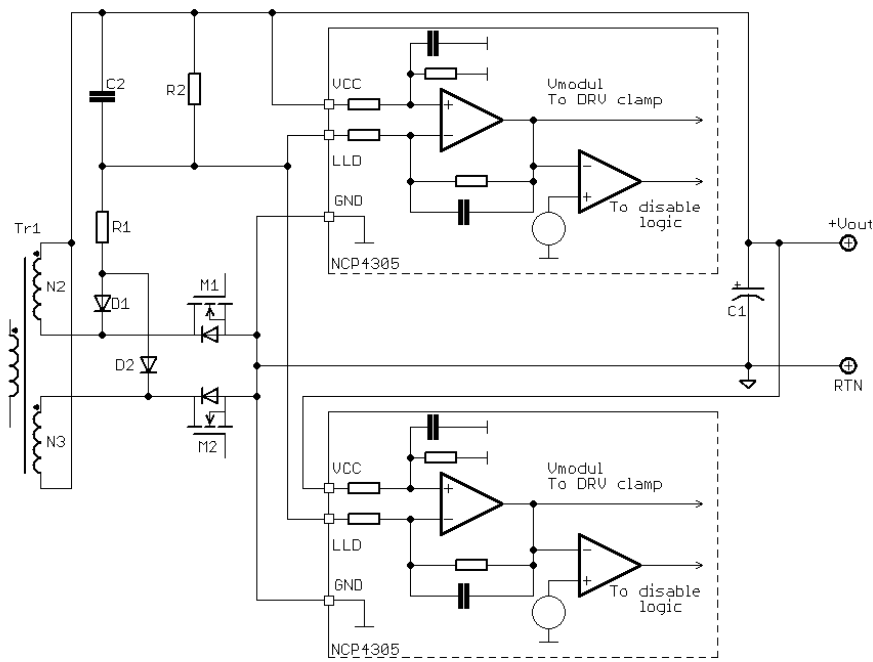

**Figure 82. NCP4305 Light Load Detection in LLC Application – Other Option**

# NCP4305

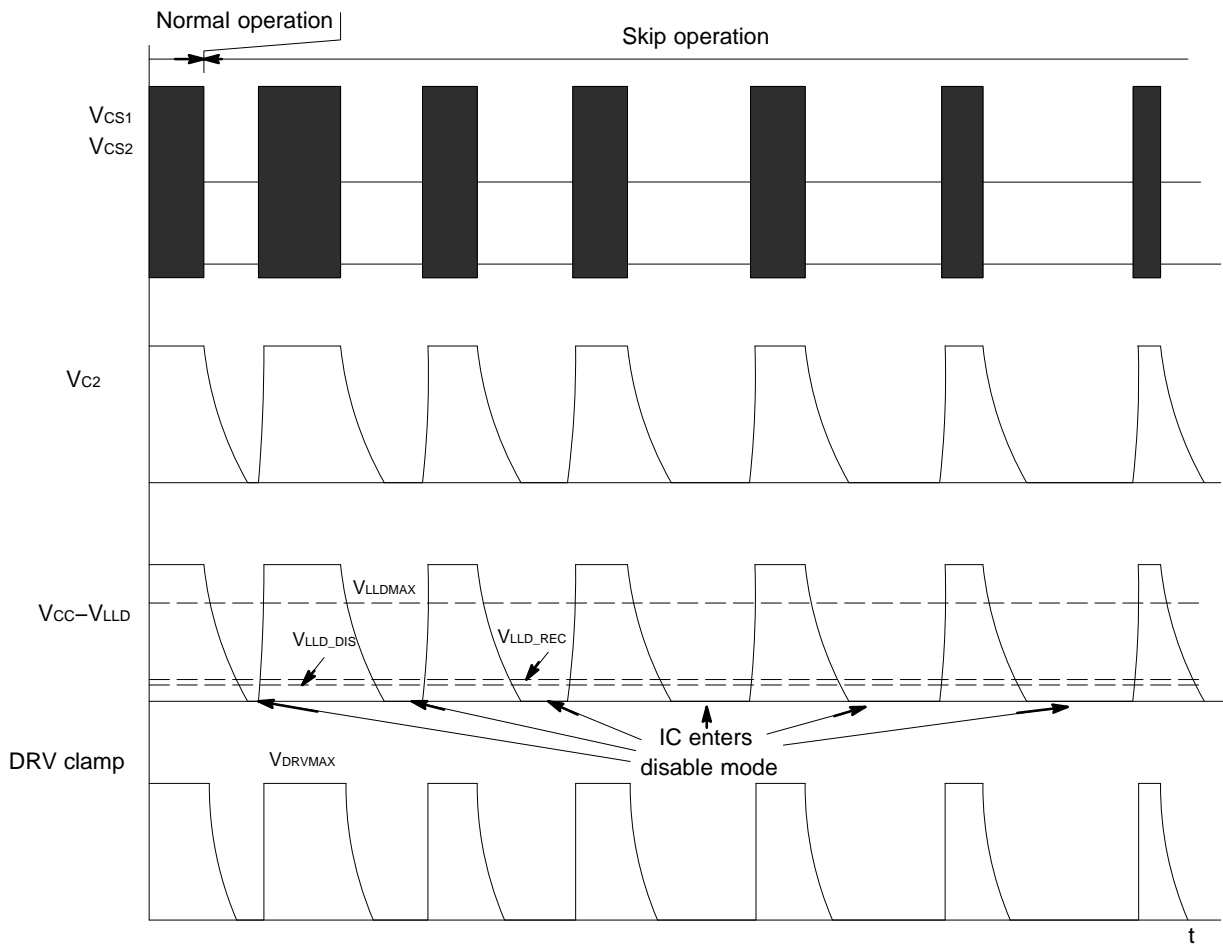

Figure 83. NCP4305 Light Load Detection Behavior in LLC Application – Other Option

## Power Dissipation Calculation

It is important to consider the power dissipation in the MOSFET driver of a SR system. If no external gate resistor is used and the internal gate resistance of the MOSFET is very low, nearly all energy losses related to gate charge are dissipated in the driver. Thus it is necessary to check the SR driver power losses in the target application to avoid over temperature and to optimize efficiency.

In SR systems the body diode of the SR MOSFET starts conducting before SR MOSFET is turned-on, because there is some delay from  $V_{TH\_CS\_ON}$  detect to turn-on the driver. On the other hand, the SR MOSFET turn off process always starts before the drain to source voltage rises up

significantly. Therefore, the MOSFET switch always operates under Zero Voltage Switching (ZVS) conditions when in a synchronous rectification system.

The following steps show how to approximately calculate the power dissipation and DIE temperature of the NCP4305 controller. Note that real results can vary due to the effects of the PCB layout on the thermal resistance.

### Step 1 – MOSFET Gate-to Source Capacitance:

During ZVS operation the gate to drain capacitance does not have a Miller effect like in hard switching systems because the drain to source voltage does not change (or its change is negligible).

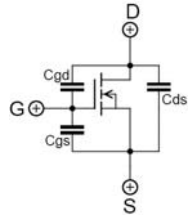
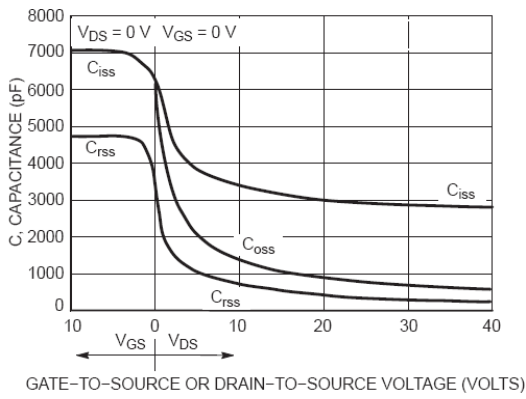

$$C_{iss} = C_{gs} + C_{gd}$$

$$C_{rss} = C_{gd}$$

$$C_{oss} = C_{ds} + C_{gd}$$

**Figure 84. Typical MOSFET Capacitances Dependency on  $V_{DS}$  and  $V_{GS}$  Voltages**

Therefore, the input capacitance of a MOSFET operating in ZVS mode is given by the parallel combination of the gate to source and gate to drain capacitances (i.e.  $C_{iss}$  capacitance for given gate to source voltage). The total gate charge,  $Q_{g\_total}$ , of most MOSFETs on the market is defined for hard switching conditions. In order to accurately calculate the driving losses in a SR system, it is necessary to determine the gate charge of the MOSFET for operation specifically in a ZVS system. Some manufacturers define this parameter as  $Q_{g\_ZVS}$ . Unfortunately, most datasheets do not provide this data. If the  $C_{iss}$  (or  $Q_{g\_ZVS}$ ) parameter is not available then

it will need to be measured. Please note that the input capacitance is not linear (as shown Figure 84) and it needs to be characterized for a given gate voltage clamp level.

**Step 2 – Gate Drive Losses Calculation:**

Gate drive losses are affected by the gate driver clamp voltage. Gate driver clamp voltage selection depends on the type of MOSFET used (threshold voltage versus channel resistance). The total power losses (driving losses and conduction losses) should be considered when selecting the gate driver clamp voltage. Most of today’s MOSFETs for SR systems feature low  $R_{DS(on)}$  for 5 V  $V_{GS}$  voltage. The NCP4305 offers both a 5 V gate clamp and a 10 V gate clamp for those MOSFET that require higher gate to source voltage.

The total driving loss can be calculated using the selected gate driver clamp voltage and the input capacitance of the MOSFET:

$$P_{DRV\_total} = V_{CC} \cdot V_{CLAMP} \cdot C_{g\_ZVS} \cdot f_{SW} \text{ (eq. 9)}$$

Where:

- $V_{CC}$  is the NCP4305 supply voltage
- $V_{CLAMP}$  is the driver clamp voltage
- $C_{g\_ZVS}$  is the gate to source capacitance of the MOSFET in ZVS mode
- $f_{sw}$  is the switching frequency of the target application

The total driving power loss won’t only be dissipated in the IC, but also in external resistances like the external gate resistor (if used) and the MOSFET internal gate resistance (Figure 50). Because NCP4305 features a clamped driver, it’s high side portion can be modeled as a regular driver switch with equivalent resistance and a series voltage source. The low side driver switch resistance does not drop immediately at turn-off, thus it is necessary to use an equivalent value ( $R_{DRV\_SIN\_EQ}$ ) for calculations. This method simplifies power losses calculations and still provides acceptable accuracy. Internal driver power dissipation can then be calculated using Equation 10:

# NCP4305

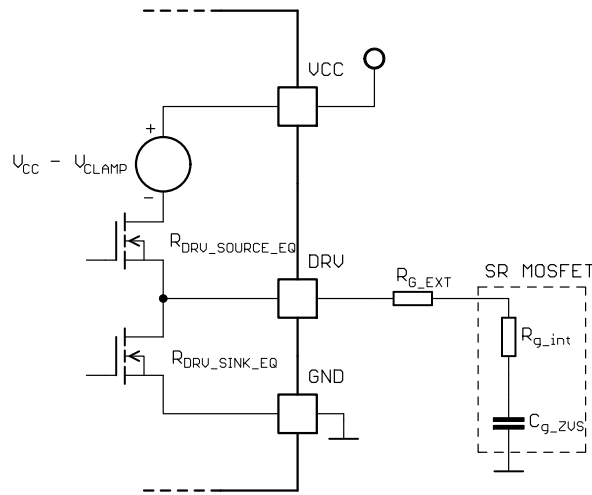

**Figure 85. Equivalent Schematic of Gate Drive Circuitry**

$$P_{DRV\_IC} = \frac{1}{2} \cdot C_{g\_ZVS} \cdot V_{CLAMP}^2 \cdot f_{SW} \cdot \left( \frac{R_{DRV\_SINK\_EQ}}{R_{DRV\_SINK\_EQ} + R_{G\_EXT} + R_{g\_int}} \right) + C_{g\_ZVS} \cdot V_{CLAMP} \cdot f_{SW} \cdot (V_{CC} - V_{CLAMP})$$

(eq. 10)

$$+ \frac{1}{2} \cdot C_{g\_ZVS} \cdot V_{CLAMP}^2 \cdot f_{SW} \cdot \left( \frac{R_{DRV\_SOURCE\_EQ}}{R_{DRV\_SOURCE\_EQ} + R_{G\_EXT} + R_{g\_int}} \right)$$

Where:

- $R_{DRV\_SINK\_EQ}$  is the NCP4305x driver low side switch equivalent resistance (0.5  $\Omega$ )
- $R_{DRV\_SOURCE\_EQ}$  is the NCP4305x driver high side switch equivalent resistance (1.2  $\Omega$ )
- $R_{G\_EXT}$  is the external gate resistor (if used)
- $R_{g\_int}$  is the internal gate resistance of the MOSFET

### Step 3 – IC Consumption Calculation:

In this step, power dissipation related to the internal IC consumption is calculated. This power loss is given by the  $I_{CC}$  current and the IC supply voltage. The  $I_{CC}$  current depends on switching frequency and also on the selected min  $t_{ON}$  and  $t_{OFF}$  periods because there is current flowing out from the min  $t_{ON}$  and  $t_{OFF}$  pins. The most accurate method for calculating these losses is to measure the  $I_{CC}$  current when  $C_{DRV} = 0$  nF and the IC is switching at the target frequency with given MIN\_TON and MIN\_TOFF adjust resistors. IC consumption losses can be calculated as:

$$P_{CC} = V_{CC} \cdot I_{CC} \quad (\text{eq. 11})$$

### Step 4 – IC Die Temperature Arise Calculation:

The die temperature can be calculated now that the total internal power losses have been determined (driver losses plus internal IC consumption losses). The package thermal resistance is specified in the maximum ratings table for a 35  $\mu\text{m}$  thin copper layer with no extra copper plates on any pin (i.e. just 0.5 mm trace to each pin with standard soldering points are used).

The DIE temperature is calculated as:

$$T_{DIE} = (P_{DRV\_IC} + P_{CC}) \cdot R_{\theta J-A} + T_A \quad (\text{eq. 12})$$

Where:

- $P_{DRV\_IC}$  is the IC driver internal power dissipation
- $P_{CC}$  is the IC control internal power dissipation
- $R_{\theta JA}$  is the thermal resistance from junction to ambient
- $T_A$  is the ambient temperature



# NCP4305

## PRODUCT OPTIONS

OPN	Package	UVLO [V]	DRV clamp [V]	Pin 5 function	Usage
NCP4305ADR2G	SOIC8	4.5	4.7	TRIG	LLC, CCM flyback, DCM flyback, forward, QR, QR with primary side CCM control
NCP4305AMTTWG	WDFN8	4.5	4.7	TRIG	
NCP4305DDR2G	SOIC8	4.5	9.5	TRIG	
NCP4305DMNTWG	DFN8	4.5	9.5	TRIG	
NCP4305DMTTWG	WDFN8	4.5	9.5	TRIG	
NCP4305QDR2G	SOIC8	4.5	9.5	MAX_TON	QR with forced CCM from secondary side

## ORDERING INFORMATION

Device	Package	Package marking	Packing	Shipping <sup>†</sup>
NCP4305ADR2G	SOIC8	NCP4305A	SOIC-8 (Pb-Free)	2500 /Tape & Reel
NCP4305DDR2G		NCP4305D		
NCP4305QDR2G		NCP4305Q		
NCP4305AMTTWG	WDFN8	5A	WDFN-8 (Pb-Free)	3000 /Tape & Reel
NCP4305DMTTWG		5D		
NCP4305DMNTWG	DFN8	4305D	DFN-8 (Pb-Free)	4000 /Tape & Reel

<sup>†</sup>For information on tape and reel specifications, including part orientation and tape sizes, please refer to our Tape and Reel Packaging Specifications Brochure, BRD8011/D.

# NCP4305

## PACKAGE DIMENSIONS

SOIC-8 NB  
CASE 751-07  
ISSUE AK

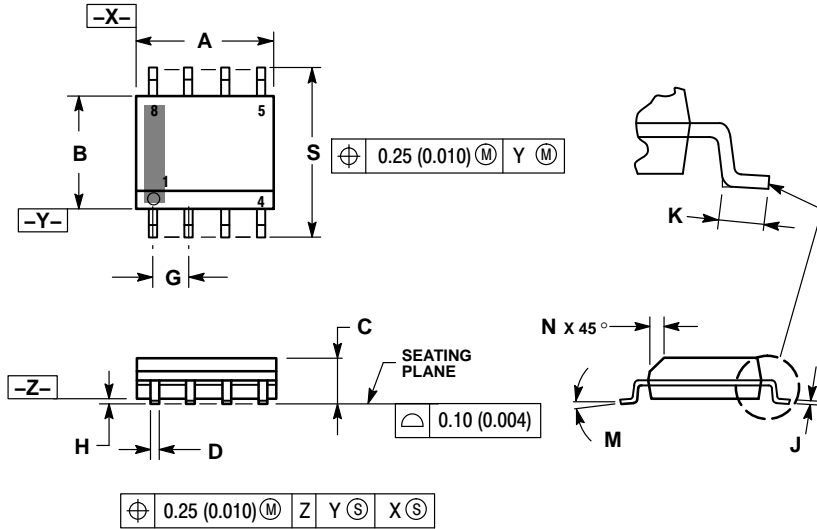

**NOTES:**

1. DIMENSIONING AND TOLERANCING PER ANSI Y14.5M, 1982.
2. CONTROLLING DIMENSION: MILLIMETER.
3. DIMENSION A AND B DO NOT INCLUDE MOLD PROTRUSION.
4. MAXIMUM MOLD PROTRUSION 0.15 (0.006) PER SIDE.
5. DIMENSION D DOES NOT INCLUDE DAMBAR PROTRUSION. ALLOWABLE DAMBAR PROTRUSION SHALL BE 0.127 (0.005) TOTAL IN EXCESS OF THE D DIMENSION AT MAXIMUM MATERIAL CONDITION.
6. 751-01 THRU 751-06 ARE OBSOLETE. NEW STANDARD IS 751-07.

DIM	MILLIMETERS		INCHES	
	MIN	MAX	MIN	MAX
A	4.80	5.00	0.189	0.197
B	3.80	4.00	0.150	0.157
C	1.35	1.75	0.053	0.069
D	0.33	0.51	0.013	0.020
G	1.27 BSC		0.050 BSC	
H	0.10	0.25	0.004	0.010
J	0.19	0.25	0.007	0.010
K	0.40	1.27	0.016	0.050
M	0° - 8°		0° - 8°	
N	0.25	0.50	0.010	0.020
S	5.80	6.20	0.228	0.244

### SOLDERING FOOTPRINT\*

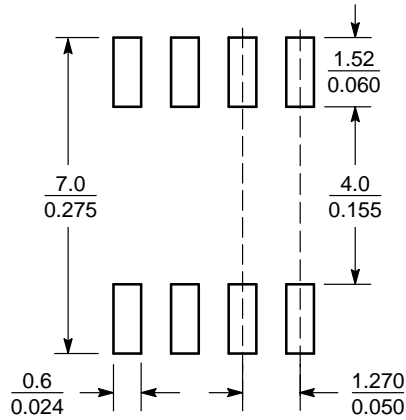

SCALE 6:1 ( $\frac{\text{mm}}{\text{inches}}$ )

\*For additional information on our Pb-Free strategy and soldering details, please download the ON Semiconductor Soldering and Mounting Techniques Reference Manual, SOLDERRM/D.

# NCP4305

## PACKAGE DIMENSIONS

DFN8 4x4  
CASE 488AF  
ISSUE C

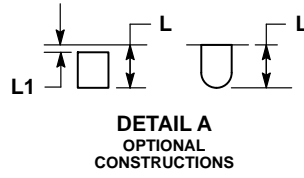
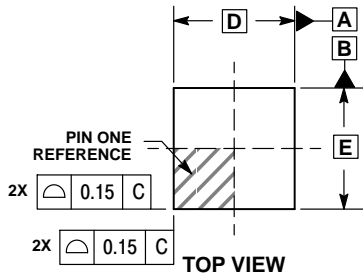

- NOTES:
1. DIMENSIONS AND TOLERANCING PER ASME Y14.5M, 1994.
  2. CONTROLLING DIMENSION: MILLIMETERS.
  3. DIMENSION b APPLIES TO PLATED TERMINAL AND IS MEASURED BETWEEN 0.15 AND 0.30MM FROM TERMINAL TIP.
  4. COPLANARITY APPLIES TO THE EXPOSED PAD AS WELL AS THE TERMINALS.
  5. DETAILS A AND B SHOW OPTIONAL CONSTRUCTIONS FOR TERMINALS.

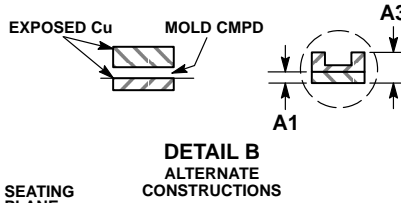
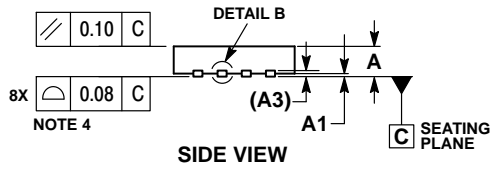

MILLIMETERS		
DIM	MIN	MAX
A	0.80	1.00
A1	0.00	0.05
A3	0.20	REF
b	0.25	0.35
D	4.00	BSC
D2	1.91	2.21
E	4.00	BSC
E2	2.09	2.39
e	0.80	BSC
K	0.20	---
L	0.30	0.50
L1	---	0.15

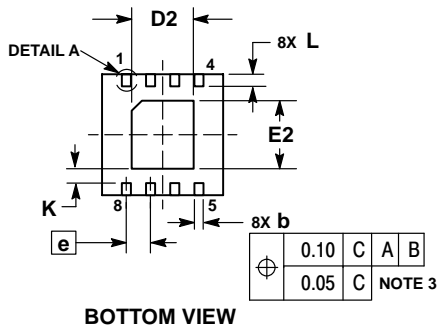

### SOLDERING FOOTPRINT\*

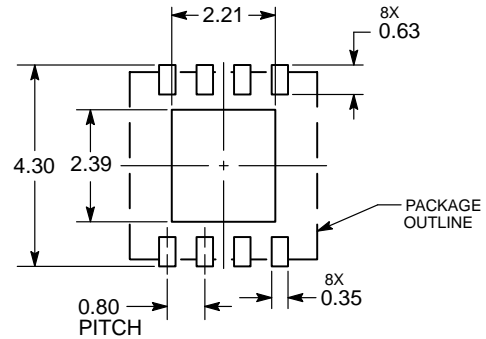

DIMENSIONS: MILLIMETERS

\*For additional information on our Pb-Free strategy and soldering details, please download the ON Semiconductor Soldering and Mounting Techniques Reference Manual, SOLDERRM/D.

# NCP4305

## PACKAGE DIMENSIONS

### WDFN8 2x2, 0.5P CASE 511AT ISSUE O

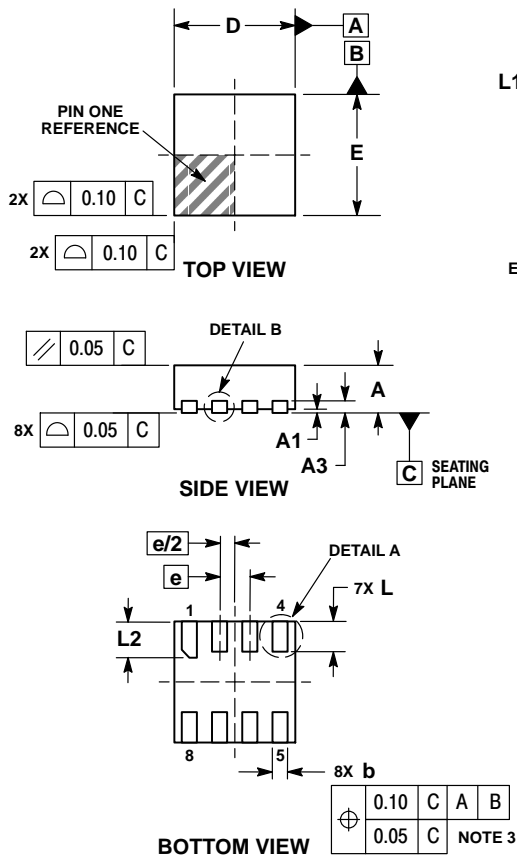

#### NOTES:

1. DIMENSIONING AND TOLERANCING PER ASME Y14.5M, 1994.
2. CONTROLLING DIMENSION: MILLIMETERS.
3. DIMENSION b APPLIES TO PLATED TERMINAL AND IS MEASURED BETWEEN 0.15 AND 0.30 MM FROM TERMINAL TIP.

DIM	MILLIMETERS	
	MIN	MAX
A	0.70	0.80
A1	0.00	0.05
A3	0.20 REF	
b	0.20	0.30
D	2.00 BSC	
E	2.00 BSC	
e	0.50 BSC	
L	0.40	0.60
L1	---	0.15
L2	0.50	0.70

### RECOMMENDED SOLDERING FOOTPRINT\*

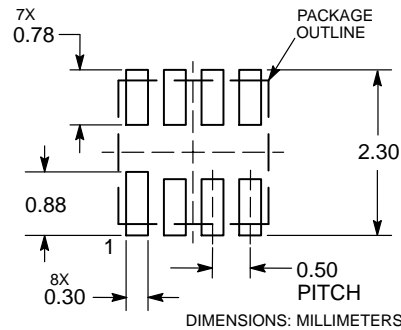

\*For additional information on our Pb-Free strategy and soldering details, please download the ON Semiconductor Soldering and Mounting Techniques Reference Manual, SOLDERRM/D.

ON Semiconductor and are trademarks of Semiconductor Components Industries, LLC dba ON Semiconductor or its subsidiaries in the United States and/or other countries. ON Semiconductor owns the rights to a number of patents, trademarks, copyrights, trade secrets, and other intellectual property. A listing of ON Semiconductor's product/patent coverage may be accessed at [www.onsemi.com/site/pdf/Patent-Marketing.pdf](http://www.onsemi.com/site/pdf/Patent-Marketing.pdf). ON Semiconductor reserves the right to make changes without further notice to any products herein. ON Semiconductor makes no warranty, representation or guarantee regarding the suitability of its products for any particular purpose, nor does ON Semiconductor assume any liability arising out of the application or use of any product or circuit, and specifically disclaims any and all liability, including without limitation special, consequential or incidental damages. Buyer is responsible for its products and applications using ON Semiconductor products, including compliance with all laws, regulations and safety requirements or standards, regardless of any support or applications information provided by ON Semiconductor. "Typical" parameters which may be provided in ON Semiconductor data sheets and/or specifications can and do vary in different applications and actual performance may vary over time. All operating parameters, including "Typicals" must be validated for each customer application by customer's technical experts. ON Semiconductor does not convey any license under its patent rights nor the rights of others. ON Semiconductor products are not designed, intended, or authorized for use as a critical component in life support systems or any FDA Class 3 medical devices or medical devices with a same or similar classification in a foreign jurisdiction or any devices intended for implantation in the human body. Should Buyer purchase or use ON Semiconductor products for any such unintended or unauthorized application, Buyer shall indemnify and hold ON Semiconductor and its officers, employees, subsidiaries, affiliates, and distributors harmless against all claims, costs, damages, and expenses, and reasonable attorney fees arising out of, directly or indirectly, any claim of personal injury or death associated with such unintended or unauthorized use, even if such claim alleges that ON Semiconductor was negligent regarding the design or manufacture of the part. ON Semiconductor is an Equal Opportunity/Affirmative Action Employer. This literature is subject to all applicable copyright laws and is not for resale in any manner.

### PUBLICATION ORDERING INFORMATION

#### LITERATURE FULFILLMENT:

Literature Distribution Center for ON Semiconductor  
19521 E. 32nd Pkwy, Aurora, Colorado 80011 USA  
Phone: 303-675-2175 or 800-344-3860 Toll Free USA/Canada  
Fax: 303-675-2176 or 800-344-3867 Toll Free USA/Canada  
Email: [orderlit@onsemi.com](mailto:orderlit@onsemi.com)

**N. American Technical Support:** 800-282-9855 Toll Free  
USA/Canada  
**Europe, Middle East and Africa Technical Support:**  
Phone: 421 33 790 2910  
**Japan Customer Focus Center**  
Phone: 81-3-5817-1050

**ON Semiconductor Website:** [www.onsemi.com](http://www.onsemi.com)

**Order Literature:** <http://www.onsemi.com/orderlit>

For additional information, please contact your local Sales Representative



Компания «ЭлектроПласт» предлагает заключение долгосрочных отношений при поставках импортных электронных компонентов на взаимовыгодных условиях!

Наши преимущества:

- Оперативные поставки широкого спектра электронных компонентов отечественного и импортного производства напрямую от производителей и с крупнейших мировых складов;
- Поставка более 17-ти миллионов наименований электронных компонентов;
- Поставка сложных, дефицитных, либо снятых с производства позиций;
- Оперативные сроки поставки под заказ (от 5 рабочих дней);
- Экспресс доставка в любую точку России;
- Техническая поддержка проекта, помощь в подборе аналогов, поставка прототипов;
- Система менеджмента качества сертифицирована по Международному стандарту ISO 9001;
- Лицензия ФСБ на осуществление работ с использованием сведений, составляющих государственную тайну;
- Поставка специализированных компонентов (Xilinx, Altera, Analog Devices, Intersil, Interpoint, Microsemi, Aeroflex, Peregrine, Syfer, Eurofarad, Texas Instrument, Miteq, Cobham, E2V, MA-COM, Hittite, Mini-Circuits, General Dynamics и др.);

Помимо этого, одним из направлений компании «ЭлектроПласт» является направление «Источники питания». Мы предлагаем Вам помощь Конструкторского отдела:

- Подбор оптимального решения, техническое обоснование при выборе компонента;
- Подбор аналогов;
- Консультации по применению компонента;
- Поставка образцов и прототипов;
- Техническая поддержка проекта;
- Защита от снятия компонента с производства.



#### Как с нами связаться

**Телефон:** 8 (812) 309 58 32 (многоканальный)

**Факс:** 8 (812) 320-02-42

**Электронная почта:** [org@eplast1.ru](mailto:org@eplast1.ru)

**Адрес:** 198099, г. Санкт-Петербург, ул. Калинина, дом 2, корпус 4, литера А.