

GENERAL DESCRIPTION

The XRP6272 is a low dropout voltage regulator capable of a constant output current up to 2 Amps. A wide 1.8V to 6V input voltage range allows for single supply operations from industry standard 1.8V, 2.8V, 3.3V, and 5V power rails as well as the 5.8V rail.

With better than $\pm 2\%$ output voltage accuracy, low output noise and high Power Supply Rejection Ratio (PSRR), the XRP6272 is perfectly suited for powering RF circuitries. Optimized for use with small low cost ESR ceramic output capacitors and featuring a low $30\mu\text{A}$ quiescent current, this device is also adequate for use in battery powered portable equipments. The XRP6272 operates by default as a 5V fixed output voltage regulator while usage of an external resistors divider allows adjustable out voltages as low as 0.7V. An Enable function, Power Good flag and output noise reduction pin complete the feature set.

Built-in current limit and thermal protections insure safe operations under abnormal operating conditions.

The XRP6272 is offered in RoHS compliant, "green"/halogen free 5-pin TO-252 and 8-pin exposed pad SOIC packages.

APPLICATIONS

- Networking Equipments
- RF Circuitry Power Supplies
- Set-top box Equipments
- Portable Equipments

FEATURES

- **Guaranteed 2A Output Current**
 - Low 550mV Dropout at 3.3V/2A
- **1.8V to 6V Single Input Voltage Range**
 - Fixed 5V and Adjustable Output Voltage
 - $\pm 2\%$ Output Voltage Accuracy
- **$30\mu\text{A}$ Quiescent Current**
- **Power Good and Enable Functions**
- **70dB Power Supply Rejection Ratio**
- **Low Output Noise**
- **$0.01\mu\text{A}$ Shutdown Current**
- **Current Limit and Thermal Protection**
- **RoHS compliant "Green"/Halogen Free 5-pin TO-252 and 8-pin Exposed pad SOIC Packages**

TYPICAL APPLICATION DIAGRAM

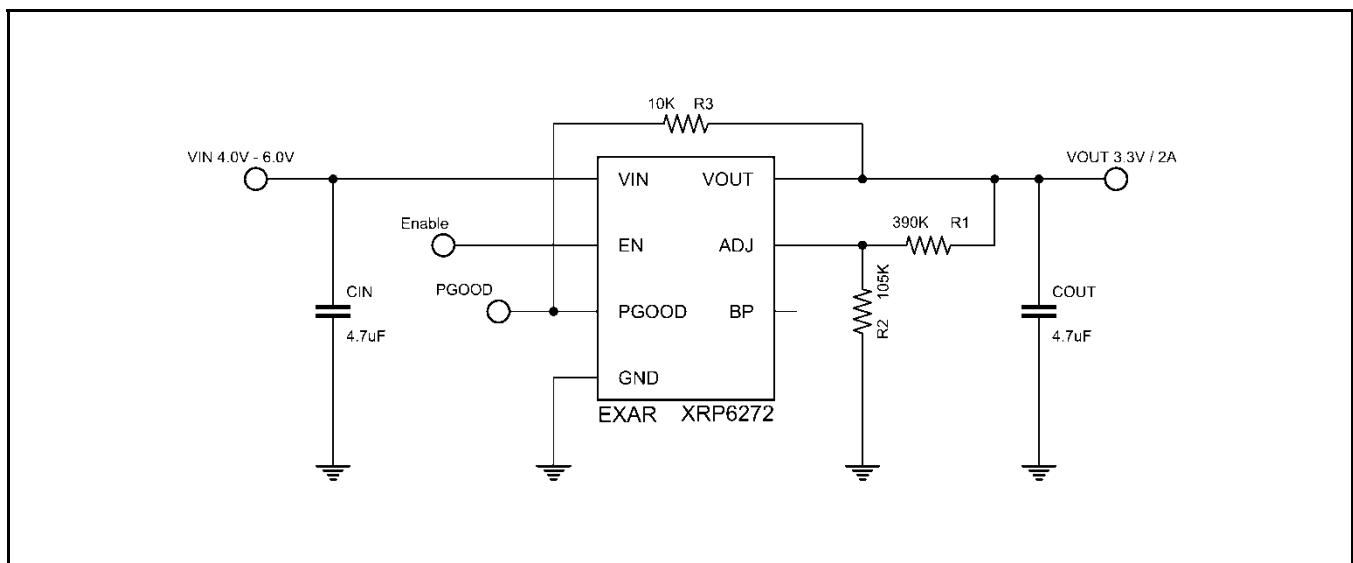

Fig. 1: XRP6272 Application Diagram



2A 5V-Adjustable Low Dropout Voltage Regulator

ABSOLUTE MAXIMUM RATINGS

These are stress ratings only and functional operation of the device at these ratings or any other above those indicated in the operation sections of the specifications below is not implied. Exposure to absolute maximum rating conditions for extended periods of time may affect reliability.

V_{IN} , EN, BP 7.0V
 Storage Temperature -65°C to 150°C
 Power Dissipation Internally Limited
 Lead Temperature (Soldering, 10 sec) 260°C
 Junction Temperature 150°C
 ESD Rating (HBM - Human Body Model) 2kV
 ESD Rating (MM - Machine Model) 500V

OPERATING RATINGS

Input Voltage Range V_{IN} 1.8V to 6V
 Operating Temperature Range..... -40°C to 85°C
 Thermal Resistance
 θ_{JA} (5-Pin TO-252).....100°C/W
 θ_{JC} (5-Pin TO-252)..... 8°C/W
 θ_{JA} (8-pin HSOIC)..... 60°C/W
 θ_{JC} (8-pin HSOIC)..... 15°C/W

ELECTRICAL SPECIFICATIONS

Specifications with standard type are for an Operating Junction Temperature of $T_J = 25^\circ\text{C}$ only. Minimum and Maximum limits are guaranteed through test, design, or statistical correlation. Typical values represent the most likely parametric norm at $T_J = 25^\circ\text{C}$, and are provided for reference purposes only. Unless otherwise indicated, $V_{IN} = V_{OUT} + 1\text{V}$, $C_{IN} = 4.7\mu\text{F}$, $C_{OUT} = 4.7\mu\text{F}$ or $10\mu\text{F}$ (Note 1), $C_{BYP} = 22\text{nF}$, $T_J = 25^\circ\text{C}$.

Parameter	Min.	Typ.	Max.	Units	Conditions
Input Voltage	1.8		6.0	V	
Output Voltage Tolerance	-2		+2	%	$I_{OUT} = 1\text{mA}$
Continuous Output Current	2			A	$V_{IN} \geq 2.3\text{V}$
Ground Current		30	50	μA	$V_{EN} \geq 1.6\text{V}$, No Load
		30	50		$V_{EN} \geq 1.6\text{V}$, $I_{OUT} = 300\text{mA}$
Standby Current		0.01	0.5	μA	$V_{EN} = 0$
Line Regulation		3	15	mV	$V_{IN} = V_{OUT} + 1\text{V}$ to 6V, $I_{OUT} = 1\text{mA}$
Load Regulation		5	15	mV	$I_{OUT} = 1\text{mA}$ to 2A
Output Current Limit	2.2	3.0	3.9	A	
Current Fold Back		1.0		A	
Dropout Voltage (Note 2)		960		mV	$I_{OUT} = 2\text{A}$, $V_{OUT} = 1.2\text{V}$
		700	900		$I_{OUT} = 2\text{A}$, $V_{OUT} = 1.8\text{V}$
		550	700		$I_{OUT} = 2\text{A}$, $V_{OUT} = 3.3\text{V}$
		480	600		$I_{OUT} = 2\text{A}$, $V_{OUT} = 5.0\text{V}$
Reference Voltage Tolerance	0.686	0.7	0.714	V	
ADJ Pin Current		10	100	nA	$V_{ADJ} = V_{REF}$
ADJ Pin Threshold	0.05	0.1	0.2	V	
Enable Turn-On Threshold	1.6			V	Output ON
Enable Turn-Off Threshold			0.4	V	Output OFF
Shutdown Pin Current		0	0.5	μA	$V_{EN} = 0$
Shutdown Exit Delay Time		100		μs	
Max Output Discharge Resistance to GND during Shutdown		20	100	Ω	
PGOOD Rise Threshold		90	93	%	
PGOOD Hysteresis	3	10		%	
PGOOD Delay	0.5		5	ms	
PGOOD Sink Capability		0.2	0.4	V	$I_{PGOOD} = 10\text{mA}$
Ripple Rejection		70		dB	$f=1\text{KHz}$, Ripple=0.5Vp-p
Output Noise Voltage		24		μVrms	$C_{BP} = 22\text{nF}$, $f=10\text{Hz} \sim 100\text{KHz}$
Temperature Coefficient		50		ppm/°C	
Thermal Shutdown Temperature		150		°C	$V_{IN} = V_{OUT} + 1\text{V}$
Thermal Shutdown Hysteresis		20		°C	

2A 5V-Adjustable Low Dropout Voltage Regulator

Note 1: In the case of $V_{OUT} \leq 1.8V$, $C_{OUT} = 10\mu F$ is recommended.

Note 2: Dropout Voltage is defined as input voltage minus output voltage when the output voltage drops by 1% of its nominal value at $V_{IN} = V_{OUT} + 1V$.

Note 3: $V_{IN(min)}$ is the higher value of $(V_{OUT} + \text{Dropout Voltage})$ or 1.8V.

BLOCK DIAGRAM

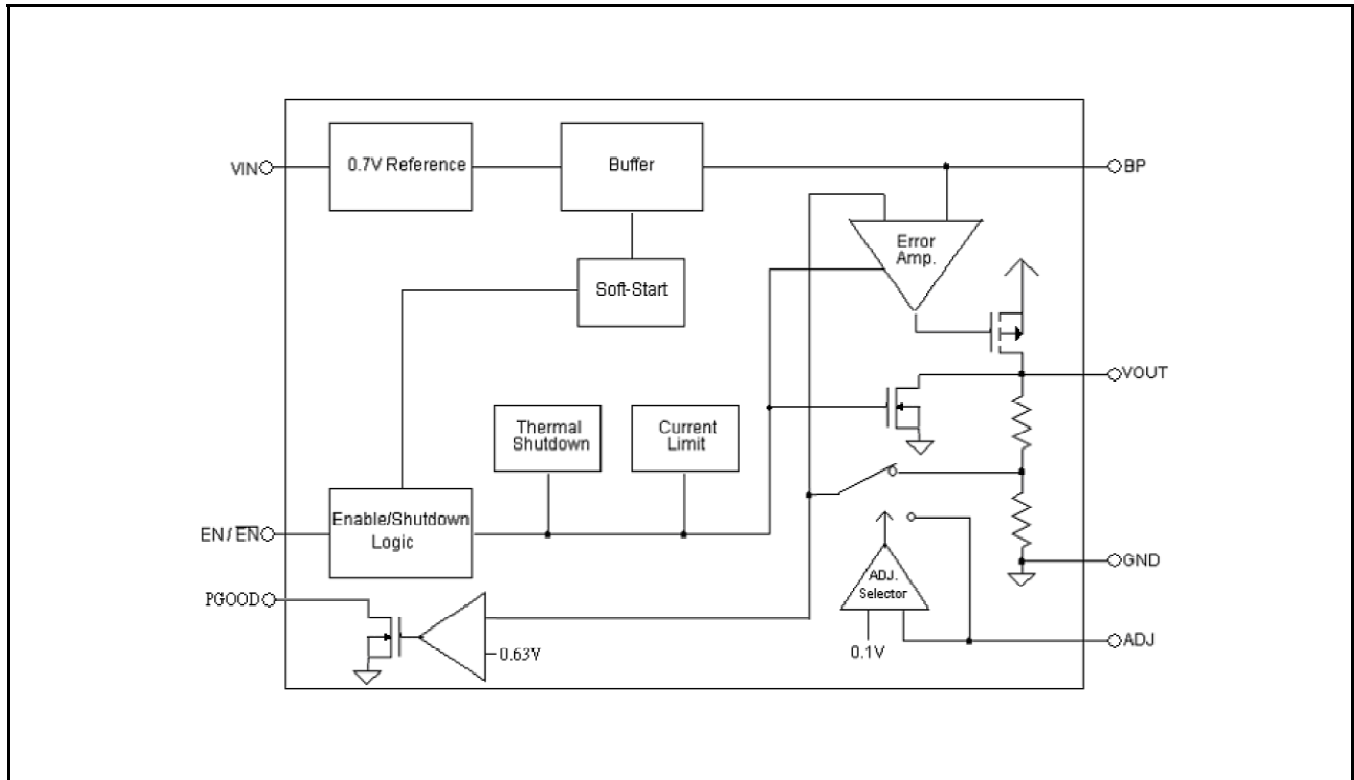

Fig. 2: XRP6272 Block Diagram

PIN ASSIGNMENT

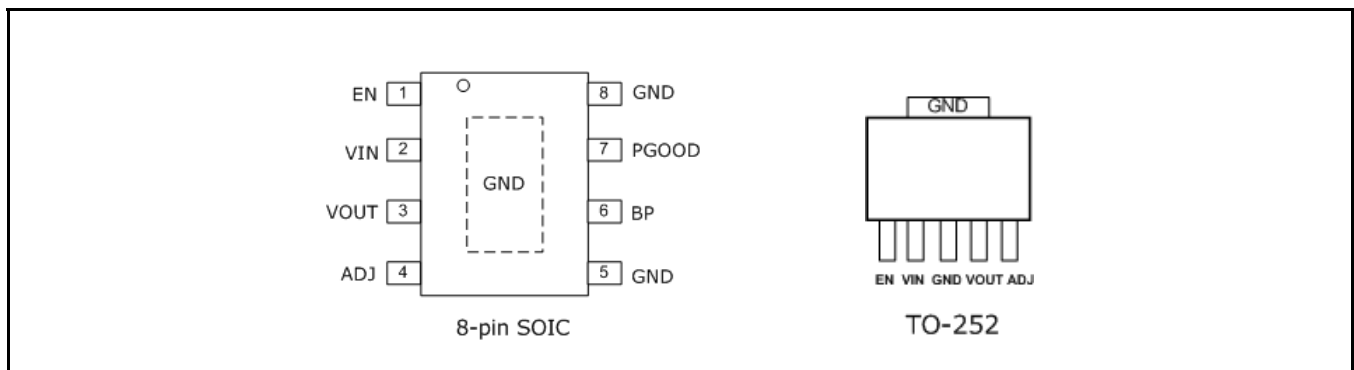

Fig. 3: XRP6272 Pin Assignment



PIN DESCRIPTION

Name	SOIC-8	TO-252	Description
EN	1	1	Enable Pin. Minimum 1.6V to enable the device. Maximum 0.4V to shutdown the device.
VIN	2	2	Power Input Pin. Must be closely decoupled to GND pin with a 4.7μF or greater ceramic capacitor.
VOUT	3	4	Regulator Output pin.
ADJ	4	5	Adjustable Pin. Output Voltage can be set by external feedback resistors when using a resistive divider. Or, connect ADJ to GND for VOUT = 5V, set by internal feedback resistors.
GND	5, 8	3	Ground Signal
BP	6	-	Bypass pin. Connect a 22nF capacitor to GND to reduce output noise. Bypass pin can be left floating if not necessary.
PGOOD	7	-	Power Good open Drain Output.
GND	Exposed Pad	Tab	Connect to GND.

ORDERING INFORMATION

Part Number	Temperature Range	Marking	Package	Packing Quantity	Note 1	Note 2
XRP6272ITC5TR-F	-40°C ≤ T _A ≤ +85°C	EXAR XRP6272ITC5 YYWWF X	5-pin TO-252	2K/Tape & Reel	RoHS Compliant Halogen Free	
XRP6272IDBTR-F	-40°C ≤ T _A ≤ +85°C	XRP6272I YYWWF XXXX	8-pin HSOIC	2.5K/Tape & Reel	RoHS Compliant Halogen Free	

“YY” = Year – “WW” = Work Week – “X” = Lot Number; when applicable.

TYPICAL PERFORMANCE CHARACTERISTICS

All data taken at $V_{IN} = V_{OUT} + 1V$, $T_J = T_A = 25^\circ C$, $C_{IN} = 4.7\mu F$, $C_{OUT} = 4.7\mu F$ or $10\mu F$ (Note 1) unless otherwise specified.

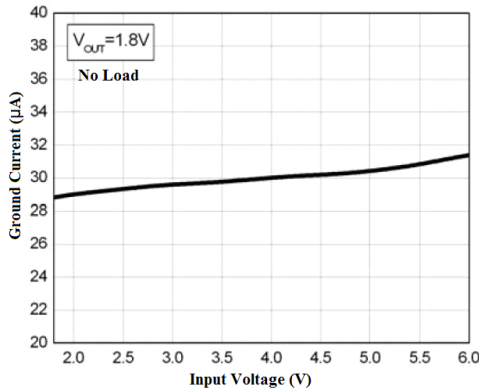

Fig. 4: GND Current vs. VIN at VOUT=1.8V, No Load

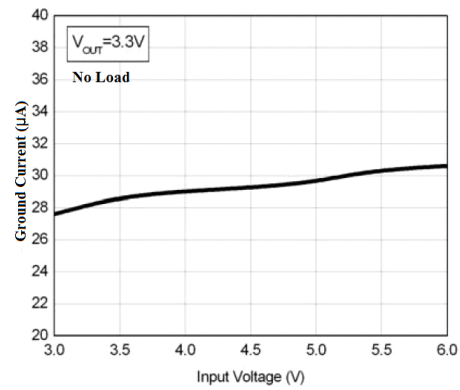

Fig. 5: GND Current vs. VIN at VOUT=3.3V, No Load

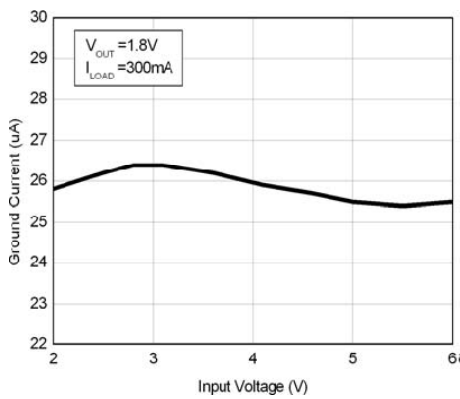

Fig. 6: GND Current vs. VIN at VOUT=1.8V, 300mA

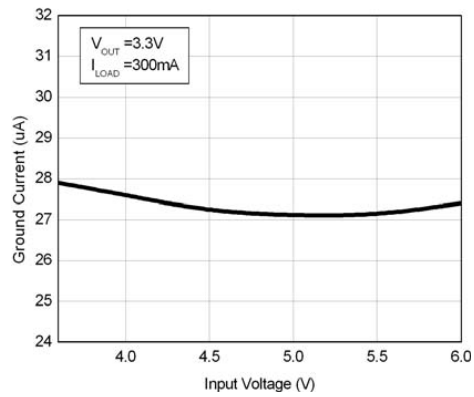

Fig. 7: GND Current vs. VIN at VOUT=3.3V, 300mA

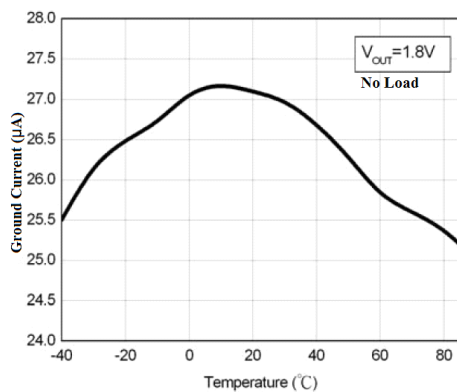

Fig. 8: GND Current vs. Temp. at VOUT=1.8V, No Load

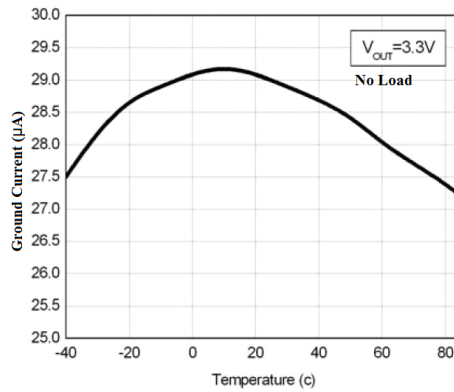

Fig. 9: GND Current vs. Temp. at VOUT=3.3V, No Load

2A 5V-Adjustable Low Dropout Voltage Regulator

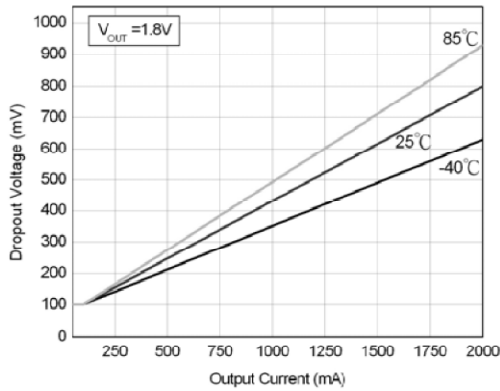

Fig. 10: Dropout Voltage at $V_{OUT} = 1.8V$

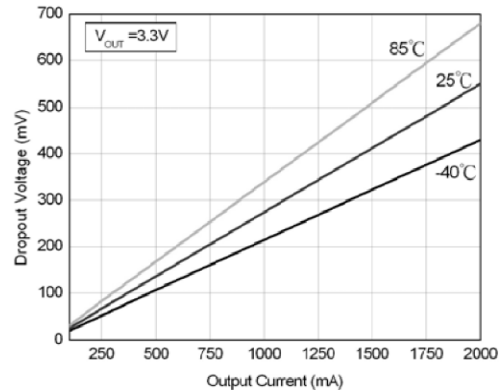

Fig. 11: Dropout Voltage at $V_{OUT} = 3.3V$

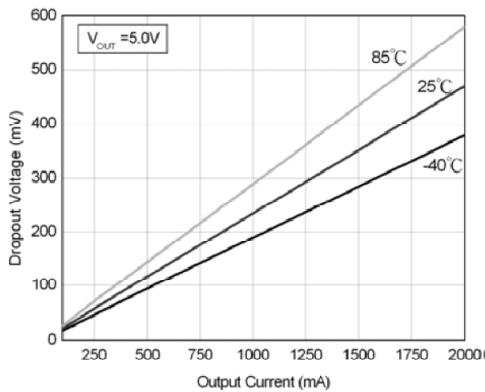

Fig. 12: Dropout Voltage at $V_{OUT} = 5.0V$

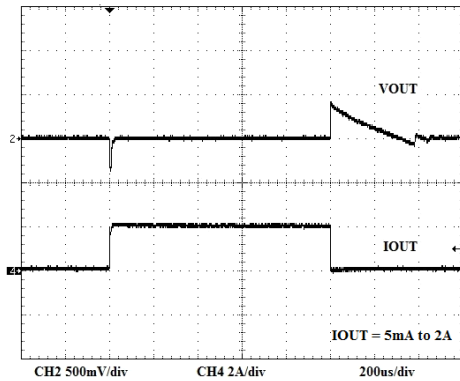

Fig. 13: Load Transient Response at $V_{OUT}=1.8V, V_{IN}=2.8V$

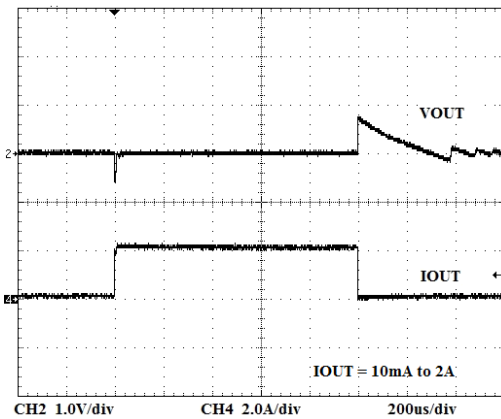

Fig. 14: Load Transient Response at $V_{OUT}=3.3V, V_{IN}=4.3V$

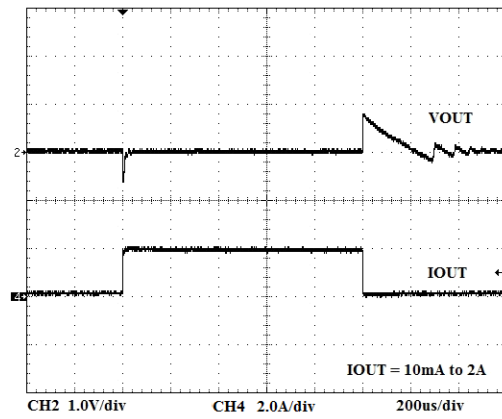

Fig. 15: Load Transient Response at $V_{OUT}=5V, V_{IN}=6V$

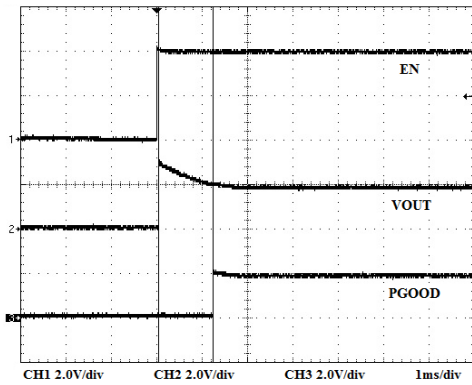

Fig. 16: Enable Startup at VOUT = 1.8V

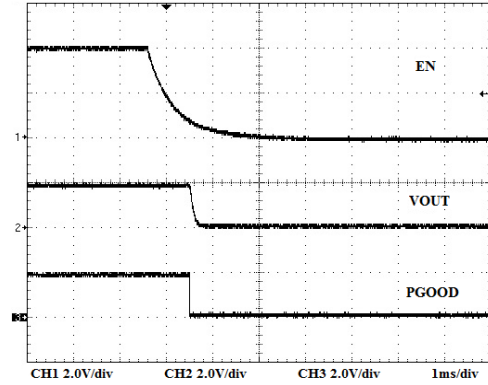

Fig. 17: Shutdown at VOUT = 1.8V

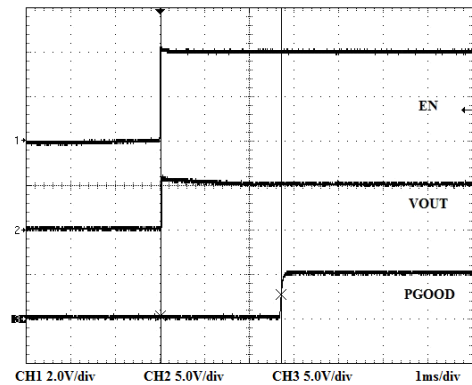

Fig. 18: Enable Startup at VOUT = 5V

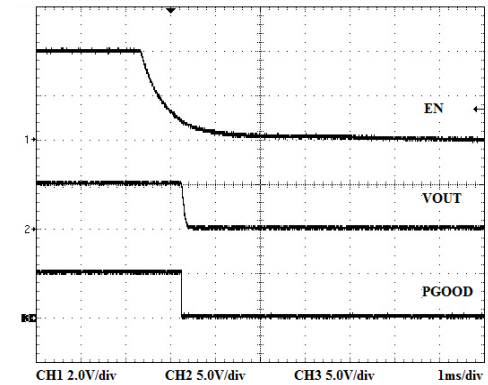

Fig. 19: Shutdown at VOUT = 5V

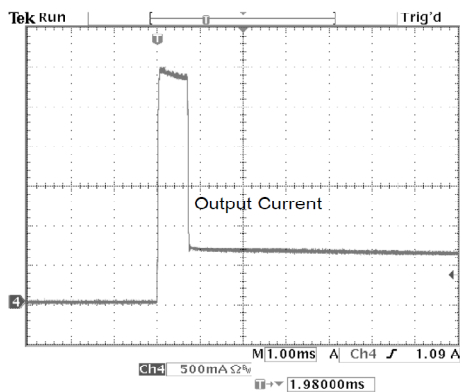

Fig. 20: Current Foldback at VOUT = 1.8V

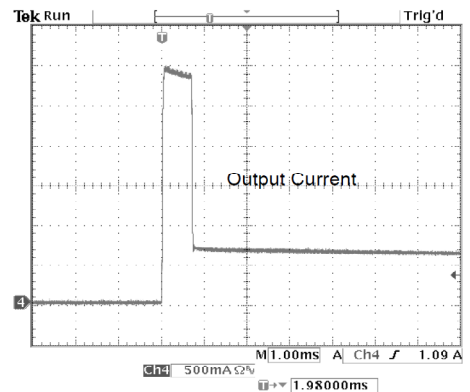

Fig. 21: Current Foldback at VOUT = 3.3V

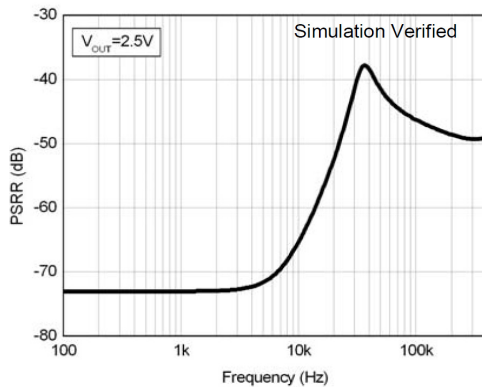

Fig. 22: PSRR Curve

APPLICATION INFORMATION

The XRP6272 is a low-dropout voltage regulator with low quiescent current, low noise and high PSRR. It can support load current up to 2A. It incorporates current-limit and thermal protection features.

an output ceramic capacitor of at least 4.7μF or 10μF (for $V_{OUT} \leq 1.8V$) is recommended. An input capacitor of 4.7μF is recommended.

X5R or X7R ceramic capacitors are recommended as they have the best temperature and voltage characteristics.

TYPICAL APPLICATION SCHEMATIC

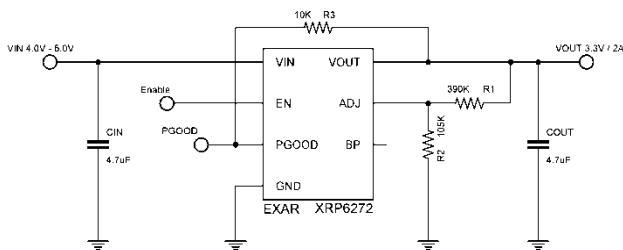

PROGRAMMING THE OUTPUT VOLTAGE

XRP6272's internal feedback resistors set the output voltage V_{OUT} to 5V when the ADJ pin is connected to GND. Alternatively; the output voltage is adjustable via the external feedback resistor network R1 and R2 by calculating the following formula:

$$V_{OUT} = V_{REF} \times \left(1 + \frac{R1}{R2} \right)$$

where, V_{REF} is the reference voltage set internally at 0.7V nominal.

INPUT & OUTPUT CAPACITORS

XRP6272 is optimized for use with ceramic capacitors. To ensure stability of the device,

NOISE BYPASS CAPACITOR

A 22nF bypass capacitor at BP pin can reduce output voltage noise. This pin can be left floating if it is unnecessary.

THEORY OF OPERATION

SHUTDOWN

By connecting EN pin to GND, the XRP6272 can be shutdown to reduce the supply current to 0.01μA (typ.). In this mode, the output voltage of XRP6272 is equal to 0V.

CURRENT LIMIT

The XRP6272 includes current limit protection feature, which monitors and controls the maximum output current. If the output is overloaded or shorted to ground, this can protect the device from being damaged.

THERMAL PROTECTION

The XRP6272 includes a thermal protection feature that protects the IC by turning off the pass transistor when the maximum junction temperature T_J exceeds 150°C.

**2A 5V-Adjustable Low Dropout Voltage Regulator**

POWER DISSIPATION

The power dissipation across the device can be calculated as:

$$P_D = I_{OUT} \times (V_{IN} - V_{OUT})$$

The total junction temperature is calculated as:

$$T_J = T_A + P_D \times \theta_{JA}$$

where, T_J is the junction temperature, T_A is the ambient temperature and θ_{JA} is the thermal resistance between junction to ambient.

There is a temperature rise associated with this power dissipated while operating in a given ambient temperature. If the calculated junction temperature exceeds maximum junction temperature specification, then the built-in thermal protection feature is triggered as described previously.

To insure reliable performance, the maximum allowable power dissipation for a given ambient temperature must be considered and it can be calculated as follows:

$$P_{D(MAX)} = (T_{J(MAX)} - (T_A)) / \theta_{JA}$$

where, $T_{J(MAX)}$ is the maximum junction temperature, T_A is the ambient temperature and θ_{JA} is the thermal resistance between junction to ambient. In order to insure the best thermal flow, proper mounting of the IC is required.

LAYOUT CONSIDERATION

1. Connect the bottom-side pad to a large ground plane for good thermal conductivity and to reduce the thermal resistance of the device.
2. The input capacitor C_{IN} and output capacitor C_{OUT} must be placed as close as possible to the pins V_{IN} and V_{OUT} respectively.
3. Use short wires to connect the power supply to pins V_{IN} and GND on the board.

TYPICAL APPLICATIONS

APPLICATION 1

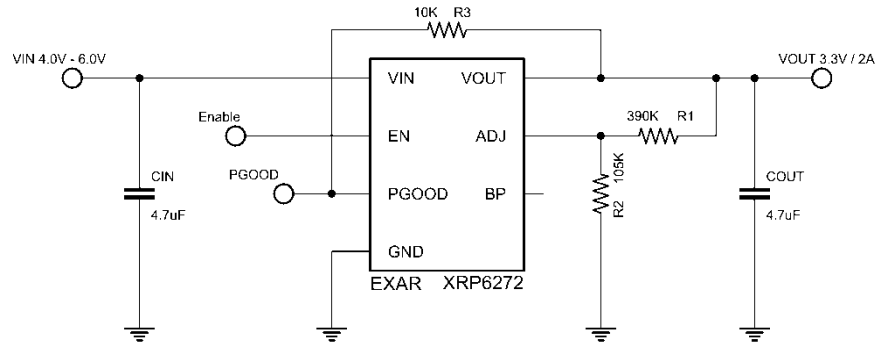

Fig. 23: 5V to 3.3V / 2A

APPLICATION 2

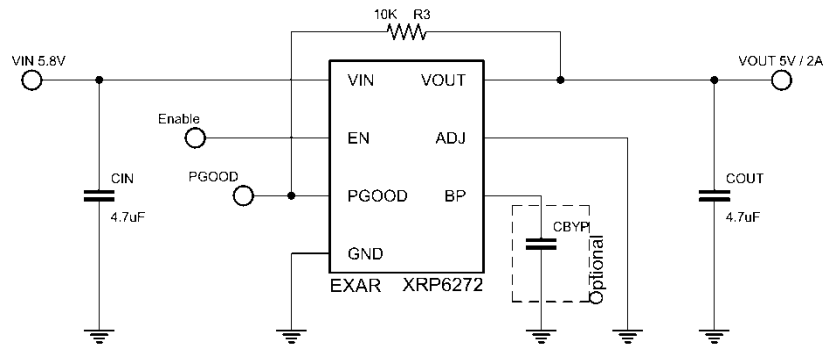

Fig. 24: 5.8V to 5V RF Stage Low Noise Power Supply

APPLICATION 3

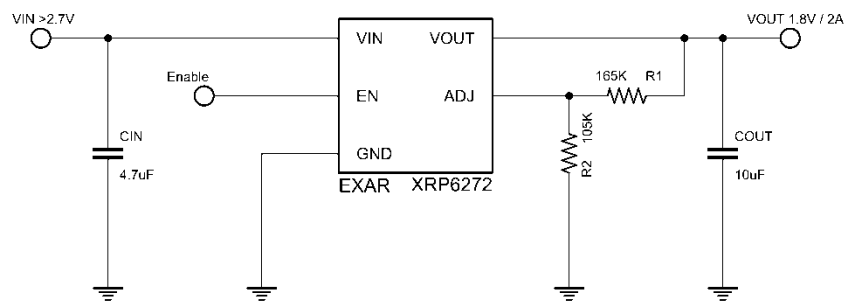
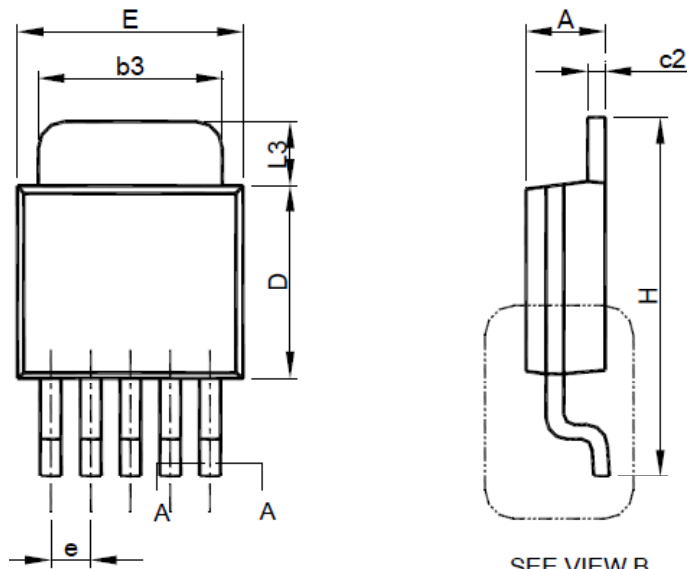

Fig. 25: 2.7V Min to 1.8V / 2A Power Supply

PACKAGE SPECIFICATION

TO-252-5L



SEE VIEW B

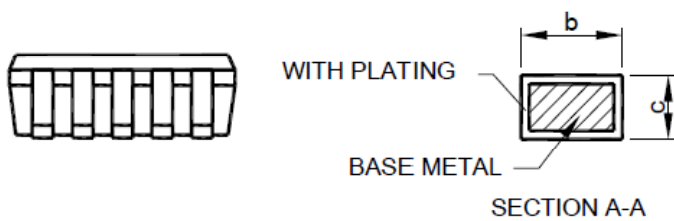

SYMBOL	TO-252-5L	
	MILLIMETERS	
	MIN.	MAX.
A	2.19	2.38
A1	0.00	0.13
b	0.51	0.71
b3	4.32	5.46
c	0.46	0.61
c2	0.46	0.89
D	5.33	6.22
E	6.35	6.73
e	1.27 BSC	
H	9.40	10.41
L	1.40	1.78
L1	2.67 REF	
L2	0.51 BSC	
L3	0.89	2.03
q	0°	8°

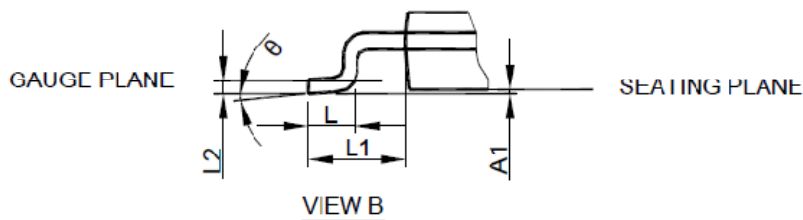

- Note: 1. Refer to JEDEC TO-252AD and AB.
 2. Dimension "E" does not include mold flash, protrusions or gate burrs. Mold flash, protrusion or gate burrs shall not exceed 6 mil per side .
 3. Dimension "D" does not include inter-lead flash or protrusions.
 4. Controlling dimension is millimeter, converted inch dimensions are not necessarily exact.

EXPOSED PAD 8-PIN SOIC

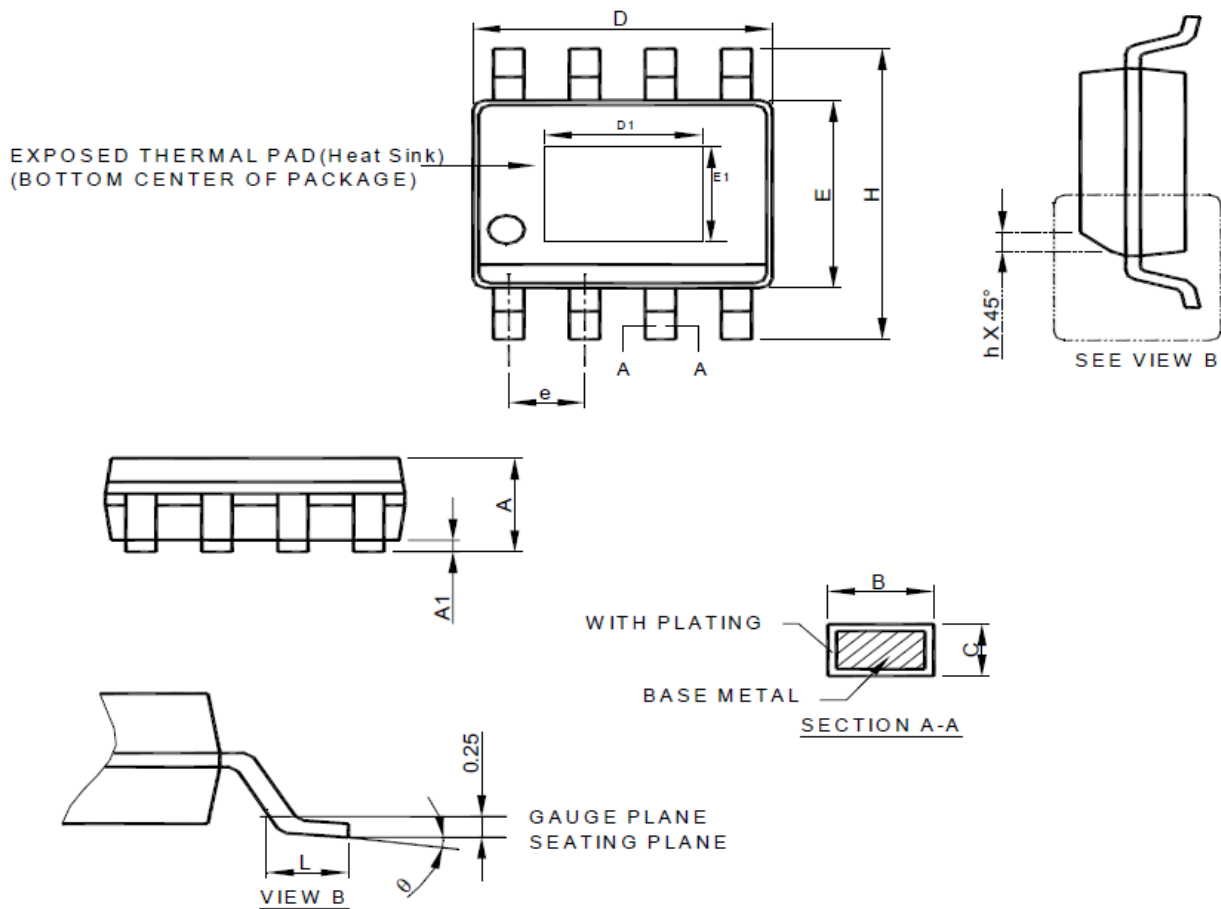

SYMBOL	SOP-8 Exposed Pad(Heat Sink)	
	MILLIMETERS	
	MIN.	MAX.
A	1.35	1.75
A1	0.00	0.15
B	0.31	0.51
C	0.17	0.25
D	4.80	5.00
E	3.80	4.00
e	1.27 BSC	
H	5.80	6.20
h	0.25	0.50
L	0.40	1.27
q	0°	8°
D1	1.5	3.5
E1	1.0	2.55

- Note : 1. Refer to JEDEC MS-012E.
 2. Dimension "D" does not include mold flash, protrusions or gate burrs. Mold flash, protrusion or gate burrs shall not exceed 6 mil per side .
 3. Dimension "E" does not include inter-lead flash or protrusions.
 4. Controlling dimension is millimeter, converted inch dimensions are not necessarily exact.



REVISION HISTORY

Revision	Date	Description
1.1.0	10/14/2011	Initial release of Data Sheet
1.2.0	11/30/2011	Corrected pin assignment package drawing

FOR FURTHER ASSISTANCE

Email:

customersupport@exar.com

Exar Technical Documentation:

<http://www.exar.com/TechDoc/default.aspx?>

EXAR CORPORATION

HEADQUARTERS AND SALES OFFICES

48720 Kato Road

Fremont, CA 94538 – USA

Tel.: +1 (510) 668-7000

Fax: +1 (510) 668-7030

www.exar.com



NOTICE

EXAR Corporation reserves the right to make changes to the products contained in this publication in order to improve design, performance or reliability. EXAR Corporation assumes no responsibility for the use of any circuits described herein, conveys no license under any patent or other right, and makes no representation that the circuits are free of patent infringement. Charts and schedules contained here in are only for illustration purposes and may vary depending upon a user's specific application. While the information in this publication has been carefully checked; no responsibility, however, is assumed for inaccuracies.

EXAR Corporation does not recommend the use of any of its products in life support applications where the failure or malfunction of the product can reasonably be expected to cause failure of the life support system or to significantly affect its safety or effectiveness. Products are not authorized for use in such applications unless EXAR Corporation receives, in writing, assurances to its satisfaction that: (a) the risk of injury or damage has been minimized; (b) the user assumes all such risks; (c) potential liability of EXAR Corporation is adequately protected under the circumstances.

Reproduction, in part or whole, without the prior written consent of EXAR Corporation is prohibited.



Компания «ЭлектроПласт» предлагает заключение долгосрочных отношений при поставках импортных электронных компонентов на взаимовыгодных условиях!

Наши преимущества:

- Оперативные поставки широкого спектра электронных компонентов отечественного и импортного производства напрямую от производителей и с крупнейших мировых складов;
- Поставка более 17-ти миллионов наименований электронных компонентов;
- Поставка сложных, дефицитных, либо снятых с производства позиций;
- Оперативные сроки поставки под заказ (от 5 рабочих дней);
- Экспресс доставка в любую точку России;
- Техническая поддержка проекта, помощь в подборе аналогов, поставка прототипов;
- Система менеджмента качества сертифицирована по Международному стандарту ISO 9001;
- Лицензия ФСБ на осуществление работ с использованием сведений, составляющих государственную тайну;
- Поставка специализированных компонентов (Xilinx, Altera, Analog Devices, Intersil, Interpoint, Microsemi, Aeroflex, Peregrine, Syfer, Eurofarad, Texas Instrument, Miteq, Cobham, E2V, MA-COM, Hittite, Mini-Circuits, General Dynamics и др.);

Помимо этого, одним из направлений компании «ЭлектроПласт» является направление «Источники питания». Мы предлагаем Вам помощь Конструкторского отдела:

- Подбор оптимального решения, техническое обоснование при выборе компонента;
- Подбор аналогов;
- Консультации по применению компонента;
- Поставка образцов и прототипов;
- Техническая поддержка проекта;
- Защита от снятия компонента с производства.



Как с нами связаться

Телефон: 8 (812) 309 58 32 (многоканальный)

Факс: 8 (812) 320-02-42

Электронная почта: org@eplast1.ru

Адрес: 198099, г. Санкт-Петербург, ул. Калинина, дом 2, корпус 4, литера А.