

PSR-MC20

Safety relay for emergency stop and safety door monitoring

Data sheet
106172_en_03

© PHOENIX CONTACT 2015-08-21

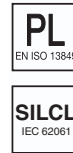

1 Description

Intended Use

The **PSR-MC20** safety relay can be used to monitor single-channel signal generators, e.g., emergency stop buttons and safety door locking mechanisms, and to control actuators.

The safety relay is equipped with three enabling current paths that drop out without delay corresponding to stop category 0 according to EN 60204-1.

The enabling current paths are controlled as an automatic or manual, monitored start once the sensor circuit has been closed.

With the manual, monitored reset device, a machine start may not be triggered in accordance with EN ISO 13849-1.

Features

- Safety relay for emergency stop and safety door monitoring
- Suitable up to category 1, PL c (EN ISO 13849-1), SILCL 1 (EN 62061)
- Depending on the application, suitable up to category 4, PL e (EN ISO 13849-1), SILCL 3 (EN 62061)
- 1 single-channel sensor circuit
- 3 undelayed enabling current paths
- 1 digital signal output
- Option of screw or spring-cage terminal blocks for plug-in
- 12.5 mm housing width



WARNING: Risk of electric shock

Observe the safety instructions in the corresponding section!



Make sure you always use the latest documentation. It can be downloaded from the product at phoenixcontact.net/products.



This document meets the same requirements as the original operating instructions in terms of contents and is valid for all products listed in the "Ordering data" section.

2	Table of contents	
1	Description	1
2	Table of contents	2
3	Ordering data	3
4	Technical data	3
5	Safety notes.....	6
6	Basic circuit diagram	7
7	Derating.....	7
	7.1 Vertical or horizontal mounting position	7
8	Load curve.....	7
	8.1 Ohmic load	7
9	Function/time diagrams	8
	9.1 Time diagram for automatic start	8
	9.2 Time diagram for manual, monitored start	8
10	Operating and indication elements	9
	10.1 Connection versions	9
	10.2 Connection assignment.....	9
11	Mounting and connection	10
12	Startup.....	10
13	Calculating the power dissipation	11
14	Diagnostics.....	12
	14.1 General states	12
	14.2 Error Messages.....	12
15	Application examples	14
	15.1 Emergency stop monitoring/automatic start.....	14
	15.2 Emergency stop monitoring/manual, monitored start	14
	15.3 Safety door monitoring/automatic start	15
	15.4 Safety door monitoring/manual, monitored start.....	15
	15.5 Connection to failsafe controller/automatic start	16
16	Revision history	17

3 Ordering data

Description	Type	Order No.	Pcs. / Pkt.
Safety relay for emergency stop and safety doors up to SIL 1, SILCL 1, Cat. 1, PL c, depending on the application up to SIL 3, SILCL 3, Cat. 4, PL e, 1-channel operation, automatic/manual start, 3 enabling current paths, $U_S = 24$ V DC, plug-in screw terminal block	PSR-MC20-3NO-1DO-24DC-SC	2700466	1
Safety relay for emergency stop/safety doors up to SIL 1, SILCL 1, Cat. 1, PL c, depending on the application up to SIL 3, SILCL 3, Cat. 4, PL e, 1-channel operation, automatic/manual start, 3 enabling current paths, $U_S = 24$ V DC, plug-in spring-cage terminal block	PSR-MC20-3NO-1DO-24DC-SP	2700467	1

4 Technical data

Hardware/firmware version	
HW/FW	≥ 00/-- (The technical data and safety characteristics are valid as of the specified HW/FW version.)
Input data	
Rated control supply voltage U_S	24 V DC -15 % / +10 %
Rated control supply current I_S	typ. 80 mA
Input voltage range "0"-signal	0 V DC ... 5 V DC (for safe off)
Typical inrush current	5 A ($\Delta t = 200 \mu s$ at U_S) < 21 mA (with U_S/I_x to S12) < 200 mA (with U_S/I_x to S34)
Current consumption	< 5 mA (with U_S/I_x to S12) < 10 mA (with U_S/I_x to S34) > -5 mA (with U_S/I_x to S34)
Power consumption at U_S	typ. 1.92 W
Voltage at input/start and feedback circuit	24 V DC -15 % / +10 %
Filter time	1 ms (at A1 in the event of voltage dips at U_S) max. 1.5 ms (at S12; test pulse width) min. 7.5 ms (at S12; test pulse rate) Test pulse rate = 5 x Test pulse width
Max. permissible overall conductor resistance (Input and reset circuit at U_S)	150 Ω
Typical response time at U_S	< 175 ms (automatic start) < 175 ms (manual, monitored start)
Typical starting time with U_S	< 250 ms (when controlled via A1)
Typical release time with U_S	< 20 ms (when controlled via A1 or S12)
Recovery time	< 500 ms
Maximum switching frequency	0.5 Hz
Operating voltage display	1 x green LED
Status display	3 x green LED
Protective circuit	Surge protection Suppressor diode Reverse polarity protection for rated control supply voltage
Output data	
Contact type	3 enabling current paths
Contact material	AgSnO ₂
Minimum switching voltage	20 V AC/DC
Maximum switching voltage	250 V AC/DC
Limiting continuous current	6 A (N/O contact)
Maximum inrush current	6 A
Inrush current, minimum	3 mA

Output data		
Sq. Total current	48 A ² (see to derating)	
Switching capacity min.	60 mW	
Mechanical service life	10 x 10 ⁶ cycles	
Output fuse	6 A gL/gG (N/O contact) 4 A gL/gG (for low-demand applications)	
Alarm outputs		
Number of outputs	1 (digital, PNP)	
Voltage	22 V DC (U _S - 2 V)	
Current	max. 100 mA	
Maximum inrush current	500 mA (Δt = 1 ms at U _S)	
Short-circuit protection	no	
General data		
Relay type	Electromechanical relay with forcibly guided contacts in accordance with IEC/EN 61810-3 (EN 50205)	
Nominal operating mode	100% operating factor	
Degree of protection	IP20	
Min. degree of protection of inst. location	IP54	
Mounting type	DIN rail mounting	
Mounting position	vertical or horizontal	
Assembly instructions	See derating curve	
Type of housing	PBT yellow	
Clearances and creepage distances between the power circuits	DIN EN 50178	
Rated insulation voltage	250 V AC	
Rated surge voltage/insulation	Safe isolation, reinforced insulation 6 kV between input circuit and enabling current path (13/14) and enabling current path (23/24) and enabling current path (33/34) Basic insulation 4 kV between all current paths and housing	
Pollution degree	2	
Surge voltage category	III	
Dimensions	Screw connection	Spring-cage connection
W x H x D	12.5 x 112.2 x 114.5 mm	12.5 x 116.6 x 114.5 mm
Connection data	Screw connection	Spring-cage connection
Conductor cross section, solid	0.2 mm ² ... 2.5 mm ²	0.2 mm ² ... 1.5 mm ²
Conductor cross section, stranded	0.2 mm ² ... 2.5 mm ²	0.2 mm ² ... 1.5 mm ²
Conductor cross section AWG/kcmil	24 ... 12	24 ... 16
Stripping length	7 mm	8 mm
Screw thread	M3	
Ambient conditions		
Ambient temperature (operation)	-40 °C ... 55 °C (observe derating)	
Ambient temperature (storage/transport)	-40 °C ... 85 °C	
Max. permissible relative humidity (operation)	75 % (on average, 85% infrequently, non-condensing)	
Max. permissible humidity (storage/transport)	75 % (on average, 85% infrequently, non-condensing)	
Maximum altitude	max. 2000 m (Above sea level)	
Shock	15g	
Vibration (operation)	10 Hz ... 150 Hz, 2g	

Conformance / approvals

Conformance	CE-compliant
Approvals	

Safety data

Stop category according to IEC 60204	0
--------------------------------------	---

Safety parameters for IEC 61508 - High demand

SIL	1 (up to SIL 3 depending on the application)
PFH _d	1.5×10^{-9} (4 A DC13; 5 A AC15; 8760 switching cycles/year)
Demand rate	< 12 Months
Proof test interval	240 Months
Duration of use	240 Months

Safety parameters for IEC 61508 - Low demand

SIL	1 (up to SIL 3 depending on the application)
PFD _{avg}	$1,46 \times 10^{-4}$
Proof test interval	60 Months
Duration of use	240 Months

Safety parameters for EN 62061

SIL CL	1 (up to SIL CL 3 depending on the application)
--------	---

Safety characteristic data according to EN ISO 13849

Category	1 (up to Cat. 4 depending on the application)
Performance level	c (up to PL e depending on the application)
Duration of use	240 Months
For applications in PL e, the required demand rate for the safety function is	once per month.
Calculation basis	4 A DC13; 5 A AC15; 8760 switching cycles/year

5 Safety notes



WARNING: Risk of electric shock

During operation, parts of electrical switching devices carry hazardous voltages.

Before working on the switching device, disconnect the power.

Please observe the safety regulations of electrical engineering and industrial safety and liability associations!

Disregarding these safety regulations may result in death, serious personal injury or damage to equipment.

Startup, mounting, modifications, and upgrades should only be carried out by a skilled electrical engineer!



WARNING: Risk of automatic machine restart!

For emergency stop applications, the machine must be prevented from restarting automatically by a higher-level control system.

Protective covers must not be removed when operating electrical switching devices.



WARNING: Danger due to faulty devices!

The devices may be damaged following an error and correct operation can no longer be ensured.

In the event of an error, replace the device immediately.

Repairs to the device, especially if the housing must be opened, may only be carried out by the manufacturer or authorized persons. Otherwise the warranty is invalidated.



WARNING: Risk of automatic machine restart!

When using the manual reset function with monitored start, the "cross-circuit between A2 (0 V) and the cable from the reset button to S34" error must be prevented by design-related measures, especially for safety functions with increased risk potential (see EN ISO 13849-2).



WARNING: Risk due to incorrect installation

For reliable operation, the safety relay must be installed in housing protected from dust and humidity (IP54).

Carry out wiring according to the application. Refer to the "Application examples" section for this.



WARNING: Risk due to welded relay contacts

A suitable and effective protective circuit is to be provided for inductive loads. This is to be implemented parallel to the load and not parallel to the switch contact.



WARNING: danger due to magnetic interference!

Do not use the device in the vicinity of strong magnetic fields (e.g., caused by transformers or magnetic iron). The magnetic field strength of the environment must not exceed 30 A/m.



NOTE: Risk of damage to equipment due to noise emissions

When operating relay modules the operator must meet the requirements for noise emission for electrical and electronic equipment (EN 61000-6-4) on the contact side and, if required, take appropriate measures.



NOTE: Risk of damage to equipment due to noise emissions

This is a Class A product. In a domestic environment it may cause radion interference, in which case the user may be required to take adequate measures.



Only use power supply units with safe isolation and SELV / PELV in accordance with EN 50178/VDE 0160 (SELV / PELV).

6 Basic circuit diagram

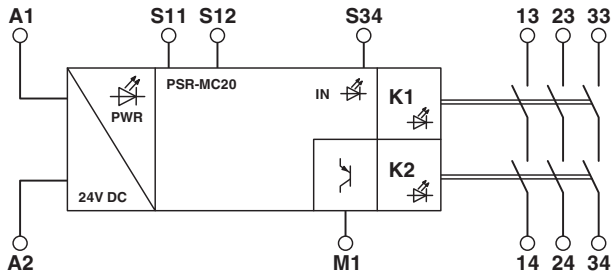

Figure 1 Block diagram

Key:

Designation	Explanation
A1	+24 V power supply
A2	0 V power supply
M1	Signal output (PNP)
S11	Output 24 V
S12	Input sensor circuit
S34	Start circuit
13/14	Undelayed enabling current paths
23/24	
33/34	

8 Load curve

8.1 Ohmic load

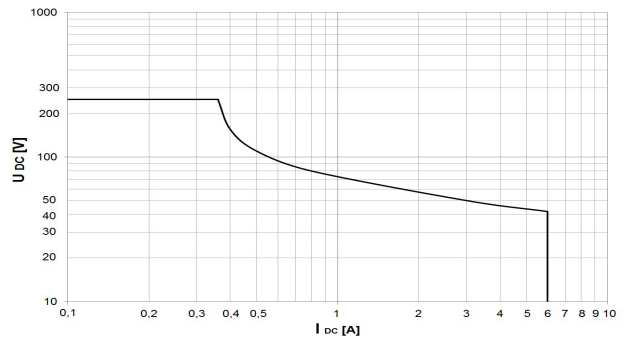

Figure 3 Relay load curve - ohmic load

7 Derating

7.1 Vertical or horizontal mounting position

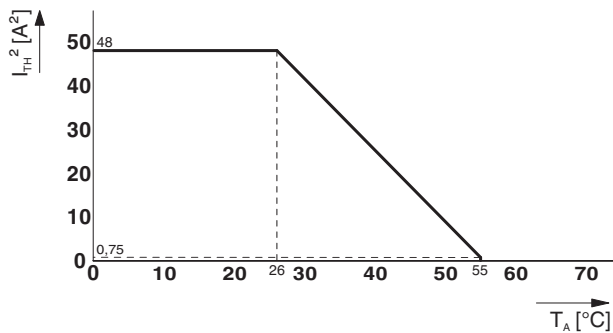

Figure 2 Derating curve - vertical or horizontal mounting position with connected modules

9 Function/time diagrams

Key:

Designation	Explanation
A1/A2	Power supply
S34	Start circuit
S12	Input sensor circuit
13/14, 23/24, 33/34	Undelayed enabling current paths
M1	Signal output (PNP)

9.1 Time diagram for automatic start

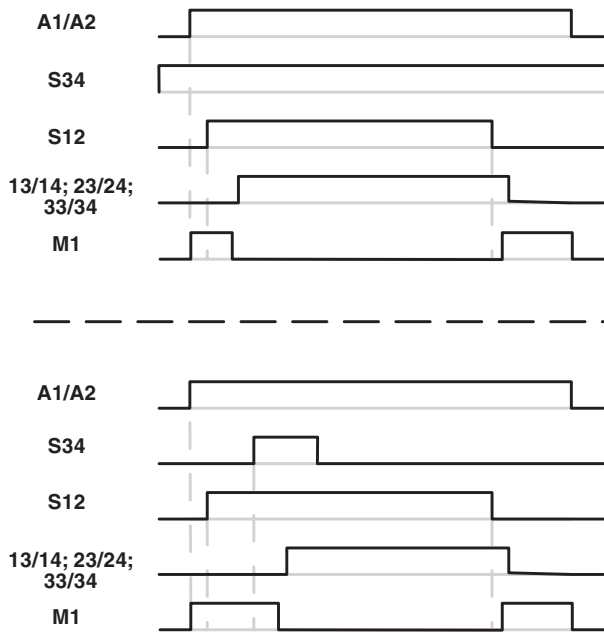

Figure 4 Time diagram for automatic start

9.2 Time diagram for manual, monitored start

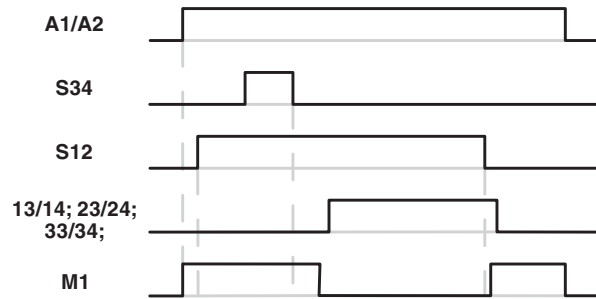

Figure 5 Time diagram for manual, monitored start

10 Operating and indication elements

10.1 Connection versions

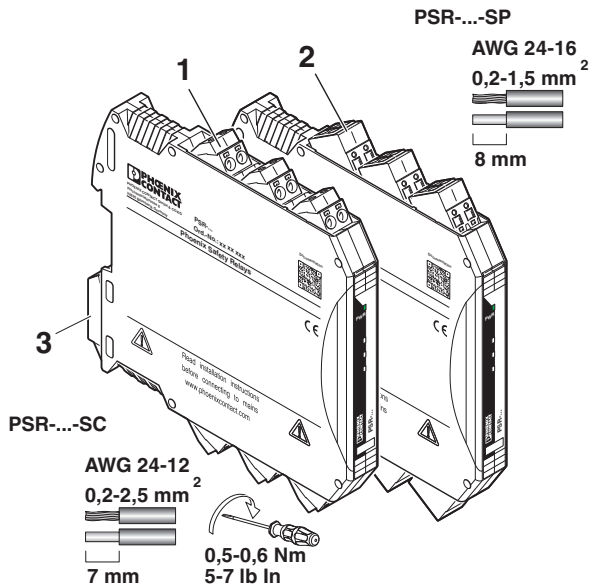

Figure 6 Connection versions

- 1 COMBICON plug-in screw terminal block
- 2 COMBICON plug-in spring-cage terminal block
- 3 Metal lock for fixing to DIN rail



The year the device was constructed can be found underneath the CE designation on the housing.

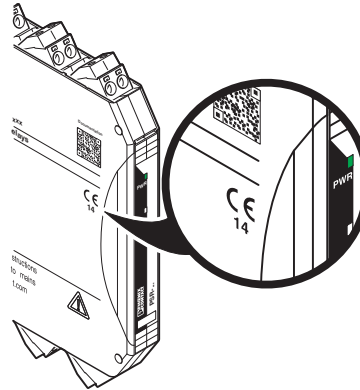

Figure 7 Year of manufacture of the device

10.2 Connection assignment

Figure	Designation	Explanation
	A1	+24 V power supply
	A2	0 V power supply
	M1	Signal output (PNP)
	S11	Output 24 V
	S12	Input sensor circuit
	PWR	Power LED (green)
	IN	Status indicator sensor circuit; LED (green)
	K1	Status indicator safety circuit; LED (green)
	K2	Status indicator safety circuit; LED (green)
	13/14	Undelayed enabling current paths
23/24		
33/34		

11 Mounting and connection

Mount the module on a 35 mm DIN rail according to EN 60715.

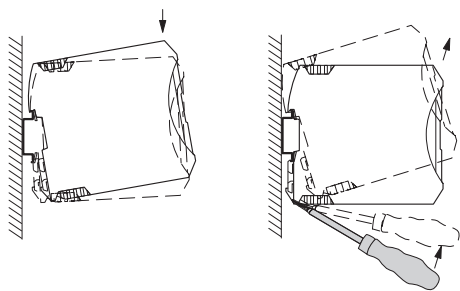

Figure 8 Mounting and removing

Connect the cables to the connection terminal blocks using a screwdriver.

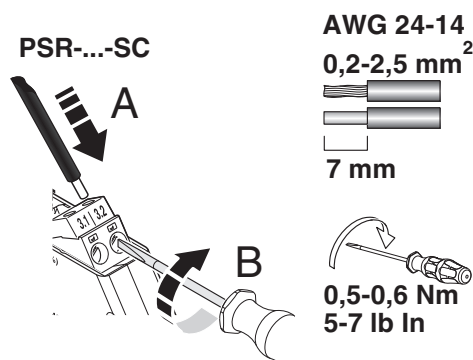

Figure 9 Connecting the cables for PSR-...-SC (screw terminal block)

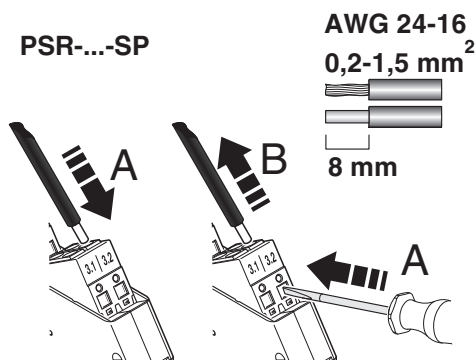

Figure 10 Connecting the cables for PSR-...-SC (spring-cage terminal block)



For compliance with UL approval, use copper wire that is approved up to 60°C/75°C.

12 Startup

Apply the rated control supply voltage (24 V DC) at terminal blocks A1/A2. The PWR LED lights up.

Close sensor circuit S11/S12. The IN LED lights up.

Automatic or manual, monitored start:

Close contacts S11/S34 as follows.

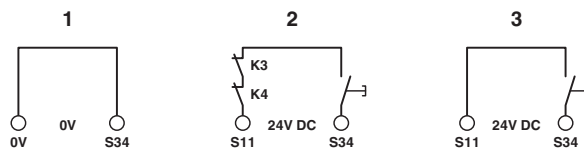

Figure 11 Connection of automatic or manual, monitored start

- 1 Automatic start
- 2 Manual, monitored start with monitored contact extension
- 3 Manual, monitored start

When automatic start is selected, the enabling current paths close.

For manual, monitored start, first press the reset button. The release of the button causes the enabling current paths to close.

The K1 and K2 LEDs light up.

When the supply voltage drops or the sensor circuit (S11/S12) is opened, the enabling current paths of the output circuits (13/14, 23/24, 33/34) open and the contacts enter the safe state.

13 Calculating the power dissipation



The total power dissipation of the safety relay is based on the input power dissipation and the contact power dissipation for the same and for different load currents.

Input power dissipation

$$P_{\text{Input}} = U_B^2 / (U_S / I_S)$$

Contact power dissipation

With the same load currents:

$$P_{\text{Contact}} = n \cdot I_L^2 \cdot 50 \text{ m}\Omega$$

With different load currents:

$$P_{\text{Contact}} = (I_{L1}^2 + I_{L2}^2 + \dots + I_{Ln}^2) \cdot 50 \text{ m}\Omega$$

Total power dissipation

$$P_{\text{Total}} = P_{\text{Input}} + P_{\text{Contact}}$$

therefore

$$P_{\text{Total}} = U_B^2 / (U_S / I_S) + n \cdot I_L^2 \cdot 50 \text{ m}\Omega$$

or

$$P_{\text{Total}} = U_B^2 / (U_S / I_S) + (I_{L1}^2 + I_{L2}^2 + \dots + I_{Ln}^2) \cdot 50 \text{ m}\Omega$$

Key:

Designation	Explanation
P	Power dissipation in mW
U_B	Applied operating voltage
U_S	Rated control supply voltage
I_S	Rated control supply current
n	Number of enabling current paths used
I_L	Contact load current

14 Diagnostics

Function test/proof test

The following section describes the LED indicators for general states and error messages as well as possible causes and remedies.



Use the function test to check the safety function. To do this, request the safety function once by pressing the emergency stop button, for example. Check whether the safety function is running correctly by switching the device on again via the sensor circuits.

14.1 General states

PWR LED	IN LED	K1 LED	K2 LED	State	Notes
ON	OFF	OFF	OFF	All relays are not activated. The sensor circuit is off.	Possible error see error messages
ON	ON	OFF	OFF	The sensor circuit is active. Relays K1 and K2 are ready to start and await reset/start command (S34).	-
ON	ON	ON	ON	The sensor circuit is active. All relays are picked up.	-

14.2 Error Messages

PWR LED	IN LED	K1 LED	K2 LED	State	Possible cause	Remedy
ON	OFF	OFF	OFF	The sensor circuit is actively controlled, but no input LEDs are lit up.	Interrupt in the sensor circuit or faulty signal generator.	Check the sensor circuit/signal generator. Then perform a function test.
ON	ON	OFF	OFF	The sensor circuit is active. The reset/start circuit (S34) is/was activated. The safety circuit (K1 and K2) is not picking up.	External error: the read-back contact (external actuator) is open in the reset circuit. Internal error: 1. The diagnostic contact is not working correctly. 2. An N/O contact is welded.	External error: check the actuator. Internal error: perform a power down reset with subsequent function test. If the error occurs again after the function test, replace the device.
ON	ON	OFF	OFF	The sensor circuit is active. The reset/start circuit (S34) is/was activated. The safety circuit (K1 and K2) is not picking up.	Error during manual reset S34 (stuck-at at the input).	Remove the error in the reset/start circuit. Then perform a function test.

PWR LED	IN LED	K1 LED	K2 LED	State	Possible cause	Remedy
ON	ON	OFF	ON	The sensor circuit is active. The reset/start circuit (S34) is/was activated. The safety circuit (K1) is not picking up.	Internal error. Diagnostics active.	Internal error: perform a power down reset with subsequent function test. If the error occurs again after the function test, replace the device.
ON	ON	ON	OFF	The sensor circuit is active. The reset/start circuit (S34) is/was activated. The safety circuit (K2) is not picking up.	Internal error. Diagnostics active.	Internal error: perform a power down reset with subsequent function test. If the error occurs again after the function test, replace the device.
OFF	OFF	OFF	OFF	The sensor circuit is active.	1. No supply voltage at A1/A 2. Over- or undervoltage at A1	Check the supply voltage.

15 Application examples

Key:

- S1 = Emergency stop button
- S2 = Manual reset device
- B1/B2 = Mechanical safety door switches
- K1/K2 = Contactors

Applications with the PSR-MC20

15.1 Emergency stop monitoring/automatic start

- Single-channel emergency stop monitoring
- Automatic start
- Monitoring of external contactors
- Suitable up to category 1, PL c (EN ISO 13849-1), SIL 1 (EN 62061)

i Contactor K2 is not essential in order to achieve category 1.

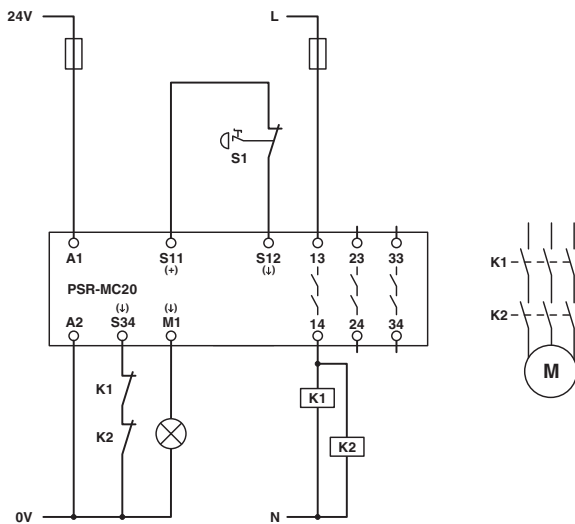

Figure 12 Emergency stop monitoring/automatic start

15.2 Emergency stop monitoring/manual, monitored start

- Single-channel emergency stop monitoring
- Manual, monitored start
- Monitoring of external contactors
- Suitable up to category 1, PL c (EN ISO 13849-1), SIL 1 (EN 62061)

i Contactor K2 is not essential in order to achieve category 1.

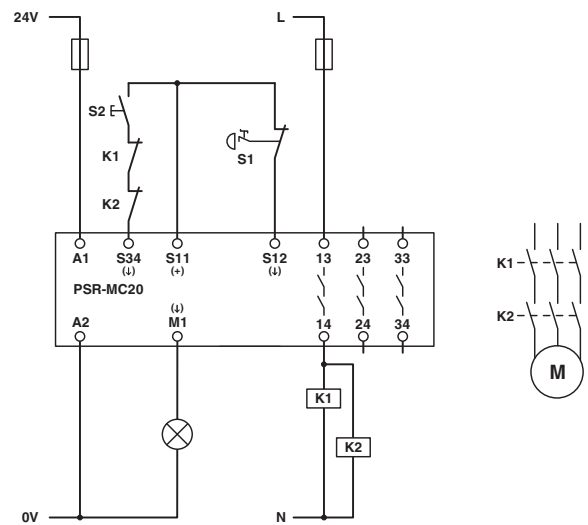

Figure 13 Emergency stop monitoring/manual, monitored start

15.3 Safety door monitoring/automatic start

- Single-channel safety door monitoring
- Automatic start
- Monitoring of external contactors
- Suitable up to category 1, PL c (EN ISO 13849-1), SIL 1 (EN 62061)



Contactor K2 is not essential in order to achieve category 1.

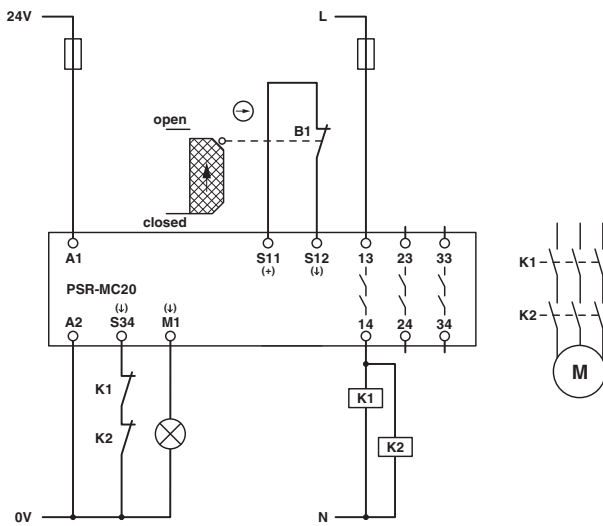

Figure 14 Safety door monitoring/automatic start

15.4 Safety door monitoring/manual, monitored start

- Single-channel safety door monitoring
- Manual, monitored start
- Monitoring of external contactors
- Suitable up to category 1, PL c (EN ISO 13849-1), SIL 1 (EN 62061)



Contactor K2 is not essential in order to achieve category 1.

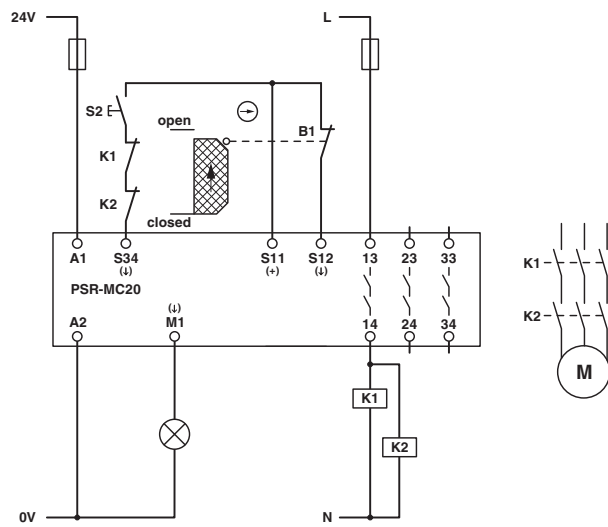

Figure 15 Safety door monitoring/manual, monitored start

15.5 Connection to failsafe controller/automatic start

- Automatic start
- Monitoring of external contactors
- Suitable up to category 4, PL e (EN ISO 13849-1), SIL 3 (EN 62061) if the digital output of the safety-related controller meets PL e, SIL 3 and cross-circuits can be ruled out



WARNING: Loss of functional safety!

Make sure that the signal generator (e.g., PLC output card or light grid) and the safety relay have the same ground potential.



Cross-circuits in the cable installation can be excluded if the failsafe PLC, safety relay, and external contactors K1 and K2 are located in the same electrical installation space.

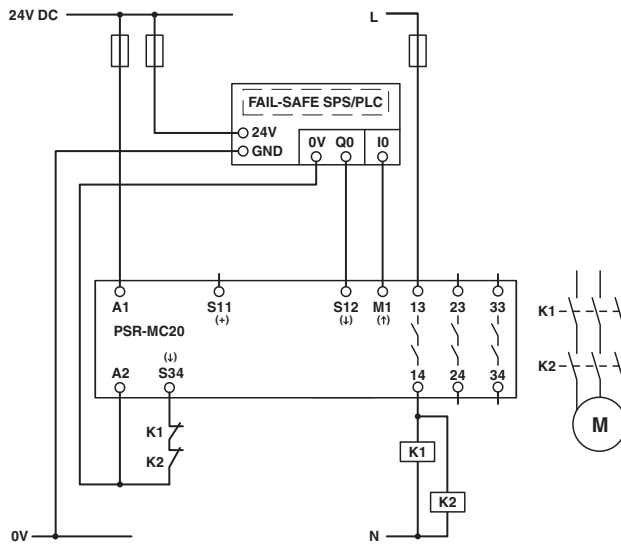

Figure 16 Connection to error-free PLC/automatic start

16 Revision history

Version	Date	Contents
00	2014-12-03	First publication
01	2015-03-05	Reverse polarity protection extended; relay type extended; dimensions updated; load curve extended
02	2015-04-09	Cat., PL, SIL, SILCL revised in technical data
03	2015-08-21	Input voltage range "0"-signal added; relay type changed; application examples and notes for the examples revised



Компания «ЭлектроПласт» предлагает заключение долгосрочных отношений при поставках импортных электронных компонентов на взаимовыгодных условиях!

Наши преимущества:

- Оперативные поставки широкого спектра электронных компонентов отечественного и импортного производства напрямую от производителей и с крупнейших мировых складов;
- Поставка более 17-ти миллионов наименований электронных компонентов;
- Поставка сложных, дефицитных, либо снятых с производства позиций;
- Оперативные сроки поставки под заказ (от 5 рабочих дней);
- Экспресс доставка в любую точку России;
- Техническая поддержка проекта, помощь в подборе аналогов, поставка прототипов;
- Система менеджмента качества сертифицирована по Международному стандарту ISO 9001;
- Лицензия ФСБ на осуществление работ с использованием сведений, составляющих государственную тайну;
- Поставка специализированных компонентов (Xilinx, Altera, Analog Devices, Intersil, Interpoint, Microsemi, Aeroflex, Peregrine, Syfer, Eurofarad, Texas Instrument, Miteq, Cobham, E2V, MA-COM, Hittite, Mini-Circuits, General Dynamics и др.);

Помимо этого, одним из направлений компании «ЭлектроПласт» является направление «Источники питания». Мы предлагаем Вам помощь Конструкторского отдела:

- Подбор оптимального решения, техническое обоснование при выборе компонента;
- Подбор аналогов;
- Консультации по применению компонента;
- Поставка образцов и прототипов;
- Техническая поддержка проекта;
- Защита от снятия компонента с производства.



Как с нами связаться

Телефон: 8 (812) 309 58 32 (многоканальный)

Факс: 8 (812) 320-02-42

Электронная почта: org@eplast1.ru

Адрес: 198099, г. Санкт-Петербург, ул. Калинина, дом 2, корпус 4, литера А.