

High Reliability Reflective Object Sensor

OPB700TX, OPB700TXV



Features:

- Non-contact switching
- Low profile to facilitate stacking
- Hermetically sealed components
- 24" (609.60 mm) minimum length wire conforms to MIL-W-16878
- TX and TXV components processed to MIL-PRF-19500



Description:

Each **OPB700TX** and **OPB700TXV** sensor consists of a gallium aluminum arsenide LED and a silicon phototransistor mounted side-by-side on converging optical axes in a high-temperature black plastic housing. The phototransistor responds to the radiation from the LED only when a reflective object passes within its field of view. Lead wires are #26 AWG polytetrafluoroethylene (PTFE) insulated, which conforms to MIL-W-16878.

TX and TXV device components are processed to OPTEK's military screening program patterned after MIL-PRF-19500.

Please refer to Application Bulletins 208 and 210 for additional design information and reliability (degradation) data.

Contact your local representative or OPTEK for more information.

Applications:

- Non-contact reflective object sensor
- Assembly line automation
- Machine automation
- Machine safety
- End of travel sensor
- Door sensor

Part Number	LED Peak Wavelength	Sensor	Reflection Distance Inch (mm)	I _{C(ON)} (mA) Min	I _F (mA) Typ / Max	V _{CE} (Volts) Max	Lead Length / Spacing
OPB700TX	890 nm	Transistor	0.200" (5.08 mm)	0.03	40 / 50	50	24" 26 AWG Wire
OPB700TXV							

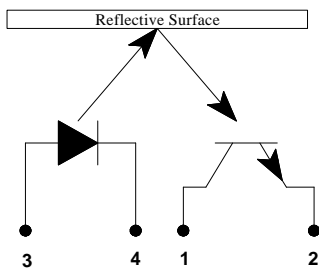

Color/Pin #	LED	Color/Pin #	LED
Orange-3	Anode	White-1	Collector
Green-4	Cathode	Blue-2	Emitter

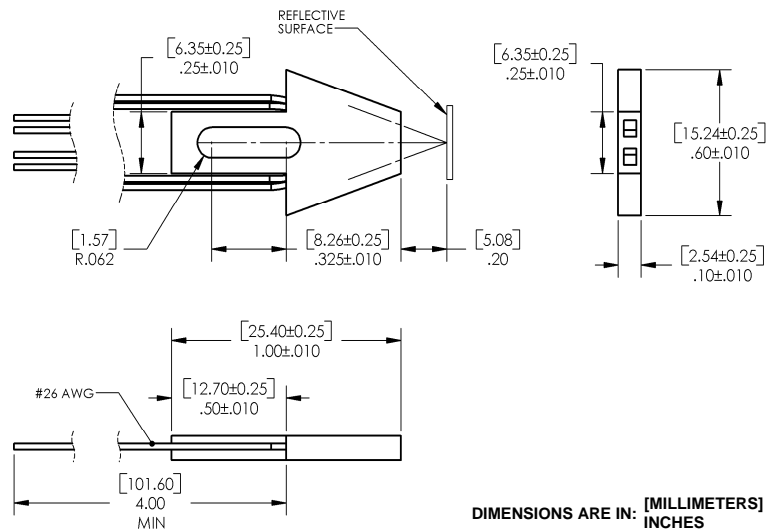

DIMENSIONS ARE IN: [MILLIMETERS] INCHES

General Note
TT Electronics reserves the right to make changes in product specification without notice or liability. All information is subject to TT Electronics' own data and is considered accurate at time of going to print.

OPTEK Technology, Inc.
1645 Wallace Drive, Carrollton, TX 75006 | Ph: +1 972 323 2200
www.optekinc.com | www.ttelectronics.com

High Reliability Reflective Object Sensor

OPB700TX, OPB700TXV



Absolute Maximum Ratings ($T_A=25^\circ\text{C}$ unless otherwise noted)

Storage Temperature Range	-65° C to + 150° C
Operating Temperature Range	-65° C to + 125° C
Lead Soldering Temperature	260° C

Input Diode

Forward DC Current	50 mA
Reverse Voltage	2 V
Power Dissipation ⁽¹⁾	100 mW

Output Phototransistor

Collector-Emitter Voltage	50 V
Emitter-Collector Voltage	7 V
Power Dissipation ⁽¹⁾	100 mW

Electrical Characteristics ($T_A = 25^\circ\text{C}$ unless otherwise noted)

SYMBOL	PARAMETER	MIN	TYP	MAX	UNITS	TEST CONDITIONS
--------	-----------	-----	-----	-----	-------	-----------------

Input Diode

V_F	Forward Voltage ⁽⁶⁾	1.1	1.6	1.8	V	$I_F = 50 \text{ mA}$
		1.3	1.8	2.0		$I_F = 50 \text{ mA}, T_A = -55^\circ \text{ C}$
		0.9	1.4	1.7		$I_F = 50 \text{ mA}, T_A = 100^\circ \text{ C}$
I_R	Reverse Current	-	0.1	100	μA	$V_R = 2 \text{ V}$

Output Phototransistor

$V_{(BR)CEO}$	Collector-Emitter Breakdown Voltage	50	110	-	V	$I_C = 1 \text{ mA}, I_F = 0$
$V_{(BR)ECO}$	Emitter-Collector Breakdown Voltage	7	10	-	V	$I_E = 100 \mu\text{A}, I_F = 0$
$I_{C(OFF)}$	Collector-Emitter Dark Current	-	-	100	nA	$V_{CE} = 10 \text{ V}, I_F = 0$
		-	10	100	μA	$V_{CE} = 10 \text{ V}, I_F = 0, T_A = 100^\circ \text{ C}$

General Note
TT Electronics reserves the right to make changes in product specification without notice or liability. All information is subject to TT Electronics' own data and is considered accurate at time of going to print.

OPTEK Technology, Inc.
1645 Wallace Drive, Carrollton, TX 75006 | Ph: +1 972 323 2200
www.optekinc.com | www.ttelectronics.com

High Reliability Reflective Object Sensor

OPB700TX, OPB700TXV



Electrical Characteristics (T_A = 25°C unless otherwise noted)

SYMBOL	PARAMETER	MIN	TYP	MAX	UNITS	TEST CONDITIONS
--------	-----------	-----	-----	-----	-------	-----------------

Output Phototransistor

I _{C(ON)}	On-State Collector Current d = 0.20" (5.08 mm) ⁽²⁾⁽³⁾⁽⁶⁾	50	200	-	μA	V _{CE} = 5 V, I _F = 40 mA
		25	-	-		V _{CE} = 5 V, I _F = 40 mA, T _A = -55° C
		25	-	-		V _{CE} = 5 V, I _F = 40 mA, T _A = 100° C
I _{CX}	Crosstalk (No reflective surface) ⁽³⁾	-	2	-	μA	V _{CE} = 5 V, I _F = 40 mA
V _{CE(SAT)}	Collector-Emitter Saturation Voltage d = 0.20" (5.08 mm) ⁽²⁾⁽³⁾	-	-	0.4	V	I _C = 10 μA, I _F = 40 mA
t _r	Output Rise Time	-	12	20	μs	V _{CC} = 10 V, I _F = 20 mA, R _L = 1,000 Ω
t _f	Output Fall Time	-	12	20		

Notes:

- Derate linearly 1.00 mW/°C above 25 ° C.
- Measured using Eastman Kodak neutral white test card with 90% diffuse reflectance as a reflective surface.
- Crosstalk (I_{CX}) is the collector current measured with the indicated current in the input diode and no reflective surface.
- The distance from the assembly head to the reflective surface is "d".
- Methanol or isopropyl alcohol is recommended as a cleaning agent.
- Measurement is taken during the last 500 μs of a single 1.0 ms test phase. Heating due to increment pulse rate or pulse width can cause change in measurement results.

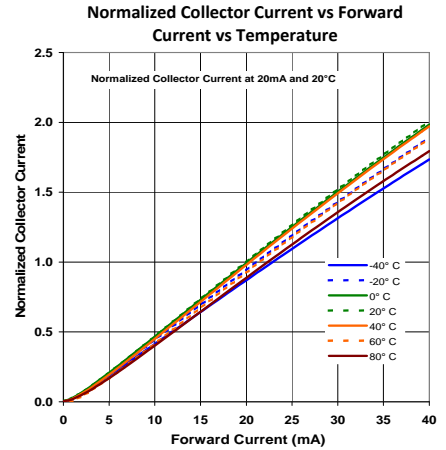
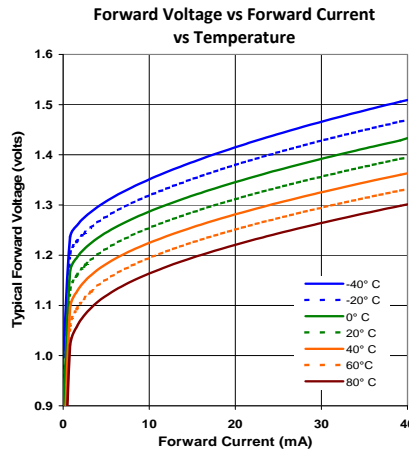
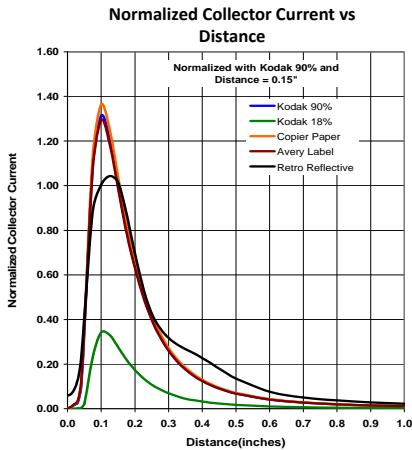

General Note
TT Electronics reserves the right to make changes in product specification without notice or liability. All information is subject to TT Electronics' own data and is considered accurate at time of going to print.

OPTEK Technology, Inc.
1645 Wallace Drive, Carrollton, TX 75006 | Ph: +1 972 323 2200
www.optekinc.com | www.ttelectronics.com



Компания «ЭлектроПласт» предлагает заключение долгосрочных отношений при поставках импортных электронных компонентов на взаимовыгодных условиях!

Наши преимущества:

- Оперативные поставки широкого спектра электронных компонентов отечественного и импортного производства напрямую от производителей и с крупнейших мировых складов;
- Поставка более 17-ти миллионов наименований электронных компонентов;
- Поставка сложных, дефицитных, либо снятых с производства позиций;
- Оперативные сроки поставки под заказ (от 5 рабочих дней);
- Экспресс доставка в любую точку России;
- Техническая поддержка проекта, помощь в подборе аналогов, поставка прототипов;
- Система менеджмента качества сертифицирована по Международному стандарту ISO 9001;
- Лицензия ФСБ на осуществление работ с использованием сведений, составляющих государственную тайну;
- Поставка специализированных компонентов (Xilinx, Altera, Analog Devices, Intersil, Interpoint, Microsemi, Aeroflex, Peregrine, Syfer, Eurofarad, Texas Instrument, Miteq, Cobham, E2V, MA-COM, Hittite, Mini-Circuits, General Dynamics и др.);

Помимо этого, одним из направлений компании «ЭлектроПласт» является направление «Источники питания». Мы предлагаем Вам помощь Конструкторского отдела:

- Подбор оптимального решения, техническое обоснование при выборе компонента;
- Подбор аналогов;
- Консультации по применению компонента;
- Поставка образцов и прототипов;
- Техническая поддержка проекта;
- Защита от снятия компонента с производства.



Как с нами связаться

Телефон: 8 (812) 309 58 32 (многоканальный)

Факс: 8 (812) 320-02-42

Электронная почта: org@eplast1.ru

Адрес: 198099, г. Санкт-Петербург, ул. Калинина, дом 2, корпус 4, литера А.