



Main

Product or component type	Biometric switch
Product specific application	Industrial machines Materials handling
Device short name	XB5S
Bezel material	Plastic
Mounting diameter	0.87 in (22 mm)
Output type	PNP
Sale per indivisible quantity	1
IP degree of protection	IP65 front face conforming to EN/IEC 60529 IP20 rear face conforming to EN/IEC 60529
Type of operator	Momentary
Operator profile	Fingerprint reader
Connections - terminals	1 pre-wired cable, clamping capacity: 3 x 0.11 mm ²
Memory usage	200 users with up to 2 fingerprints per user

Complementary

Software designation	XB5SSoft
Enclosure material	Polyamide PA66
Cable insulation material	PvR
Operating position	Flat surface installation Horizontal position Vertical surface installation
Function of module	Monostable
Product weight	0.45 lb(US) (0.202 kg)
Marking	CE
Communication port protocol	USB
Connector type	USB type A male with 3.28 ft (1 m) cable
Local signalling	1 LED green, function: output state indicator 1 LED red, function: error
Short-circuit protection	250 mA by gG external fuse
[Us] rated supply voltage	24 V DC
Electrical connection	Free wire ends with 3 wires of 6.56 ft (2 m)
Supply voltage limits	20...30 V DC
Protection type	Overload protection Reverse polarity Short-circuit
Maximum switching current	200 mA
[Ures] residual voltage	1 V, closed state
Current consumption	<= 70 mA no-load
Delay first up	<= 3 s + 0.5 ms per user registered
Delay recovery	<= 1.5 s
Delay response	<= 1.5 s

Environment

range of product	Harmony XB5S
ambient air temperature for storage	-13...158 °F (-25...70 °C)
ambient air temperature for operation	23...122 °F (-5...50 °C)
NEMA degree of protection	NEMA 12
standards	IEC 61000-6-2

The information provided in this documentation contains general descriptions and/or technical characteristics of the products contained herein. This documentation is not intended as a substitute for and is not to be used for determining suitability or reliability of these products for specific user applications. It is the duty of any such user or integrator to perform the appropriate and complete risk analysis, evaluation and testing of the products with respect to the relevant specific application or use thereof. Neither Schneider Electric Industries SAS nor any of its affiliates or subsidiaries shall be responsible or liable for misuse of the information contained herein.

product certifications	CSA UL
vibration resistance	+/- 3 mm (f = 5...9 Hz) conforming to IEC 60068-2-6 1 gn (f = 9...500 Hz) conforming to IEC 60068-2-6
shock resistance	50 gn 11 ms conforming to IEC 60068-2-27

Offer Sustainability

Not Green Premium product	Not Green Premium product
Compliant - since 0844 - Schneider Electric declaration of conformity	Compliant - since 0844 - Schneider Electric declaration of conformity
Reference not containing SVHC above the threshold	Reference not containing SVHC above the threshold
Available	Available
WARNING: This product can expose you to chemicals including:	WARNING: This product can expose you to chemicals including:
Lead and lead compounds, which is known to the State of California to cause cancer and birth defects or other reproductive harm.	Lead and lead compounds, which is known to the State of California to cause cancer and birth defects or other reproductive harm.
For more information go to www.p65warnings.ca.gov	For more information go to www.p65warnings.ca.gov

Contractual warranty

Warranty period	18 months
-----------------	-----------

Dimensions of Biometric Switches

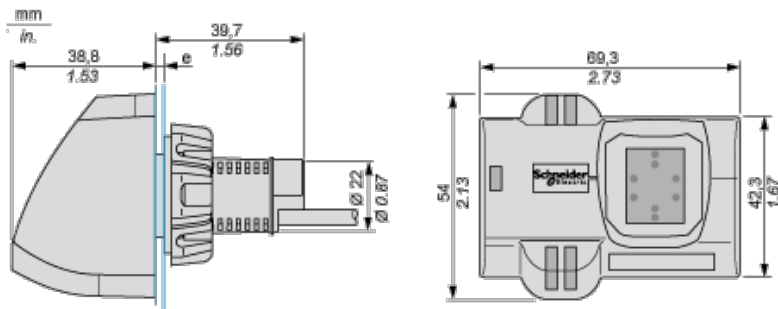

e: 1 to 6 mm / 0.04 to 0.24 in.

Cable with PNP Output



BU: Blue

BN: Brown

BK: Black



Компания «ЭлектроПласт» предлагает заключение долгосрочных отношений при поставках импортных электронных компонентов на взаимовыгодных условиях!

Наши преимущества:

- Оперативные поставки широкого спектра электронных компонентов отечественного и импортного производства напрямую от производителей и с крупнейших мировых складов;
- Поставка более 17-ти миллионов наименований электронных компонентов;
- Поставка сложных, дефицитных, либо снятых с производства позиций;
- Оперативные сроки поставки под заказ (от 5 рабочих дней);
- Экспресс доставка в любую точку России;
- Техническая поддержка проекта, помощь в подборе аналогов, поставка прототипов;
- Система менеджмента качества сертифицирована по Международному стандарту ISO 9001;
- Лицензия ФСБ на осуществление работ с использованием сведений, составляющих государственную тайну;
- Поставка специализированных компонентов (Xilinx, Altera, Analog Devices, Intersil, Interpoint, Microsemi, Aeroflex, Peregrine, Syfer, Eurofarad, Texas Instrument, Miteq, Cobham, E2V, MA-COM, Hittite, Mini-Circuits, General Dynamics и др.);

Помимо этого, одним из направлений компании «ЭлектроПласт» является направление «Источники питания». Мы предлагаем Вам помощь Конструкторского отдела:

- Подбор оптимального решения, техническое обоснование при выборе компонента;
- Подбор аналогов;
- Консультации по применению компонента;
- Поставка образцов и прототипов;
- Техническая поддержка проекта;
- Защита от снятия компонента с производства.



Как с нами связаться

Телефон: 8 (812) 309 58 32 (многоканальный)

Факс: 8 (812) 320-02-42

Электронная почта: org@eplast1.ru

Адрес: 198099, г. Санкт-Петербург, ул. Калинина, дом 2, корпус 4, литера А.