

9-Bit/12-Bit Temperature Sensors with I²C-Compatible Serial Interface in a SOT23

General Description

The MAX6625/MAX6626 combine a temperature sensor, a programmable overtemperature alarm, and an I²C-compatible serial interface into single compact packages. They convert their die temperatures into digital values using internal analog-to-digital converters (ADCs). The result of the conversion is held in a temperature register, readable at any time through the serial interface. A dedicated alarm output, OT, activates if the conversion result exceeds the value programmed in the high-temperature register. A programmable fault queue sets the number of faults that must occur before the alarm activates, preventing spurious alarms in noisy environments. OT has programmable output polarity and operating modes.

The MAX6625/MAX6626 feature a shutdown mode that saves power by turning off everything but the power-on reset and the I²C-compatible interface. Four separate addresses can be configured with the ADD pin, allowing up to four MAX6625/MAX6626 devices to be placed on the same bus. The MAX6625P/MAX6626P OT outputs are open drain, and the MAX6625R/MAX6626R OT outputs include internal pullup resistors.

The MAX6625 has a 9-bit internal ADC and can function as a replacement for the LM75 in most applications. The MAX6626 has a 12-bit internal ADC. Both devices come in the space-saving 6-pin SOT23 package, or the 6-pin TDFN package.

Applications

Fan Control
 Temperature Alarms
 System Temperature Control
 Industrial Equipment

Pin Configuration

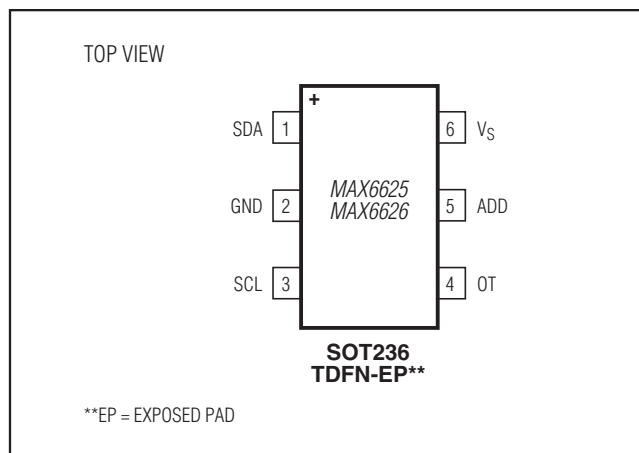

Features

- ◆ 9-Bit Temperature-to-Digital Converter (MAX6625)
- ◆ 12-Bit Temperature-to-Digital Converter (MAX6626)
- ◆ I²C-Compatible Serial Interface
- ◆ Up to Four Devices on a Single Bus
- ◆ Versatile Alarm Output with Programmable Trip Temperature and Hysteresis
- ◆ Low-Power Shutdown Mode
- ◆ Space-Saving TDFN or SOT23 Packages
- ◆ Lead-Free Version Available (TDFN Package)

Ordering Information

PART	TEMP RANGE	PIN-PACKAGE
MAX6625PMUT*	-55°C to +125°C	6 SOT23
MAX6625RMUT*	-55°C to +125°C	6 SOT23
MAX6625PMTT*	-55°C to +125°C	6 TDFN-EP**
MAX6625RMTT*	-55°C to +125°C	6 TDFN-EP**
MAX6626PMUT*	-55°C to +125°C	6 SOT23
MAX6626RMUT*	-55°C to +125°C	6 SOT23
MAX6626PMTT*	-55°C to +125°C	6 TDFN-EP**
MAX6626RMTT*	-55°C to +125°C	6 TDFN-EP**

*For device options, see Selector Guide at end of data sheet. Requires special solder temperature profile described in the Absolute Maximum Ratings section.

**EP = Exposed pad.

Typical Operating Circuit

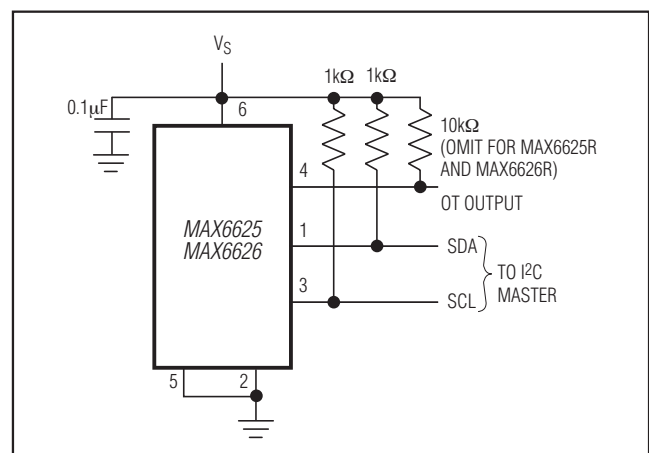

For pricing, delivery, and ordering information, please contact Maxim Direct at 1-888-629-4642, or visit Maxim's website at www.maximintegrated.com.

MAX6625/MAX6626

9-Bit/12-Bit Temperature Sensors with I²C-Compatible Serial Interface in a SOT23

ABSOLUTE MAXIMUM RATINGS

V _S to GND	-0.3V to +6V
OT, SCL, SDA to GND	-0.3V to +6V
ADD to GND	-0.3V to (V _S + 0.3V)
Current into Any Pin.....	±5mA
OT Sink Current.....	20mA

Continuous Power Dissipation	
6-Pin SOT23 (derate 9.1mW/°C above +70°C).....	727mW
6-Pin TDFN (derate 23.8mW/°C above +70°C)	1905mW
Junction Temperature	+150°C
Storage Temperature Range	-60°C to +150°C
ESD Rating (Human Body Model).....	2000V
Lead Temperature	Note 1

Note 1: This device is constructed using a unique set of packaging techniques that impose a limit on the thermal profile the device can be exposed to during board-level solder attach and rework. This limit permits only the use of the solder profiles recommended in the industry-standard specification, IPC/JEDEC J-STD-020A, paragraph 7.6, Table 3 for IR/VPR and Convection Reflow. Preheating is required. Hand or wave soldering is not allowed.

Stresses beyond those listed under "Absolute Maximum Ratings" may cause permanent damage to the device. These are stress ratings only, and functional operation of the device at these or any other conditions beyond those indicated in the operational sections of the specifications is not implied. Exposure to absolute maximum rating conditions for extended periods may affect device reliability.

ELECTRICAL CHARACTERISTICS

(+3V ≤ V_S ≤ +5.5V, T_A = -55°C to +125°C, unless otherwise noted.)

PARAMETER	SYMBOL	CONDITIONS	MIN	TYP	MAX	UNITS
Power-Supply Voltage	V _S		3.0		5.5	V
Quiescent Current	I _C	I ² C-compatible active			1	mA
		I ² C-compatible inactive		250		μA
		Shutdown mode			1	
ADC Resolution		MAX6625		9		Bits
		MAX6626		12		
Temperature Resolution		MAX6625		0.5		°C/LSB
		MAX6626		0.0625		
Accuracy (Notes 2, 3)		T _A = +25°C, V _S = +3V to +3.6V			±1	°C
		0°C = T _A ≤ +50°C, V _S = +3.0V to +3.6V			±1.5	
		0°C = T _A ≤ +70°C, V _S = +3.0V to +3.6V			±2.0	
Power-Supply Sensitivity		V _S = +3V to +5.5V		1		°C/V
Conversion Time	t _C			133		ms
OT Pullup Resistor	R _P	MAX6625R, MAX6626R only	25		50	kΩ
OT Saturation Voltage (Note 4)	V _L	I _{OUT} = 4mA (Note 4)			0.8	V
OT Delay		(Programmable through fault queue)	1 × t _C		6 × t _C	ms
T _{HIGH} Default Temperature	T _{HIGH}			80		°C
T _{LOW} Default Temperature	T _{LOW}			75		°C
I²C-COMPATIBLE I/O: SCL, SDA, ADD						
Input High Voltage	V _{IH}	V _S < +3.6V	2			V
		V _S > +3.6V	3			
Input Low Voltage	V _{IL}				0.8	V
Input Hysteresis				0.2		V

MAX6625/MAX6626

9-Bit/12-Bit Temperature Sensors with I²C-Compatible Serial Interface in a SOT23

ELECTRICAL CHARACTERISTICS (continued)

(+3V ≤ V_S ≤ +5.5V, T_A = -55°C to +125°C, unless otherwise noted.)

PARAMETER	SYMBOL	CONDITIONS	MIN	TYP	MAX	UNITS
Input High Leakage Current	I _{IH}	V _{IN} = +5V			±1	μA
Input Low Leakage Current	I _{IL}	V _{IN} = 0			±1	μA
Input Capacitance	C _{IN}			10		pF
Output Low Voltage	V _{OL}	I _{OL} = 3mA			0.4	V
Output High Current	I _{OH}	V _{OH} = 5V			1	μA
I²C-COMPATIBLE TIMING						
Serial Clock Frequency	f _{SCL}		DC		400	kHz
Bus Free Time Between STOP and START Conditions	t _{BUF}		1.3			μs
START Condition Hold Time	t _{HD:STA}		0.6			μs
STOP Condition Setup Time	t _{SU:STO}		0.6			μs
Clock Low Period	t _{LOW}		1.3			μs
Clock High Period	t _{HIGH}		0.6			μs
Data Setup Time	t _{SU:DAT}		100			ns
Data Hold Time	t _{HD:DAT}	(Note 5)	0		0.9	μs
Maximum Receive SCL/SDA Rise Time	t _R	(Note 6)		300		ns
Minimum Receive SCL/SDA Rise Time	t _R	(Note 6)		20 + 0.1C _B		ns
Maximum Receive SCL/SDA Fall Time	t _F	(Note 6)		300		ns
Minimum Receive SCL/SDA Fall Time	t _F	(Note 6)		20 + 0.1C _B		ns
Transmit SDA Fall Time	t _F	C _B = 400pF, I _O = 3mA (Note 6)	20 + 0.1C _B		250	ns
Pulse Width of Suppressed Spike	t _{SP}	(Note 7)		50		ns

Note 2: Guaranteed by design and characterization to ±5 sigma.

Note 3: Quantization error not included in specifications for temperature accuracy.

Note 4: Output current should be minimized for best temperature accuracy. Power dissipation within the MAX6625/MAX6626 causes self-heating and temperature drift; see the *Thermal Considerations* section.

Note 5: A master device must provide a hold time of at least 300ns for the SDA signal in order to bridge the undefined region of SCL's falling edge.

Note 6: C_B = total capacitance of one bus line in pF. Tested with C_B = 400pF.

Note 7: Input filters on SDA, SCL, and ADD suppress noise spikes less than 50ns.

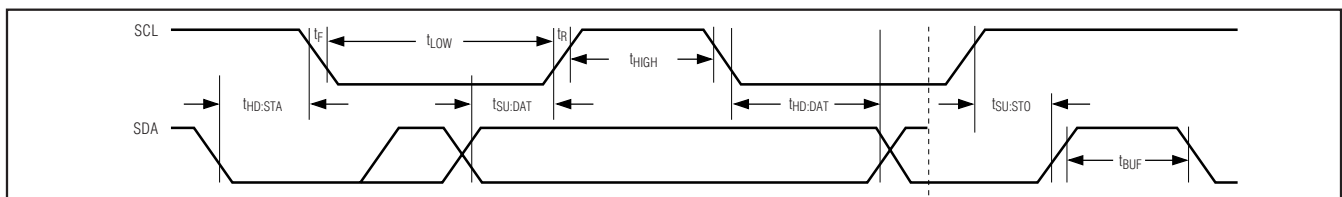

Figure 1. Serial Bus Timing

MAX6625/MAX6626

9-Bit/12-Bit Temperature Sensors with I²C-Compatible Serial Interface in a SOT23

Typical Operating Characteristics

(V_S = +3.3V, T_A = +25°C, unless otherwise noted.)

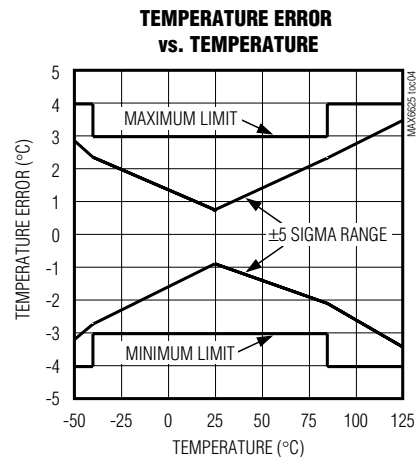
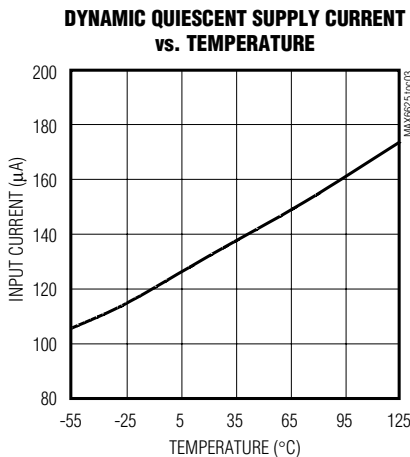
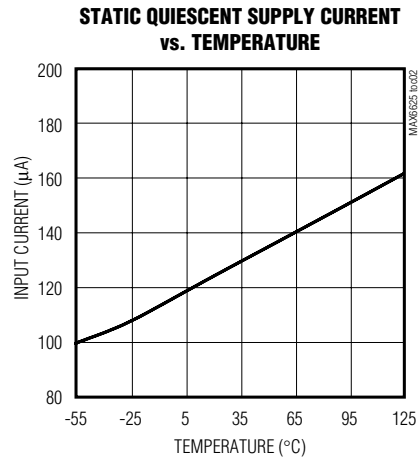
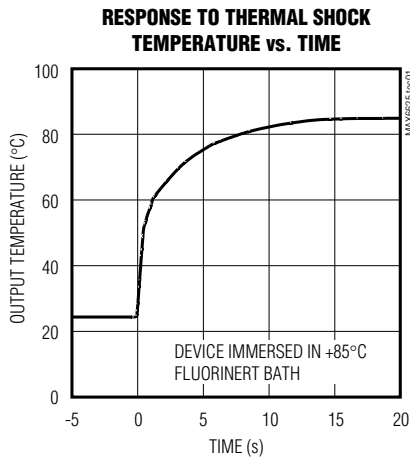

Pin Description

PIN	NAME	FUNCTION
1	SDA	I ² C-Compatible Serial Bidirectional Data Line
2	GND	Power-Supply Ground
3	SCL	I ² C-Compatible Clock Input
4	OT	Temperature Alarm Output
5	ADD	I ² C-Compatible Address Set Pin: Ground (0), V _S (1), SDA (2), SCL (3); see Table 1.
6	V _S	Power-Supply Input, +3V to +5.5V. Bypass V _S to GND with a 0.1µF capacitor.
—	EP	Exposed Paddle. Internally connected to GND. Connect to a large ground plane for maximum thermal dissipation.

MAX6625/MAX6626

9-Bit/12-Bit Temperature Sensors with I²C-Compatible Serial Interface in a SOT23

Detailed Description

The MAX6625/MAX6626 continuously convert their die temperatures into digital values using their self-contained delta-sigma ADCs. The resulting data is readable at any time through the I²C-compatible serial interface. A dedicated alarm output asserts if the result exceeds the value in the programmable high-temperature register. A programmable fault queue sets the number of faults that must occur before the alarm asserts, preventing spurious alarms in noisy environments. The alarm output polarity is selectable and deasserts based on either of two operating modes, comparator or interrupt. In comparator mode, the OT output deasserts if the temperature conversion result falls below the programmable low-temperature register value (subject to the fault queue conditions) providing adjustable hysteresis. In interrupt mode, the OT output deasserts when any register is read through the serial interface. Each conversion cycle takes about 130ms. At power-up, the temperature register is set to 8000h until the first conversion is completed.

The MAX6625/MAX6626 feature a shutdown mode, accessible through the serial interface, that saves power by turning off everything but the power-on reset and the I²C-compatible interface. While in shutdown mode, the temperature register is set to 8000h. The device func-

tions as a slave on the I²C-compatible bus supporting Write Byte, Write Word, Read Byte, and Read Word commands. Four separate addresses can be configured with the ADD pin, allowing up to four MAX6625/MAX6626 devices to be placed on the same bus. Figure 2 shows the functional diagram of the MAX6625/MAX6626.

Serial interface

I²C-Compatible Operation

The MAX6625/MAX6626 are readable and programmable through their I²C-compatible serial interface. Figures 3 and 4 show the timing details of the clock (SCL) and data (SDA) signals. The device functions as a slave on the I²C-compatible bus and supports Write Byte, Write Word, Read Byte, and Read Word commands.

Addressing

Four separate addresses can be configured with the ADD pin, allowing up to four MAX6625/MAX6626s to be placed on the same bus. The address is selected by connecting the ADD pin to either of four places: GND (address 0), V_S (address 1), SDA (address 2), or SCL (address 3). Table 1 shows the full I²C-compatible address for each state.

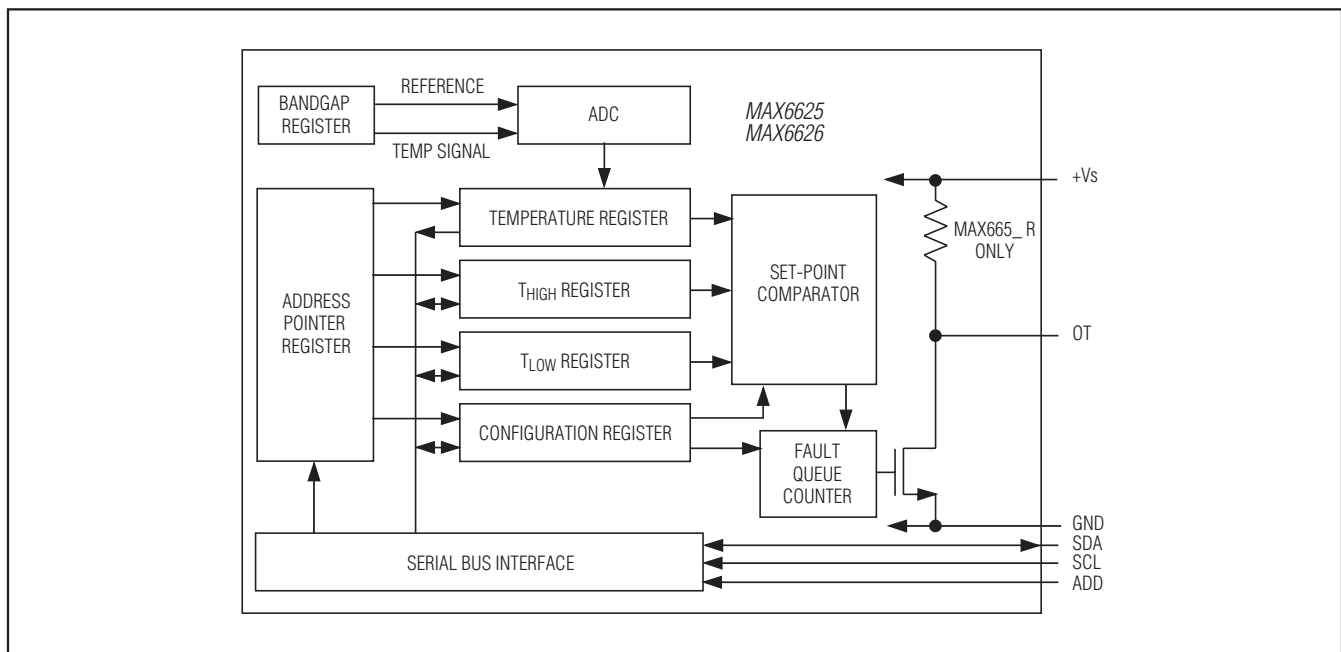

Figure 2. Functional Diagram

MAX6625/MAX6626

9-Bit/12-Bit Temperature Sensors with I²C-Compatible Serial Interface in a SOT23

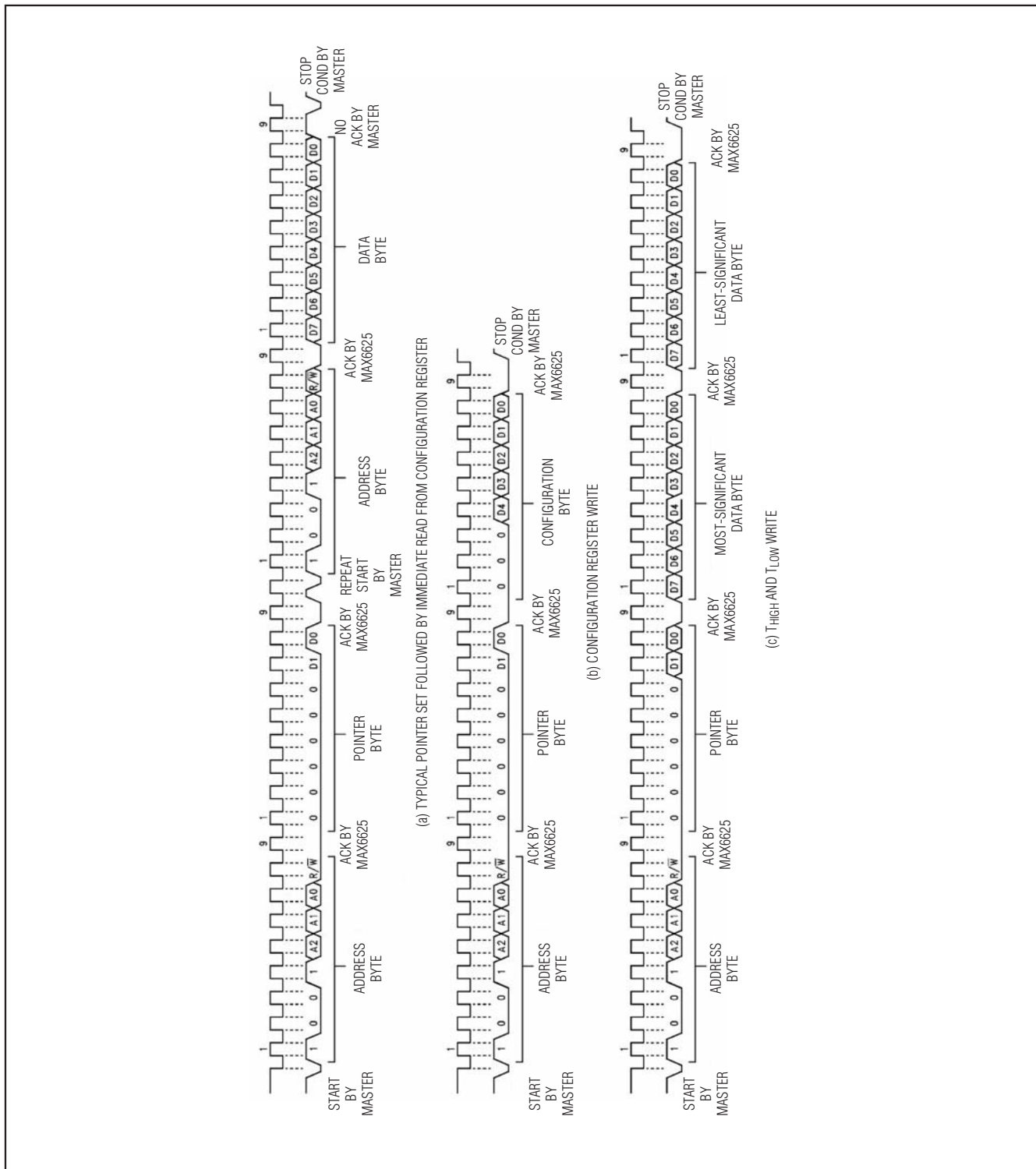

Figure 3. I²C-Compatible Timing Diagram

MAX6625/MAX6626

9-Bit/12-Bit Temperature Sensors with I²C-Compatible Serial Interface in a SOT23

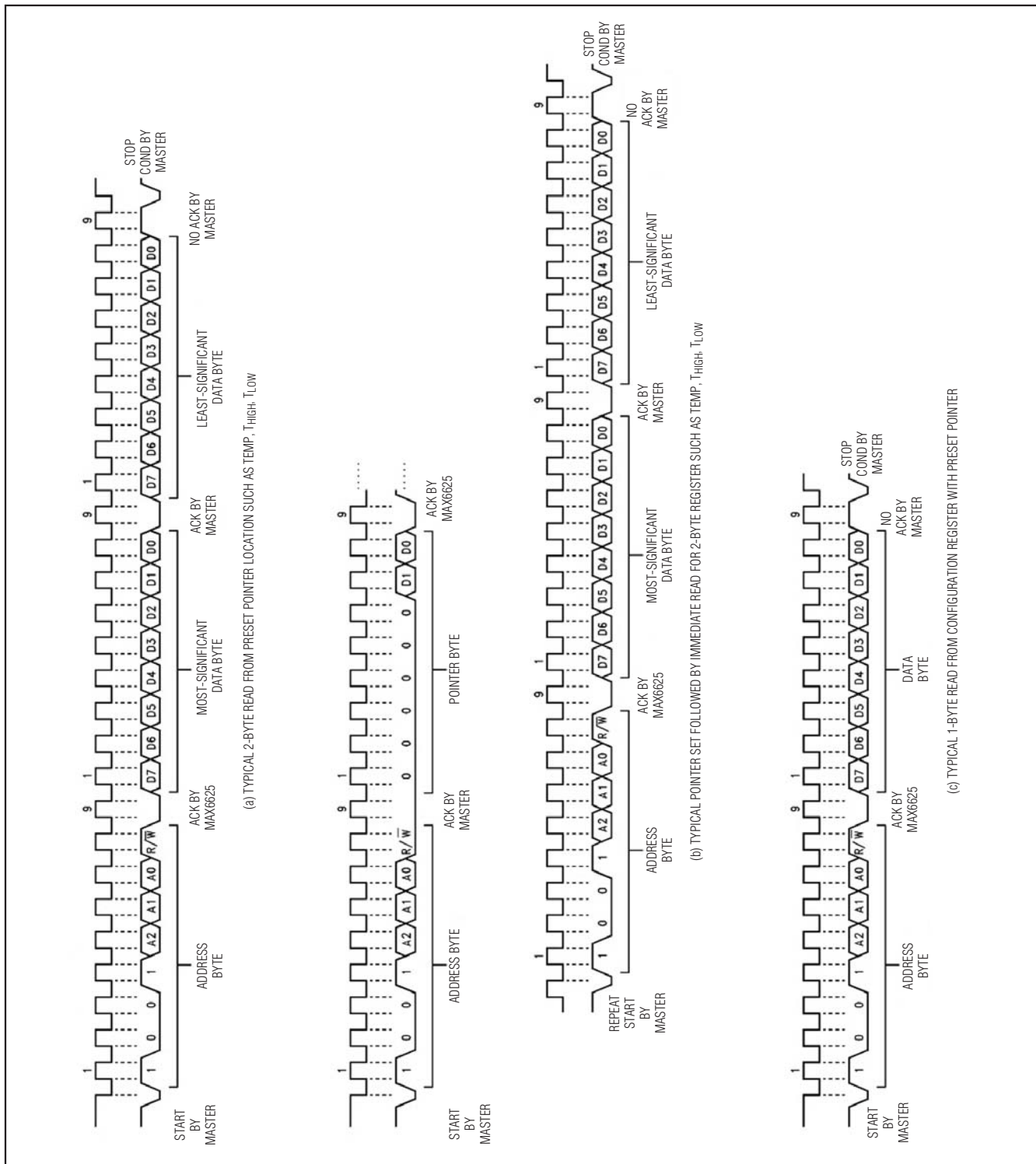

Figure 4. I²C-Compatible Timing Diagram

MAX6625/MAX6626

9-Bit/12-Bit Temperature Sensors with I²C-Compatible Serial Interface in a SOT23

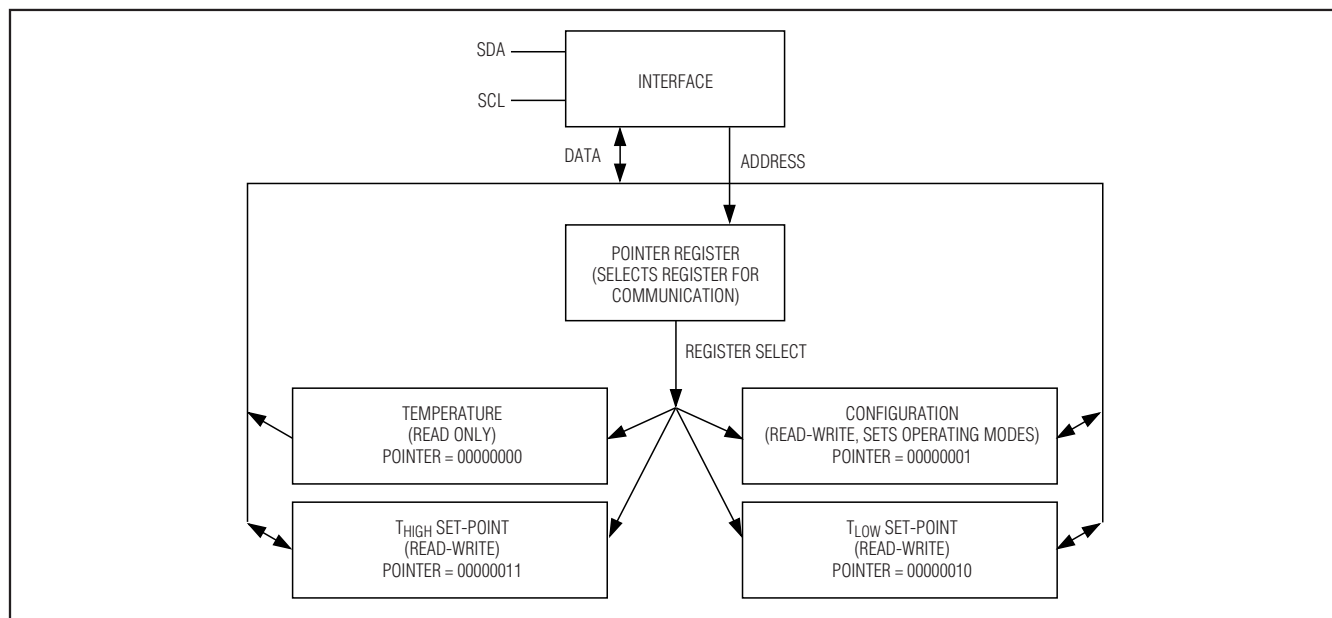

Figure 5. MAX6625/MAX6626 Programmable Model

Table 1. Address Selection

ADD CONNECTION	I ² C-COMPATIBLE ADDRESS
GND	100 1000
V _s	100 1001
SDA	100 1010
SCL	100 1011

Control Registers

Five registers control the operation of the MAX6625/MAX6626 (Figure 5 and Tables 2 through 7). The pointer register should be the first addressed and determines which of the other four registers are acted on. The other four are the temperature, configuration, high-temperature (T_{HIGH}), and low-temperature (T_{LOW}) registers. The temperature register is 9 bits for the MAX6625 and 12 bits for the MAX6626, read only, and contains the latest temperature data. The register length is 16 bits with the unused bits masked to zero. The digital temperature data contained in the temperature register is in °C, using a two's-complement format with 1 LSB corresponding to 0.5°C for the MAX6625 and 0.0625°C for the MAX6626 (Table 8).

The configuration register is 8 bits, read/write, and contains the fault queue depth, the temperature alarm polarity select bit, the interrupt mode select bit, and the shutdown control bit. The high-temperature register is 9 bits, read/write, and contains the value that triggers

the overtemperature alarm. The low-temperature register is 9 bits, read/write, and contains the value to which the temperature must fall before the overtemperature alarm is deasserted, if in comparator mode.

Temperature Conversion

An on-chip bandgap reference produces a signal proportional to absolute temperature (PTAT), as well as the temperature-stable reference voltage necessary for the analog-to-digital conversion. The PTAT signal is digitized by the on-board ADC to a resolution of 0.5°C for the MAX6625, and 0.0625°C for the MAX6626. The resulting digital value is placed in the temperature register. The temperature conversion runs continuously and asynchronously from the I²C-compatible interface at a rate of 133ms per conversion. When the temperature register is read, the most recently completed conversion result is provided and the currently active conversion is aborted. When the bus transaction is finished by an I²C-compatible stop condition conversions resume.

Overtemperature Alarm

The dedicated overtemperature output pin, OT, has programmable polarity and two modes: comparator and interrupt. Polarity and mode are selected through the configuration register, and alarm activity is governed by a fault queue. Fault queue depth is also selected through the configuration register (Tables 5 and 6). The MAX6625P/MAX6626P OT output is open

MAX6625/MAX6626

9-Bit/12-Bit Temperature Sensors with I²C-Compatible Serial Interface in a SOT23

Table 2. Pointer Register

D7	D6	D5	D4	D3	D2	D1	D0
0	0	0	0	0	0	Register select (see Table 3)	

D7 to D2: Read all zeros, cannot be written.

Table 3. Register Select

D1	D0	REGISTER
0	0	Temperature (default)
0	1	Configuration
1	0	T _{LOW}
1	1	T _{HIGH}

Table 4. Temperature Register

PART	D15	D14	D13	D12	D11	D10	D9	D8	D7	D6	D5	D4	D3-D0
MAX6625	MSB (Sign)	Bit 7	Bit 6	Bit 5	Bit 4	Bit 3	Bit 2	Bit 1	LSB	0	0	0	0
MAX6626	MSB (Sign)	Bit 10	Bit 9	Bit 8	Bit 7	Bit 6	Bit 5	Bit 4	Bit 3	Bit 2	Bit 1	LSB	0

D6 to D0, MAX6625: Read all zeros, cannot be written.

D3 to D0, MAX6626: Read all zeros, cannot be written.

D15: MSB is the sign bit.

1 LSB = 0.5°C for the MAX6625.

1 LSB = 0.0625°C for the MAX6626.

Temperature is stored in two's-complement format.

Table 5. Configuration Register

D7	D6	D5	D4	D3	D2	D1	D0
0	0	0	Fault Queue Depth		OT Polarity	Comparator or Interrupt Mode	Shutdown

All defaults = 0.

D0: 0 = Normal operation, 1 = Shutdown.

D1: 0 = Comparator mode, 1 = Interrupt mode.

D2: 0 = Active low, 1 = Active high.

D7 to D5: Reserved locations, always write zeros.

Table 6. Fault Queue Depth

D4	D3	NO. OF FAULTS
0	0	1 (default)
0	1	2
1	0	4
1	1	6

MAX6625/MAX6626

9-Bit/12-Bit Temperature Sensors with I²C-Compatible Serial Interface in a SOT23

Table 7. THIGH and TLOW Registers

D15	D14	D13	D12	D11	D10	D9	D8	D7	D6	D5	D4	D3	D2	D1	D0
MSB	Bit 7	Bit 6	Bit 5	Bit 4	Bit 3	Bit 2	Bit 1	LSB	0	0	0	0	0	0	0

D6 to D0: Read all zeros, cannot be written.

D15: MSB is the sign bit.

Default: T_{HIGH} = +80°C (5000h), T_{LOW} = +75°C (4B00h).

LSB = 0.5°C.

Table 8. Output Code vs. Temperature

TEMPERATURE (°C)	DIGITAL OUTPUT CODE				
	MAX6625		MAX6626		
	BINARY		HEX	BINARY	
	MSB	LSB		MSB	LSB
+125.0000	0111 1101 0000 0000	7D00	0111 1101 0000 0000	7D00	
+124.9375	0111 1100 1000 0000	7C80	0111 1100 1111 0000	7CF0	
+25.0000	0001 1001 0000 0000	1900	0001 1001 0000 0000	1900	
+0.5000	0000 0000 1000 0000	0080	0000 0000 1000 0000	0080	
0.0000	0000 0000 0000 0000	0000	0000 0000 0000 0000	0000	
-0.5000	1111 1111 1000 0000	FF80	1111 1111 1000 0000	FF80	
-25.0000	1110 0111 0000 0000	E700	1110 0111 0000 0000	E700	
-55.0000	1100 1001 0000 0000	C900	1100 1001 0000 0000	C900	
*	1000 0000 0000 0000	8000	1000 0000 0000 0000	8000	

*8000h is the default value at power-up and after coming out of shutdown.

MAX6625/MAX6626

9-Bit/12-Bit Temperature Sensors with I²C-Compatible Serial Interface in a SOT23

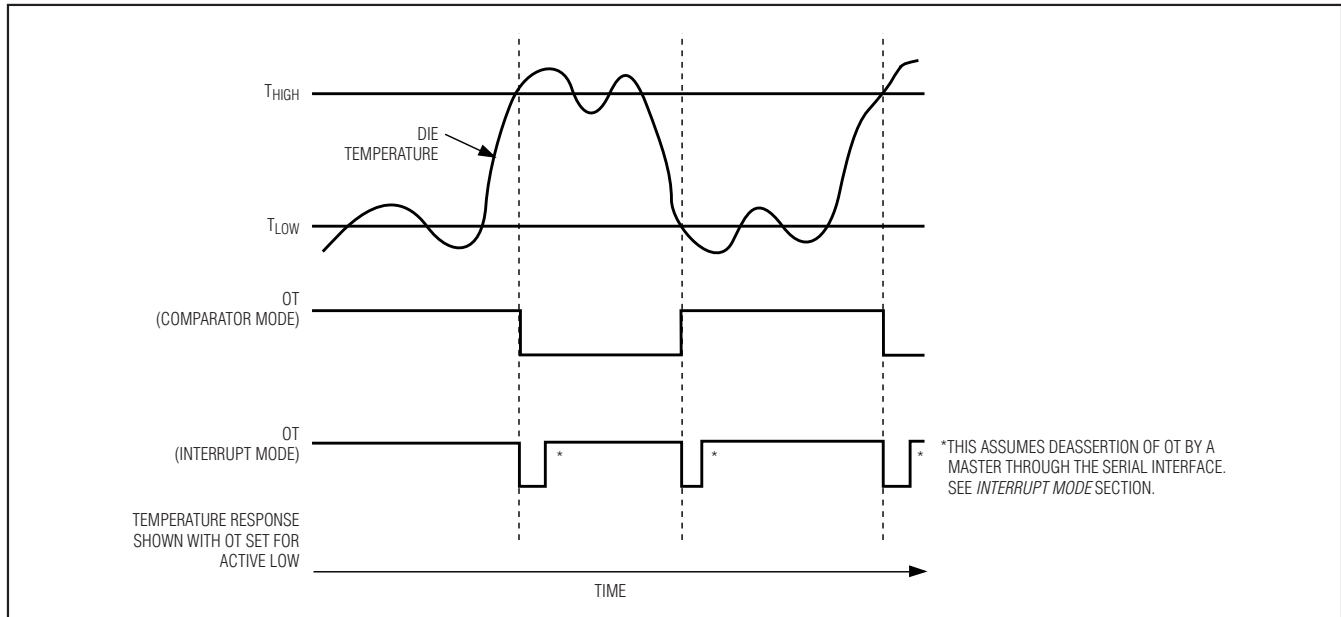

Figure 6. OT Alarm Output and Reset Diagram

drain, and the MAX6625R/MAX6626R output includes an internal 35k Ω (typ) pullup resistor. Figure 6 shows the OT alarm operation and reset details.

Fault Queue

A programmable fault queue on the MAX6625/MAX6626 eliminates spurious alarm activity in noisy environments. The queue sets the number of consecutive out-of-tolerance temperature readings that must occur before the OT alarm output is toggled. An out-of-tolerance reading is above T_{HIGH} or below T_{LOW} . The fault queue depth defaults to one at power-up and may be programmed to one, two, four, or six consecutive conversions. Any time the conversion result is in tolerance, and OT is not asserted, the queue is cleared, even if it contains some out-of-tolerance counts. Additionally, the fault queue automatically clears at power-up, in shutdown, or if a master writes to any of the T_{HIGH} , T_{LOW} , or configuration registers. Whenever the fault queue is cleared, OT is deasserted.

For example, the fault queue is set to four, two consecutive out-of-tolerance readings have occurred, and the master writes to the T_{LOW} register. The fault queue is cleared and begins to look for four new consecutive out-of-tolerance conversions.

Comparator Mode

In comparator mode, OT is asserted when the number of consecutive conversions exceeding the value in the T_{HIGH} register is equal to the depth of the fault queue.

OT deasserts when the number of consecutive conversions less than the value in the T_{LOW} register is equal to the depth of the fault queue. T_{HIGH} minus T_{LOW} is the effective hysteresis of the OT output.

For example, if T_{HIGH} is set to +100°C, T_{LOW} is set to +80°C, and the fault queue depth is set to four, OT does not assert until four consecutive conversions exceed +100°C. Then, OT does not deassert until four consecutive conversions are less than +80°C.

Comparator mode allows autonomous clearing of an OT fault without the intervention of a master and is ideal to use for driving a cooling fan (Figure 7).

Interrupt Mode

In interrupt mode, the MAX6625/MAX6626 look for a T_{HIGH} or a T_{LOW} fault based on previous fault activity. The OT pin asserts an alarm for an undertemperature fault, as well as for an overtemperature fault, depending on certain conditions. If the fault queue is cleared at power-up, the IC looks for a T_{HIGH} fault. After a T_{HIGH} fault, the IC looks for a T_{LOW} fault. After a T_{LOW} fault, the IC looks for a T_{HIGH} fault, and it bounces back and forth if properly deasserted each time. Once either fault has occurred, it remains active indefinitely until deasserted by a read of any register, and the device then begins to look for a fault of the opposite type. Also, if the fault queue is cleared, OT is deasserted and the IC once again looks for a T_{HIGH} fault. The activation of any fault is subject to the depth of the fault queue.

MAX6625/MAX6626

9-Bit/12-Bit Temperature Sensors with I²C-Compatible Serial Interface in a SOT23

Example 1: If T_{HIGH} is set to +100°C, T_{LOW} is set to +80°C, and the fault queue depth is set to four, OT does not assert until four consecutive conversions exceed +100°C. If the temperature is then read through the I²C-compatible interface, OT deasserts. OT asserts again when four consecutive conversions are less than +80°C.

Example 2: If T_{HIGH} is set to +100°C, T_{LOW} is set to +80°C, and the fault queue depth is set to four, OT does not assert until four consecutive conversions exceed +100°C. If the T_{HIGH} register is then changed to +120°C, OT deasserts and the IC looks for a new T_{HIGH} fault.

Shutdown

The MAX6625/MAX6626 offer a low-power shutdown mode. Enter shutdown mode by programming the shutdown bit of the control register high. In shutdown, the temperature register is set to 8000h and the ADC is turned off, reducing the device current draw to 1µA (typ). After coming out of shutdown, the temperature register continues to read 8000h until the first conversion result appears. The fault queue is held in reset during shutdown.

Thermal Considerations

The MAX6625/MAX6626 supply current is less than 1mA when the I²C-compatible interface is active. When used to drive high-impedance loads, the devices dissipate negligible power; therefore, the die temperature is essentially the same as the package temperature. The

key to accurate temperature monitoring is good thermal contact between the MAX6625/MAX6626 package and the monitored device or circuit. In some applications, the 6-pin SOT23 package may be small enough to fit underneath a socketed µP, allowing the device to monitor the µP's temperature directly. Heat flows in and out of plastic packages primarily through the leads. Short, wide copper traces leading to the temperature monitor ensure that heat transfers quickly and reliably. The rise in die temperature due to self-heating is given by the following formula:

$$\Delta T_J = P_D \times \theta_{JA}$$

where P_D is the power dissipated by the MAX6625/MAX6626, and θ_{JA} is the package's thermal resistance.

The typical thermal resistance is +110°C/W for the 6-pin SOT23 package. To limit the effects of self-heating, minimize the output currents. For example, if the MAX6625/MAX6626 sink 4mA with the maximum OT V_L specification of 0.8V, an additional 3.2mW of power is dissipated within the IC. This corresponds to a 0.35°C rise in the die temperature.

Applications

Figure 7 shows the MAX6625/MAX6626 used as a temperature-triggered fan controller. Figure 8 shows the MAX6625/MAX6626 used as a thermostat to control a heating element.

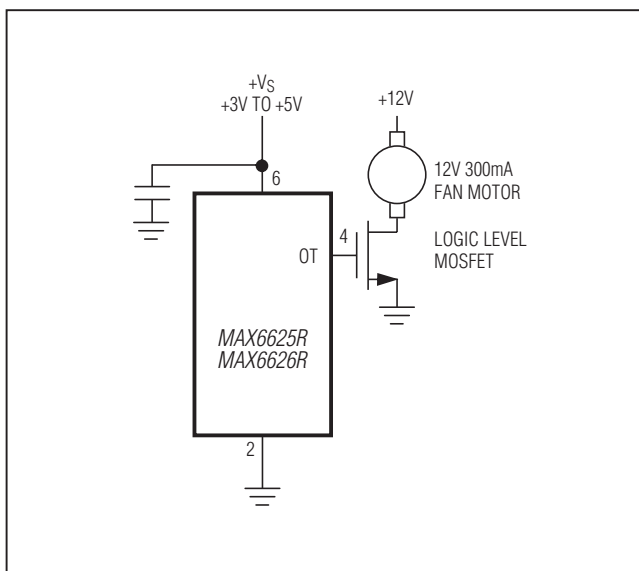

Figure 7. Fan Controller

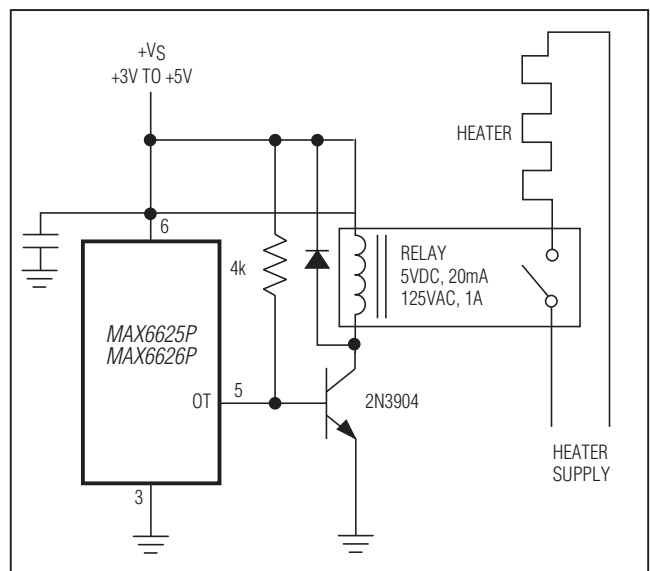

Figure 8. Simple Thermostat

MAX6625/MAX6626

9-Bit/12-Bit Temperature Sensors with I²C-Compatible Serial Interface in a SOT23

Selector Guide

PART	ALARM OUTPUT	RESOLUTION (bits)	TOP MARK
MAX6625PMTT+	Open drain	9	+ABY
MAX6625RMTT+	Internal pullup	9	+ABZ
MAX6625PMUT	Open Drain	9	AAHY
MAX6625RMUT	Internal Pullup	9	AAHZ
MAX6626PMTT+	Open drain	12	+ACA
MAX6626RMTT+	Internal pullup	12	+ACB
MAX6626PMUT	Open Drain	12	AANP
MAX6626RMUT	Internal Pullup	12	AANQ

Chip Information

PROCESS: BiCMOS

Package Information

For the latest package outline information and land patterns (footprints), go to www.maximintegrated.com/packages. Note that a "+", "#", or "-" in the package code indicates RoHS status only. Package drawings may show a different suffix character, but the drawing pertains to the package regardless of RoHS status.

PACKAGE TYPE	PACKAGE CODE	OUTLINE NO.	LAND PATTERN NO.
6 SOT23	U6F-6	21-0058	90-0175
6 TDFN-EP	T633-1	21-0137	90-0058

MAX6625/MAX6626

9-Bit/12-Bit Temperature Sensors with I²C-Compatible Serial Interface in a SOT23

Revision History

REVISION NUMBER	REVISION DATE	DESCRIPTION	PAGES CHANGED
5	11/12	Updated Table 4 and corrected hexadecimal formatting	5, 9, 10, 12
6	11/14	Updated the <i>Selector Guide</i>	13



Maxim Integrated cannot assume responsibility for use of any circuitry other than circuitry entirely embodied in a Maxim Integrated product. No circuit patent licenses are implied. Maxim Integrated reserves the right to change the circuitry and specifications without notice at any time. The parametric values (min and max limits) shown in the Electrical Characteristics table are guaranteed. Other parametric values quoted in this data sheet are provided for guidance.



Компания «ЭлектроПласт» предлагает заключение долгосрочных отношений при поставках импортных электронных компонентов на взаимовыгодных условиях!

Наши преимущества:

- Оперативные поставки широкого спектра электронных компонентов отечественного и импортного производства напрямую от производителей и с крупнейших мировых складов;
- Поставка более 17-ти миллионов наименований электронных компонентов;
- Поставка сложных, дефицитных, либо снятых с производства позиций;
- Оперативные сроки поставки под заказ (от 5 рабочих дней);
- Экспресс доставка в любую точку России;
- Техническая поддержка проекта, помощь в подборе аналогов, поставка прототипов;
- Система менеджмента качества сертифицирована по Международному стандарту ISO 9001;
- Лицензия ФСБ на осуществление работ с использованием сведений, составляющих государственную тайну;
- Поставка специализированных компонентов (Xilinx, Altera, Analog Devices, Intersil, Interpoint, Microsemi, Aeroflex, Peregrine, Syfer, Eurofarad, Texas Instrument, Miteq, Cobham, E2V, MA-COM, Hittite, Mini-Circuits, General Dynamics и др.);

Помимо этого, одним из направлений компании «ЭлектроПласт» является направление «Источники питания». Мы предлагаем Вам помощь Конструкторского отдела:

- Подбор оптимального решения, техническое обоснование при выборе компонента;
- Подбор аналогов;
- Консультации по применению компонента;
- Поставка образцов и прототипов;
- Техническая поддержка проекта;
- Защита от снятия компонента с производства.



Как с нами связаться

Телефон: 8 (812) 309 58 32 (многоканальный)

Факс: 8 (812) 320-02-42

Электронная почта: org@eplast1.ru

Адрес: 198099, г. Санкт-Петербург, ул. Калинина, дом 2, корпус 4, литера А.