

# 1-Mbit (64 K × 16) F-RAM Memory

## Features

- 1-Mbit ferroelectric random access memory (F-RAM) logically organized as 64 K × 16
  - Configurable as 128 K × 8 using  $\overline{UB}$  and  $\overline{LB}$
  - High-endurance 100 trillion ( $10^{14}$ ) read/writes
  - 151-year data retention (see the [Data Retention and Endurance](#) table)
  - NoDelay™ writes
  - Page mode operation to 30-ns cycle time
  - Advanced high-reliability ferroelectric process
- SRAM compatible
  - Industry-standard 64 K × 16 SRAM pinout
  - 60-ns access time, 90-ns cycle time
- Superior to battery-backed SRAM modules
  - No battery concerns
  - Monolithic reliability
  - True surface mount solution, no rework steps
  - Superior for moisture, shock, and vibration
- Low power consumption
  - Active current 7 mA (typ)
  - Standby current 120 μA (typ)
  - Sleep mode current 3 μA (typ)
- Low-voltage operation:  $V_{DD} = 2.0\text{ V to }3.6\text{ V}$

- Industrial temperature:  $-40\text{ °C to }+85\text{ °C}$
- 44-pin thin small outline package (TSOP) Type II
- Restriction of hazardous substances (RoHS) compliant

## Functional Overview

The FM28V102A is a 64 K × 16 nonvolatile memory that reads and writes similar to a standard SRAM. A ferroelectric random access memory or F-RAM is nonvolatile, which means that data is retained after power is removed. It provides data retention for over 151 years while eliminating the reliability concerns, functional disadvantages, and system design complexities of battery-backed SRAM (BBSRAM). Fast write timing and high write endurance make the F-RAM superior to other types of memory.

The FM28V102A operation is similar to that of other RAM devices and therefore, it can be used as a drop-in replacement for a standard SRAM in a system. Read cycles may be triggered by  $\overline{CE}$  or simply by changing the address and write cycles may be triggered by  $\overline{CE}$  or  $\overline{WE}$ . The F-RAM memory is nonvolatile due to its unique ferroelectric memory process. These features make the FM28V102A ideal for nonvolatile memory applications requiring frequent or rapid writes.

The device is available in a 400-mil 44-pin TSOP-II surface mount package. Device specifications are guaranteed over the industrial temperature range  $-40\text{ °C to }+85\text{ °C}$ .

For a complete list of related documentation, click [here](#).

## Logic Block Diagram

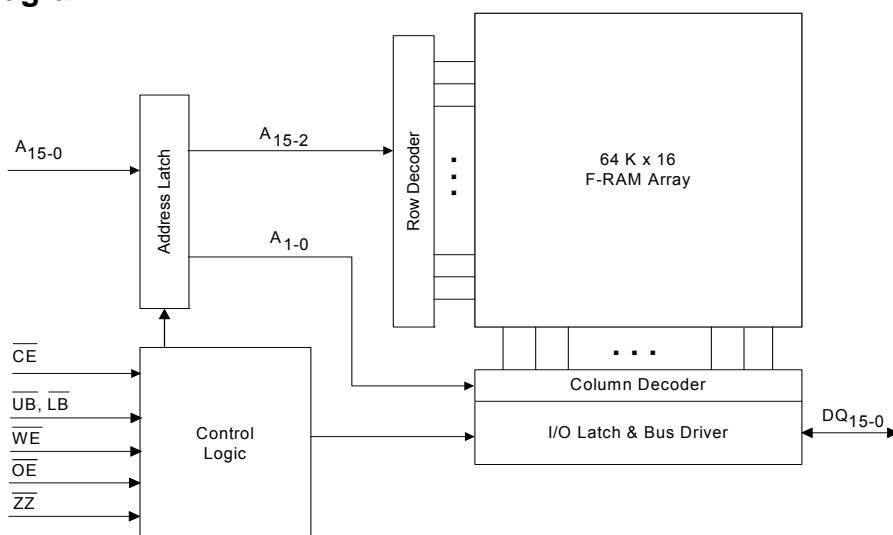

**Contents**

<b>Pinout</b> .....	<b>3</b>	<b>AC Switching Characteristics</b> .....	<b>9</b>
<b>Pin Definitions</b> .....	<b>3</b>	SRAM Read Cycle .....	9
<b>Device Operation</b> .....	<b>4</b>	SRAM Write Cycle .....	10
Memory Operation .....	4	<b>Power Cycle and Sleep Mode Timing</b> .....	<b>14</b>
Read Operation .....	4	<b>Functional Truth Table</b> .....	<b>15</b>
Write Operation .....	4	<b>Byte Select Truth Table</b> .....	<b>15</b>
Page Mode Operation .....	4	<b>Ordering Information</b> .....	<b>16</b>
Pre-charge Operation .....	4	Ordering Code Definitions .....	16
Sleep Mode .....	4	<b>Package Diagram</b> .....	<b>17</b>
SRAM Drop-In Replacement .....	5	<b>Acronyms</b> .....	<b>18</b>
Endurance .....	6	<b>Document Conventions</b> .....	<b>18</b>
<b>Maximum Ratings</b> .....	<b>7</b>	Units of Measure .....	18
<b>Operating Range</b> .....	<b>7</b>	<b>Document History Page</b> .....	<b>19</b>
<b>DC Electrical Characteristics</b> .....	<b>7</b>	<b>Sales, Solutions, and Legal Information</b> .....	<b>20</b>
<b>Data Retention and Endurance</b> .....	<b>8</b>	Worldwide Sales and Design Support .....	20
<b>Capacitance</b> .....	<b>8</b>	Products .....	20
<b>Thermal Resistance</b> .....	<b>8</b>	PSoC® Solutions .....	20
<b>AC Test Conditions</b> .....	<b>8</b>	Cypress Developer Community .....	20
		Technical Support .....	20

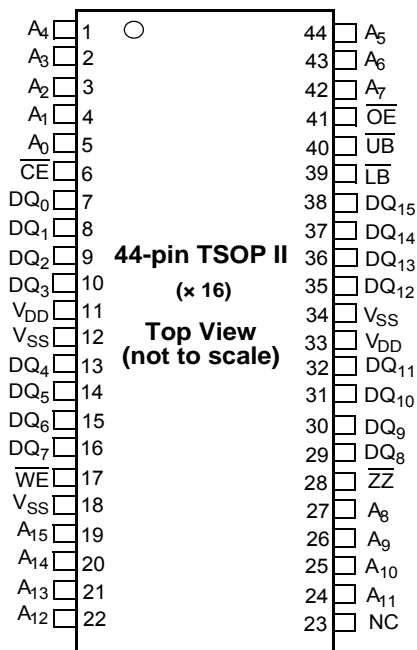
**Pinout**
**Figure 1. 44-pin TSOP II pinout**

**Pin Definitions**

Pin Name	I/O Type	Description
A <sub>15</sub> –A <sub>0</sub>	Input	<b>Address inputs:</b> The 16 address lines select one of 64K words in the F-RAM array. The lowest two address lines A <sub>1</sub> –A <sub>0</sub> may be used for page mode read and write operations.
DQ <sub>15</sub> –DQ <sub>0</sub>	Input/Output	<b>Data I/O Lines:</b> 16-bit bidirectional data bus for accessing the F-RAM array.
$\overline{WE}$	Input	<b>Write Enable:</b> A write cycle begins when $\overline{WE}$ is asserted. The rising edge causes the FM28V102A to write the data on the DQ bus to the F-RAM array. The falling edge of $\overline{WE}$ latches a new column address for page mode write cycles.
$\overline{CE}$	Input	<b>Chip Enable:</b> The device is selected and a new memory access begins on the falling edge of $\overline{CE}$ . The entire address is latched internally at this point. Subsequent changes to the A <sub>1</sub> –A <sub>0</sub> address inputs allow page mode operation.
$\overline{OE}$	Input	<b>Output Enable:</b> When $\overline{OE}$ is LOW, the FM28V102A drives the data bus when the valid read data is available. Deasserting $\overline{OE}$ HIGH tristates the DQ pins.
$\overline{UB}$	Input	<b>Upper Byte Select:</b> Enables DQ <sub>15</sub> –DQ <sub>8</sub> pins during reads and writes. These pins are HI-Z if $\overline{UB}$ is HIGH. If the user does not perform byte writes and the device is not configured as a 128 K × 8, the $\overline{UB}$ and $\overline{LB}$ pins may be tied to ground.
$\overline{LB}$	Input	<b>Lower Byte Select:</b> Enables DQ <sub>7</sub> –DQ <sub>0</sub> pins during reads and writes. These pins are HI-Z if $\overline{LB}$ is HIGH. If the user does not perform byte writes and the device is not configured as a 128 K × 8, the $\overline{UB}$ and $\overline{LB}$ pins may be tied to ground.
$\overline{ZZ}$	Input	<b>Sleep:</b> When $\overline{ZZ}$ is LOW, the device enters a low-power sleep mode for the lowest supply current condition. $\overline{ZZ}$ must be HIGH for a normal read/write operation. This pin must be tied to V <sub>DD</sub> if not used.
V <sub>SS</sub>	Ground	Ground for the device. Must be connected to the ground of the system.
V <sub>DD</sub>	Power supply	Power supply input to the device.
NC	No connect	No connect. This pin is not connected to the die.

## Device Operation

The FM28V102A is a word wide F-RAM memory logically organized as  $65,536 \times 16$  and accessed using an industry-standard parallel interface. All data written to the part is immediately nonvolatile with no delay. The device offers page mode operation, which provides high-speed access to addresses within a page (row). Access to a different page requires that either  $\overline{CE}$  transitions LOW or the upper address ( $A_{15}$ – $A_2$ ) changes. See the [Functional Truth Table on page 15](#) for a complete description of read and write modes.

## Memory Operation

Users access 65,536 memory locations, each with 16 data bits through a parallel interface. The F-RAM array is organized as 16,384 rows each having 64 bits. Each row has four column locations, which allow fast access in page mode operation. When an initial address is latched by the falling edge of  $\overline{CE}$ , subsequent column locations may be accessed without the need to toggle  $\overline{CE}$ . When  $\overline{CE}$  is deasserted HIGH, a pre-charge operation begins. Writes occur immediately at the end of the access with no delay. The  $\overline{WE}$  pin must be toggled for each write operation. The write data is stored in the nonvolatile memory array immediately, which is a feature unique to F-RAM called NoDelay writes.

## Read Operation

A read operation begins on the falling edge of  $\overline{CE}$ . The falling edge of  $\overline{CE}$  causes the address to be latched and starts a memory read cycle if  $\overline{WE}$  is HIGH. Data becomes available on the bus after the access time is met. When the address is latched and the access completed, a new access to a random location (different row) may begin while  $\overline{CE}$  is still LOW. The minimum cycle time for random addresses is  $t_{RC}$ . Note that unlike SRAMs, the FM28V102A's  $\overline{CE}$ -initiated access time is faster than the address access time.

The FM28V102A will drive the data bus when  $\overline{OE}$  and at least one of the byte enables ( $\overline{UB}$ ,  $\overline{LB}$ ) is asserted LOW. The upper data byte is driven when  $\overline{UB}$  is LOW, and the lower data byte is driven when  $\overline{LB}$  is LOW. If  $\overline{OE}$  is asserted after the memory access time is met, the data bus will be driven with valid data. If  $\overline{OE}$  is asserted before completing the memory access, the data bus will not be driven until valid data is available. This feature minimizes supply current in the system by eliminating transients caused by invalid data being driven to the bus. When  $\overline{OE}$  is deasserted HIGH, the data bus will remain in a HI-Z state.

## Write Operation

In the FM28V102A, writes occur in the same interval as reads. The FM28V102A supports both  $\overline{CE}$  and  $\overline{WE}$  controlled write cycles. In both cases, the address  $A_{15}$ – $A_2$  is latched on the falling edge of  $\overline{CE}$ .

In a  $\overline{CE}$ -controlled write, the  $\overline{WE}$  signal is asserted before beginning the memory cycle. That is,  $\overline{WE}$  is LOW when  $\overline{CE}$  falls. In this case, the device begins the memory cycle as a write. The FM28V102A will not drive the data bus regardless of the state of  $\overline{OE}$  as long as  $\overline{WE}$  is LOW. Input data must be valid when  $\overline{CE}$  is

deasserted HIGH. In a  $\overline{WE}$ -controlled write, the memory cycle begins on the falling edge of  $\overline{CE}$ . The  $\overline{WE}$  signal falls some time later. Therefore, the memory cycle begins as a read. The data bus will be driven if  $\overline{OE}$  is LOW; however, it will be HI-Z when  $\overline{WE}$  is asserted LOW. The  $\overline{CE}$ - and  $\overline{WE}$ -controlled write timing cases are shown in the Switching Waveforms on page 13.

Write access to the array begins on the falling edge of  $\overline{WE}$  after the memory cycle is initiated. The write access terminates on the rising edge of  $\overline{WE}$  or  $\overline{CE}$ , whichever comes first. A valid write operation requires the user to meet the access time specification before deasserting  $\overline{WE}$  or  $\overline{CE}$ . The data setup time indicates the interval during which data cannot change before the end of the write access (rising edge of  $\overline{WE}$  or  $\overline{CE}$ ).

Unlike other nonvolatile memory technologies, there is no write delay with F-RAM. Because the read and write access times of the underlying memory are the same, the user experiences no delay through the bus. The entire memory operation occurs in a single bus cycle. Data polling, a technique used with EEPROMs to determine if a write is complete, is unnecessary.

## Page Mode Operation

The F-RAM array is organized as 16,384 rows each having 64 bits. Each row has four column-address locations. Address inputs  $A_1$ – $A_0$  define the column address to be accessed. An access can start on any column address, and other column locations may be accessed without the need to toggle the  $\overline{CE}$  pin. For fast access reads, after the first data byte is driven to the bus, the column address inputs  $A_1$ – $A_0$  may be changed to a new value. A new data byte is then driven to the DQ pins no later than  $t_{AAP}$ , which is less than half the initial read access time. For fast access writes, the first write pulse defines the first write access. While  $\overline{CE}$  is LOW, a subsequent write pulse along with a new column address provides a page mode write access.

## Pre-charge Operation

The pre-charge operation is an internal condition in which the memory state is prepared for a new access. Pre-charge is user-initiated by driving the  $\overline{CE}$  signal HIGH. It must remain HIGH for at least the minimum pre-charge time,  $t_{PC}$ .

Pre-charge is also activated by changing the upper addresses,  $A_{15}$ – $A_2$ . The current row is first closed before accessing the new row. The device automatically detects an upper order address change, which starts a pre-charge operation. The new address is latched and the new read data is valid within the  $t_{AA}$  address access time; see [Figure 6 on page 11](#). A similar sequence occurs for write cycles; see [Figure 11 on page 12](#). The rate at which random addresses can be issued is  $t_{RC}$  and  $t_{WC}$ , respectively.

## Sleep Mode

The device incorporates a sleep mode of operation, which allows the user to achieve the lowest power supply current condition. It enters a low-power sleep mode by asserting the  $\overline{ZZ}$  pin LOW. Read and write operations must complete before the  $\overline{ZZ}$  pin going LOW. When  $\overline{ZZ}$  is LOW, all pins are ignored except the  $\overline{ZZ}$  pin. When  $\overline{ZZ}$  is deasserted HIGH, there is some time delay ( $t_{ZZEX}$ ) before the user can access the device. If sleep mode is not used, the  $\overline{ZZ}$  pin must be tied to  $V_{DD}$ .

Figure 2. Sleep/Standby State Diagram

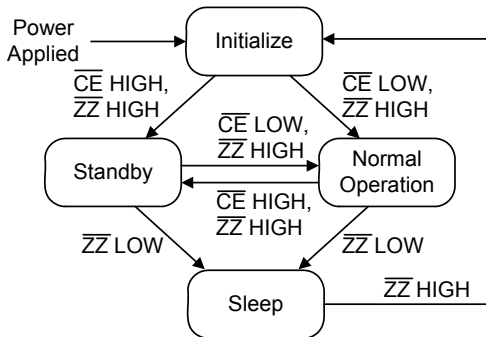

**SRAM Drop-In Replacement**

The FM28V102A is designed to be a drop-in replacement for standard asynchronous SRAMs. The device does not require  $\overline{CE}$  to toggle for each new address.  $\overline{CE}$  may remain LOW indefinitely. While  $\overline{CE}$  is LOW, the device automatically detects address changes and a new access begins. This functionality allows  $\overline{CE}$  to be grounded, similar to an SRAM. It also allows page mode operation at speeds up to 33 MHz.

Figure 3 shows a pull-up resistor on  $\overline{CE}$ , which will keep the pin HIGH during power cycles, assuming the MCU / MPU pin tristates during the reset condition. The pull-up resistor value should be chosen to ensure the  $\overline{CE}$  pin tracks  $V_{DD}$  to a high enough value, so that the current drawn when  $\overline{CE}$  is LOW is not an issue. A 10-k $\Omega$  resistor draws 330  $\mu$ A when  $\overline{CE}$  is LOW and  $V_{DD} = 3.3$  V

Figure 3. Use of Pull-up Resistor on  $\overline{CE}$

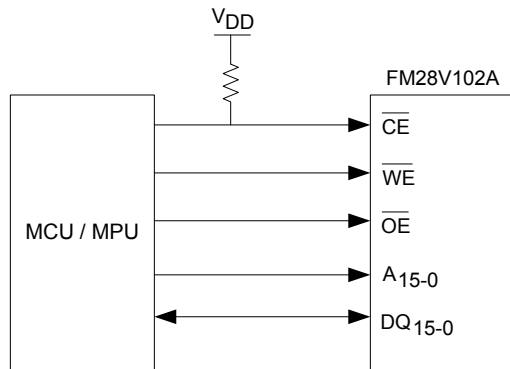

Note that if  $\overline{CE}$  is tied to ground, the user must be sure  $\overline{WE}$  is not LOW at power-up or power-down events. If  $\overline{CE}$  and  $\overline{WE}$  are both LOW during power cycles, data will be corrupted. Figure 4 shows a pull-up resistor on  $\overline{WE}$ , which will keep the pin HIGH during power cycles, assuming the MCU/MPU pin tristates during the reset condition. The pull-up resistor value should be chosen to ensure the  $\overline{WE}$  pin tracks  $V_{DD}$  to a high enough value, so that the current drawn when  $\overline{WE}$  is LOW is not an issue. A 10-k $\Omega$  resistor draws 330  $\mu$ A when  $\overline{WE}$  is LOW and  $V_{DD} = 3.3$  V.

Figure 4. Use of Pull-up Resistor on  $\overline{WE}$

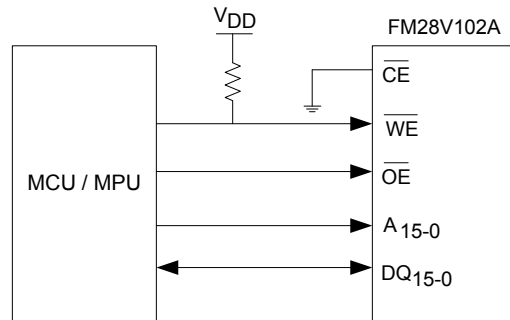

For applications that require the lowest power consumption, the  $\overline{CE}$  signal should be active (LOW) only during memory accesses. The FM28V102A draws supply current while  $\overline{CE}$  is LOW, even if addresses and control signals are static. While  $\overline{CE}$  is HIGH, the device draws no more than the maximum standby current,  $I_{SB}$ . The  $\overline{UB}$  and  $\overline{LB}$  byte select pins are active for both read and write cycles. They may be used to allow the device to be wired as a 128 K  $\times$  8 memory. The upper and lower data bytes can be tied together and controlled with the byte selects. Individual byte enables or the next higher address line  $A_{16}$  may be available from the system processor.

Figure 5. FM28V102A Wired as 128 K x 8

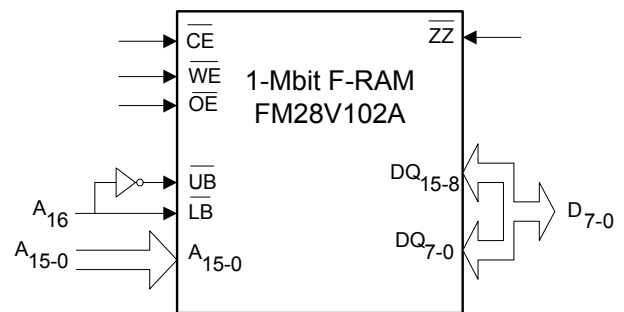

**Endurance**

The FM28V102A is capable of being accessed at least  $10^{14}$  times – reads or writes. An F-RAM memory operates with a read and restore mechanism. Therefore, an endurance cycle is applied on a row basis. The F-RAM architecture is based on an array of rows and columns. Rows are defined by  $A_{15-2}$  and column addresses by  $A_{1-0}$ . The array is organized as 16K rows of four words each. The entire row is internally accessed once whether a single 16-bit word or all four words are read or written. Each word in the row is counted only once in an endurance calculation.

The user may choose to write CPU instructions and run them from a certain address space. Table 1 shows endurance calculations for a 256-byte repeating loop, which includes a starting address, three-page mode accesses, and a  $\overline{CE}$  pre-charge. The number of bus clock cycles needed to complete a four-word transaction is 4 + 1 at lower bus speeds, but 5 + 2 at 33 MHz due to initial read latency and an extra clock cycle to

satisfy the device's pre-charge timing constraint  $t_{PC}$ . The entire loop causes each byte to experience only one endurance cycle. The F-RAM read and write endurance is virtually unlimited even at a 33-MHz system bus clock rate.

**Table 1. Time to Reach 100 Trillion Cycles for Repeating 256-byte Loop**

Bus Freq (MHz)	Bus Cycle Time (ns)	256-byte Transaction Time ( $\mu$ s)	Endurance Cycles/sec	Endurance Cycles/year	Years to Reach $10^{14}$ Cycles
33	30	10.56	94,690	$2.98 \times 10^{12}$	33.5
25	40	12.8	78,125	$2.46 \times 10^{12}$	40.6
10	100	28.8	34,720	$1.09 \times 10^{12}$	91.7
5	200	57.6	17,360	$5.47 \times 10^{11}$	182.8

## Maximum Ratings

Exceeding maximum ratings may shorten the useful life of the device. These user guidelines are not tested.

Storage temperature ..... -55 °C to +125 °C  
 Maximum accumulated storage time  
 At 125 °C ambient temperature ..... 1000 h  
 At 85 °C ambient temperature ..... 10 Years  
 Ambient temperature  
 with power applied ..... -55 °C to +125 °C  
 Supply voltage on  $V_{DD}$  relative to  $V_{SS}$  ..... -1.0 V to + 4.5 V  
 Voltage applied to outputs  
 in High Z state ..... -0.5 V to  $V_{DD} + 0.5$  V  
 Input voltage ..... -1.0 V to + 4.5 V and  $V_{IN} < V_{DD} + 1.0$  V

Transient voltage (< 20 ns) on  
 any pin to ground potential ..... -2.0 V to  $V_{CC} + 2.0$  V  
 Package power dissipation  
 capability ( $T_A = 25$  °C) ..... 1.0 W  
 Surface mount Pb soldering  
 temperature (3 seconds) ..... +260 °C  
 DC output current (1 output at a time, 1s duration) .... 15 mA  
 Static discharge voltage  
 Human Body Model (AEC-Q100-002 Rev. E) ..... 2 kV  
 Charged Device Model (AEC-Q100-011 Rev. B) ..... 500 V  
 Latch-up current ..... > 140 mA

## Operating Range

Range	Ambient Temperature ( $T_A$ )	$V_{DD}$
Industrial	-40 °C to +85 °C	2.0 V to 3.6 V

## DC Electrical Characteristics

Over the [Operating Range](#)

Parameter	Description	Test Conditions	Min	Typ <sup>[1]</sup>	Max	Unit	
$V_{DD}$	Power supply voltage		2.0	3.3	3.6	V	
$I_{DD}$	$V_{DD}$ supply current	$V_{DD} = 3.6$ V, $\overline{CE}$ cycling at min. cycle time. All inputs toggling at CMOS levels (0.2 V or $V_{DD} - 0.2$ V), all DQ pins unloaded.	-	7	12	mA	
$I_{SB}$	Standby current	$V_{DD} = 3.6$ V, $\overline{CE}$ at $V_{DD}$ . All other pins are static and at CMOS levels (0.2 V or $V_{DD} - 0.2$ V), $\overline{ZZ}$ is HIGH	$T_A = 25$ °C	-	120	150	$\mu$ A
			$T_A = 85$ °C	-	-	250	$\mu$ A
$I_{ZZ}$	Sleep mode current	$V_{DD} = 3.6$ V, $\overline{ZZ}$ is LOW, All other inputs $V_{SS}$ or $V_{DD}$ .	$T_A = 25$ °C	-	3	5	$\mu$ A
			$T_A = 85$ °C	-	-	8	$\mu$ A
$I_{LI}$	Input leakage current	$V_{IN}$ between $V_{DD}$ and $V_{SS}$	-	-	$\pm 1$	$\mu$ A	
$I_{LO}$	Output leakage current	$V_{OUT}$ between $V_{DD}$ and $V_{SS}$	-	-	$\pm 1$	$\mu$ A	
$V_{IH1}$	Input HIGH voltage	$V_{DD} = 2.7$ V to 3.6 V	2.2	-	$V_{DD} + 0.3$	V	
$V_{IH2}$	Input HIGH voltage	$V_{DD} = 2.0$ V to 2.7 V	$0.7 \times V_{DD}$	-	-	V	
$V_{IL1}$	Input LOW voltage	$V_{DD} = 2.7$ V to 3.6 V	-0.3	-	0.8	V	
$V_{IL2}$	Input LOW voltage	$V_{DD} = 2.0$ V to 2.7 V	-0.3	-	$0.3 \times V_{DD}$	V	
$V_{OH1}$	Output HIGH voltage	$I_{OH} = -1$ mA, $V_{DD} > 2.7$ V	2.4	-	-	V	
$V_{OH2}$	Output HIGH voltage	$I_{OH} = -100$ $\mu$ A	$V_{DD} - 0.2$	-	-	V	
$V_{OL1}$	Output LOW voltage	$I_{OL} = 2$ mA, $V_{DD} > 2.7$ V	-	-	0.4	V	
$V_{OL2}$	Output LOW voltage	$I_{OL} = 150$ $\mu$ A	-	-	0.2	V	

### Note

1. Typical values are at 25 °C,  $V_{DD} = V_{DD}$  (typ). Not 100% tested.

### Data Retention and Endurance

Parameter	Description	Test condition	Min	Max	Unit
T <sub>DR</sub>	Data retention	T <sub>A</sub> = 85 °C	10	–	Years
		T <sub>A</sub> = 75 °C	38	–	
		T <sub>A</sub> = 65 °C	151	–	
NV <sub>C</sub>	Endurance	Over operating temperature	10 <sup>14</sup>	–	Cycles

### Capacitance

Parameter	Description	Test Conditions	Max	Unit
C <sub>I/O</sub>	Input/Output capacitance (DQ)	T <sub>A</sub> = 25 °C, f = 1 MHz, V <sub>DD</sub> = V <sub>DD(Typ)</sub>	8	pF
C <sub>IN</sub>	Input capacitance		6	pF
C <sub>ZZ</sub>	Input capacitance of $\overline{ZZ}$ pin		8	pF

### Thermal Resistance

Parameter	Description	Test Conditions	44-pin TSOP II	Unit
Θ <sub>JA</sub>	Thermal resistance (junction to ambient)	Test conditions follow standard test methods and procedures for measuring thermal impedance, in accordance with EIA/JESD51.	107	°C/W
Θ <sub>JC</sub>	Thermal resistance (junction to case)		25	°C/W

### AC Test Conditions

Input pulse levels ..... 0 V to 3 V  
 Input rise and fall times (10%–90%) ..... ≤ 3 ns  
 Input and output timing reference levels ..... 1.5 V  
 Output load capacitance ..... 30 pF



## AC Switching Characteristics

 Over the [Operating Range](#)

Parameters <sup>[2]</sup>		Description	V <sub>DD</sub> = 2.0 V to 2.7 V		V <sub>DD</sub> = 2.7 V to 3.6 V		Unit
Cypress Parameter	Alt Parameter		Min	Max	Min	Max	
<b>SRAM Read Cycle</b>							
t <sub>CE</sub>	t <sub>ACE</sub>	Chip enable access time	–	70	–	60	ns
t <sub>RC</sub>	–	Read cycle time	105	–	90	–	ns
t <sub>AA</sub>	–	Address access time, A <sub>15-2</sub>	–	105	–	90	ns
t <sub>OH</sub>	t <sub>OHA</sub>	Output hold time, A <sub>15-2</sub>	20	–	20	–	ns
t <sub>AAP</sub>	–	Page mode access time, A <sub>1-0</sub>	–	40	–	30	ns
t <sub>OHP</sub>	–	Page mode output hold time, A <sub>1-0</sub>	3	–	3	–	ns
t <sub>CA</sub>	–	Chip enable active time	70	–	60	–	ns
t <sub>PC</sub>	–	Pre-charge time	35	–	30	–	ns
t <sub>BA</sub>	t <sub>BW</sub>	$\overline{UB}$ , $\overline{LB}$ access time	–	25	–	15	ns
t <sub>AS</sub>	t <sub>SA</sub>	Address setup time (to $\overline{CE}$ LOW)	0	–	0	–	ns
t <sub>AH</sub>	t <sub>HA</sub>	Address hold time ( $\overline{CE}$ Controlled)	70	–	60	–	ns
t <sub>OE</sub>	t <sub>DOE</sub>	Output enable access time	–	25	–	15	ns
t <sub>HZ</sub> <sup>[3, 4]</sup>	t <sub>HZCE</sub>	Chip Enable to output HI-Z	–	15	–	10	ns
t <sub>OHZ</sub> <sup>[3, 4]</sup>	t <sub>HZOE</sub>	Output enable HIGH to output HI-Z	–	15	–	10	ns
t <sub>BHZ</sub> <sup>[3, 4]</sup>	t <sub>HZBE</sub>	$\overline{UB}$ , $\overline{LB}$ HIGHHIGH to output HI-Z	–	15	–	10	ns

### Notes

- Test conditions assume a signal transition time of 3 ns or less, timing reference levels of  $0.5 \times V_{DD}$ , input pulse levels of 0 to 3 V, output loading of the specified  $I_{OL}/I_{OH}$  and load capacitance shown in [AC Test Conditions on page 8](#).
- t<sub>HZ</sub>, t<sub>OHZ</sub> and t<sub>BHZ</sub> are specified with a load capacitance of 5 pF. Transition is measured when the outputs enter a high impedance state.
- This parameter is characterized but not 100% tested.

**AC Switching Characteristics** (continued)

 Over the [Operating Range](#)

Parameters <sup>[2]</sup>		Description	V <sub>DD</sub> = 2.0 V to 2.7 V		V <sub>DD</sub> = 2.7 V to 3.6 V		Unit
Cypress Parameter	Alt Parameter		Min	Max	Min	Max	
<b>SRAM Write Cycle</b>							
t <sub>WC</sub>	t <sub>WC</sub>	Write cycle time	105	–	90	–	ns
t <sub>CA</sub>	–	Chip enable active time	70	–	60	–	ns
t <sub>CW</sub>	t <sub>SCE</sub>	Chip enable to write enable HIGH	70	–	60	–	ns
t <sub>PC</sub>	–	Pre-charge time	35	–	30	–	ns
t <sub>PWC</sub>	–	Page mode write enable cycle time	40	–	30	–	ns
t <sub>WP</sub>	t <sub>PWE</sub>	Write enable pulse width	22	–	18	–	ns
t <sub>WP2</sub>	t <sub>BW</sub>	$\overline{UB}$ , $\overline{LB}$ pulse width	22	–	18	–	ns
t <sub>WP3</sub>	t <sub>PWE</sub>	$\overline{WE}$ LOW to $\overline{UB}$ , $\overline{LB}$ HIGH	22	–	18	–	ns
t <sub>AS</sub>	t <sub>SA</sub>	Address setup time (to $\overline{CE}$ LOW)	0	–	0	–	ns
t <sub>AH</sub>	t <sub>HA</sub>	Address hold time ( $\overline{CE}$ Controlled)	70	–	60	–	ns
t <sub>ASP</sub>	–	Page mode address setup time (to $\overline{WE}$ LOW)	8	–	5	–	ns
t <sub>AHP</sub>	–	Page mode address hold time (to $\overline{WE}$ LOW)	20	–	15	–	ns
t <sub>WLC</sub>	t <sub>PWE</sub>	Write enable LOW to chip disabled	30	–	25	–	ns
t <sub>BLC</sub>	t <sub>BW</sub>	$\overline{UB}$ , $\overline{LB}$ LOW to chip disabled	30	–	25	–	ns
t <sub>WLA</sub>	–	Write enable LOW to address change, A <sub>15-2</sub>	30	–	25	–	ns
t <sub>AWH</sub>	–	Address change to write enable HIGH, A <sub>15-2</sub>	105	–	90	–	ns
t <sub>DS</sub>	t <sub>SD</sub>	Data input setup time	20	–	15	–	ns
t <sub>DH</sub>	t <sub>HD</sub>	Data input hold time	0	–	0	–	ns
t <sub>WZ</sub> <sup>[5, 6]</sup>	t <sub>HZWE</sub>	Write enable LOW to output HI-Z	–	10	–	10	ns
t <sub>WX</sub> <sup>[6]</sup>	–	Write enable HIGH to output driven	8	–	5	–	ns
t <sub>BDS</sub>	–	Byte disable setup time (to $\overline{WE}$ LOW)	8	–	5	–	ns
t <sub>BDH</sub>	–	Byte disable hold time (to $\overline{WE}$ HIGH)	8	–	5	–	ns

**Notes**

5. t<sub>WZ</sub> is specified with a load capacitance of 5 pF. Transition is measured when the outputs enter a high impedance state.
6. This parameter is characterized but not 100% tested.

Figure 6. Read Cycle Timing 1 ( $\overline{CE}$  LOW,  $\overline{OE}$  LOW)

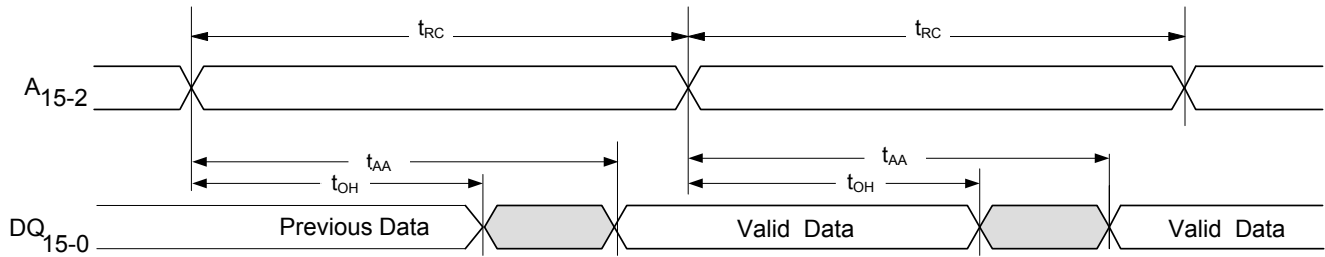

Figure 7. Read Cycle Timing 2 ( $\overline{CE}$  Controlled)

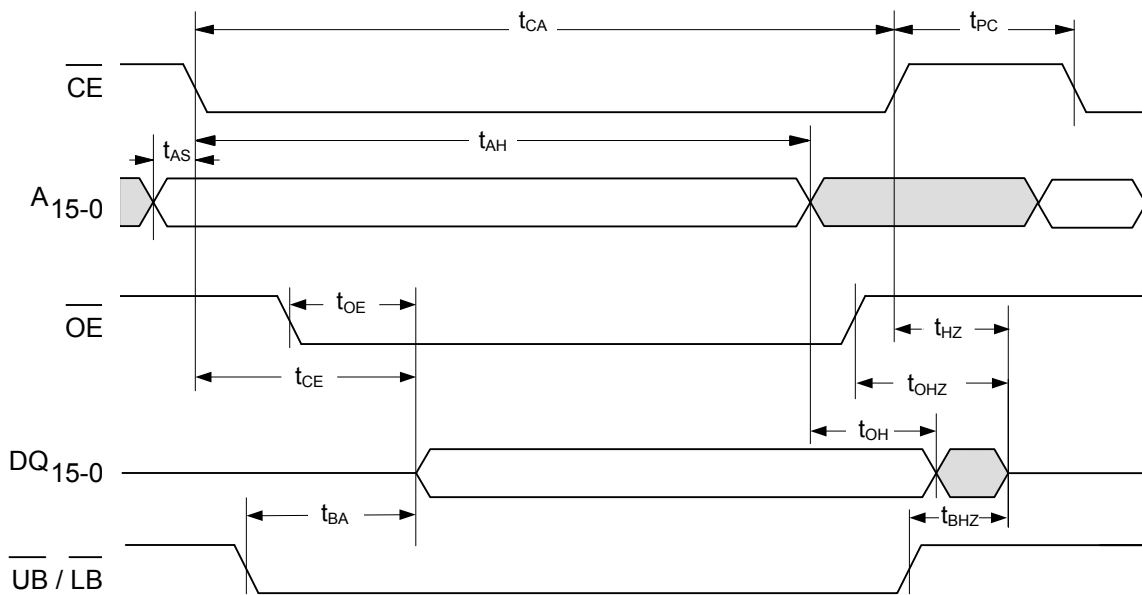
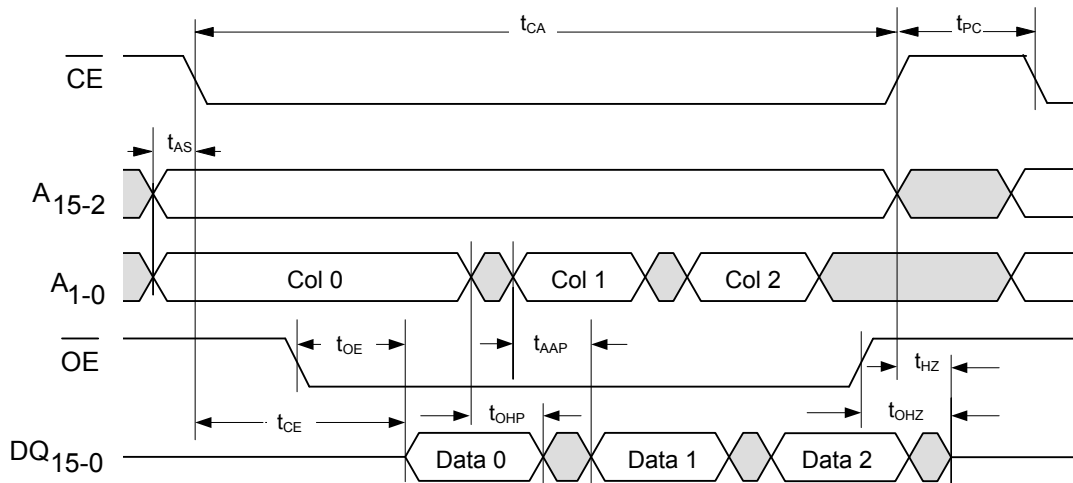

Figure 8. Page Mode Read Cycle Timing <sup>[7]</sup>



Note

7. Although sequential column addressing is shown, it is not required.

Figure 9. Write Cycle Timing 1 ( $\overline{WE}$  Controlled) [8]

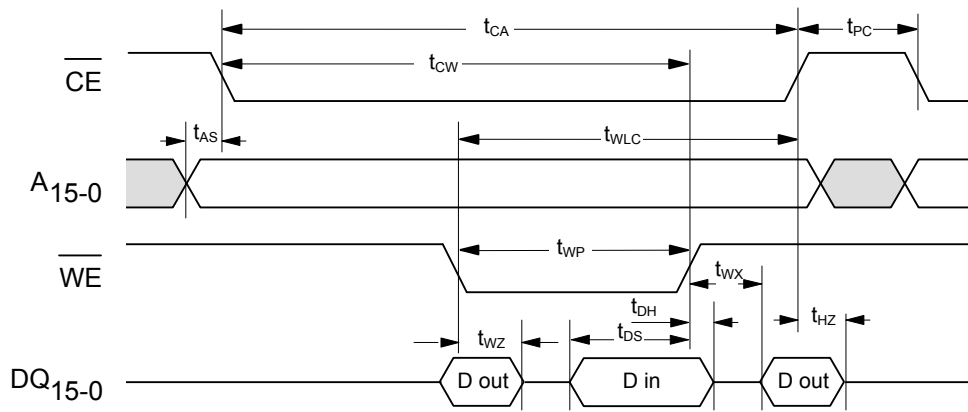

Figure 10. Write Cycle Timing 2 ( $\overline{CE}$  Controlled)

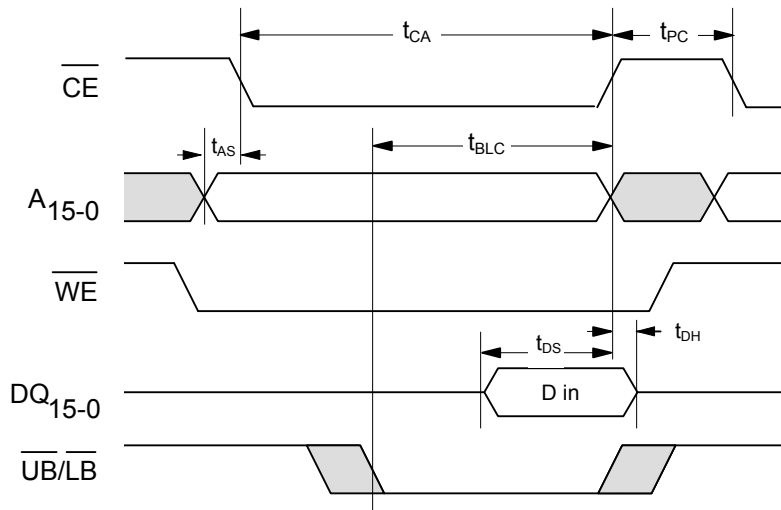
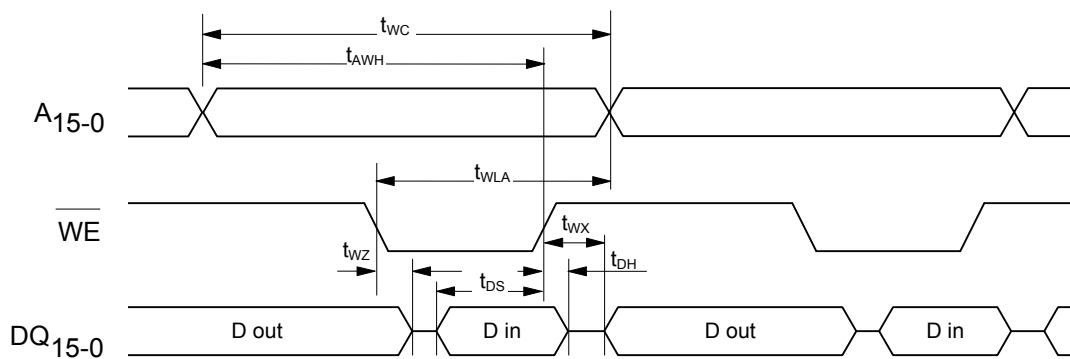

Figure 11. Write Cycle Timing 3 ( $\overline{CE}$  LOW) [8]



**Note**

8.  $\overline{OE}$  (not shown) is LOW only to show the effect of  $\overline{WE}$  on DQ pins.

Figure 12. Write Cycle Timing 4 ( $\overline{\text{CE}}$  LOW) <sup>[9]</sup>

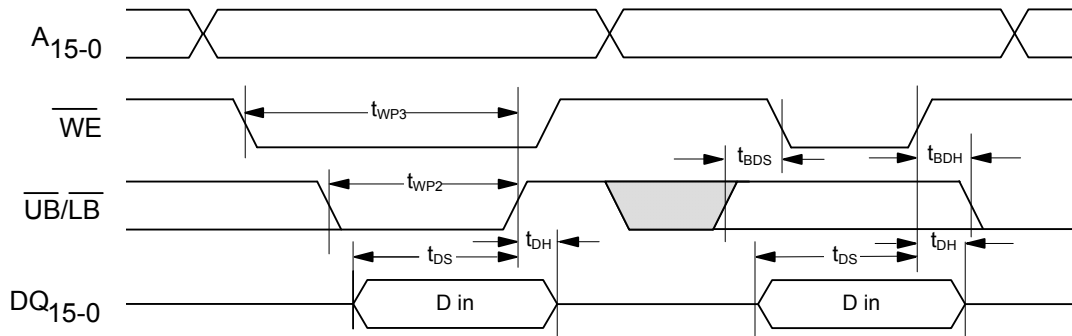
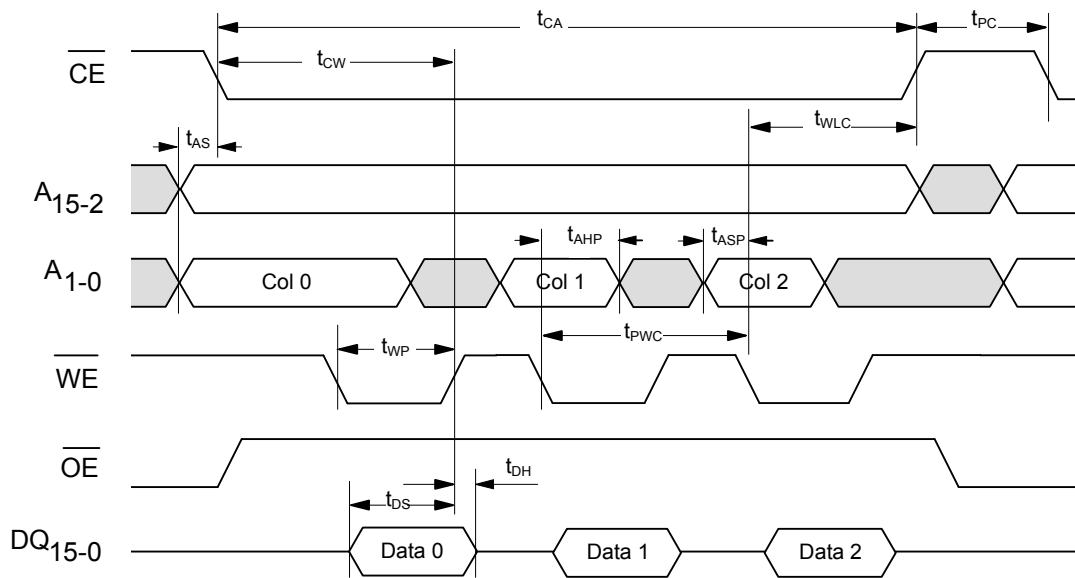

Figure 13. Page Mode Write Cycle Timing



**Note**

9.  $\overline{\text{UB}}$  and  $\overline{\text{LB}}$  to show byte enable and byte masking cases.

## Power Cycle and Sleep Mode Timing

Over the [Operating Range](#)

Parameter	Description	Min	Max	Unit
$t_{PU}$	Power-up (after $V_{DD}$ min. is reached) to first access time	1	–	ms
$t_{PD}$	Last write ( $\overline{WE}$ HIGH) to power down time	0	–	$\mu$ s
$t_{VR}^{[10]}$	$V_{DD}$ power-up ramp rate	50	–	$\mu$ s/V
$t_{VF}^{[10]}$	$V_{DD}$ power-down ramp rate	100	–	$\mu$ s/V
$t_{ZZH}$	$\overline{ZZ}$ active to DQ HI-Z time	–	20	ns
$t_{WEZZ}$	Last write to sleep mode entry time	0	–	$\mu$ s
$t_{ZZL}$	$\overline{ZZ}$ active LOW time	1	–	$\mu$ s
$t_{ZZEN}$	Sleep mode entry time ( $\overline{ZZ}$ LOW to $\overline{CE}$ don't care)	–	0	$\mu$ s
$t_{ZZEX}$	Sleep mode exit time ( $\overline{ZZ}$ HIGH to 1 <sup>st</sup> access after wakeup)	–	450	$\mu$ s

**Figure 14. Power Cycle and Sleep Mode Timing**

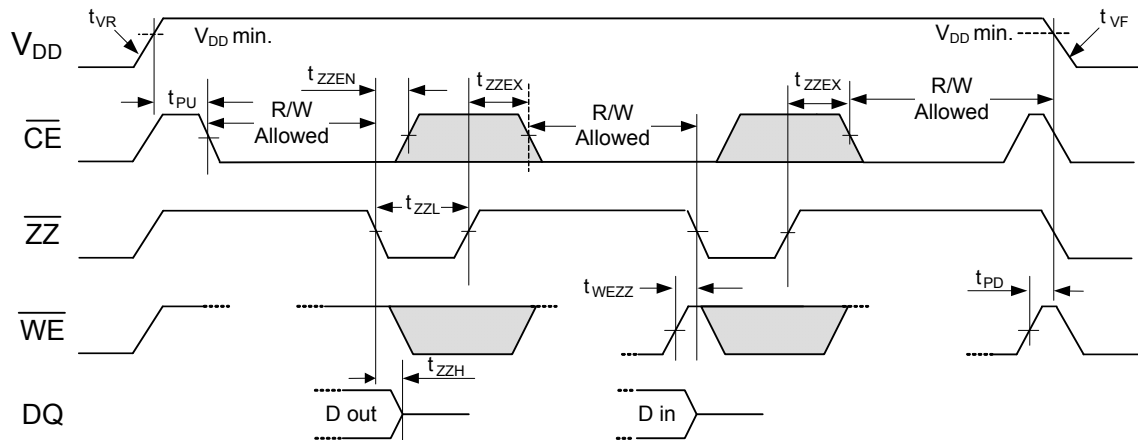

**Note**

10. Slope measured at any point on the  $V_{DD}$  waveform.

**Functional Truth Table**

$\overline{CE}$	$\overline{WE}$	A <sub>15-2</sub>	A <sub>1-0</sub>	$\overline{ZZ}$	Operation <sup>[11, 12]</sup>
X	X	X	X	L	Sleep Mode
H	X	X	X	H	Standby/Idle
↓ L	H H	V V	V V	H H	Read
L	H	No Change	Change	H	Page Mode Read
L	H	Change	V	H	Random Read
↓ L	L L	V V	V V	H H	$\overline{CE}$ -Controlled Write <sup>[12]</sup>
L	↓	V	V	H	$\overline{WE}$ -Controlled Write <sup>[12, 13]</sup>
L	↓	No Change	V	H	Page Mode Write <sup>[14]</sup>
↑ L	X X	X X	X X	H H	Starts pre-charge

**Byte Select Truth Table**

$\overline{WE}$	$\overline{OE}$	$\overline{LB}$	$\overline{UB}$	Operation <sup>[15]</sup>
H	H	X	X	Read; Outputs disabled
	X	H	H	
H	L	H	L	Read upper byte; HI-Z lower byte
		L	H	Read lower byte; HI-Z upper byte
		L	L	Read both bytes
L	X	H	L	Write upper byte; Mask lower byte
		L	H	Write lower byte; Mask upper byte
		L	L	Write both bytes

**Notes**

11. H = Logic HIGH, L = Logic LOW, V = Valid Data, X = Don't Care, ↓ = toggle LOW, ↑ = toggle HIGH.
12. For write cycles, data-in is latched on the rising edge of  $\overline{CE}$  or  $\overline{WE}$ , whichever comes first.
13.  $\overline{WE}$ -controlled write cycle begins as a Read cycle and then A<sub>15-2</sub> is latched.
14. Addresses A<sub>1-0</sub> must remain stable for at least 15 ns during page mode operation.
15. The  $\overline{UB}$  and  $\overline{LB}$  pins may be grounded if 1) the system does not perform byte writes and 2) the device is not configured as a 128 K x 8.

**Ordering Information**

Access time (ns)	Ordering Code	Package Diagram	Package Type	Operating Range
60	FM28V102A-TG	51-85087	44-pin TSOP II	Industrial
	FM28V102A-TGTR			

All the above parts are Pb-free.

**Ordering Code Definitions**

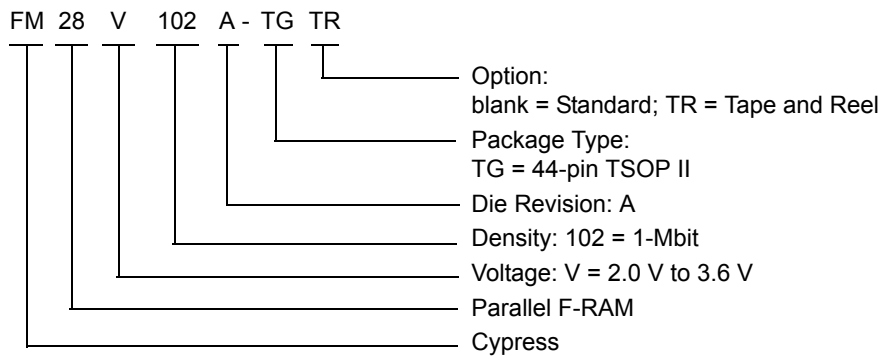



Package Diagram

Figure 15. 44-pin TSOP Package Outline, 51-85087

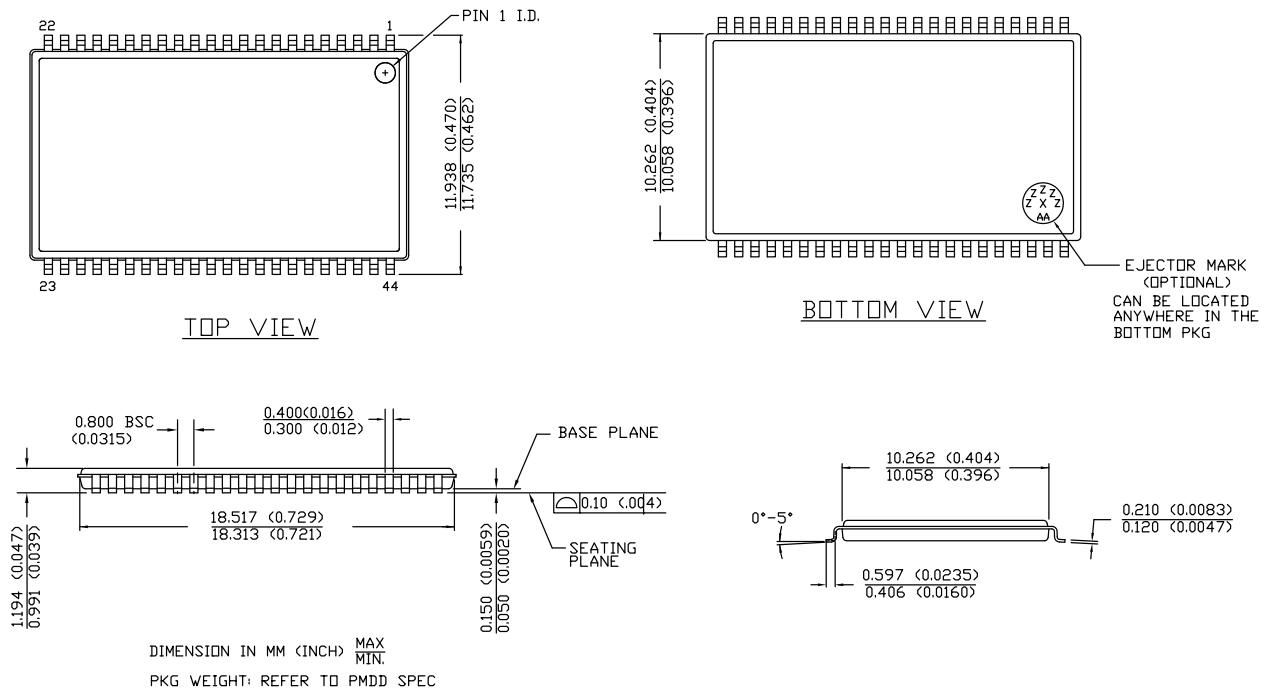

51-85087 \*E

### Acronyms

Acronym	Description
$\overline{UB}$	Upper Byte
$\overline{LB}$	Lower Byte
$\overline{CE}$	Chip Enable
CMOS	Complementary Metal Oxide Semiconductor
EIA	Electronic Industries Alliance
F-RAM	Ferroelectric Random Access Memory
I/O	Input/Output
$\overline{OE}$	Output Enable
RoHS	Restriction of Hazardous Substances
RW	Read and Write
SRAM	Static Random Access Memory
TSOP	Thin Small Outline Package
$\overline{WE}$	Write Enable

### Document Conventions

#### Units of Measure

Symbol	Unit of Measure
$^{\circ}C$	degree Celsius
Hz	hertz
kHz	kilohertz
$k\Omega$	kiloohm
MHz	megahertz
$\mu A$	microampere
$\mu F$	microfarad
$\mu s$	microsecond
mA	milliampere
ms	millisecond
$M\Omega$	megaohm
ns	nanosecond
$\Omega$	ohm
%	percent
pF	picofarad
V	volt
W	watt

**Document History Page**

Document Title: FM28V102A, 1-Mbit (64 K × 16) F-DRAM Memory				
Document Number: 001-91080				
Rev.	ECN No.	Orig. of Change	Submission Date	Description of Change
**	4272603	GVCH	03/11/2014	New data sheet.
*A	4372700	GVCH	05/07/2014	Changed datasheet status from "Preliminary to Final" <a href="#">Maximum Ratings</a> : Static discharge voltage Removed Machine Model <a href="#">DC Electrical Characteristics</a> : Updated I <sub>ZZ</sub> test condition Updated <a href="#">Figure 6</a> for more clarity Removed FM28V102A-TGES part
*B	4375244	GVCH	06/30/2014	<a href="#">Pin Definitions</a> : $\overline{\text{ZZ}}$ pin Added sentence: This pin must be tied to V <sub>DD</sub> if not used Removed sentence: The $\overline{\text{ZZ}}$ pin is internally pulled up <a href="#">DC Electrical Characteristics</a> : Removed R <sub>IN</sub> spec
*C	4562106	GVCH	11/5/2014	Added related documentation hyperlink in page 1.
*D	4683470	GVCH	03/11/2015	Typo fixed ( <a href="#">Features</a> ): Removed "Software-programmable block write-protect feature"
*E	4881722	ZSK / PSR	08/12/2015	Updated <a href="#">Maximum Ratings</a> : Removed "Maximum junction temperature". Added "Maximum accumulated storage time". Added "Ambient temperature with power applied". Updated to new template.

## Sales, Solutions, and Legal Information

### Worldwide Sales and Design Support

Cypress maintains a worldwide network of offices, solution centers, manufacturer's representatives, and distributors. To find the office closest to you, visit us at [Cypress Locations](#).

#### Products

<a href="#">Automotive</a>	<a href="#">cypress.com/go/automotive</a>
<a href="#">Clocks &amp; Buffers</a>	<a href="#">cypress.com/go/clocks</a>
<a href="#">Interface</a>	<a href="#">cypress.com/go/interface</a>
<a href="#">Lighting &amp; Power Control</a>	<a href="#">cypress.com/go/powerpsoc</a>
<a href="#">Memory</a>	<a href="#">cypress.com/go/memory</a>
<a href="#">PSoC</a>	<a href="#">cypress.com/go/psoc</a>
<a href="#">Touch Sensing</a>	<a href="#">cypress.com/go/touch</a>
<a href="#">USB Controllers</a>	<a href="#">cypress.com/go/USB</a>
<a href="#">Wireless/RF</a>	<a href="#">cypress.com/go/wireless</a>

#### PSoC<sup>®</sup> Solutions

[psoc.cypress.com/solutions](#)  
[PSoC 1](#) | [PSoC 3](#) | [PSoC 4](#) | [PSoC 5LP](#)

#### Cypress Developer Community

[Community](#) | [Forums](#) | [Blogs](#) | [Video](#) | [Training](#)

#### Technical Support

[cypress.com/go/support](#)

---

© Cypress Semiconductor Corporation, 2014-2015. The information contained herein is subject to change without notice. Cypress Semiconductor Corporation assumes no responsibility for the use of any circuitry other than circuitry embodied in a Cypress product. Nor does it convey or imply any license under patent or other rights. Cypress products are not warranted nor intended to be used for medical, life support, life saving, critical control or safety applications, unless pursuant to an express written agreement with Cypress. Furthermore, Cypress does not authorize its products for use as critical components in life-support systems where a malfunction or failure may reasonably be expected to result in significant injury to the user. The inclusion of Cypress products in life-support systems application implies that the manufacturer assumes all risk of such use and in doing so indemnifies Cypress against all charges.

Any Source Code (software and/or firmware) is owned by Cypress Semiconductor Corporation (Cypress) and is protected by and subject to worldwide patent protection (United States and foreign), United States copyright laws and international treaty provisions. Cypress hereby grants to licensee a personal, non-exclusive, non-transferable license to copy, use, modify, create derivative works of, and compile the Cypress Source Code and derivative works for the sole purpose of creating custom software and or firmware in support of licensee product to be used only in conjunction with a Cypress integrated circuit as specified in the applicable agreement. Any reproduction, modification, translation, compilation, or representation of this Source Code except as specified above is prohibited without the express written permission of Cypress.

Disclaimer: CYPRESS MAKES NO WARRANTY OF ANY KIND, EXPRESS OR IMPLIED, WITH REGARD TO THIS MATERIAL, INCLUDING, BUT NOT LIMITED TO, THE IMPLIED WARRANTIES OF MERCHANTABILITY AND FITNESS FOR A PARTICULAR PURPOSE. Cypress reserves the right to make changes without further notice to the materials described herein. Cypress does not assume any liability arising out of the application or use of any product or circuit described herein. Cypress does not authorize its products for use as critical components in life-support systems where a malfunction or failure may reasonably be expected to result in significant injury to the user. The inclusion of Cypress' product in a life-support systems application implies that the manufacturer assumes all risk of such use and in doing so indemnifies Cypress against all charges.

Use may be limited by and subject to the applicable Cypress software license agreement.



Компания «ЭлектроПласт» предлагает заключение долгосрочных отношений при поставках импортных электронных компонентов на взаимовыгодных условиях!

Наши преимущества:

- Оперативные поставки широкого спектра электронных компонентов отечественного и импортного производства напрямую от производителей и с крупнейших мировых складов;
- Поставка более 17-ти миллионов наименований электронных компонентов;
- Поставка сложных, дефицитных, либо снятых с производства позиций;
- Оперативные сроки поставки под заказ (от 5 рабочих дней);
- Экспресс доставка в любую точку России;
- Техническая поддержка проекта, помощь в подборе аналогов, поставка прототипов;
- Система менеджмента качества сертифицирована по Международному стандарту ISO 9001;
- Лицензия ФСБ на осуществление работ с использованием сведений, составляющих государственную тайну;
- Поставка специализированных компонентов (Xilinx, Altera, Analog Devices, Intersil, Interpoint, Microsemi, Aeroflex, Peregrine, Syfer, Eurofarad, Texas Instrument, Miteq, Cobham, E2V, MA-COM, Hittite, Mini-Circuits, General Dynamics и др.);

Помимо этого, одним из направлений компании «ЭлектроПласт» является направление «Источники питания». Мы предлагаем Вам помощь Конструкторского отдела:

- Подбор оптимального решения, техническое обоснование при выборе компонента;
- Подбор аналогов;
- Консультации по применению компонента;
- Поставка образцов и прототипов;
- Техническая поддержка проекта;
- Защита от снятия компонента с производства.



#### Как с нами связаться

**Телефон:** 8 (812) 309 58 32 (многоканальный)

**Факс:** 8 (812) 320-02-42

**Электронная почта:** [org@eplast1.ru](mailto:org@eplast1.ru)

**Адрес:** 198099, г. Санкт-Петербург, ул. Калинина, дом 2, корпус 4, литера А.