



Series 228C

7.2 x 6.8mm Illuminated Tactile Switch

- Surface mount gull-wing terminal and standard through hole configurations
- Compatible with IR reflow, and manual soldering
- Single, Bi-color or Tri-color display during illumination
- Variety of LED color options
- Variety of cap styles, colors, and laser etching options



Ordering Information

Series	Terminal Type	Actuating Direction	Actuation Force	LED Color	LED Type	Cap Style	Cap Color	Laser Etching	Packaging
228C	M	V	A	R	F	A	MS	A	R

Code	Spec.
D	Standard through hole (white actuator)
M	Surface mount gull wing (black actuator)

Code	Spec.
V	Vertical

Code	Spec.
A	160 gf

Code	Spec.
R	Red
Y	Yellow
G	Green
B	Blue
W	White
A	Amber
RG	Red & Green
RB	Red & Blue
YG	Yellow & Green
RA	Red & Amber
AW	Amber & White
RGB	Red, Green & Blue

Code	Spec.
F	Flat

Blank – No Cap
See table on pages 2 - 3

Note: Caps supplied in bulk for surface mount terminal constructions and must be installed after IR reflow soldering.

Code	Spec.
Blank	Blank – No Etching (only available on Natural color caps) See table on page.2

Code	Spec.
R	Tape & reel packaging (only available for surface mount type)
Blank	Tray packaging (only available for standard through hole type)

Cap Style

Code	Spec.
A	Round (Dia 7.3mm)
B	Elliptical column on round
C	Cylinder on square
D	Cylinder
E	Cylinder on round
F	Joystick button on square

Cap Etching

Code	Style
A	
B	
C	
D	OK

Cap Color

Code	Spec.
MS	Misty Silver
W	White
BB	Bright Black
R	Red
MB	Misty Black
A	Orange
N	Natural

Cap Style Details

Style A: Round (Dia.7.3mm)

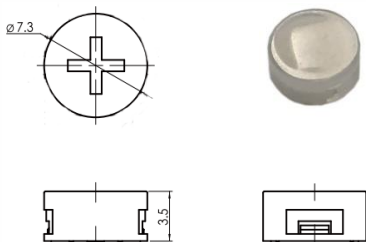

Style C: Cylinder on square

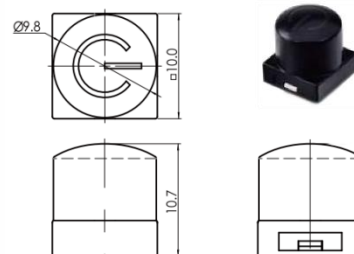

Style B: Elliptical column on round

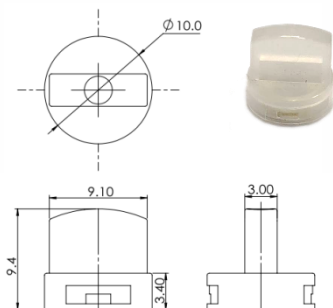

Style D: Cylinder

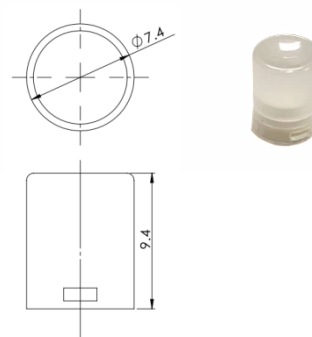

Style E: Cylinder on round

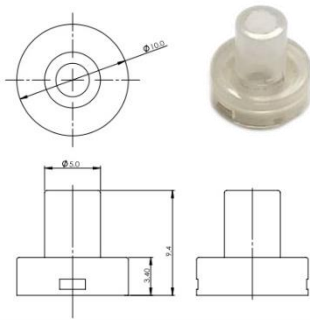

Style F: Joystick button on square

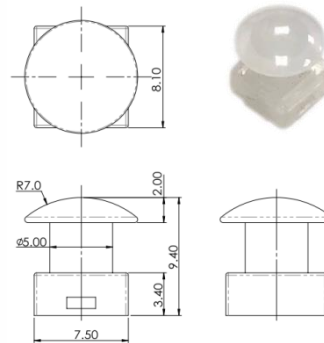

Electrical Specifications

Parameter	Conditions & Remarks	Min	Max	Unit
Contact Resistance			100	milliohms
Insulation Resistance	Between insulated terminals	100		megohms
Dielectric Strength	1 minute between adjacent switches		250	VAC
Non-switching Rating			50 or 12	mA or VDC

Mechanical and Environmental

Soldering	Maximum reflow temperature, 260°C for 5 seconds Maximum manual temperature, 350°C for 3 seconds
RoHS	Lead-Free. Fully compliant to RoHS Directive 2011/65/EU and 2015/863/EU
Operating Force	160±50 gf
Actuation Life	100,000 cycles
Actuator Strength	2 Kgf maximum
Travel	0.25±0.1mm
Packaging	Standard tape and reel packaging for surface mount gull wing terminal Tray packaging for standard through hole
Operating Temperature Range	-25°C to +70°C
Storage Temperature Range	-30°C to +80°C

Soldering Profile

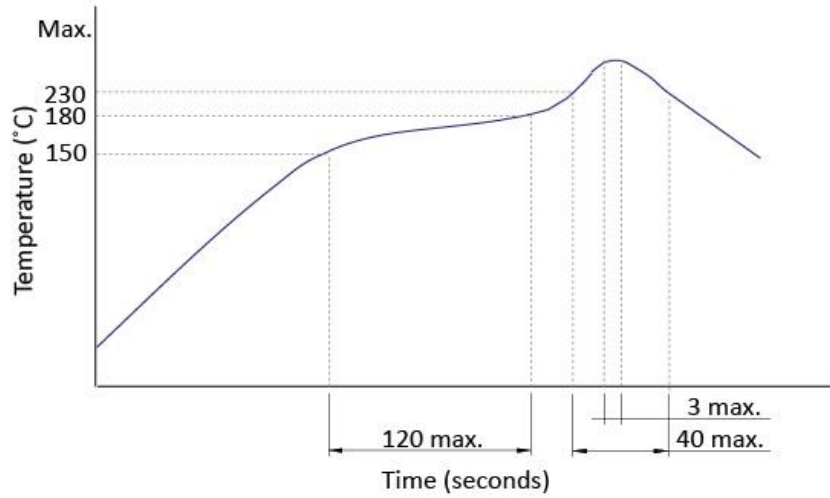

Mechanical Specifications

Figure 1 – 228CDV, Standard Though Hole, Vertical Actuation

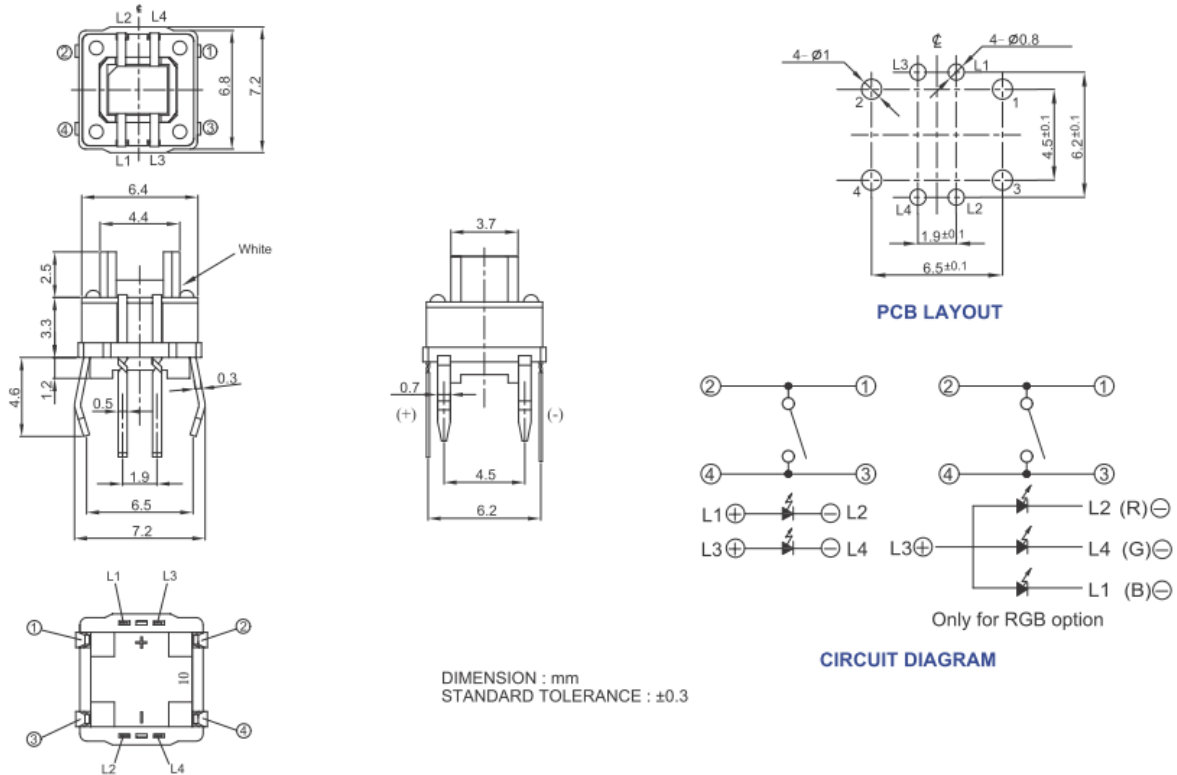

Figure 2 – 228CMV, Surface Mount Gull Wing, Vertical Actuation

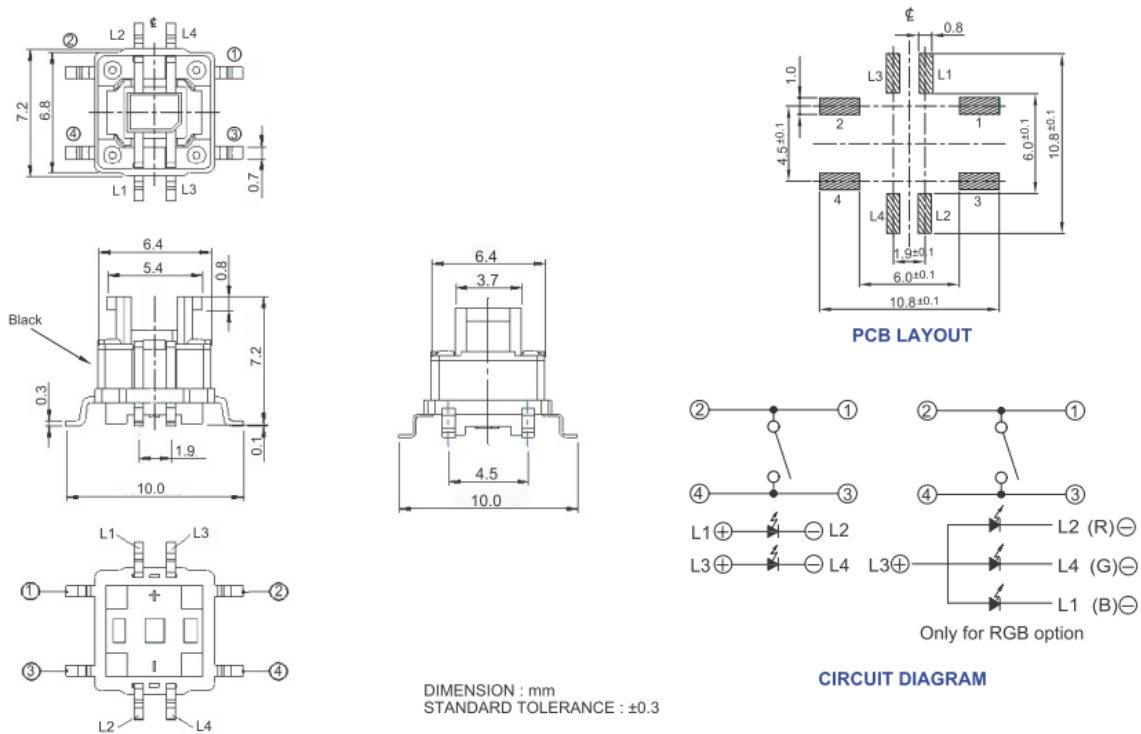

Figure 3 – 228CDV...F..., Standard Though Hole, Vertical Actuation, Joystick Button on Square

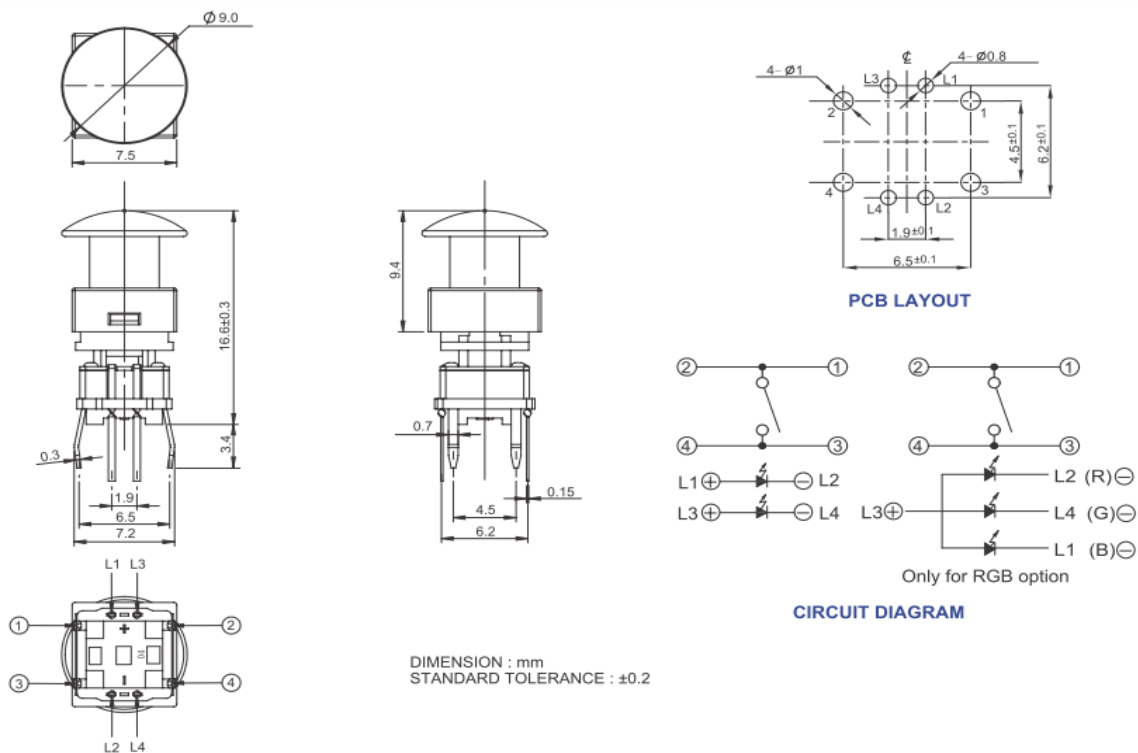
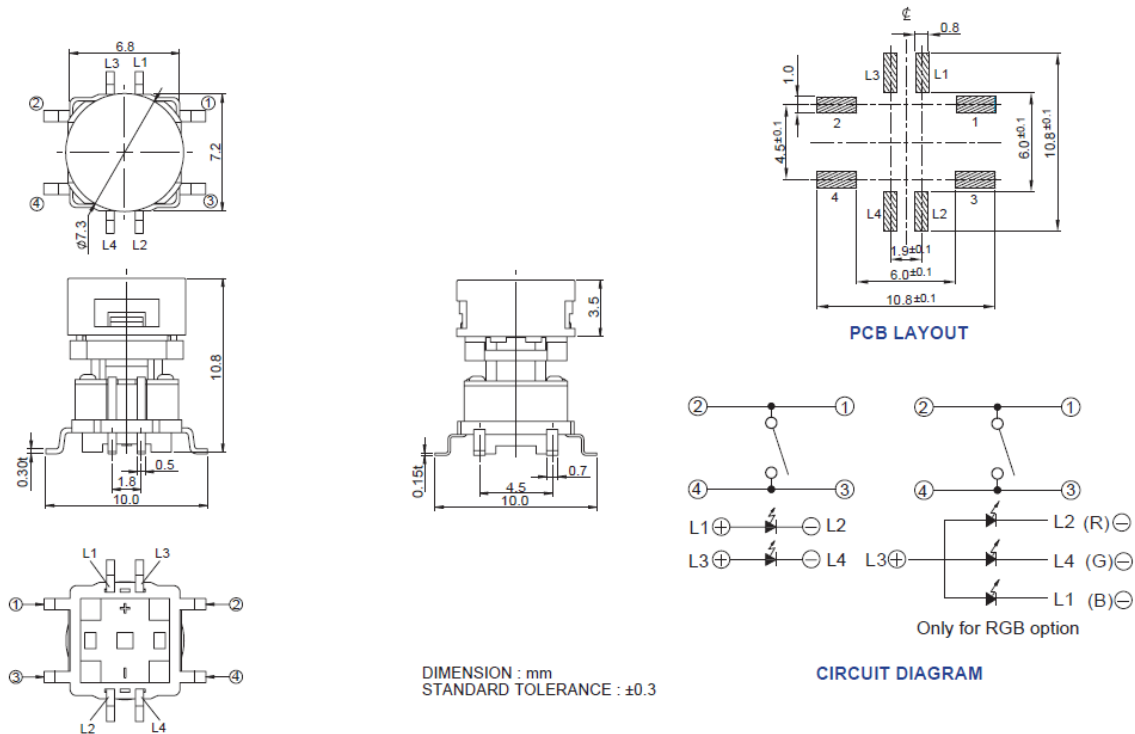

Figure 4 - 228CMV...A..., Standard Though Hole, Vertical Actuation, Round



Packing: Tape and Reel

Surface Mount Gull Wing, Actuator Height 7.0mm

The packing specifications:

1. Structure and materials:

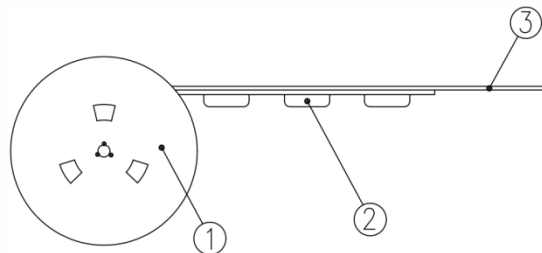

No	PART NAME	MATERIAL
①	REEL	POLYSTYRENE
②	CARRIER TAPE	POLYSTYRENE
③	COVER TAPE	POLYESTER

2. Packing quantity: 450 pcs/reel
3. More than 15 empty pockets should remain at each end of the carrier tape for each reel.
4. Shortage of less than 10 pcs a reel is acceptable but no more than 3 consecutive empty pockets are allowed.
5. Stripping strength of cover tape is between 10 gf to 130 gf and stripping angle should be within 165°~180°.
6. The product in the pocket of carrier tape should be placed in a specified correct position.
7. Tape and reel per EIA-481.
8. Dimensions:

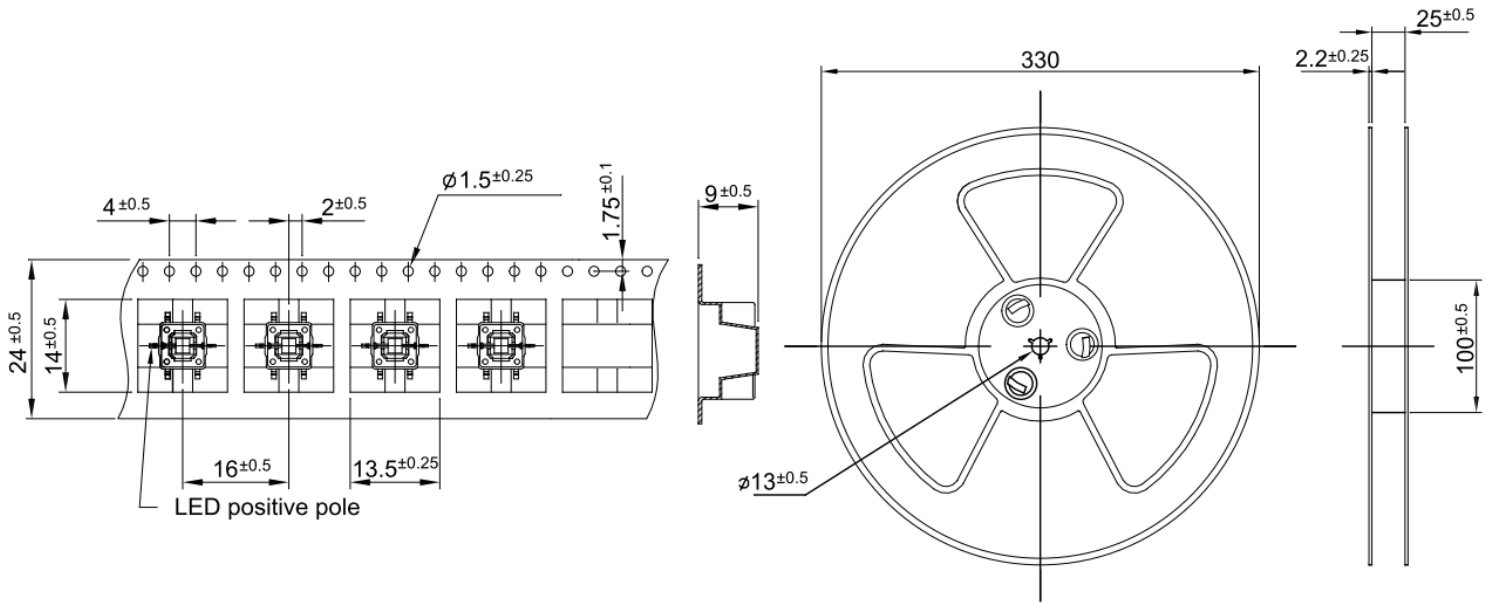



Компания «ЭлектроПласт» предлагает заключение долгосрочных отношений при поставках импортных электронных компонентов на взаимовыгодных условиях!

Наши преимущества:

- Оперативные поставки широкого спектра электронных компонентов отечественного и импортного производства напрямую от производителей и с крупнейших мировых складов;
- Поставка более 17-ти миллионов наименований электронных компонентов;
- Поставка сложных, дефицитных, либо снятых с производства позиций;
- Оперативные сроки поставки под заказ (от 5 рабочих дней);
- Экспресс доставка в любую точку России;
- Техническая поддержка проекта, помощь в подборе аналогов, поставка прототипов;
- Система менеджмента качества сертифицирована по Международному стандарту ISO 9001;
- Лицензия ФСБ на осуществление работ с использованием сведений, составляющих государственную тайну;
- Поставка специализированных компонентов (Xilinx, Altera, Analog Devices, Intersil, Interpoint, Microsemi, Aeroflex, Peregrine, Syfer, Eurofarad, Texas Instrument, Miteq, Cobham, E2V, MA-COM, Hittite, Mini-Circuits, General Dynamics и др.);

Помимо этого, одним из направлений компании «ЭлектроПласт» является направление «Источники питания». Мы предлагаем Вам помощь Конструкторского отдела:

- Подбор оптимального решения, техническое обоснование при выборе компонента;
- Подбор аналогов;
- Консультации по применению компонента;
- Поставка образцов и прототипов;
- Техническая поддержка проекта;
- Защита от снятия компонента с производства.



Как с нами связаться

Телефон: 8 (812) 309 58 32 (многоканальный)

Факс: 8 (812) 320-02-42

Электронная почта: org@eplast1.ru

Адрес: 198099, г. Санкт-Петербург, ул. Калинина, дом 2, корпус 4, литера А.