

## 1M x 8 HIGH-SPEED ASYNCHRONOUS CMOS STATIC RAM WITH ECC

FEBRUARY 2013

### FEATURES

- High-speed access times: 8, 10, 20 ns
- High-performance, low-power CMOS process
- Multiple center power and ground pins for greater noise immunity
- Easy memory expansion with  $\overline{CE}$  and  $\overline{OE}$  options
- $\overline{CE}$  power-down
- Fully static operation: no clock or refresh required
- TTL compatible inputs and outputs
- Packages available:
  - 48-ball miniBGA (6mm x 8mm)
  - 44-pin TSOP (Type II)
- Industrial and Automotive Temperature Support
- Lead-free available

### DESCRIPTION

The *ISSI* IS61/64WV10248EDBLL are very high-speed, low power, 1M-word by 8-bit CMOS static RAM. The IS61/64WV10248EDBLL are fabricated using *ISSI*'s high-performance CMOS technology. This highly reliable process coupled with innovative circuit design techniques, yields higher performance and low power consumption devices.

When  $\overline{CE}$  is HIGH (deselected), the device assumes a standby mode at which the power dissipation can be reduced down with CMOS input levels.

The IS61/64WV10248EDBLL operate from a single power supply and all inputs are TTL-compatible.

The IS61/64WV10248EDBLL are available in 48 ball mini BGA (6mm x 8mm) and 44-pin TSOP (Type II) packages.

### FUNCTIONAL BLOCK DIAGRAM

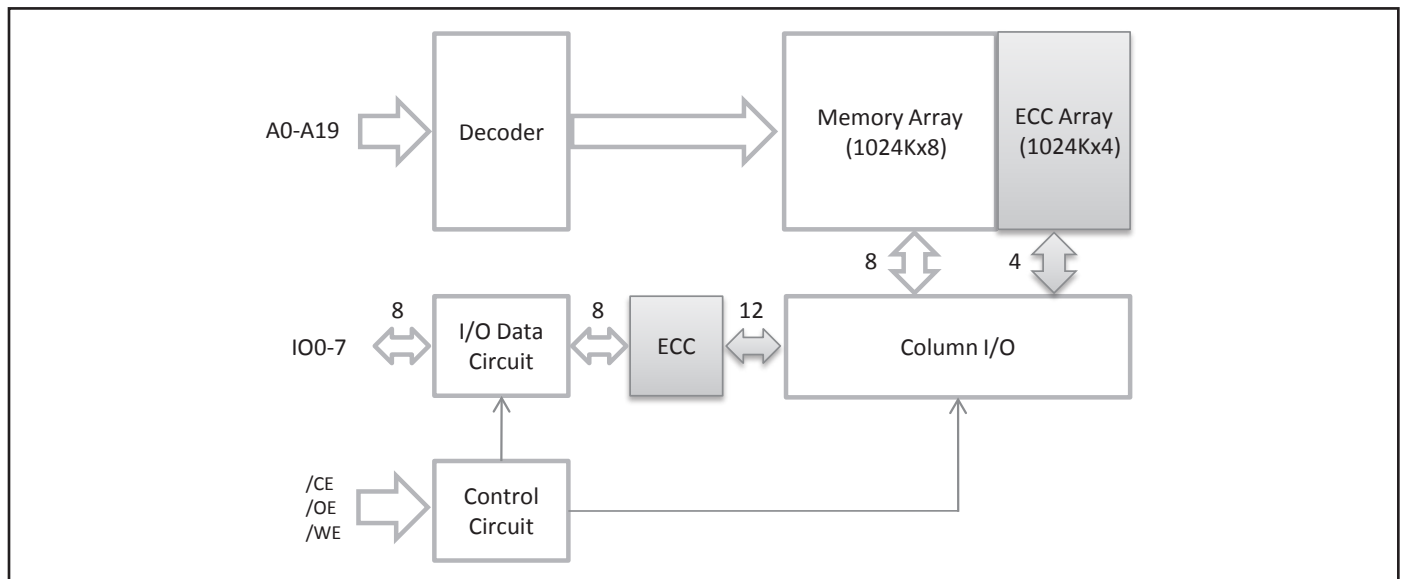

Copyright © 2013 Integrated Silicon Solution, Inc. All rights reserved. ISSI reserves the right to make changes to this specification and its products at any time without notice. ISSI assumes no liability arising out of the application or use of any information, products or services described herein. Customers are advised to obtain the latest version of this device specification before relying on any published information and before placing orders for products.

Integrated Silicon Solution, Inc. does not recommend the use of any of its products in life support applications where the failure or malfunction of the product can reasonably be expected to cause failure of the life support system or to significantly affect its safety or effectiveness. Products are not authorized for use in such applications unless Integrated Silicon Solution, Inc. receives written assurance to its satisfaction, that:

- a.) the risk of injury or damage has been minimized;
- b.) the user assume all such risks; and
- c.) potential liability of Integrated Silicon Solution, Inc is adequately protected under the circumstances

## PIN CONFIGURATION

### 48-pin Mini BGA (B) (6mm x 8mm)

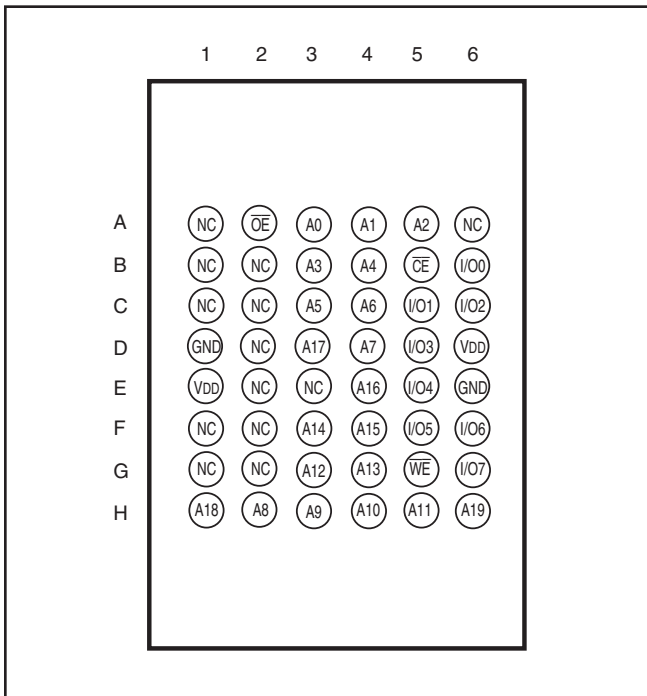

### 44-pin TSOP (Type II)

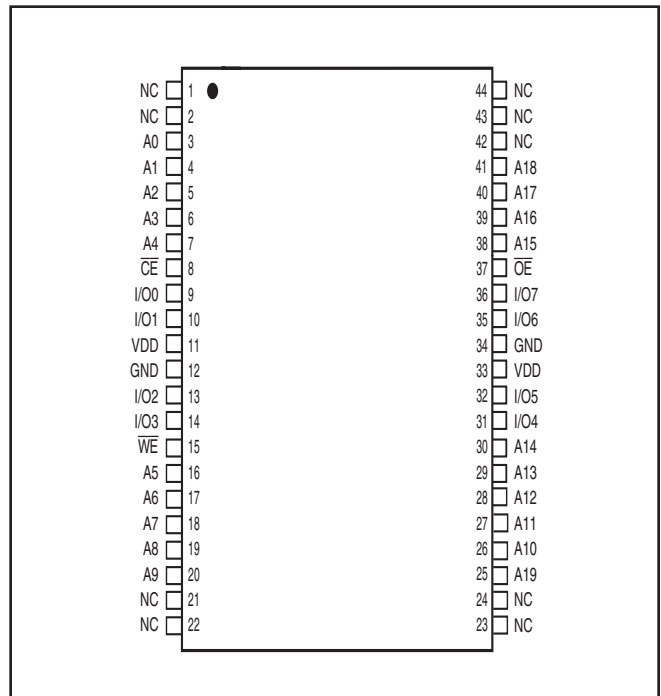

## PIN DESCRIPTIONS

A0-A19	Address Inputs
$\overline{CE}$	Chip Enable Input
$\overline{OE}$	Output Enable Input
$\overline{WE}$	Write Enable Input
I/O0-I/O7	Data Input / Output
VDD	Power
GND	Ground
NC	No Connection

## TRUTH TABLE

Mode	$\overline{WE}$	$\overline{CE}$	$\overline{OE}$	I/O Operation	V <sub>DD</sub> Current
Not Selected (Power-down)	X	H	X	High-Z	I <sub>SB1</sub> , I <sub>SB2</sub>
Output Disabled	H	L	H	High-Z	I <sub>CC</sub>
Read	H	L	L	D <sub>OUT</sub>	I <sub>CC</sub>
Write	L	L	X	D <sub>IN</sub>	I <sub>CC</sub>

## ABSOLUTE MAXIMUM RATINGS<sup>(1)</sup>

Symbol	Parameter	Value	Unit
V <sub>TERM</sub>	Terminal Voltage with Respect to GND	-0.5 to V <sub>DD</sub> + 0.5	V
V <sub>DD</sub>	V <sub>DD</sub> Relates to GND	-0.3 to 4.0	V
T <sub>STG</sub>	Storage Temperature	-65 to +150	°C
P <sub>T</sub>	Power Dissipation	1.0	W

### Notes:

1. Stress greater than those listed under ABSOLUTE MAXIMUM RATINGS may cause permanent damage to the device. This is a stress rating only and functional operation of the device at these or any other conditions above those indicated in the operational sections of this specification is not implied. Exposure to absolute maximum rating conditions for extended periods may affect reliability.

## CAPACITANCE<sup>(1,2)</sup>

Symbol	Parameter	Conditions	Max.	Unit
C <sub>IN</sub>	Input Capacitance	V <sub>IN</sub> = 0V	6	pF
C <sub>I/O</sub>	Input/Output Capacitance	V <sub>OUT</sub> = 0V	8	pF

### Notes:

1. Tested initially and after any design or process changes that may affect these parameters.
2. Test conditions: T<sub>A</sub> = 25°C, f = 1 MHz, V<sub>DD</sub> = 3.3V.

### OPERATING RANGE (V<sub>DD</sub>)<sup>1</sup>

Range	Ambient Temperature	IS61WV10248EDBLL V <sub>DD</sub> (8, 10ns)	IS64WV10248EDBLL V <sub>DD</sub> (10ns)
Industrial	-40°C to +85°C	2.4V-3.6V	—
Automotive (A1)	-40°C to +85°C	—	2.4V-3.6V
Automotive (A3)	-40°C to +125°C	—	2.4V-3.6V

**Note:**

1. Contact SRAM@issi.com for 1.8V option

### ERROR DETECTION AND ERROR CORRECTION

- Independent ECC with hamming code for each byte
- Detect and correct one bit error per byte
- Better reliability than parity code schemes which can only detect an error but not correct an error
- Backward Compatible: Drop in replacement to current in industry standard devices (without ECC)

**DC ELECTRICAL CHARACTERISTICS** (Over Operating Range)

$V_{DD} = 2.4V-3.6V$

Symbol	Parameter	Test Conditions	Min.	Max.	Unit
$V_{OH}$	Output HIGH Voltage	$V_{DD} = \text{Min.}, I_{OH} = -1.0 \text{ mA}$	1.8	—	V
$V_{OL}$	Output LOW Voltage	$V_{DD} = \text{Min.}, I_{OL} = 1.0 \text{ mA}$	—	0.4	V
$V_{IH}$	Input HIGH Voltage		2.0	$V_{DD} + 0.3$	V
$V_{IL}$	Input LOW Voltage <sup>(1)</sup>		-0.3	0.8	V
$I_{LI}$	Input Leakage	$GND \leq V_{IN} \leq V_{DD}$	-1	1	$\mu A$
$I_{LO}$	Output Leakage	$GND \leq V_{OUT} \leq V_{DD}$ , Outputs Disabled	-1	1	$\mu A$

**Note:**

- $V_{IL} (\text{min.}) = -0.3V \text{ DC}; V_{IL} (\text{min.}) = -2.0V \text{ AC}$  (pulse width  $\leq 2 \text{ ns}$ ). Not 100% tested.  
 $V_{IH} (\text{max.}) = V_{DD} + 0.3V \text{ DC}; V_{IH} (\text{max.}) = V_{DD} + 2.0V \text{ AC}$  (pulse width  $\leq 2 \text{ ns}$ ). Not 100% tested.

**AC TEST CONDITIONS (HIGH SPEED)**

Parameter	Unit (2.4V-3.6V)
Input Pulse Level	0.4V to $V_{DD}-0.3V$
Input Rise and Fall Times	1.5ns
Input and Output Timing and Reference Level ( $V_{Ref}$ )	$V_{DD}/2$
Output Load	See Figures 1 and 2

**AC TEST LOADS**

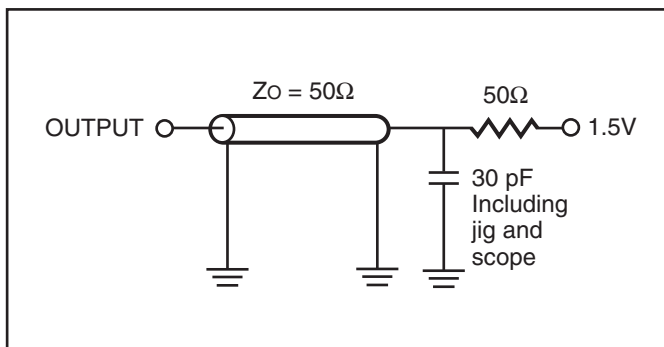

Figure 1.

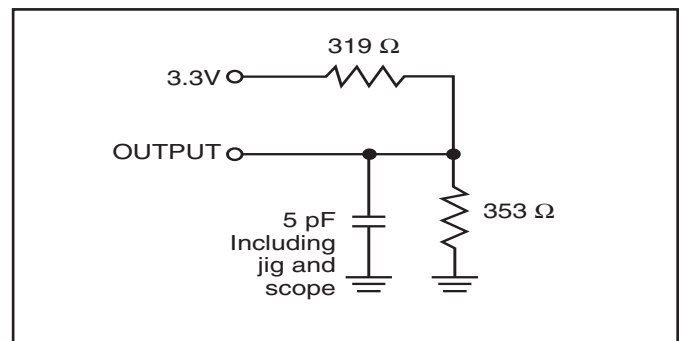

Figure 2.

**POWER SUPPLY CHARACTERISTICS<sup>(1)</sup>** (Over Operating Range)

Symbol	Parameter	Test Conditions		-8		-10		-20		Unit
				Min.	Max.	Min.	Max.	Min.	Max.	
I <sub>CC</sub>	V <sub>DD</sub> Dynamic Operating Supply Current	V <sub>DD</sub> = Max., I <sub>OUT</sub> = 0 mA, f = f <sub>MAX</sub>	Com.	—	45	—	40	—	30	mA
			Ind.	—	55	—	50	—	40	
			Auto.	—	—	—	65	—	55	
			typ. <sup>(2)</sup>			15				
I <sub>CC1</sub>	Operating Supply Current	V <sub>DD</sub> = Max., I <sub>OUT</sub> = 0 mA, f = 0	Com.	—	20	—	20	—	20	mA
			Ind.	—	25	—	25	—	25	
			Auto.	—	—	—	50	—	50	
I <sub>SB1</sub>	TTL Standby Current (TTL Inputs)	V <sub>DD</sub> = Max., V <sub>IN</sub> = V <sub>IH</sub> or V <sub>IL</sub> $\overline{CE} \geq V_{IH}$ , f = 0	Com.	—	20	—	20	—	20	mA
			Ind.	—	25	—	25	—	25	
			Auto.	—	—	—	45	—	45	
I <sub>SB2</sub>	CMOS Standby Current (CMOS Inputs)	V <sub>DD</sub> = Max., $\overline{CE} \geq V_{DD} - 0.2V$ , V <sub>IN</sub> ≥ V <sub>DD</sub> - 0.2V, or V <sub>IN</sub> ≤ 0.2V, f = 0	Com.	—	10	—	10	—	10	mA
			Ind.	—	15	—	15	—	15	
			Auto.	—	—	—	35	—	35	
			typ. <sup>(2)</sup>			2				

**Note:**

1. At f = f<sub>MAX</sub>, address and data inputs are cycling at the maximum frequency, f = 0 means no input lines change.
2. Typical values are measured at V<sub>DD</sub> = 3.0V, T<sub>A</sub> = 25°C and not 100% tested.

**READ CYCLE SWITCHING CHARACTERISTICS<sup>(1)</sup>** (Over Operating Range)

Symbol	Parameter	-8		-10		Unit
		Min.	Max.	Min.	Max.	
t <sub>RC</sub>	Read Cycle Time	8	—	10	—	ns
t <sub>AA</sub>	Address Access Time	—	8	—	10	ns
t <sub>OHA</sub>	Output Hold Time	2.5	—	2.5	—	ns
t <sub>ACE</sub>	$\overline{CE}$ Access Time	—	8	—	10	ns
t <sub>DOE</sub>	$\overline{OE}$ Access Time	—	5.5	—	6.5	ns
t <sub>HZOE<sup>(2)</sup></sub>	$\overline{OE}$ to High-Z Output	—	3	—	4	ns
t <sub>LZOE<sup>(2)</sup></sub>	$\overline{OE}$ to Low-Z Output	0	—	0	—	ns
t <sub>HZCE<sup>(2)</sup></sub>	$\overline{CE}$ to High-Z Output	0	3	0	4	ns
t <sub>LZCE<sup>(2)</sup></sub>	$\overline{CE}$ to Low-Z Output	3	—	3	—	ns
t <sub>PU</sub>	Power Up Time	0	—	0	—	ns
t <sub>PD</sub>	Power Down Time	—	8	—	10	ns

**Notes:**

1. Test conditions and output loading conditions are specified in the AC Test Conditions and AC Test Loads (Figure 1).
2. Tested with the load in Figure 2. Transition is measured  $\pm 500$  mV from steady-state voltage.

**READ CYCLE SWITCHING CHARACTERISTICS<sup>(1)</sup> (Over Operating Range)**

Symbol	Parameter	-20 ns		Unit
		Min.	Max.	
t <sub>RC</sub>	Read Cycle Time	20	—	ns
t <sub>AA</sub>	Address Access Time	—	20	ns
t <sub>OHA</sub>	Output Hold Time	2.5	—	ns
t <sub>ACE</sub>	$\overline{CE}$ Access Time	—	20	ns
t <sub>DOE</sub>	$\overline{OE}$ Access Time	—	8	ns
t <sub>HZOE<sup>(2)</sup></sub>	$\overline{OE}$ to High-Z Output	0	8	ns
t <sub>LZOE<sup>(2)</sup></sub>	$\overline{OE}$ to Low-Z Output	0	—	ns
t <sub>HZCE<sup>(2)</sup></sub>	$\overline{CE}$ to High-Z Output	0	8	ns
t <sub>LZCE<sup>(2)</sup></sub>	$\overline{CE}$ to Low-Z Output	3	—	ns
t <sub>PU</sub>	Power Up Time	0	—	ns
t <sub>PD</sub>	Power Down Time	—	20	ns

**Notes:**

1. Test conditions and output loading conditions are specified in the AC Test Conditions and AC Test Loads (Figure 1).
2. Tested with the load in Figure 2. Transition is measured  $\pm 500$  mV from steady-state voltage. Not 100% tested.
3. Not 100% tested.



**AC WAVEFORMS**

**READ CYCLE NO. 1<sup>(1,2)</sup>** (Address Controlled) ( $\overline{CE} = \overline{OE} = V_{IL}$ )



**READ CYCLE NO. 2<sup>(1,3)</sup>** ( $\overline{CE}$  and  $\overline{OE}$  Controlled)



**Notes:**

1.  $\overline{WE}$  is HIGH for a Read Cycle.
2. The device is continuously selected.  $\overline{OE}, \overline{CE} = V_{IL}$ .
3. Address is valid prior to or coincident with  $\overline{CE}$  LOW transitions.

**WRITE CYCLE SWITCHING CHARACTERISTICS<sup>(1,3)</sup>** (Over Operating Range)

Symbol	Parameter	-8		-10		Unit
		Min.	Max.	Min.	Max.	
t <sub>WC</sub>	Write Cycle Time	8	—	10	—	ns
t <sub>SCE</sub>	$\overline{CE}$ to Write End	6.5	—	8	—	ns
t <sub>AW</sub>	Address Setup Time to Write End	6.5	—	8	—	ns
t <sub>HA</sub>	Address Hold from Write End	0	—	0	—	ns
t <sub>SA</sub>	Address Setup Time	0	—	0	—	ns
t <sub>PWE1</sub>	$\overline{WE}$ Pulse Width ( $\overline{OE}$ = HIGH)	6.5	—	8	—	ns
t <sub>PWE2</sub>	$\overline{WE}$ Pulse Width ( $\overline{OE}$ = LOW)	8.0	—	10	—	ns
t <sub>SD</sub>	Data Setup to Write End	5	—	6	—	ns
t <sub>HD</sub>	Data Hold from Write End	0	—	0	—	ns
t <sub>HZWE<sup>(2)</sup></sub>	$\overline{WE}$ LOW to High-Z Output	—	3.5	—	5	ns
t <sub>LZWE<sup>(2)</sup></sub>	$\overline{WE}$ HIGH to Low-Z Output	2	—	2	—	ns

**Notes:**

1. Test conditions and output loading conditions are specified in the AC Test Conditions and AC Test Loads (Figure 1).
2. Tested with the load in Figure 2. Transition is measured  $\pm 500$  mV from steady-state voltage. Not 100% tested.
3. The internal write time is defined by the overlap of  $\overline{CE}$  LOW and  $\overline{WE}$  LOW. All signals must be in valid states to initiate a Write, but any one can go inactive to terminate the Write. The Data Input Setup and Hold timing are referenced to the rising or falling edge of the signal that terminates the write. Shaded area product in development

**WRITE CYCLE SWITCHING CHARACTERISTICS<sup>(1,2)</sup>** (Over Operating Range)

Symbol	Parameter	-20 ns		Unit
		Min.	Max.	
t <sub>WC</sub>	Write Cycle Time	20	—	ns
t <sub>SCE</sub>	$\overline{CE}$ to Write End	12	—	ns
t <sub>AW</sub>	Address Setup Time to Write End	12	—	ns
t <sub>HA</sub>	Address Hold from Write End	0	—	ns
t <sub>SA</sub>	Address Setup Time	0	—	ns
t <sub>PWE1</sub>	$\overline{WE}$ Pulse Width ( $\overline{OE}$ = HIGH)	12	—	ns
t <sub>PWE2</sub>	$\overline{WE}$ Pulse Width ( $\overline{OE}$ = LOW)	17	—	ns
t <sub>SD</sub>	Data Setup to Write End	9	—	ns
t <sub>HD</sub>	Data Hold from Write End	0	—	ns
t <sub>HZWE<sup>(2)</sup></sub>	$\overline{WE}$ LOW to High-Z Output	—	9	ns
t <sub>LZWE<sup>(2)</sup></sub>	$\overline{WE}$ HIGH to Low-Z Output	3	—	ns

**Notes:**

1. Test conditions and output loading conditions are specified in the AC Test Conditions and AC Test Loads (Figure 1).
2. Tested with the load in Figure 2. Transition is measured  $\pm 500$  mV from steady-state voltage. Not 100% tested.
3. The internal write time is defined by the overlap of  $\overline{CE}$  LOW and  $\overline{WE}$  LOW. All signals must be in valid states to initiate a Write, but any one can go inactive to terminate the Write. The Data Input Setup and Hold timing are referenced to the rising or falling edge of the signal that terminates the write.

**AC WAVEFORMS**

**WRITE CYCLE NO. 1**<sup>(1,2)</sup> ( $\overline{CE}$  Controlled,  $\overline{OE}$  = HIGH or LOW)

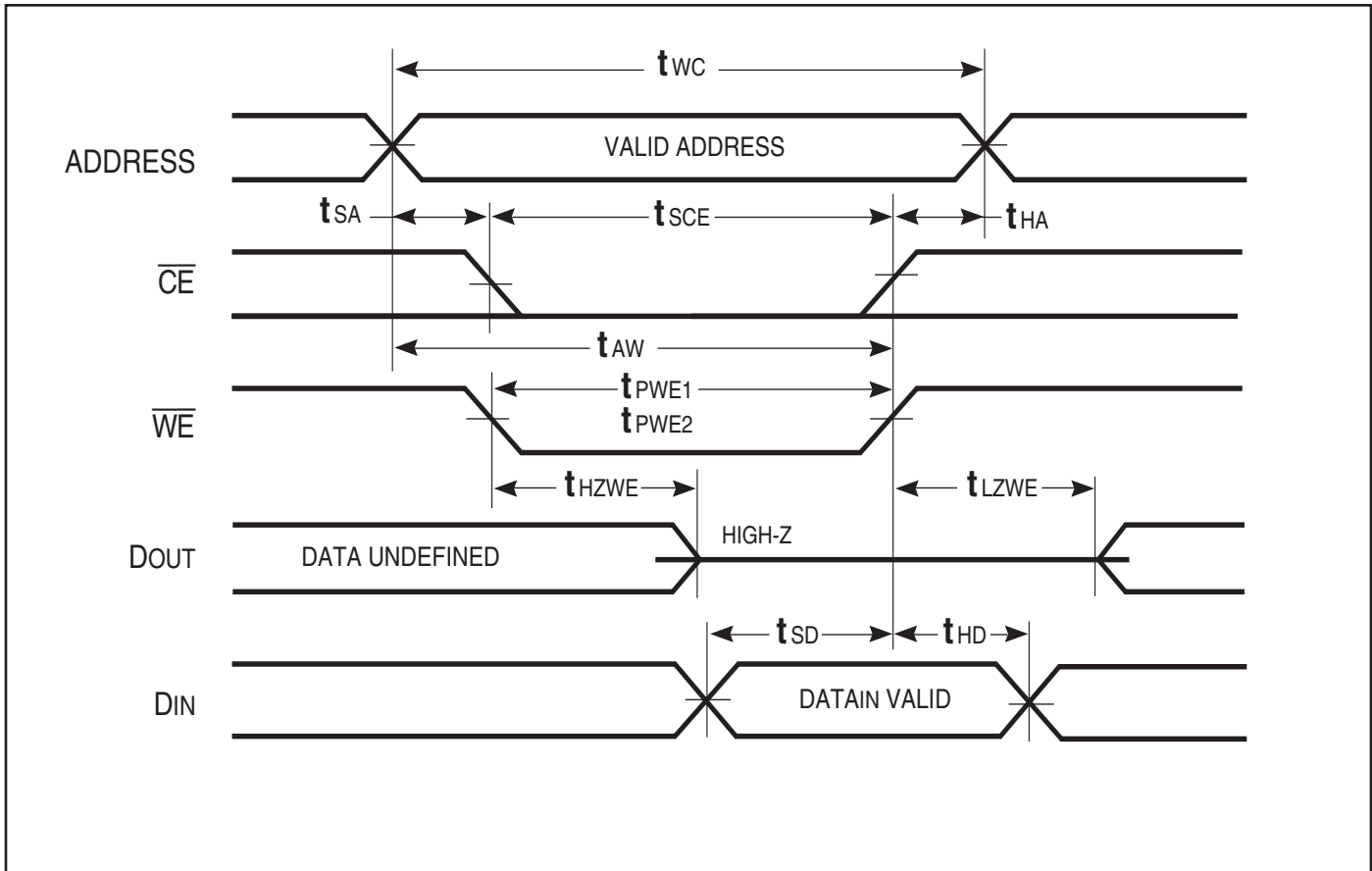

AC WAVEFORMS

WRITE CYCLE NO. 2<sup>(1,2)</sup> ( $\overline{WE}$  Controlled:  $\overline{OE}$  is HIGH During Write Cycle)



Notes:

1. The internal write time is defined by the overlap of  $\overline{CE}$  LOW and  $\overline{WE}$  LOW. All signals must be in valid states to initiate a Write, but any one can go inactive to terminate the Write. The Data Input Setup and Hold timing are referenced to the rising or falling edge of the signal that terminates the Write.
2. I/O will assume the High-Z state if  $\overline{OE} > V_{IH}$ .

AC WAVEFORMS

WRITE CYCLE NO. 3 ( $\overline{WE}$  Controlled:  $\overline{OE}$  is LOW During Write Cycle)

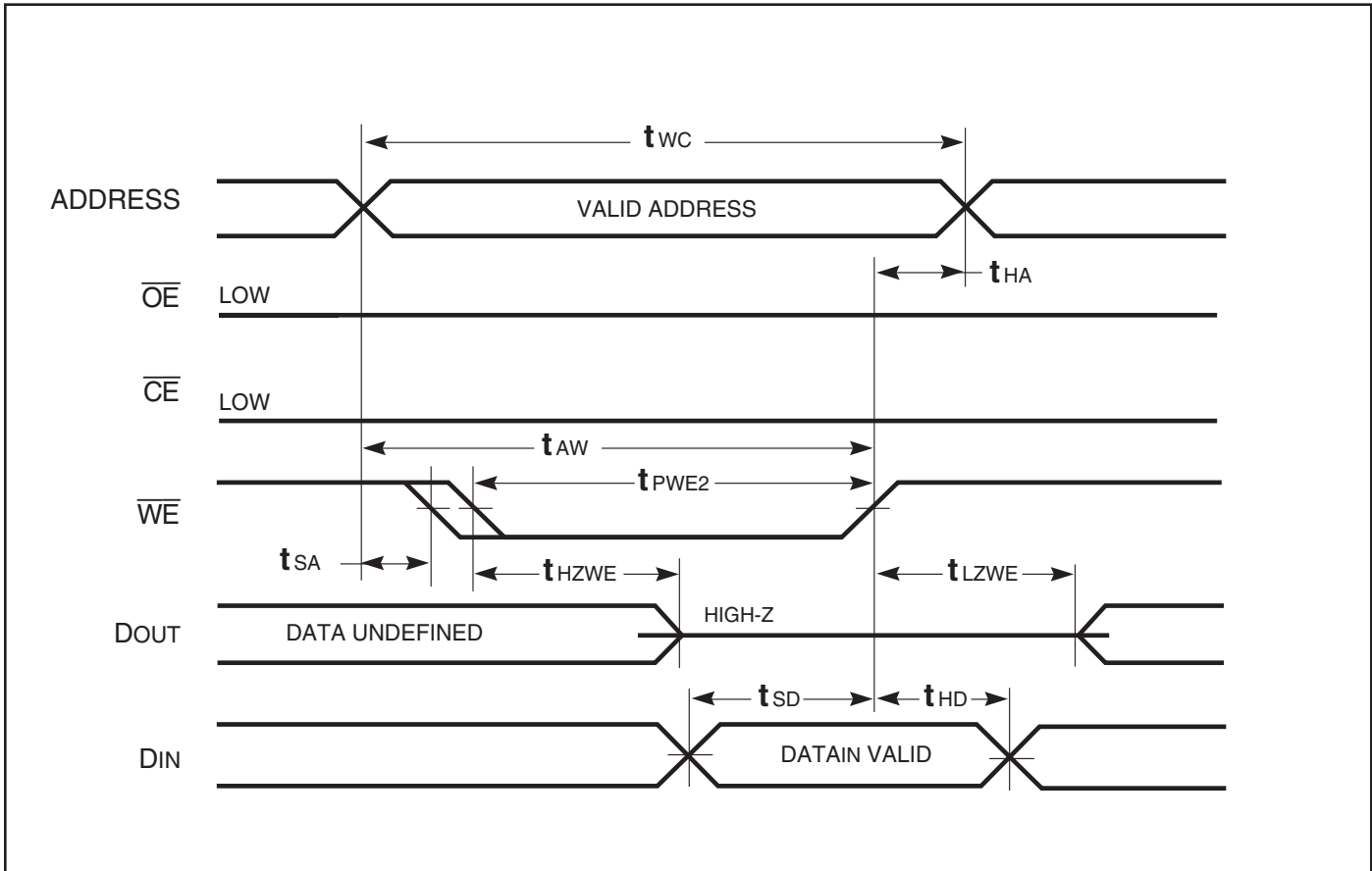

**DATA RETENTION SWITCHING CHARACTERISTICS (2.4V-3.6V)**

Symbol	Parameter	Test Condition	Options	Min.	Typ. <sup>(1)</sup>	Max.	Unit
V <sub>DR</sub>	V <sub>DD</sub> for Data Retention	See Data Retention Waveform		2.0	—	3.6	V
I <sub>DR</sub>	Data Retention Current	V <sub>DD</sub> = 2.0V, $\overline{CE} \geq V_{DD} - 0.2V$	Com. Ind. Auto.	—	2	10 15 35	mA
t <sub>SDR</sub>	Data Retention Setup Time	See Data Retention Waveform		0	—	—	ns
t <sub>RDR</sub>	Recovery Time	See Data Retention Waveform		t <sub>RC</sub>	—	—	ns

**Note 1:** Typical values are measured at V<sub>DD</sub> = V<sub>DR</sub>(min), T<sub>A</sub> = 25°C and not 100% tested.

**DATA RETENTION WAVEFORM ( $\overline{CE}$  Controlled)**

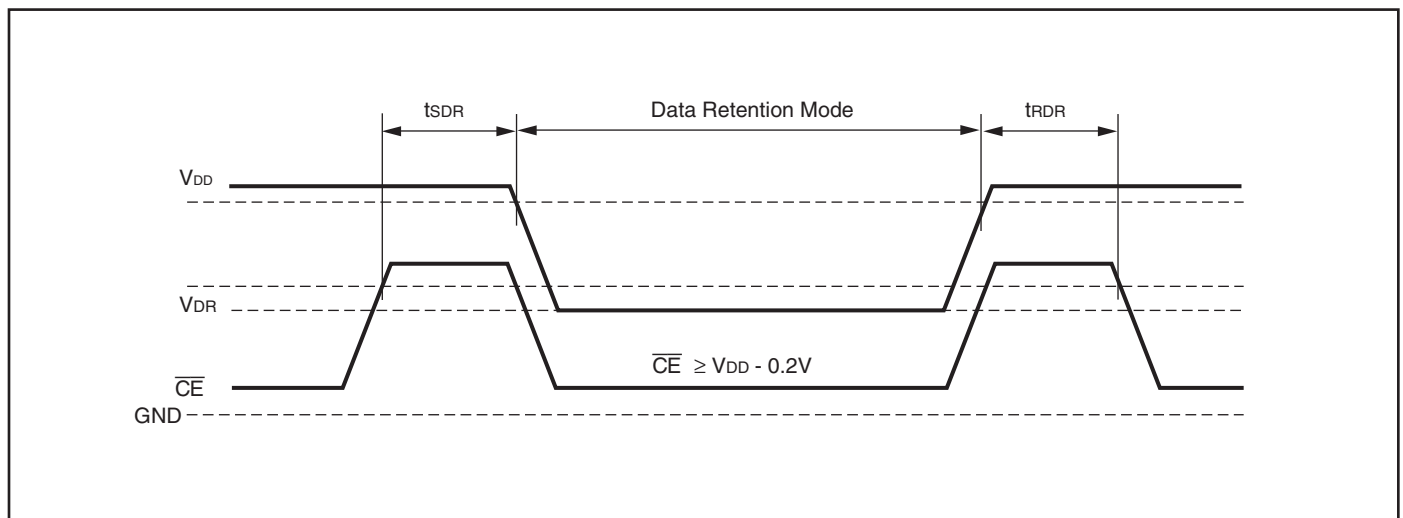

## ORDERING INFORMATION

**Industrial Range: -40°C to +85°C**

**Voltage Range: 2.4V to 3.6V**

Speed (ns)	Order Part No.	Package
8	IS61WV10248EDBLL-8BLI	48 mini BGA (6mm x 8mm), Lead-free
	IS61WV10248EDBLL-8TLI	TSOP (Type II), Lead-free
10	IS61WV10248EDBLL-10BI	48 mini BGA (6mm x 8mm)
	IS61WV10248EDBLL-10BLI	48 mini BGA (6mm x 8mm), Lead-free
	IS61WV10248EDBLL-10TI	TSOP (Type II)
	IS61WV10248EDBLL-10TLI	TSOP (Type II), Lead-free

**Automotive Range: -40°C to +125°C**

**Voltage Range: 2.4V to 3.6V**

Speed (ns)	Order Part No.	Package
10	IS64WV10248EDBLL-10BA3	48 mini BGA (6mm x 8mm)
	IS64WV10248EDBLL-10BLA3	48 mini BGA (6mm x 8mm), Lead-free
	IS64WV10248EDBLL-10CTA3	TSOP (Type II), Copper Leadframe
	IS64WV10248EDBLL-10CTLA3	TSOP (Type II), Lead-free, Copper Leadframe



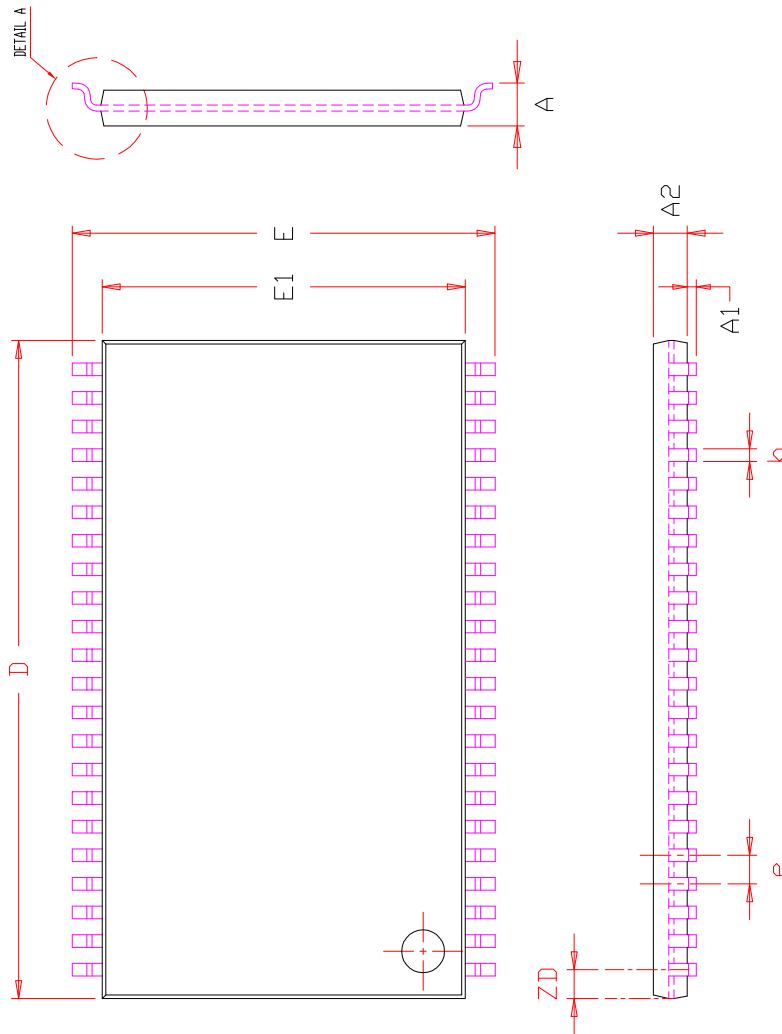

SYMBOL	DIMENSION IN MM			DIMENSION IN INCH		
	MIN.	NOM.	MAX.	MIN.	NOM.	MAX.
A	1.00		1.20	0.039		0.047
A1	0.05		0.15	0.002		0.006
A2	0.95	1.00	1.05	0.037	0.039	0.041
b	0.30		0.45	0.012		0.018
D	18.28	18.41	18.54	0.720	0.725	0.730
E	11.56	11.76	11.96	0.455	0.463	0.471
E1	10.03	10.16	10.29	0.395	0.400	0.405
e		0.80 BSC.			0.031 BSC.	
L	0.40		0.69	0.016		0.027
L1		0.25 BSC.			0.010 BSC.	
ZD		0.805 REF.			0.032 REF.	
⊕	0		8°	0		8°

**NOTE :**

1. CONTROLLING DIMENSION : MM
2. DIMENSION D AND E1 DO NOT INCLUDE MOLD PROTRUSION.
3. DIMENSION b DOES NOT INCLUDE DAMBAR PROTRUSION/INTRUSION.



	TITLE	44L 400mil TSOP-2 Package Outline	REV.	F	DATE	06/04/2008

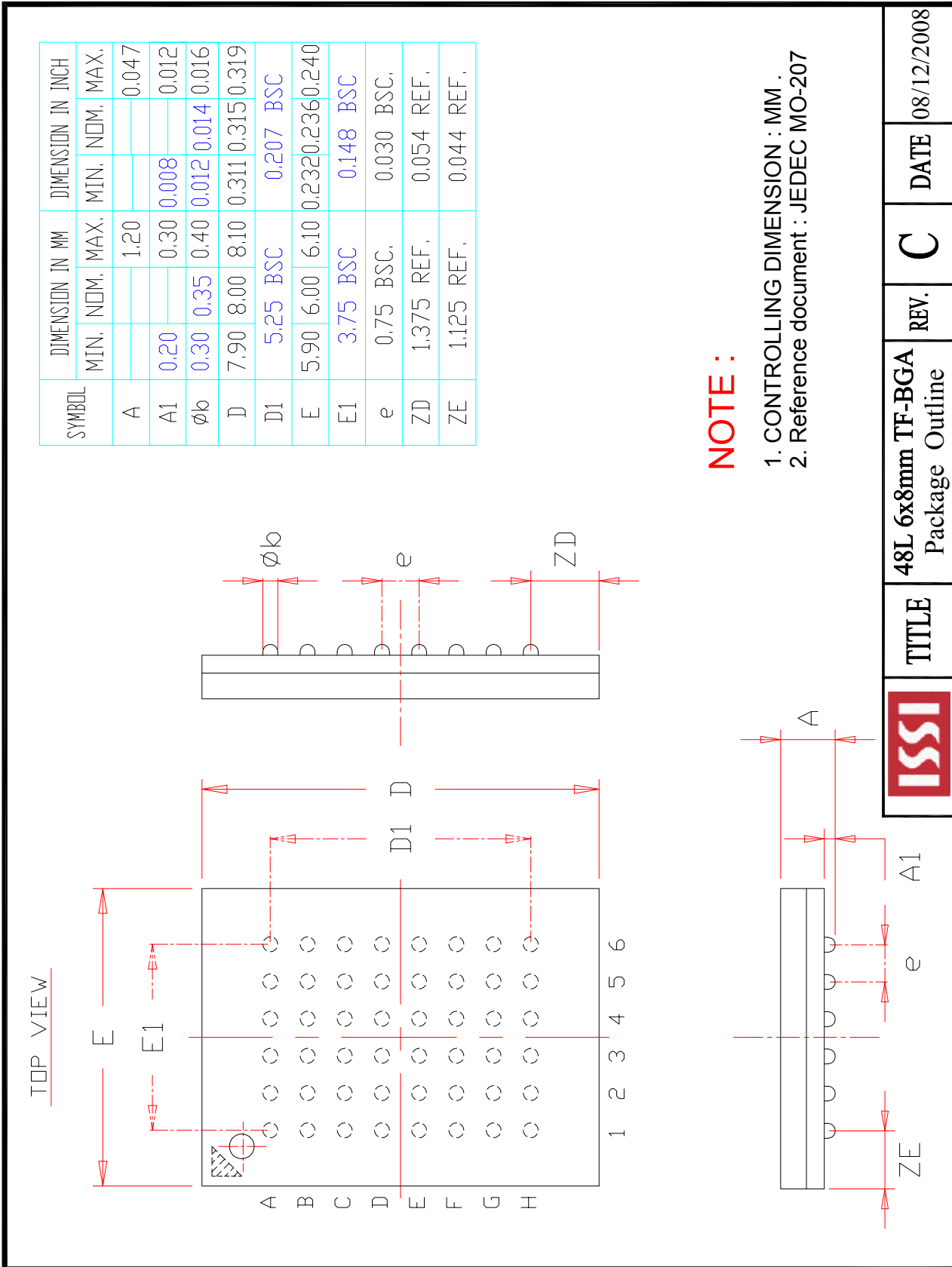

	TITLE	48L 6x8mm TF-BGA Package Outline	REV.	C	DATE	08/12/2008
--	-------	-------------------------------------	------	---	------	------------



Компания «ЭлектроПласт» предлагает заключение долгосрочных отношений при поставках импортных электронных компонентов на взаимовыгодных условиях!

Наши преимущества:

- Оперативные поставки широкого спектра электронных компонентов отечественного и импортного производства напрямую от производителей и с крупнейших мировых складов;
- Поставка более 17-ти миллионов наименований электронных компонентов;
- Поставка сложных, дефицитных, либо снятых с производства позиций;
- Оперативные сроки поставки под заказ (от 5 рабочих дней);
- Экспресс доставка в любую точку России;
- Техническая поддержка проекта, помощь в подборе аналогов, поставка прототипов;
- Система менеджмента качества сертифицирована по Международному стандарту ISO 9001;
- Лицензия ФСБ на осуществление работ с использованием сведений, составляющих государственную тайну;
- Поставка специализированных компонентов (Xilinx, Altera, Analog Devices, Intersil, Interpoint, Microsemi, Aeroflex, Peregrine, Syfer, Eurofarad, Texas Instrument, Miteq, Cobham, E2V, MA-COM, Hittite, Mini-Circuits, General Dynamics и др.);

Помимо этого, одним из направлений компании «ЭлектроПласт» является направление «Источники питания». Мы предлагаем Вам помощь Конструкторского отдела:

- Подбор оптимального решения, техническое обоснование при выборе компонента;
- Подбор аналогов;
- Консультации по применению компонента;
- Поставка образцов и прототипов;
- Техническая поддержка проекта;
- Защита от снятия компонента с производства.



#### Как с нами связаться

**Телефон:** 8 (812) 309 58 32 (многоканальный)

**Факс:** 8 (812) 320-02-42

**Электронная почта:** [org@eplast1.ru](mailto:org@eplast1.ru)

**Адрес:** 198099, г. Санкт-Петербург, ул. Калинина, дом 2, корпус 4, литера А.