

ARK-1388V

Intel® Core™ 2 Duo In-Vehicle Embedded IPC with Safe Start/Shutdown and Wireless Functions



Specifications

Features

- Intel® Core™ 2 Duo ULV U7500 1.06 GHz/Celeron® M ULV 423 1.06 GHz processor
- Startup and shutdown linked to car battery and ignition status
- Works with both 12 and 24-volt systems
- Optional built in WLAN/GPRS/EDGE/UMTS/HSDPA module
- Supports 50-channel GPS receiver
- Amplifier audio supports 6W stereo
- Supports VGA, LVDS dual independent display
- ISO-7637-2 Certified
- IP40 rating

Processor System	CPU	Intel Core 2 Duo ULV U7500	Intel Celeron M ULV 423
	Max. Speed	1.06 GHz	1.06 GHz
	Front Side Bus	533 MHz FSB	533 MHz FSB
	System Chipset	945GM + ICH7-M	
	BIOS	Award 4 MB Flash BIOS	
Memory	Technology	DDR2 533/667 MHz (945GM)	
	Max. Capacity	2 GB	
	Socket	1 x 200-pin SODIMM	
Graphics	Chipset	Integrated graphics built in to Intel 945GM, Intel 3.5 Generation Integrated Graphics Engine	
	Interfaces	CRT Interfaces 36-bit LVDS Interfaces	
Ethernet	LAN	10/100 Mbps Ethernet controller, Supports Wake on LAN	
Audio	Amplifier	Output 6 W Amplifier stereo	
	Interfaces	Spkr-out (L&R), Mic-in, RCA connector	
I/O Interfaces	Serial Ports	1 x RS-232 port, 3 x RS-232/422/485 ports selectable by jumper and RS-485 support auto flow control	
	USB Interfaces	4 x USB ports, USB 2.0 compliant	
Communication	GPS	Built-in u-blox LEA 5 GPS receiver, supports 50 channels	
	GPRS/EDGE/HSDPA	Wavecom Q2686, supports GSM/GPRS 850/900/1800/1900 MHz (optional);	
		Wavecom Q2687, supports GSM/GPRS/EDGE (optional); Siemens HC25, supports UMTS/HSDPA (optional)	
Other	Digital I/O	6-bit, 4 x digital input with isolation and 2 x digital output with relay	
	Thermal Alarm	Blue LED Lighting	
	Watchdog Timer	255 level timer interval, setup by software	
Expansion	Mini PCI	1 Slot Mini PCI	
Storage	HDD	-	
	SSD	Supports CompactFlash socket for type I/II CompactFlash disk	
Software Support	Microsoft Windows	Vista, XP Professional, XP Embedded, 2000, CE .NET 6.0	
Power Requirements	Power Type	AT/ATX	
	Power Input Voltage	9 V _{DC} ~ 32 V _{DC} , minimum support: 6 V _{DC} , cold crank of ISO-7637-2	
	Minimum Power Input	9 V @ 5.11 A --- 35 V @ 1.32 A	
	Power Adapter	AC to DC, DC19 V/3.42 A, 65 W	
Power Consumption	Typical	15.72 W (Intel Core 2 Duo ULV U7500 1.06 GHz)	
	Max	46 W (Intel Core 2 Duo ULV U7500 1.06 GHz)	
SW Power Monitor	Power Ignition On Control	Power on delay, default 10 secs	
	Power Ignition Off Control	Power off delay, default 60 secs	
		Power hard off delay, default 180 secs	
Mechanical	Construction	Aluminum housing	
	Mounting	DIN-rail mounting; Desk/wall-mounting; VESA mounting	
	Dimensions (W x H x D)	189 x 63.76 x 130.6mm (7.44" x 2.51" x 5.14")	
	Weight	1.9 kg (4.18 lb)	
Environment	Operating Temperature	Intel Celeron M ULV423 1.06 GHz: -20 ~ 60° C (-4 ~ 140° F) Intel Core 2 Duo U7500 1.06 GHz: -20 ~ 55° C (-4 ~ 131° F)	
	Storage Temperature	-40 ~ 85° C (-40 ~ 185° F)	
	Relative Humidity	95% @ 40° C (non-condensing)	
	Vibration During Operation	With CompactFlash disk: 5 Grms, IEC 60068-2-64, random, 5 ~ 500 Hz, 1 Oct./min, 1hr/axis/MIL-STD 514.5C-3	
	Shock During Operation	With CompactFlash disk: 50 Grms, IEC 60068-2-27, half sine, 11 ms duration. /MIL-STD 516.5	
	EMC	CE/FCC Class A, CCC, BSMI	
	Safety Certifications	UL, CCC, BSMI	
	In-Vehicle Certification	ISO-7637-2, E-Mark E13	

Dimensions

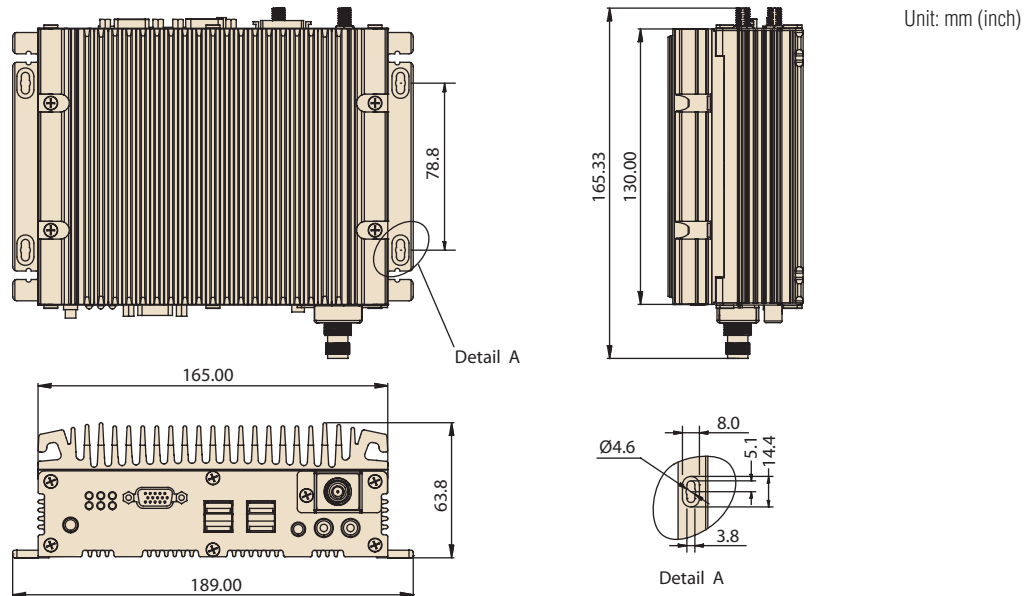

Front Panel External I/O Mechanical Layout/Drawing

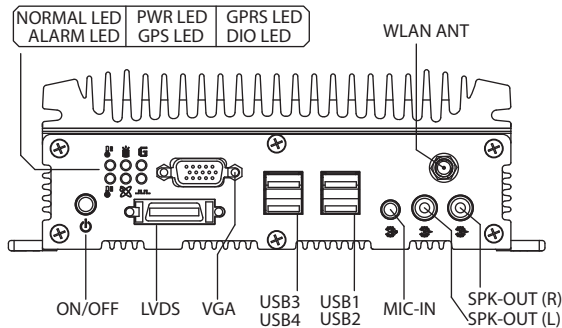

Rear Panel External I/O Mechanical Layout/Drawing

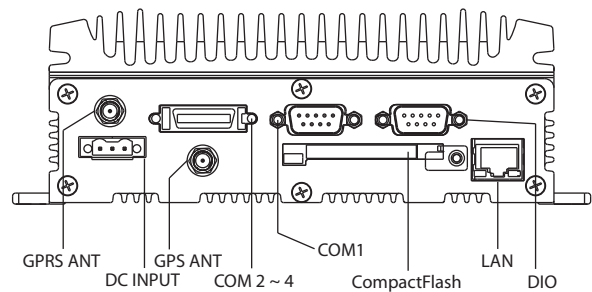

Packing List

Part Number	Description
-	1 x ARK-1388 unit
-	1 x Driver/Utility CD/Manual
-	1 x Traditional Chinese user manual for CCC
-	1 x China RoHS
1700012555	1 x 3-Pole Phoenix to DC jack cable
1750001782	1 x Antenna GPS Active 5v 38x40 with 5M SMA GA31B
1700012535	1 x One connector to three RS-232/422/485 ports Cable
1700012536	1 x DB9 to 10-pole Phoenix DIO cable

Optional Items

Part Number	Description
1757003659	AC-to-DC adaptor, DC19V V/3.42A 65W, with Phoenix power plug, 0-40C for Home and Office Use
1700001947	Power Cable 2-pin 180 cm, USA type
1700001948	Power Cable 2-pin 180 cm, Europe Type
1700001949	Power Cable 2-pin 180 cm, UK Type
9666K10000E	DIN-rail Mounting Kit
1960025333N00N	VESA Mounting plate
1750003222	802.11b/g 5dBi Dipole Antenna
968EMW0004	802.11a/b/g Mini-PCI card
AMO-EDGE	AMO-Q2687 GSM/GPRS/EDGE module with antenna
AMO-HSDPA	AMO-HC25 UMTS/HSDPA module with antenna

Ordering Information

Part Number	Description
ARK-1388V-S0A1E	Intel Celeron M ULV423 1.06 GHz Ultra-compact embedded box IPC
ARK-1388V-S1A1E	Intel Core 2 Duo U7500 1.06 GHz Ultra-compact embedded box IPC

Embedded OS

Part Number	Description
2070009541	WES2009 ARK-1388 V4.01-2 ENG
2070009542	WES2009 ARK-1388 V4.01-2 ENG/CHS/CHT/JPN



Компания «ЭлектроПласт» предлагает заключение долгосрочных отношений при поставках импортных электронных компонентов на взаимовыгодных условиях!

Наши преимущества:

- Оперативные поставки широкого спектра электронных компонентов отечественного и импортного производства напрямую от производителей и с крупнейших мировых складов;
- Поставка более 17-ти миллионов наименований электронных компонентов;
- Поставка сложных, дефицитных, либо снятых с производства позиций;
- Оперативные сроки поставки под заказ (от 5 рабочих дней);
- Экспресс доставка в любую точку России;
- Техническая поддержка проекта, помощь в подборе аналогов, поставка прототипов;
- Система менеджмента качества сертифицирована по Международному стандарту ISO 9001;
- Лицензия ФСБ на осуществление работ с использованием сведений, составляющих государственную тайну;
- Поставка специализированных компонентов (Xilinx, Altera, Analog Devices, Intersil, Interpoint, Microsemi, Aeroflex, Peregrine, Syfer, Eurofarad, Texas Instrument, Miteq, Cobham, E2V, MA-COM, Hittite, Mini-Circuits, General Dynamics и др.);

Помимо этого, одним из направлений компании «ЭлектроПласт» является направление «Источники питания». Мы предлагаем Вам помощь Конструкторского отдела:

- Подбор оптимального решения, техническое обоснование при выборе компонента;
- Подбор аналогов;
- Консультации по применению компонента;
- Поставка образцов и прототипов;
- Техническая поддержка проекта;
- Защита от снятия компонента с производства.



Как с нами связаться

Телефон: 8 (812) 309 58 32 (многоканальный)

Факс: 8 (812) 320-02-42

Электронная почта: org@eplast1.ru

Адрес: 198099, г. Санкт-Петербург, ул. Калинина, дом 2, корпус 4, литера А.