

## KILOVAC LEV100 Series 900 Vdc Contactor With 1 Form X Contacts Rated 100A Continuous

### Product Facts

- Hermetically sealed — intrinsically safe. Operates in explosive/harsh environments without oxidation or contamination of contacts, including long periods of non-operation
- 8kV isolation between open contacts permits use for high voltage isolation and carry
- 12, 24 and 48 Vdc coils
- Designed and built in accordance to AIAG QS9000
- Not position sensitive, can be mounted in any orientation
- Solid copper contacts
- UL Recognized for the U.S. and Canada (File E208033) All contact ratings & coil versions may not be UL Recognized
- RoHS versions available

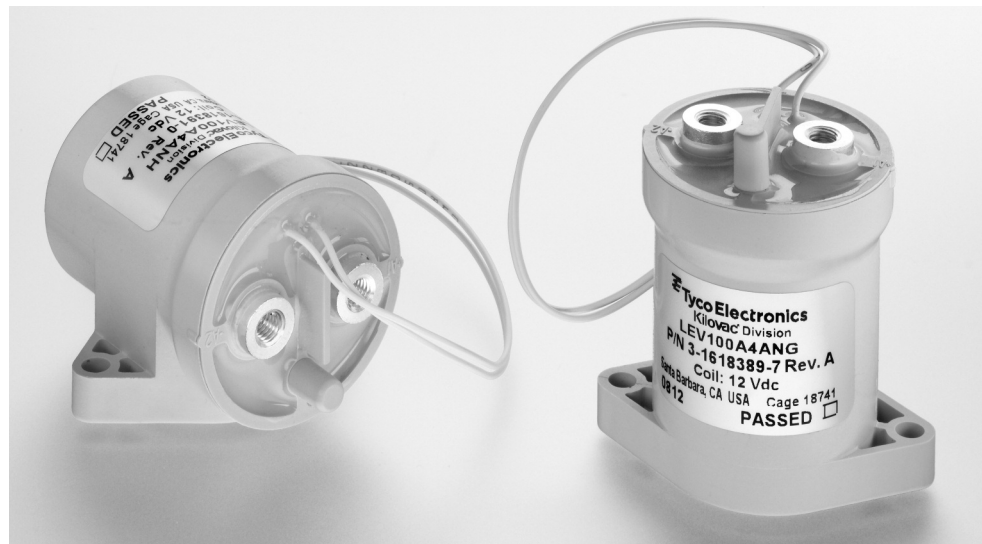

### Description

Lowest cost, 900 Vdc 100 amp, hermetically sealed DC contactor in the industry

Compact package available in side- or bottom-mount configurations, not position sensitive

### Applications

Power/motor control circuit isolation, circuit protection and safety in industrial machinery

Automotive battery switching and backup

### Mechanical

Compact epoxy-sealed resin enclosure occupies only about 4 in<sup>3</sup> (65.5 cm<sup>3</sup>)

Robust integral mounting plate on either bottom or side of enclosure accepts two M4 screws

Inert gas filled contact chamber

Flying leads for coil connections

Load terminals threaded for M5 bolts (not included)

### Performance Data

#### Physical Data

**Contact Arrangement, Main Contacts** — SPST-NO-DM (1 Form X)

**Dimensions** — See drawings on next page

**Weight** — 6.7 oz (190g)

#### Contact Data

**Contact Arrangement, Main Contacts** — SPST-NO-DM (1 Form X)

**Voltage Rating, Main Contacts Switching (Max)** — 900VDC

**Current Rating, Main Contacts Switching** —

Continuous<sup>1</sup> — 100A  
Short Term, 3 Minutes<sup>2</sup> — 200A

**Hot Switching Performance (Polarity Sensitive)** —

50A make/break @ +400Vdc — 50,000 cycles

100A make/break @ +400Vdc — 6,000 cycles

100A make/break @ -400Vdc — 1,000 cycles

200A make/break @ +400Vdc — 500 cycles

1,000A break only @ +400Vdc — 250 cycles

600A make only — 25 cycles

**Maximum Short Circuit Current (1/2 cycle, 60 Hz)** — 1,250A (through closed contacts)

**Dielectric Withstand Voltage<sup>3</sup> —**

Between Open Contacts —

5,600Vrms/8,000Vdc

Contacts to Coil —

2,000Vrms/4,000Vdc

#### Insulation Resistance, Terminal to Terminal / Terminals to Coil —

When New — 100 megohms, min. @ 500Vdc

At End of Life — 50 megohms, min. @ 500Vdc

**Mechanical Life** — 1 million cycles

#### Operate & Release Time

**Operate Time Max.** — 25ms

**Operate Bounce Max.** — 5ms

**Release Time** — 10ms

#### Environmental Data

**Shock, 11ms 1/2 sine (operating)** — 20G peak

**Sine Vibration, 20G peak** — 55-2,000 Hz.

**Operating Temperature Range** — -40°C to +85°C

**Noise Emission (at 100 mm distance)** — 70dB(a)

#### Notes

1 8.4 mm<sup>2</sup> conductor. Current rating depends upon conductor size. Keep terminals below 175°C max continuous.

2 3 minutes at +40°C ambient with 8.4 mm<sup>2</sup> (#8 AWG) conductor.

3 2,000Vrms minimum under all conditions, until end of life.

For factory-direct application assistance, dial 800-253-4560, ext. 2055, or 805-220-2055.

**KILOVAC LEV100 Series 900 Vdc Contactor** (Continued)

Coil Operating Voltage (Valid Over Temperature Range)			
Nominal Voltage	12Vdc	24Vdc	48Vdc
Maximum Voltage	16Vdc	28Vdc	52Vdc
Pick Up Voltage (20°C)	8Vdc	16Vdc	33Vdc
Drop Out Voltage (20°C)	≤1.2Vdc	≤2.4Vdc	≤4.8Vdc
Coil Current (Nominal at 20°C, 12vdc)	461mA	250mA	122mA
Coil Power Nominal @ Vnom, +20°C	5.5W	6.0W	6.0W
Pickup (Close) Voltage Max. @85°C	9.6Vdc	19.2Vdc	38.4Vdc
Coil Resistance Nominal @ +20°C ± 5% (ohms)	26	96	392

**Life Cycles vs Resistive Load up to 900Vdc**

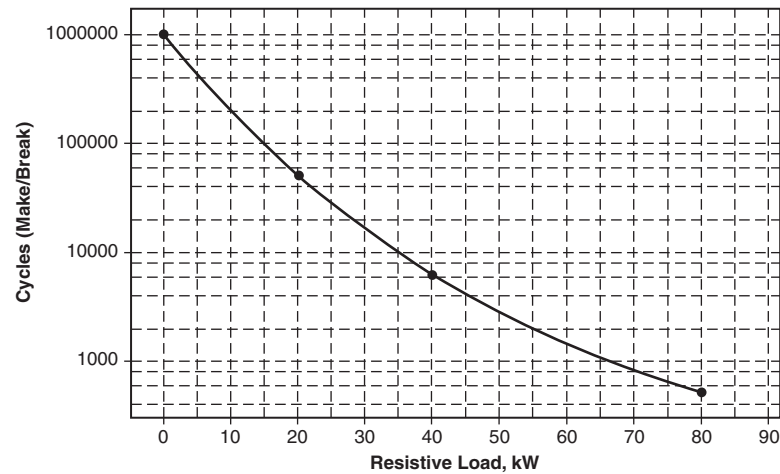

**Ordering Information**

Typical Part Number ► **LEV100 A 4 A N G**

- Series:** \_\_\_\_\_  
LEV100 = 100A Contactor
- Contact Arrangement:** \_\_\_\_\_  
A = 1 Form X (SPST-NO-DM)
- Coil Voltage:** \_\_\_\_\_  
4 = 12VDC  
5 = 24VDC  
6 = 48VDC
- Coil Wire Length:** \_\_\_\_\_  
A = 15 inches [.4M]
- Coil Termination:** \_\_\_\_\_  
N = None – Stripped Wires
- Mounting and Power Terminals:** \_\_\_\_\_  
G = Bottom Mount (2 x #8); M5 x 10  
H = Side Mount (2 x #8); M5 x 10

For factory-direct application assistance, dial 800-253-4560, ext. 2055, or 805-220-2055.

**KILOVAC LEV100 Series 900 Vdc Contactor** (Continued)

**Bottom Mount**

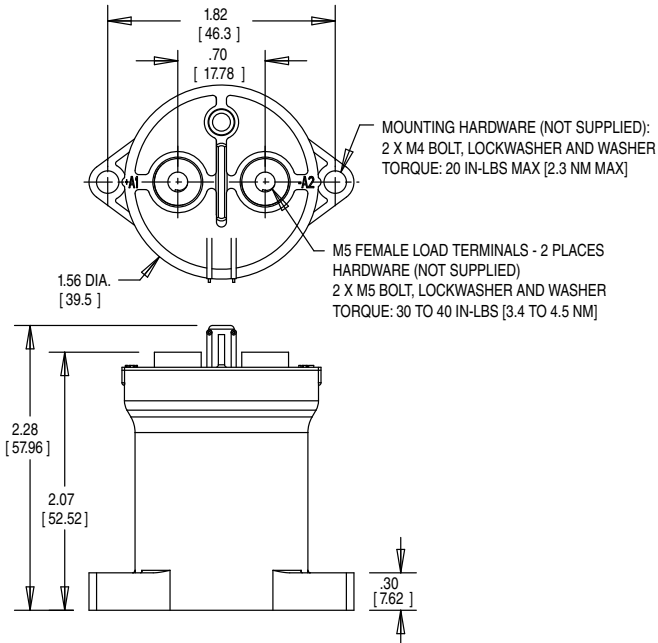

**Side Mount**

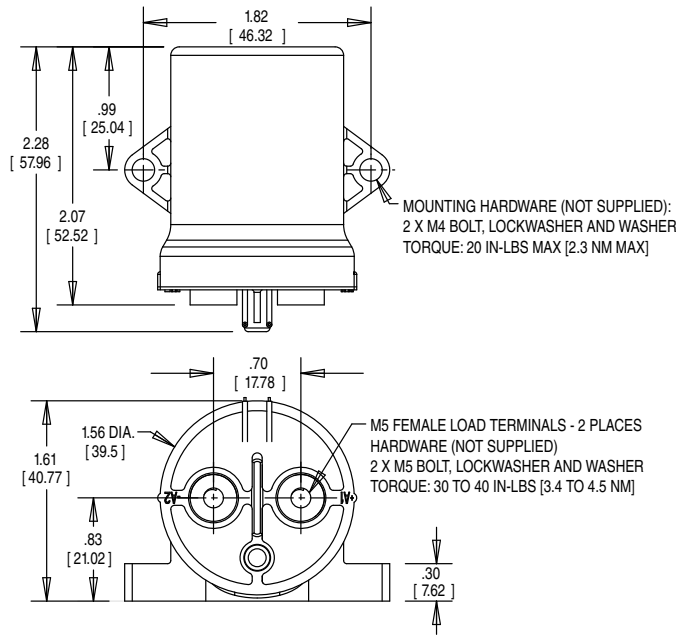

**Product Offering**

Bottom Mount Models			
3-1618389-7	LEV100A4ANG	12Vdc coil	15" [.4m] leads
9-1618389-8	LEV100A5ANG	24Vdc coil	15" [.4m] leads
3-1618391-7	LEV100A6ANG	48Vdc coil	15" [.4m] leads
Side Mount Models			
4-1618391-0	LEV100A4ANH	12Vdc coil	15" [.4m] leads
4-1618391-1	LEV100A5ANH	24Vdc coil	15" [.4m] leads
4-1618391-2	LEV100A6ANH	48Vdc coil	15" [.4m] leads

For factory-direct application assistance, dial 800-253-4560, ext. 2055, or 805-220-2055.



Компания «ЭлектроПласт» предлагает заключение долгосрочных отношений при поставках импортных электронных компонентов на взаимовыгодных условиях!

Наши преимущества:

- Оперативные поставки широкого спектра электронных компонентов отечественного и импортного производства напрямую от производителей и с крупнейших мировых складов;
- Поставка более 17-ти миллионов наименований электронных компонентов;
- Поставка сложных, дефицитных, либо снятых с производства позиций;
- Оперативные сроки поставки под заказ (от 5 рабочих дней);
- Экспресс доставка в любую точку России;
- Техническая поддержка проекта, помощь в подборе аналогов, поставка прототипов;
- Система менеджмента качества сертифицирована по Международному стандарту ISO 9001;
- Лицензия ФСБ на осуществление работ с использованием сведений, составляющих государственную тайну;
- Поставка специализированных компонентов (Xilinx, Altera, Analog Devices, Intersil, Interpoint, Microsemi, Aeroflex, Peregrine, Syfer, Eurofarad, Texas Instrument, Miteq, Cobham, E2V, MA-COM, Hittite, Mini-Circuits, General Dynamics и др.);

Помимо этого, одним из направлений компании «ЭлектроПласт» является направление «Источники питания». Мы предлагаем Вам помощь Конструкторского отдела:

- Подбор оптимального решения, техническое обоснование при выборе компонента;
- Подбор аналогов;
- Консультации по применению компонента;
- Поставка образцов и прототипов;
- Техническая поддержка проекта;
- Защита от снятия компонента с производства.



#### Как с нами связаться

**Телефон:** 8 (812) 309 58 32 (многоканальный)

**Факс:** 8 (812) 320-02-42

**Электронная почта:** [org@eplast1.ru](mailto:org@eplast1.ru)

**Адрес:** 198099, г. Санкт-Петербург, ул. Калинина, дом 2, корпус 4, литера А.