

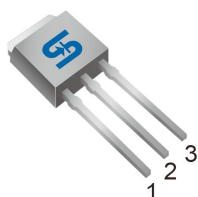

TO-251
(IPAK)

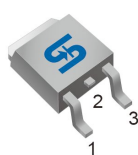

TO-252
(DPAK)



Pin Definition:

1. Base
2. Collector
3. Emitter

PRODUCT SUMMARY

BV_{CEO}	400V
BV_{CBO}	700V
I_C	3A
$V_{CE(SAT)}$	0.17V @ $I_C=1A, I_B=0.25A$

Features

- Build-in Free-wheeling Diode Makes Efficient Anti-saturation Operation
- No Need to Interest an h_{FE} Value Because of Low Variable Storage-time Spread Even Though Corner Spirit Product.
- Low Base Drive Requirement
- Suitable for Half Bridge Light Ballast Application

Structure

- Silicon Triple Diffused Type
- NPN Silicon Transistor
- Integrated Anti-parallel Collector-Emitter Diode

Block Diagram

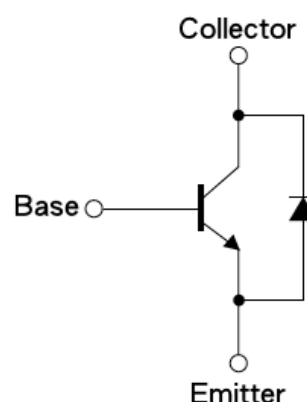

Ordering Information

Part No.	Package	Packing
TSC5303DCP ROG	TO-252	2.5kpcs / 13" Reel
TSC5303DCH C5G	TO-251	75pcs / Tube

Note: "G" denotes Halogen Free Products

Absolute Maximum Ratings ($T_a = 25^{\circ}C$ unless otherwise noted)

Parameter	Symbol	Limit	Unit
Collector-Base Voltage	V_{CBO}	700	V
Collector-Emitter Voltage @ $V_{BE}=0V$	V_{CES}	700	V
Collector-Emitter Voltage	V_{CEO}	400	V
Emitter-Base Voltage	V_{EBO}	9	V
Collector Current	I_C	3	A
Collector Peak Current ($t_p < 5ms$)	I_{CM}	6	A
Base Current	I_B	1.5	A
Base Peak Current ($t_p < 5ms$)	I_{BM}	3	A
Power Total Dissipation @ $T_C=25^{\circ}C$	P_{DTOT}	30	W
Maximum Operating Junction Temperature	T_J	+150	$^{\circ}C$
Storage Temperature Range	T_{STG}	-55 to +150	$^{\circ}C$

Thermal Performance

Parameter	Symbol	Limit	Unit
Thermal Resistance - Junction to Case	$R\theta_{JC}$	4.15	$^{\circ}\text{C}/\text{W}$
Thermal Resistance - Junction to Ambient	$R\theta_{JA}$	75	$^{\circ}\text{C}/\text{W}$

Electrical Specifications (Ta = 25 $^{\circ}\text{C}$ unless otherwise noted)

Parameter	Conditions	Symbol	Min	Typ	Max	Unit
Static						
Collector-Base Voltage	$I_C = 1\text{mA}, I_B = 0$	BV_{CBO}	700	--	--	V
Collector-Emitter Breakdown Voltage	$I_C = 10\text{mA}, I_E = 0$	BV_{CEO}	400	--	--	V
Emitter-Base Breakdown Voltage	$I_E = 1\text{mA}, I_C = 0$	BV_{EBO}	9	--	--	V
Collector Cutoff Current	$V_{CB} = 700\text{V}, I_E = 0$	I_{CBO}	--	--	10	μA
Collector Cutoff Current	$V_{CE} = 400\text{V}, I_B = 0$	I_{CEO}	--	--	10	μA
Emitter Cutoff Current	$V_{EB} = 7\text{V}, I_C = 0$	I_{EBO}	--	--	10	μA
Collector-Emitter Saturation Voltage	$I_C = 0.4\text{A}, I_B = 0.1\text{A}$	$V_{CE(SAT)1}$	--	0.10	0.7	V
	$I_C = 1\text{A}, I_B = 0.25\text{A}$	$V_{CE(SAT)2}$	--	0.17	1	
	$I_C = 2\text{A}, I_B = 0.5\text{A}$	$V_{CE(SAT)3}$	--	0.55	--	
Base-Emitter Saturation Voltage	$I_C = 1\text{A}, I_B = 0.25\text{A}$	$V_{BE(SAT)1}$	--	--	1.1	V
	$I_C = 2\text{A}, I_B = 0.5\text{A}$	$V_{BE(SAT)2}$	--	--	1.2	
DC Current Gain	$V_{CE} = 5\text{V}, I_C = 10\text{mA}$	h_{FE}	10	--	--	
	$V_{CE} = 5\text{V}, I_C = 1\text{A}$		15	--	30	
	$V_{CE} = 5\text{V}, I_C = 2\text{A}$		5	--	--	
Forward Voltage Drop	$I_F = 2\text{A}$	Vf	--	--	2	V
Turn On Time	$V_{CC} = 250\text{V}, I_C = 1\text{A},$	t_{ON}	--	0.2	0.6	μs
Storage Time	$I_{B1} = I_{B2} = 0.2\text{A}, t_p = 25\mu\text{s}$	t_{STG}	--	2.7	4.5	μs
Fall Time	Duty Cycle < 1%	t_f	--	0.16	0.3	μs

Note: Pulsed duration = 380 μs , duty cycle $\leq 2\%$

Electrical Characteristics Curve (Ta = 25°C, unless otherwise noted)

Figure 1. Static Characteristics

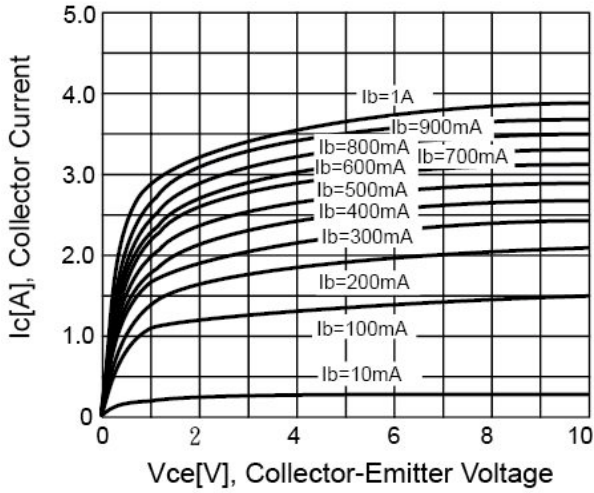

Figure 2. DC Current Gain

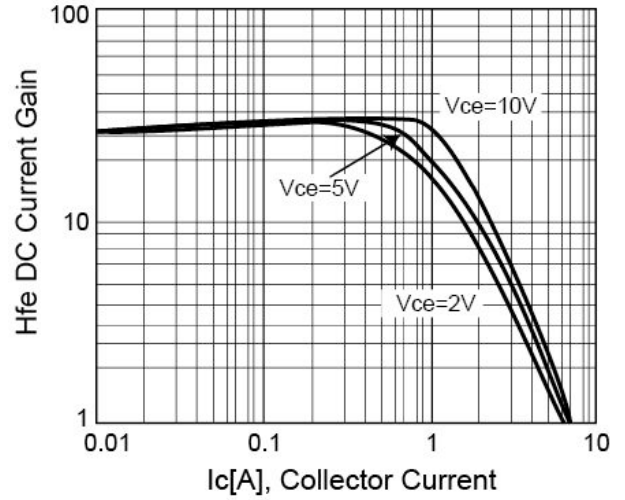

Figure 3. Vce(sat) v.s. Vbe(sat)

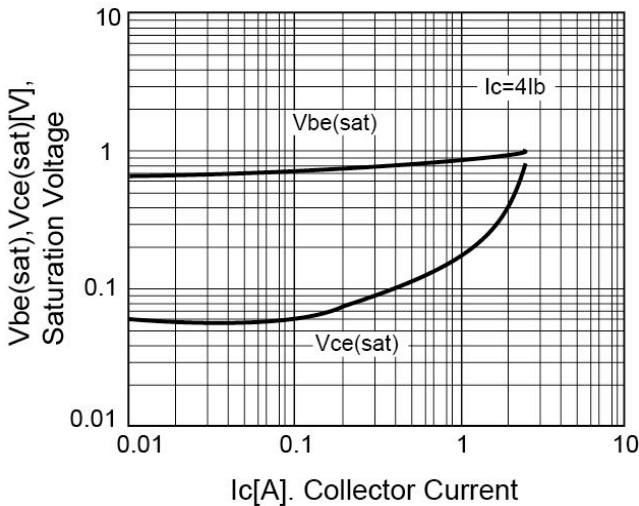

Figure 4. Power Derating

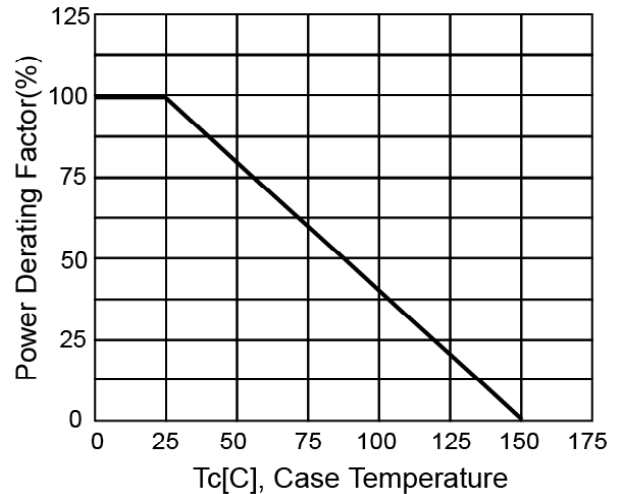

Figure 5. Reverse Bias SOA

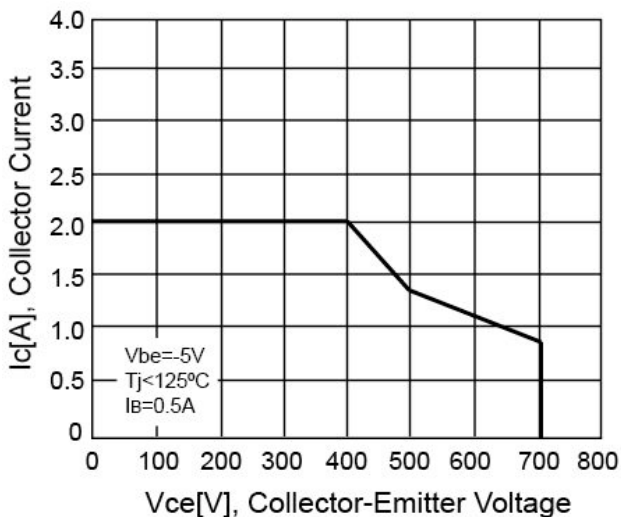
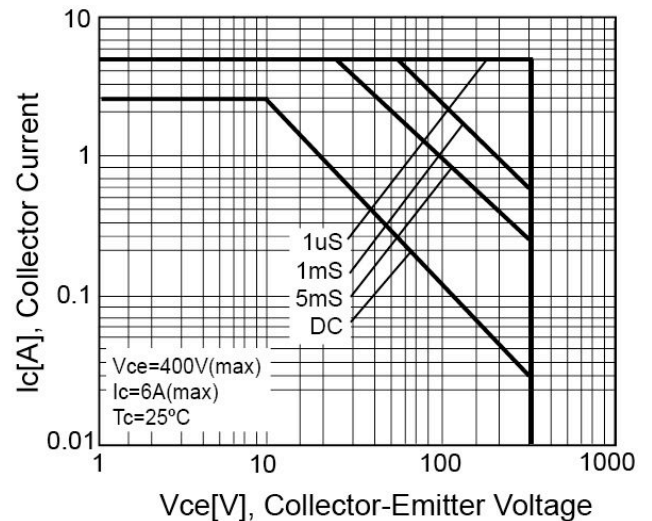
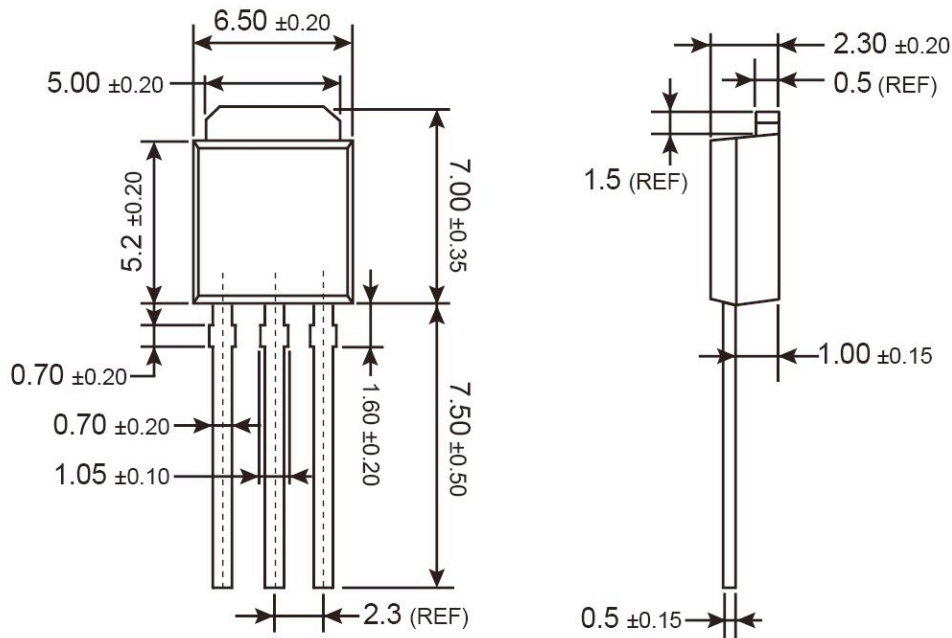

Figure 6. Safety Operating Area



TO-251 Mechanical Drawing



Unit: Millimeters

Marking Diagram

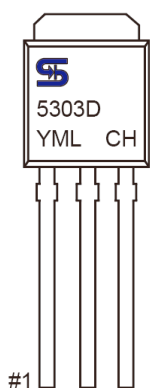

- Y** = Year Code
- M** = Month Code for Halogen Free Product
(**O**=Jan, **P**=Feb, **Q**=Mar, **R**=Apr, **S**=May, **T**=Jun, **U**=Jul, **V**=Aug, **W**=Sep, **X**=Oct, **Y**=Nov, **Z**=Dec)
- L** = Lot Code

TO-252 Mechanical Drawing

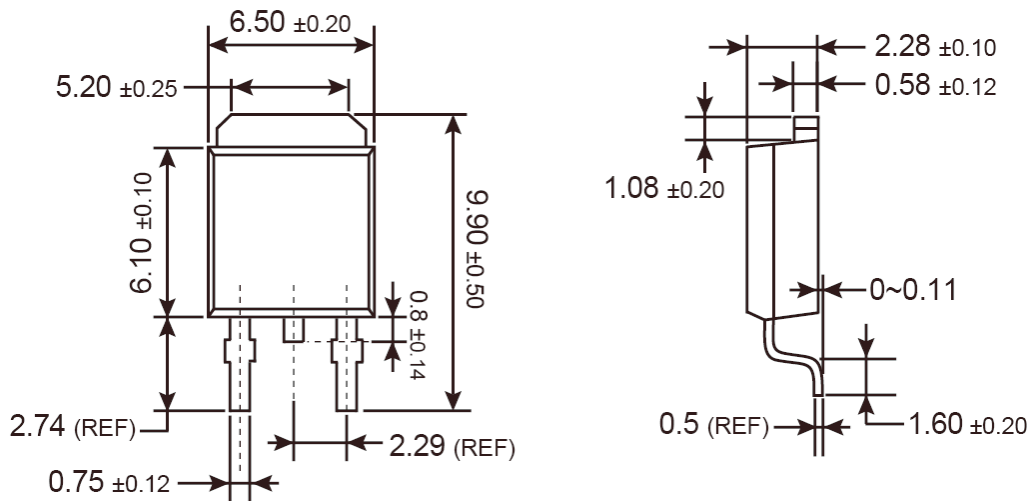

Unit: Millimeters

Marking Diagram

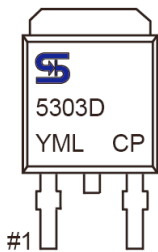

- Y** = Year Code
- M** = Month Code for Halogen Free Product
(**O**=Jan, **P**=Feb, **Q**=Mar, **R**=Apr, **S**=May, **T**=Jun, **U**=Jul, **V**=Aug, **W**=Sep, **X**=Oct, **Y**=Nov, **Z**=Dec)
- L** = Lot Code

Notice

Specifications of the products displayed herein are subject to change without notice. TSC or anyone on its behalf, assumes no responsibility or liability for any errors or inaccuracies.

Information contained herein is intended to provide a product description only. No license, express or implied, to any intellectual property rights is granted by this document. Except as provided in TSC's terms and conditions of sale for such products, TSC assumes no liability whatsoever, and disclaims any express or implied warranty, relating to sale and/or use of TSC products including liability or warranties relating to fitness for a particular purpose, merchantability, or infringement of any patent, copyright, or other intellectual property right.

The products shown herein are not designed for use in medical, life-saving, or life-sustaining applications. Customers using or selling these products for use in such applications do so at their own risk and agree to fully indemnify TSC for any damages resulting from such improper use or sale.



Компания «ЭлектроПласт» предлагает заключение долгосрочных отношений при поставках импортных электронных компонентов на взаимовыгодных условиях!

Наши преимущества:

- Оперативные поставки широкого спектра электронных компонентов отечественного и импортного производства напрямую от производителей и с крупнейших мировых складов;
- Поставка более 17-ти миллионов наименований электронных компонентов;
- Поставка сложных, дефицитных, либо снятых с производства позиций;
- Оперативные сроки поставки под заказ (от 5 рабочих дней);
- Экспресс доставка в любую точку России;
- Техническая поддержка проекта, помощь в подборе аналогов, поставка прототипов;
- Система менеджмента качества сертифицирована по Международному стандарту ISO 9001;
- Лицензия ФСБ на осуществление работ с использованием сведений, составляющих государственную тайну;
- Поставка специализированных компонентов (Xilinx, Altera, Analog Devices, Intersil, Interpoint, Microsemi, Aeroflex, Peregrine, Syfer, Eurofarad, Texas Instrument, Miteq, Cobham, E2V, MA-COM, Hittite, Mini-Circuits, General Dynamics и др.);

Помимо этого, одним из направлений компании «ЭлектроПласт» является направление «Источники питания». Мы предлагаем Вам помощь Конструкторского отдела:

- Подбор оптимального решения, техническое обоснование при выборе компонента;
- Подбор аналогов;
- Консультации по применению компонента;
- Поставка образцов и прототипов;
- Техническая поддержка проекта;
- Защита от снятия компонента с производства.



Как с нами связаться

Телефон: 8 (812) 309 58 32 (многоканальный)

Факс: 8 (812) 320-02-42

Электронная почта: org@eplast1.ru

Адрес: 198099, г. Санкт-Петербург, ул. Калинина, дом 2, корпус 4, литера А.